

YES 45 TU Front Set Storefront System

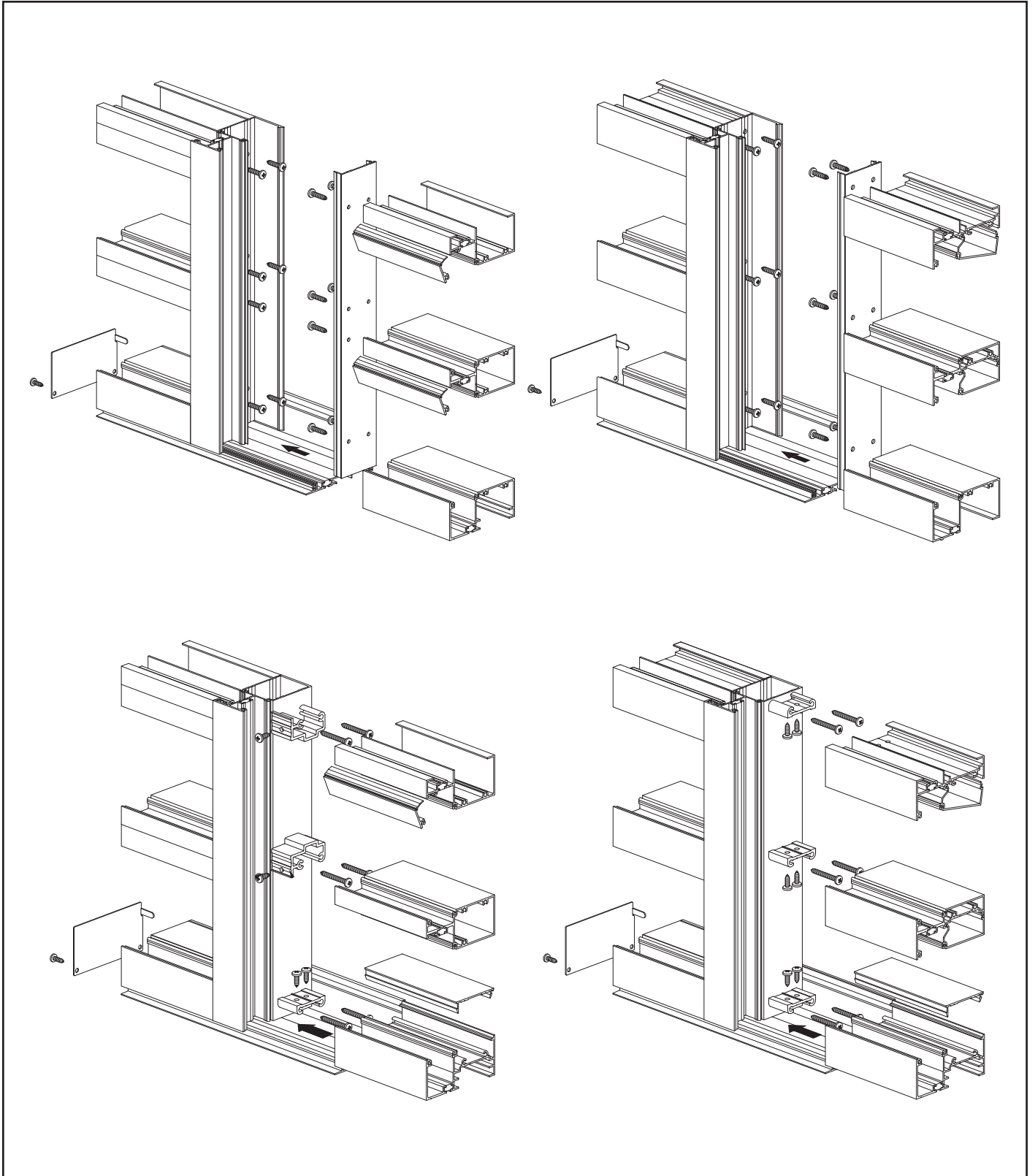

Installation Manual

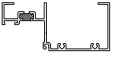

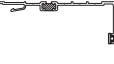



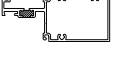

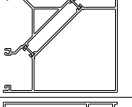





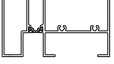







TABLE OF CONTENTS

Installation Notes	Page ii
PARTS DESCRIPTION	
YES 45 TU Front Set Framing Members.....	Pages 1 & 2
YES 45 TU Front Set Door Framing Members.....	Page 3
YES 45 TU Front Set Accessories & Fasteners.....	Pages 4 & 5
FRAME FABRICATION	
Determine Frame Size	Pages 6 & 7
Fabricate Two Piece Mullions for Screw Spline Assembly.....	Page 8
Fabricate Tubular Mullions for Shear Block Assembly	Page 9
Fabricate Fillers for Corner Mullions for Screw Spline Assembly.....	Page 10
Fabricate Fillers for Corner Mullions for Shear Block Assembly	Page 11
Fabricate Heads & Horizontals	Pages 12 & 13
Fabricate Sill Flashing.....	Pages 14 to 15
Fabricate Head Receptor.....	Page 16
Fabricate Sill Members	Page 17
Fabricate Glass Stops & Glazing Adaptors	Page 18
FRAME ASSEMBLY	
Assemble Frames for Screw Spline Assembly	Pages 19 & 20
Assemble Frames For Shear Block Assembly	Pages 21 & 22
Install Foam Plugs at Head.....	Page 23
Attach Corner Assemblies	Page 24
Install Expansion Mullions Where Required	Page 25
FRAME INSTALLATION	
Install Sill Flashing End Dams	Page 26
Install Sill Flashing	Page 27
Install Sill Flashing Splice Sleeve	Pages 27 & 28
Sill Preparation.....	Page 28
Attach Head Receptor End Caps.....	Page 29
Install Head Receptor	Page 30
Install Sill Flashing at Corners	Page 31
Install Frames	Pages 32 to 38
Apply Perimeter Sealant	Pages 39 & 40
Install Water Deflectors.....	Page 41
Install Horizontal Flush Fillers (Shear Block Assembly Only).....	Page 42
Apply Internal Sealant.....	Page 43
Install Glazing Adaptors.....	Page 44
GLAZING	
Install Interior Glazing Gaskets.....	Page 45
Install Glass	Page 46
Install Anti-Walk Blocks.....	Page 47
Install Exterior Glass Stops & Gaskets.....	Page 48













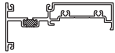
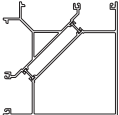

Installation Notes

1. Do not drop, roll or drag boxes of aluminum framing. Move and stack boxes with proper support to prevent distortion. If fork lifts are used be especially careful about striking the boxes when lifting or moving.
2. Store in a dry, out of the way area. If rain exposure, condensation or any water contact is likely, then all packaging material should be removed. Wet packaging materials will discolor and may stain aluminum finishes and paints.
3. All materials should be checked for quality and quantity upon receipt, YKK AP must be notified immediately of any discrepancies in shipment. Check to make sure that you have the required shims, sealants, supplies and tools necessary for the installation.
4. Carefully check the openings and surrounding conditions that will receive your material. Remember, if the construction is not per the construction documents, it is your responsibility to notify the general contractor in writing. Any discrepancies must be brought to the general contractor's attention before you proceed with the installation.
5. Gather your shop drawings, materials, packing list, and this installation manual. Carefully review parts location, the sequence it goes therein, when you glaze it and how you seal it. Installation instructions are of a general nature and may not cover every condition you will encounter. The shop drawings and/or installation manuals were prepared specifically for the product.
6. Any material substitutions must be of equal or greater quality.
7. Make certain that material samples have been sent for compatibility testing for all manufacturer's sealants involved. Make certain sealants have been installed in strict accordance with the manufacturer's recommendations and specifications.
8. Remember to isolate, in an approved manner, all aluminum from uncured masonry or other incompatible materials.
9. System-to-structure fasteners are not supplied by YKK AP. Fasteners called out on shop drawings are to indicate minimum sizes for design loading.
10. Entrances are to be installed plumb, square, level, and true.
11. If any questions arise concerning YKK AP products or their installation, contact YKK AP for clarification before proceeding.
12. YKK AP storefront and/or curtain wall framing is typically completed before drywall, flooring and other products which may still be in process. Take the extra time to wrap and protect the work produced.
13. Cutting tolerances are plus zero (0"), minus one thirty second (-1/32") unless otherwise noted.
14. Check our website, www.ykkap.com, for the latest installation manual update prior to commencing work.

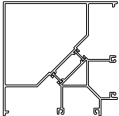
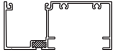
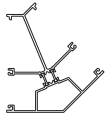
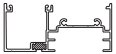
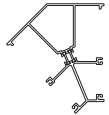
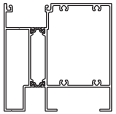
FRAMING MEMBERS (2" x 4-1/2") FOR OUTSIDE GLAZING



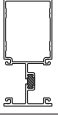
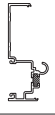
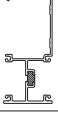
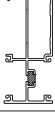







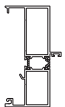











	Head	BE9-2514		Flush Filler	E9-2512
	Head Receptor	BE9-2562		Expansion Mullion (Male)	BE9-2526
	Head Receptor Stop Use with BE9-2562	E9-1033		Tubular Expansion Mullion (Male)	BY7-8474
	Horizontal Screw Spline Assembly	BE9-2515		Expansion Mullion (Female)	BE9-2525
	Horizontal Shear Block Assembly	BE9-2517		90° Outside Corner Mullion	BE9-2507
	Glass Stop Use with BE9-2514 BE9-2515 & BE9-2517	E9-2519		90° Inside Corner Mullion	BE9-2506
	Sill/Jamb Screw Spline Assembly	BE9-2513		135° Outside Corner Mullion	BE9-2504
	Sill Shear Block Assembly	BE9-2518		135° Inside Corner Mullion	BE9-2505
	4-1/2" Sill Screw Spline Assembly	BY7-9762		0°-12.5° Hinged Inside Corner Mullion (Male)	BE9-2524
	Thermal Sill Flashing	BE9-2578		0°-15° Hinged Outside Corner Mullion (Male)	BE9-2527
	Snap-in Filler Use with E9-0490 at Jamb Conditions	E9-0491		Hinged Corner Mullion (Female) Use with BE9-2524 or BE9-2527	BE9-2528
	One Piece Mullion Shear Block Assembly	BE9-2516		Two Piece Tubular Mullion Screw Spline Assembly	BY7-8473
	Two Piece Mullion Screw Spline Assembly	BE9-2511			

FRAMING MEMBERS (2" x 4-1/2") FOR INSIDE GLAZING

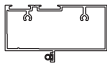

	Head	BE9-2521		Expansion Mullion (Male)	BE9-2526
	Head Receptor	BE9-2562		Tubular Expansion Mullion (Male)	BY7-8474
	Head Receptor Stop Use with BE9-2562	E9-1033		Expansion Mullion (Female)	BE9-2525
	Horizontal Screw Spline Assembly	BE9-2522		90° Outside Corner Mullion	BE9-2507
	Glass Stop Use with BE9-2521 & BE9-2522	E9-2523		90° Inside Corner Mullion	BE9-2506
	Sill/Jamb Screw Spline Assembly	BE9-2513		135° Outside Corner Mullion	BE9-2504
	Sill Shear Block Assembly	BE9-2518		135° Inside Corner Mullion	BE9-2505
	4-1/2" Sill Screw Spline Assembly	BY7-9762		0°-12.5° Hinged Inside Corner Mullion (Male)	BE9-2524
	Thermal Sill Flashing	BE9-2578		0°-15° Hinged Outside Corner Mullion (Male)	BE9-2527
	One Piece Mullion Shear Block Assembly	BE9-2516		Hinged Corner Mullion (Female) Use with BE9-2524 or BE9-2527	BE9-2528
	Two Piece Mullion Screw Spline Assembly	BE9-2511		Two Piece Tubular Mullion Screw Spline Assembly	BY7-8473
	Flush Filler	E9-2512			

DOOR FRAMING MEMBERS



THERMAL
STANDARD

	Door Jamb For 25T/35T/50T Doors E2-0051 Not Included	BE9-1340		Door Jamb Use with AS-0409	E9-0490
	Snap-in Pocket Filler	E9-2546		Snap-in Pocket Filler	E9-2546
	Snap-in Filler	BE9-2571		Snap-in Filler Use With E9-0490 and BE9-1340 at Jamb Conditions	E9-0491
	Interior Transom Glass Stop Use With BE9-1342	E9-1343		Snap-in Filler	E9-1020
	Applied Exterior Transom Glass Stop Use With E9-1343 & FC-0808	BE9-1342		Intermediate Door Jamb Use with AS-0409	E9-9312
	Transom Bar For 25T/35T/50T Doors E2-0051 Not Included	BE9-1341		Applied Door Stop E2-0051 Elastomer Weath-ering Included	AS-0409
	Exterior Transom Head Glass Stop Use With BE9-1341	E9-2425		Door Stop Base Used with AS-0409	E9-1113
	Interior Transom Head Glass Stop Use With BE9-1341	E9-2536		Transom Jamb Pocket Adaptor	E9-2543
	Threshold 1/2" x 4-1/2" For 25T/35T/50T Doors	BE9-0465		Transom Bar E2-0051 Elastomer In-cluded	AS-0488
				OHCC Transom Bar	E9-0489
				OHCC Door Stop E2-0051 Elastomer In-cluded	AS-0718
				Exterior Transom Head Glass Stop	E9-2425
				Interior Transom Head Glass Stop	E9-2540
				Threshold 1/2" x 4"	E9-0407

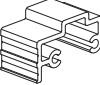



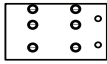



ACCESSORIES

	Glazing Adaptor For 1/4" Glazing	E9-1040		Setting Block For 1" Glazing Used with BY7-9762	E2-0020
	Glazing Adaptor For 1/2" & 3/4" IGU, 1/2" Laminated Monolithic	E9-1039		Setting Block Chair Use with E2-0177 Setting Block at Sill	E1-2530
	Glazing Gasket For 1" Glazing	E2-0052		End Dam For Sill Flashing	E1-0199
	Glazing Gasket For 3/4" Glazing	E2-0053		End Cap For Head Receptor BE9-2562	E1-2603
	Elastomer Weathering	E2-0051		Snap-in Filler Use with AS-2539 at Jamb Conditions	E1-1148
	Pile Weathering	E2-0062		Frame Filler (Optional) Use with BE9-2513 & BE9-2574	E3-0028
	Weathering Gasket Use with Expansion Mullions	E2-0065		Flat Filler (Optional) Use with BE9-2514 & BE9-2521	E3-0043
	Shear Block All Members - Inside Glazing Sill Only - Outside Glazing	E1-1145		Water Deflector	E2-0047
	Shear Block For Outside Glazing at Head and Intermediate Horizontal	E1-1144		1/2" "W" Side Block For Intermediate Vertical Deep Pocket	E2-0154
	Adaptor For High Sill Cover	E1-9871		1-1/8" "W" Side Block For Jamb	E2-0545
	Setting Block For Intermediate Horizontal	E2-0611		3/4" "W" Side Block Only at Thermal Transom Jamb Pocket	E2-0519
	Side Block For Intermediate Vertical Shallow Pocket	E2-0166		3/8" "W" Side Block Only at Standard Transom Jamb Pocket	E2-0533
	Setting Block For 1" Glazing Transom Head	E2-0104		Splice Sleeve For Sill Flashing BE9-2520 and Head Receptor BE9-2562	E2-0070
	Setting Block For Sill	E2-0177		Drill Fixture For Outside Glazing	H-7214

ACCESSORIES (Continued)

 <p>Setting Block For 1/4" Glazing</p>	<p>E2-0019</p>	 <p>Drill Fixture For Inside Glazing</p>	<p>H-7215</p>
 <p>Foam Backer Tape 1" x 1-1/4" (Roll)</p>	<p>E2-0259</p>		

FASTENERS

 <p>#8 x 3/8" PHSMS Zinc Plated Steel For Hinged Mullions</p>	<p>PC-0806</p>	 <p>#8 x 1/2" FHSMS Type AB, Zinc Plated Steel For Attachment of E9-2541 to Transom Jamb</p>	<p>FC-0808</p>
 <p>#10-24 x 3/8" PHMS, Stain- less Steel, For Attachment of Sill to Sill Flashing</p>	<p>PM-1006 -SS</p>	 <p>#12 x 1/2" FHSMS Type AB, Zinc Plated Steel For Attachment of End Cap E1-2603 to Receptor</p>	<p>FC-1208</p>
 <p>#12 x 5/8" PHSMS Type AB, Zinc Plated Steel, For Attach- ment of horizontals to shear blocks</p>	<p>PC-1210</p>	 <p>#10-32 x 2" FHSMS Zinc Plated Steel, For Attachment of OHCC Door Stop</p>	<p>FN-1032</p>
 <p>#12 x 1-1/4" PHSMS Type AB, Zinc Plated Steel, For Screw Spine Attach- ment</p>	<p>PC-1220</p>	 <p>#12 x 3/4" UFHSMS Type A, Zinc Plated Steel For End Dam Attachment</p>	<p>UA-1212</p>
 <p>#12 x 1-3/4" PHSMS Type AB Zinc Plated Steel, For Attachment of Shear Block to Vertical</p>	<p>PC-1228</p>		

FRAME FABRICATION

STEP 1 DETERMINE FRAME SIZE

Determine Frame Width:

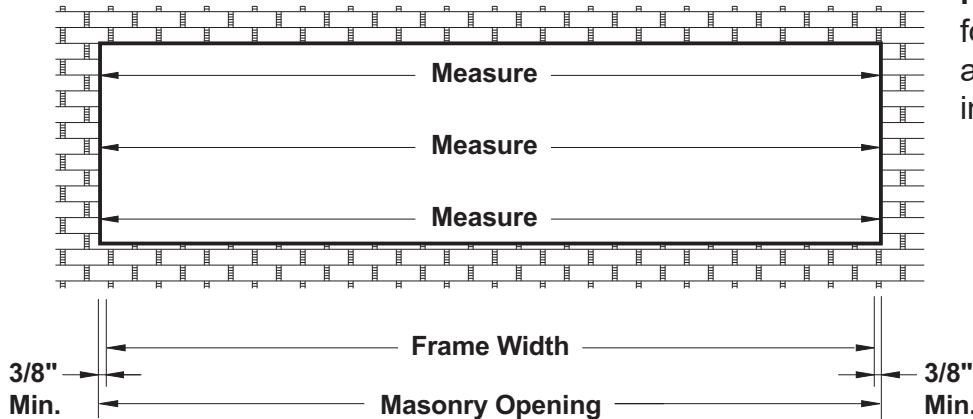

Note: Check the opening for squareness and plumb at both ends. Units must be installed in a true rectangle.

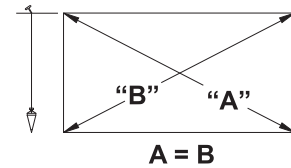

Detail 1

- Measure the width of the masonry opening at the top, middle and bottom.
- Select the smallest dimension measured and subtract 3/4" to the determine the frame width to be used.

See **Detail 1**.

NOTE: Frame widths over 24'-0" require expansion mullions every 12 to 15 feet (best location at mullion next to the door jamb.)

Determine Frame Height:

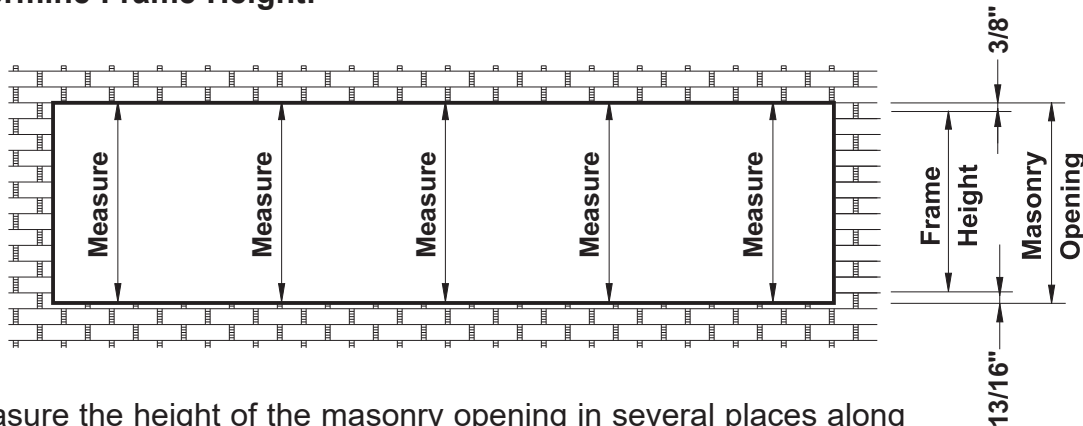

- Measure the height of the masonry opening in several places along the entire length of the opening.
- Select the smallest dimension measured and subtract 1-3/16" to determine the frame height to be used:

Minimum 3/8" shim/caulk joint at the head.

7/16" for sill flashing.

Minimum 3/8" shim/caulk joint below the sill flashing.

See **Detail 2**.

Detail 2

FRAME FABRICATION

STEP 1

DETERMINE FRAME SIZE

Determine Frame Height for Receptor Conditions:

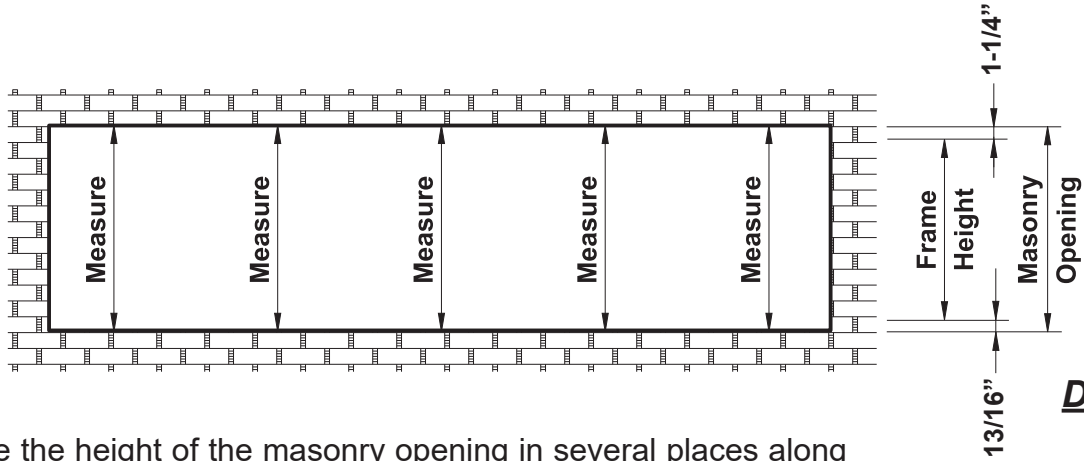

Detail 3

-Measure the height of the masonry opening in several places along the entire length of the opening.

-Select the smallest dimension measured and subtract 2-1/16" to determine the frame height to be used:

Minimum 3/8" shim/caulk joint at the head.

7/8" for the head receptor

7/16" for sill flashing.

Minimum 3/8" shim/caulk joint below the sill flashing.

See **Details 3 & 4**.

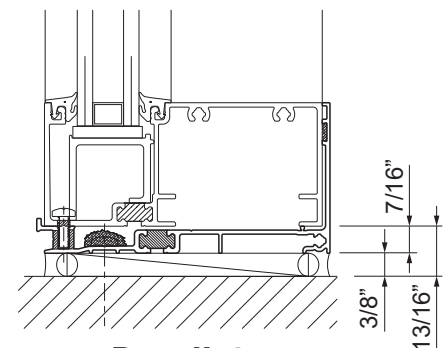
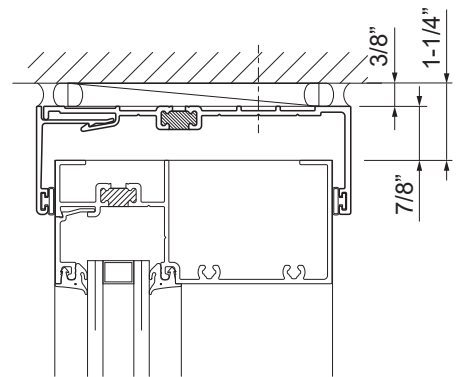

Detail 4

FRAME FABRICATION

**STEP 2
FABRICATE TWO PIECE MULLIONS
FOR SCREW SPLINE ASSEMBLY**

-Cut the two piece mullion and jamb members to the frame height determined in Step 1.
-Fabricate holes in mullions for screw spline attachment using one of the methods below:

1. Layout the hole locations as shown in **Detail 5** and drill a 0.234" dia. (#B drill bit) clearance hole at each location marked, or per drill fixture. For Tubular mullion drill a 0.500" dia. access hole as shown.
2. Use punch press with appropriate die set.

See **Detail 5**.

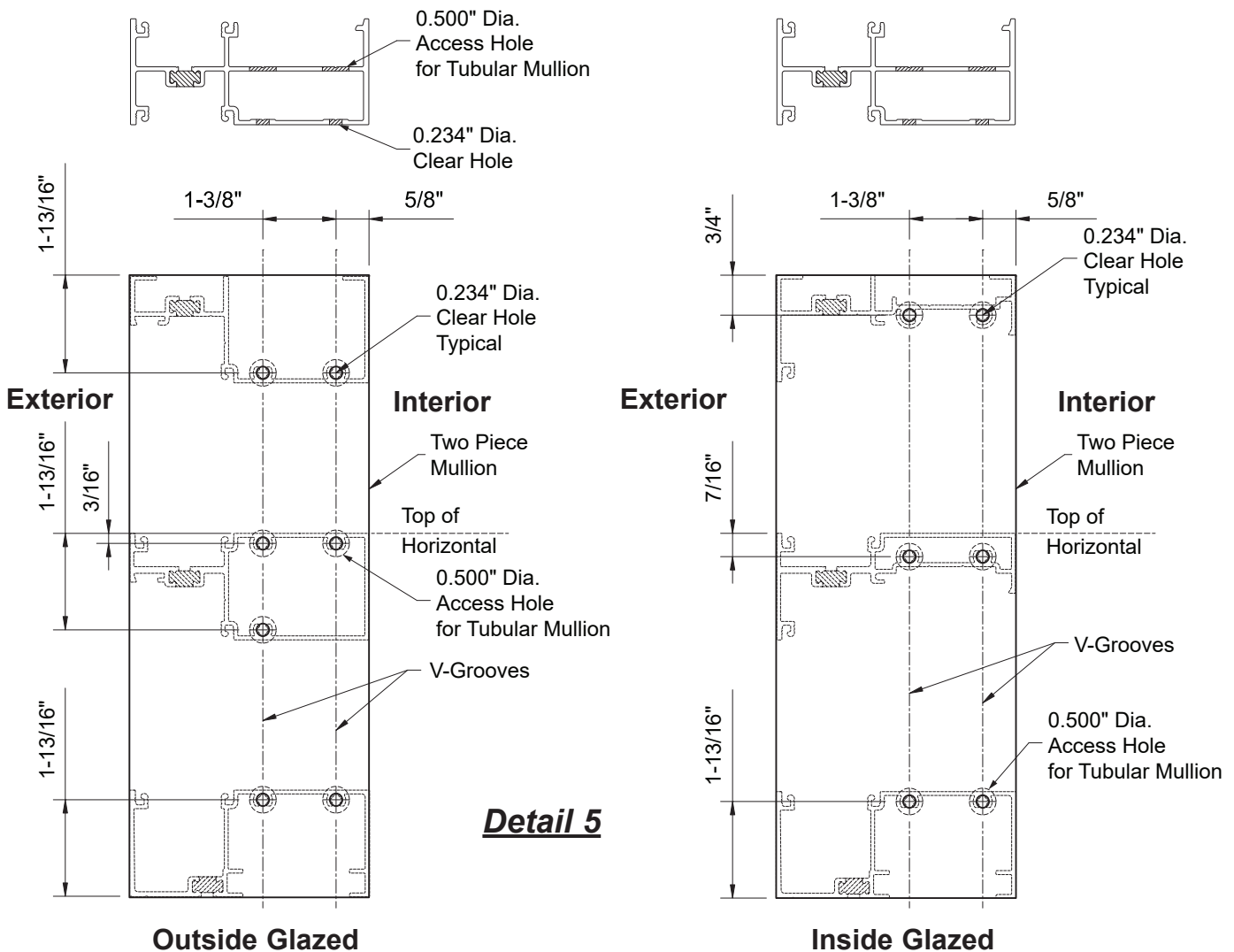

FRAME FABRICATION

STEP 2 (Continued)

FABRICATE TUBULAR MULLIONS FOR SHEAR BLOCK ASSEMBLY

- Cut the vertical and jamb members to the frame height determined in Step 1.
- Tubular verticals require shear blocks for the attachment of head, horizontal and sill members:

Note: Open back horizontals, BE9-2517, must be used when using shear blocks.

- Mark the location for each shear block using one of the methods below:

1. Layout the shear blocks as shown in **Detail 6**.

- Drill a 0.188" diameter hole (#12 or 3/16" drill bit) at each location marked.

- Attach the shear blocks to the verticals using two (2) PC-1228 fasteners.

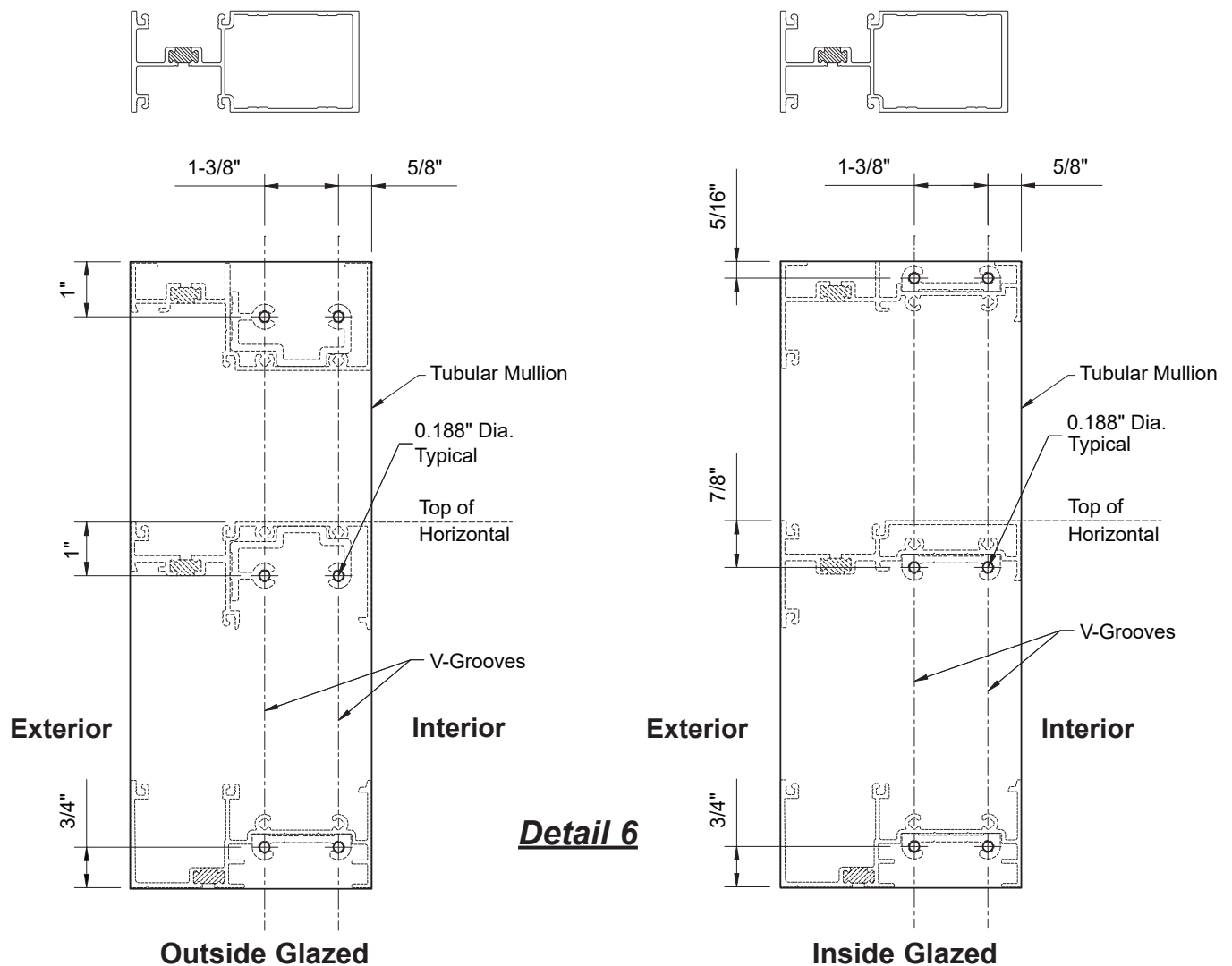

FRAME FABRICATION

STEP 2 (Continued)

**FABRICATE SNAP-IN FILLER FOR STANDARD AND CORNER MULLIONS
– SCREW SPLINE ASSEMBLY**

-Cut the E9-2512 snap in fillers to the frame height determined in Step 1.
-Fabricate holes in vertical mullions for screw spline attachment using one of the methods below:

1. Layout the hole locations as shown in **Detail 7** and drill a 0.234" dia. (15/64" drill bit) clearance hole at each location marked.
2. Use punch press with appropriate die set.

See **Detail 7**.

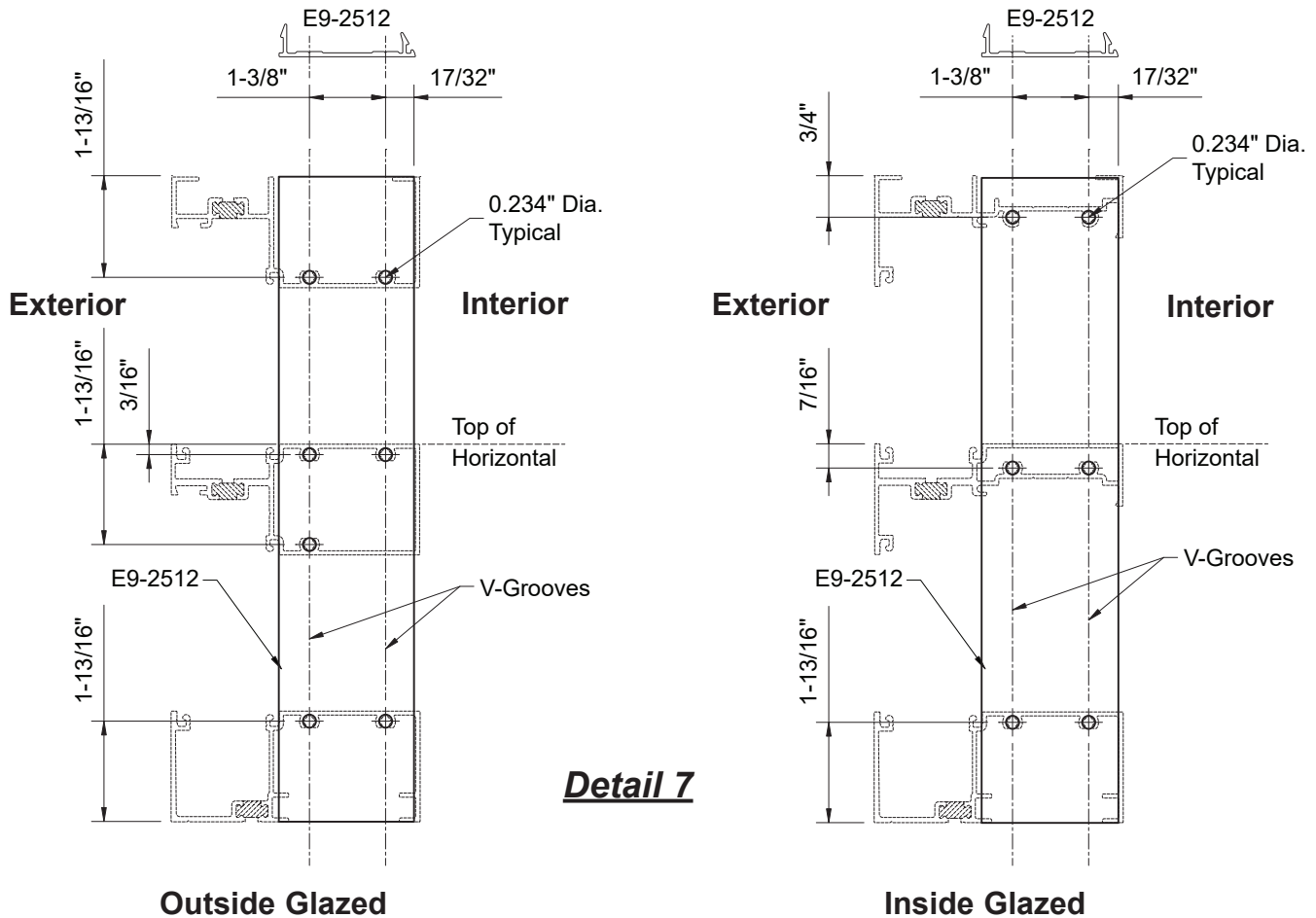

FRAME FABRICATION

STEP 2 (Continued)

FABRICATE CORNER MULLIONS FOR SHEAR BLOCK ASSEMBLY

- Cut the E9-2512 snap in fillers to the frame height determined in Step 1.
- Tubular mullions require shear blocks for the attachment of head, horizontal and sill members:

Note: Open back horizontals, BE9-2517, must be used when using shear blocks.

- Mark the location for each shear block using one of the methods below:

1. Layout the shear blocks as shown in **Detail 8**.

- Drill a 0.188" diameter hole (#12 or 3/16" drill bit) at each location marked.

- Attach the shear blocks to the verticals using two (2) PC-1228 fasteners.

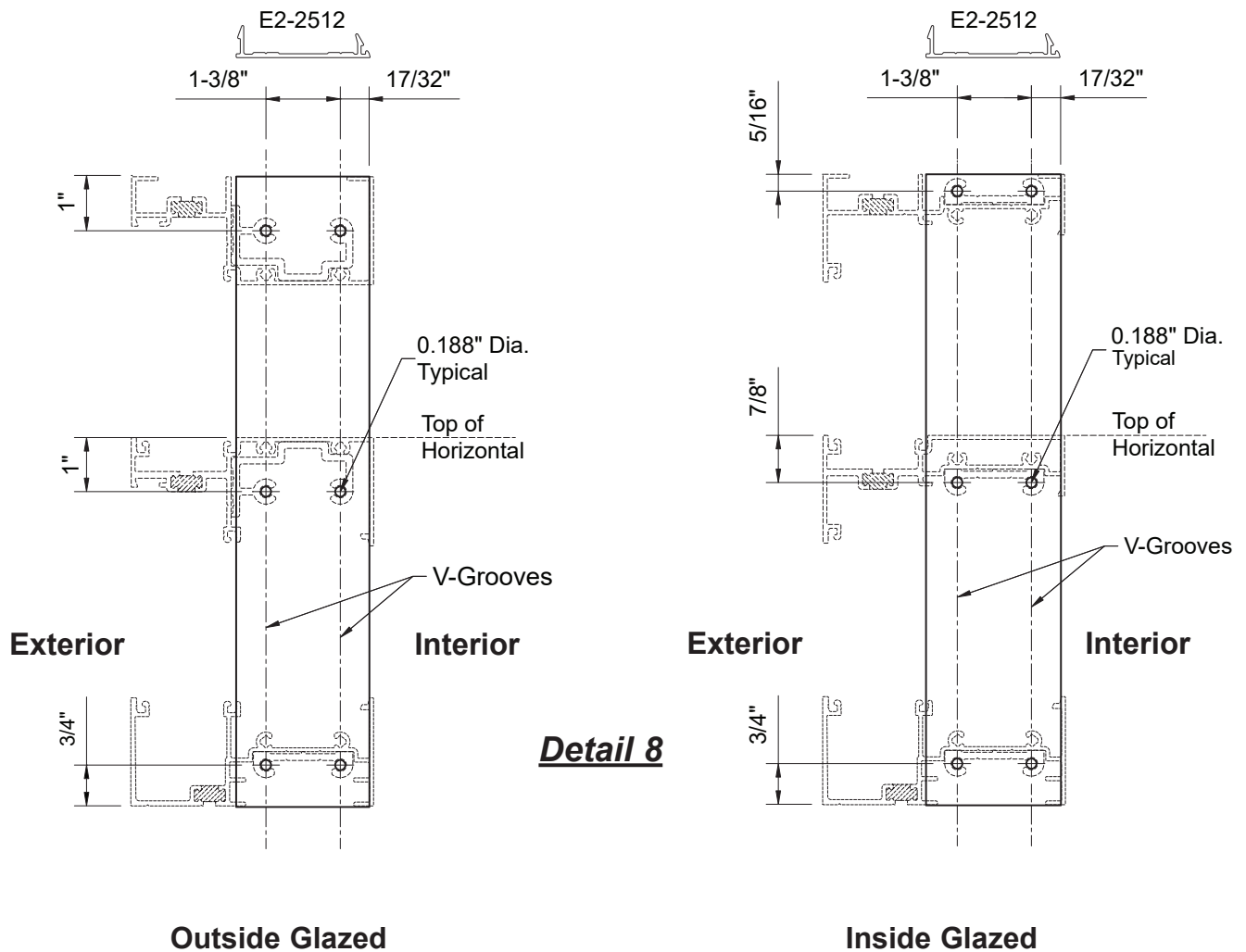

FRAME FABRICATION

STEP 3

FABRICATE HEAD, INTERMEDIATE HORIZONTAL MEMBERS FOR INSIDE GLAZING

- Cut head, intermediate horizontal, and sill members to the daylight opening (D.L.O.) as indicated on the shop drawings.
- Intermediate horizontal members that will be attached to shear blocks require additional fabrication:

BE9-2521 Head Members:

- Mark hole location at each end, 7/8" from the ends and centered along the "V"-groove.
 - Drill a 0.234" diameter hole (15/64" drill bit) at each location marked for a #12 (PC-1210) fastener.
- See **Detail 9**.

BE9-2522 Intermediate Horizontal Members:

- Mark a hole location at each end, 7/8" from the ends centered along the "V"-groove.
 - Drill a 0.234" diameter hole (15/64" drill bit) at each location marked.
- See **Detail 10**.

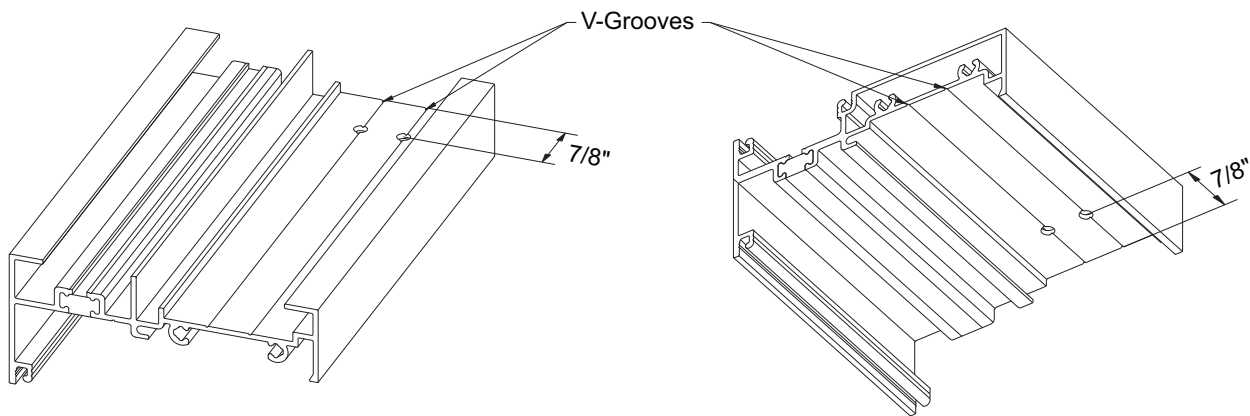

Detail 9
HEAD

Detail 10
HORIZONTAL

FRAME FABRICATION

STEP 3 (Continued)

FABRICATE HEAD, INTERMEDIATE HORIZONTAL MEMBERS FOR OUTSIDE GLAZING

- Cut head, horizontal, and sill members to the daylight opening (D.L.O.) as indicated on the shop drawings.
- Intermediate horizontal members that will be attached to shear blocks require additional fabrication:

BE9-2514 Head Members:

- Mark hole location at each end, $7/8$ " from the ends and centered along the "V"-groove.
- Drill a 0.234" diameter hole ($15/64$ " drill bit) at each location marked for a #12 (PC-1210) fastener.
See **Detail 11**.

BE9-2515 (BE9-2517 at End Bay) Intermediate Horizontal Members:

- Mark a hole location at each end, $7/8$ " from the ends centered along the "V"-groove.
- Drill a 0.234" diameter hole ($15/64$ " drill bit) at each location marked.
See **Detail 12**.

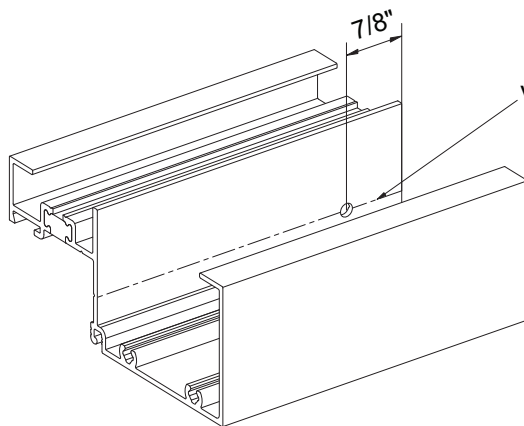

Detail 11
HEAD

V-Groove

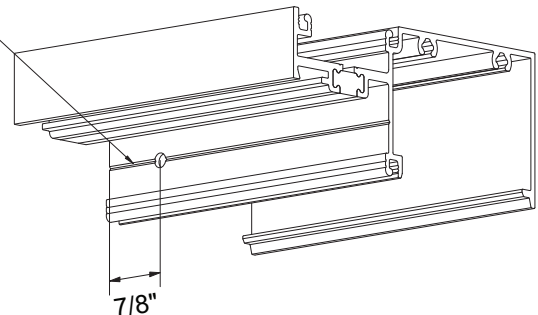

Detail 12
HORIZONTAL

FRAME FABRICATION

**STEP 4
FABRICATE SILL FLASHING**

Note: Sill flashing is required in all conditions including continuous head and sill.

For elevations without door framing:

-Cut sill flashing, BE9-2578 to the end of the frame plus (+) 1/8" at each jamb.

For elevations with door framing:

-Cut the sill flashing from the end of the frame to the door jamb plus (+) 1/8".
(See approved shop drawings for this dimension)

See **Detail 13**.

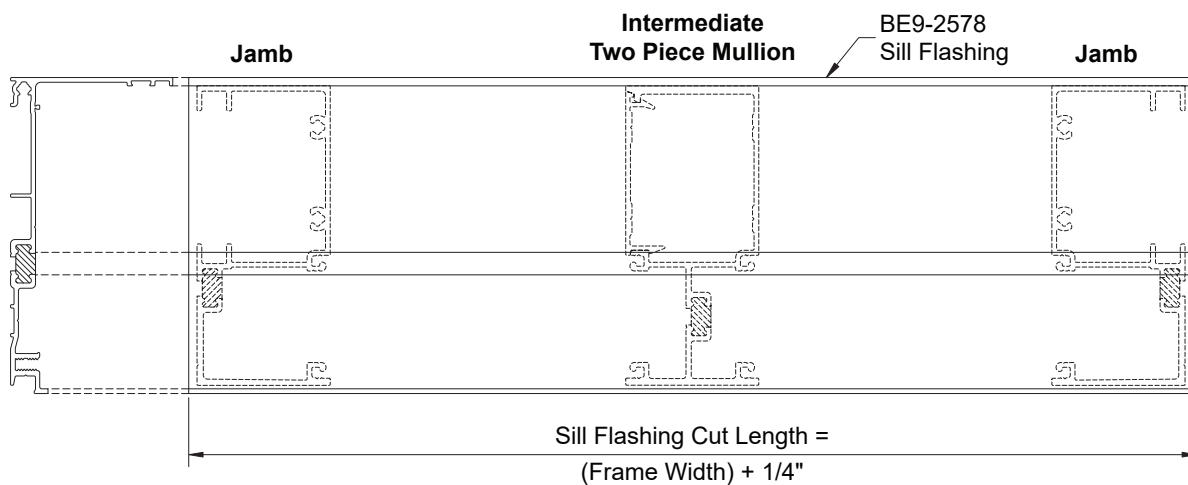

DETAIL 13

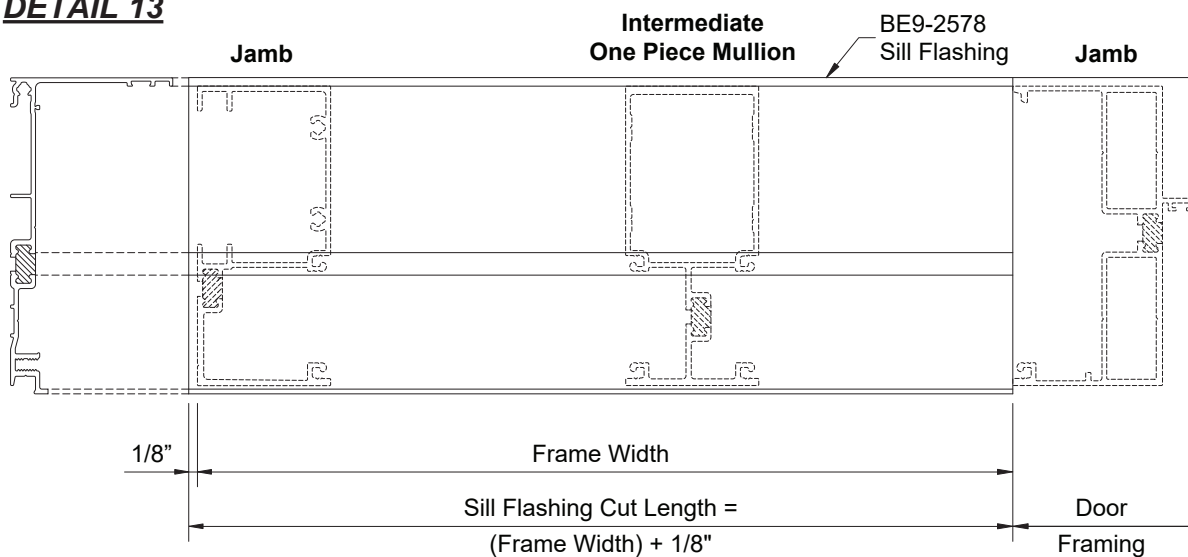

FRAME FABRICATION

STEP 4 (Continued) FABRICATE SILL FLASHING

- For openings longer than 24'-0" the sill flashing needs to be spliced every twelve to fifteen feet.
- Allow for a 3/8" joint between sill flashing members.
- Mark the quarter points between vertical mullions on the sill flashing.

See **Detail 14**.

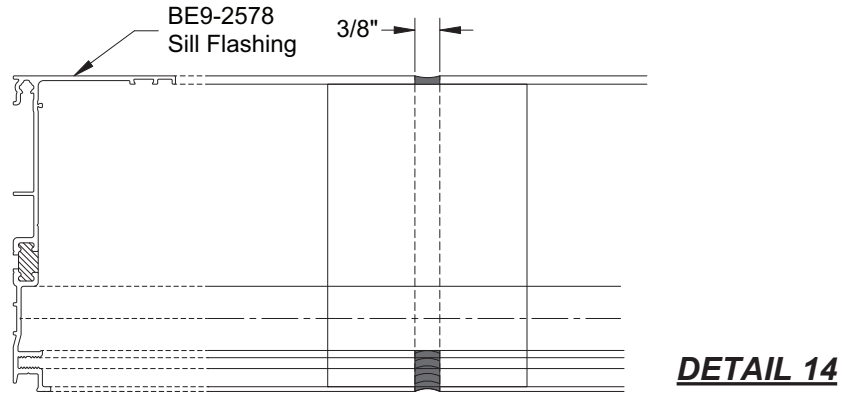

- Mark and drill a 5/16" diameter weep hole in the front of the sill flashing at each D.L.O. quarter point.

See **Detail 15**.

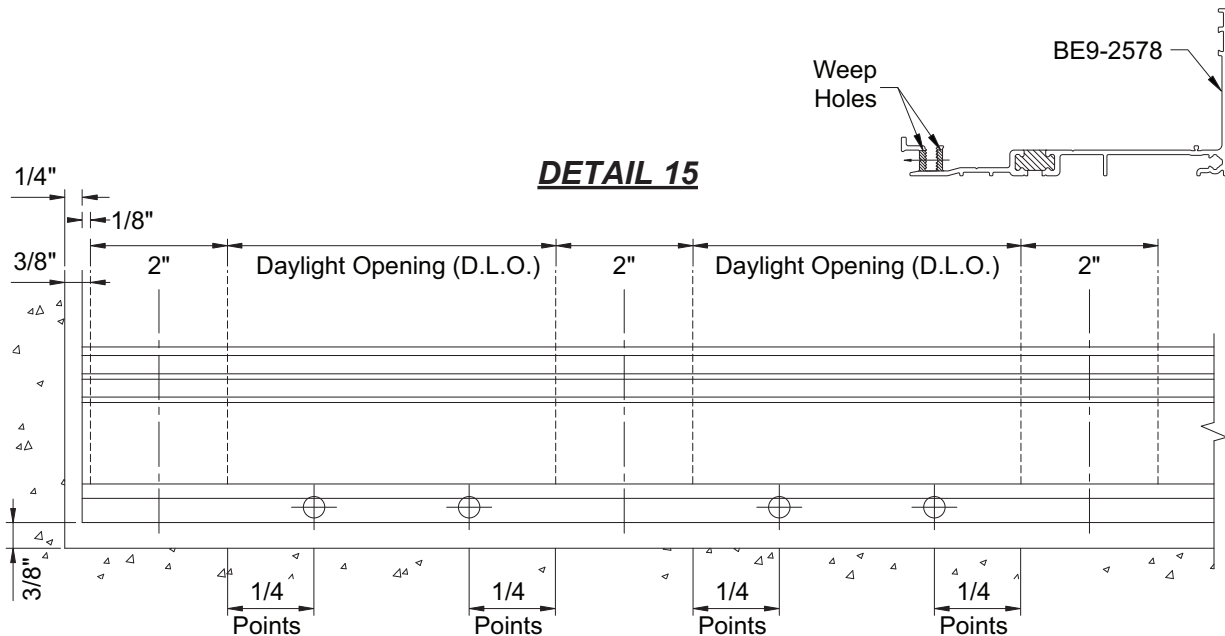

FRAME FABRICATION

**STEP 4A
FABRICATE HEAD RECEPTOR**

- Cut the head receptor BE9-2562 and the E9-1033 snap cover to the frame width + 1/8" at each jamb or as indicated on the approved shop drawings.
 - At each jamb, drill two Ø0.189" tap holes in to the BE9-2562 head receptor as shown.
 - For openings longer than 24'-0" the head receptor needs to be spliced every twelve to fifteen feet at the center of a D.L.O.
 - Allow for a 3/8" joint for expansion between head receptor members.
- See **Detail 16**.

* **Note:** The Ø0.189" tap hole in the exterior side of the receptor will be slightly off the V-Groove. Drilling this hole from the top side of the receptor after the interior side hole is recommended.

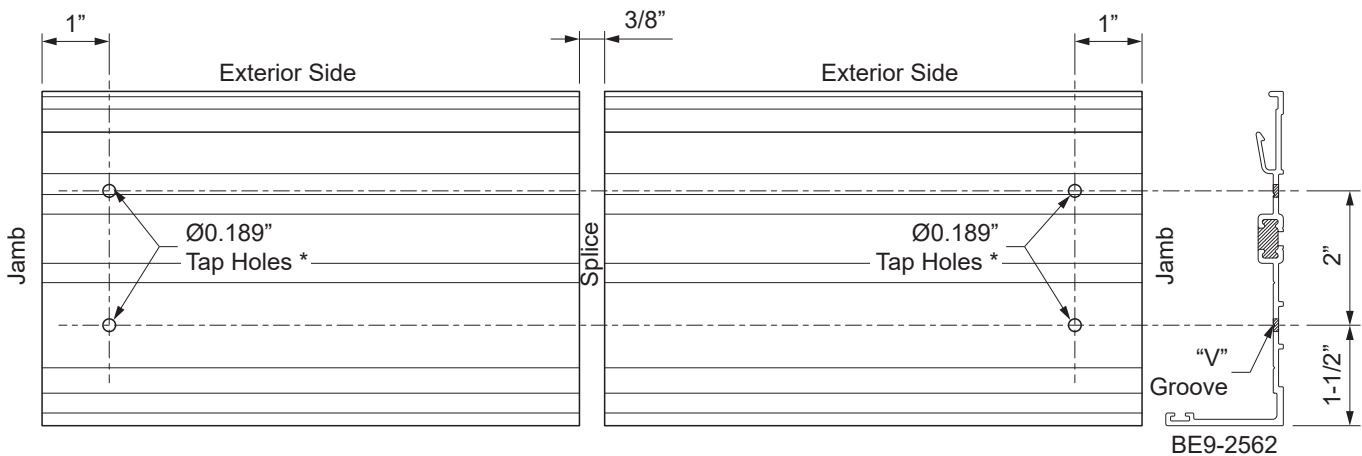

DETAIL 16

FRAME FABRICATION

STEP 5 FABRICATE SILL MEMBERS

- Cut sill members to the daylight opening dimension between verticals.
- For end reactions over 500 lbs., fabricate sill members for anchoring to sill flashing:
 - Measure in 6" from each end of the sill member and mark hole locations along the "V"-groove located on bottom of profile as shown in **Detail 17**.
 - Mark additional hole locations a maximum of 24" on center (O.C.).
 - Drill a 0.213" diameter (#3 drill bit) hole at each location marked. See **Detail 17**.

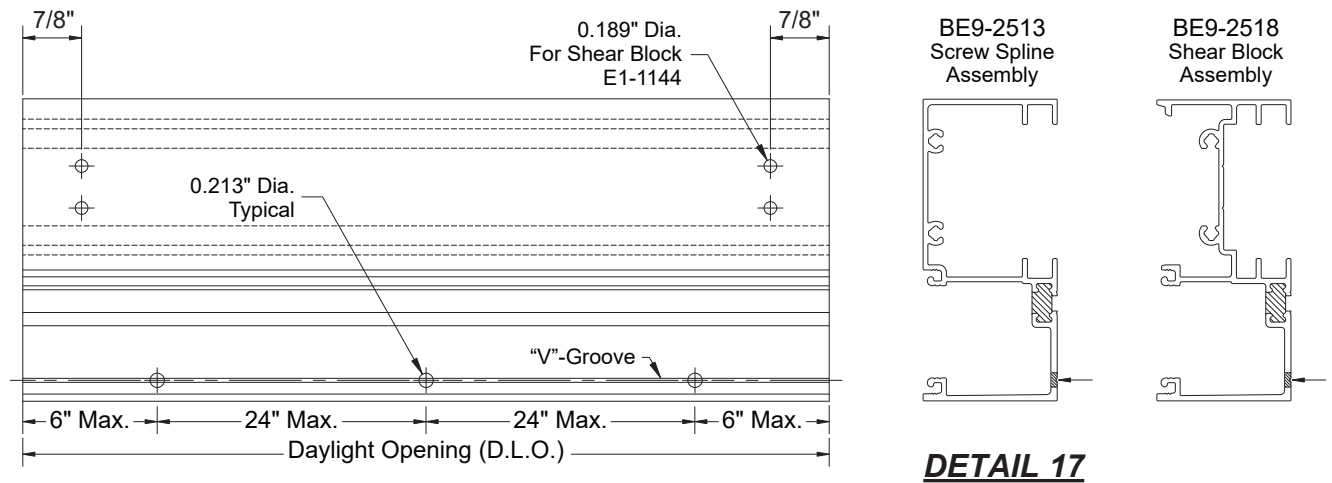

FRAME FABRICATION

**STEP 6
FABRICATE GLASS STOPS**

- Cut glass stops to Daylight Opening Minus(-) 1/32".
- Cut glazing adaptors to Daylight Opening Minus(-) 1/32".
- Cut horizontal flat fillers to Daylight Opening Minus(-) 1/32".

See **Detail 18**.

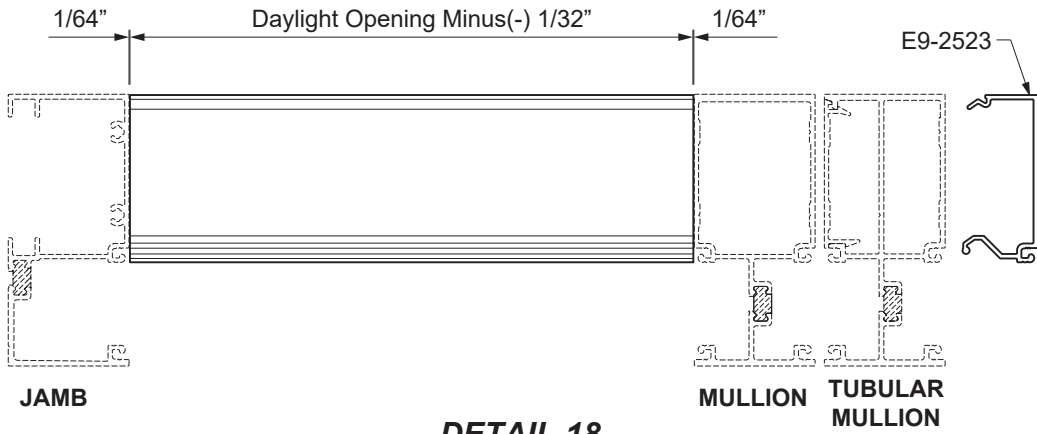

DETAIL 18

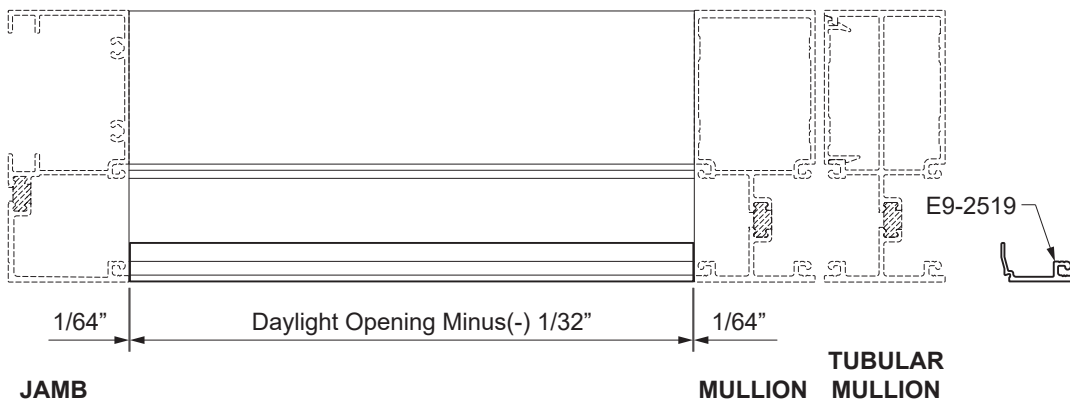

FRAME ASSEMBLY

STEP 7 ASSEMBLE FRAMES

Inside Glazed Screw Spline Assembly:

- Clean all joint surfaces using cleaner approved by sealant manufacturer.
- Apply sealant to both ends of head, intermediate horizontal, and sill members just prior to assembly.
- Attach head, intermediate horizontal and sill members to vertical members with two PC-1220 fasteners at each end as shown below.
- Tool the sealant into the joints and wipe away any excess sealant.

See **Detail 19**.

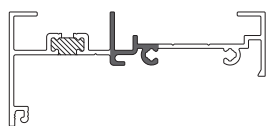

BE9-2521

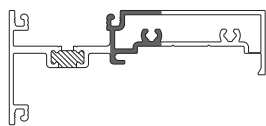

BE9-2522

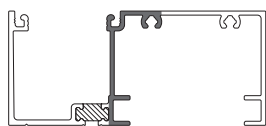

BE9-2513

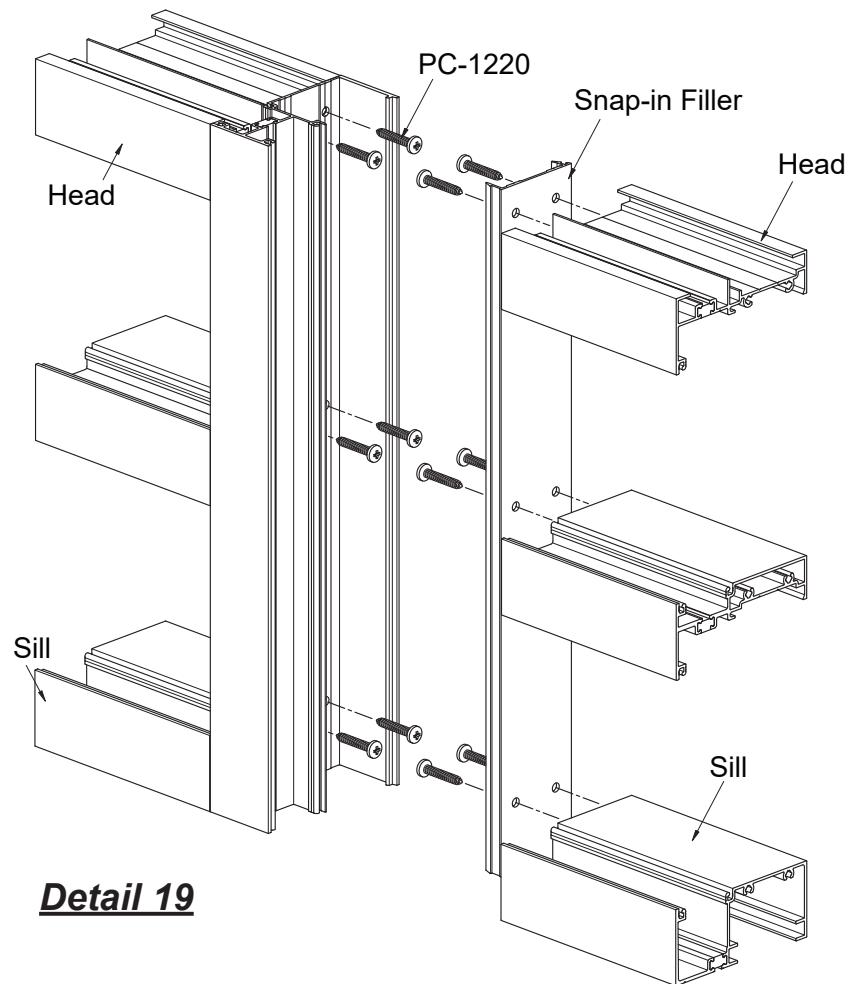

Detail 19

Apply sealant to the shaded areas at each end.

CAUTION: Always assemble frames such that each lite of glass will have a minimum of one deep vertical glazing pocket.

FRAME ASSEMBLY

STEP 7 (Continued) ASSEMBLE FRAMES

Outside Glazed Screw Spline Assembly:

- Clean all joint surfaces using cleaner approved by sealant manufacturer.
- Apply sealant to both ends of head, intermediate horizontal, and sill members just prior to assembly.
- Attach head, intermediate horizontal, and sill members to vertical members with two PC-1220 fasteners at each end as shown below.
- Tool the sealant into the joints and wipe away any excess sealant.

See **Detail 20**.

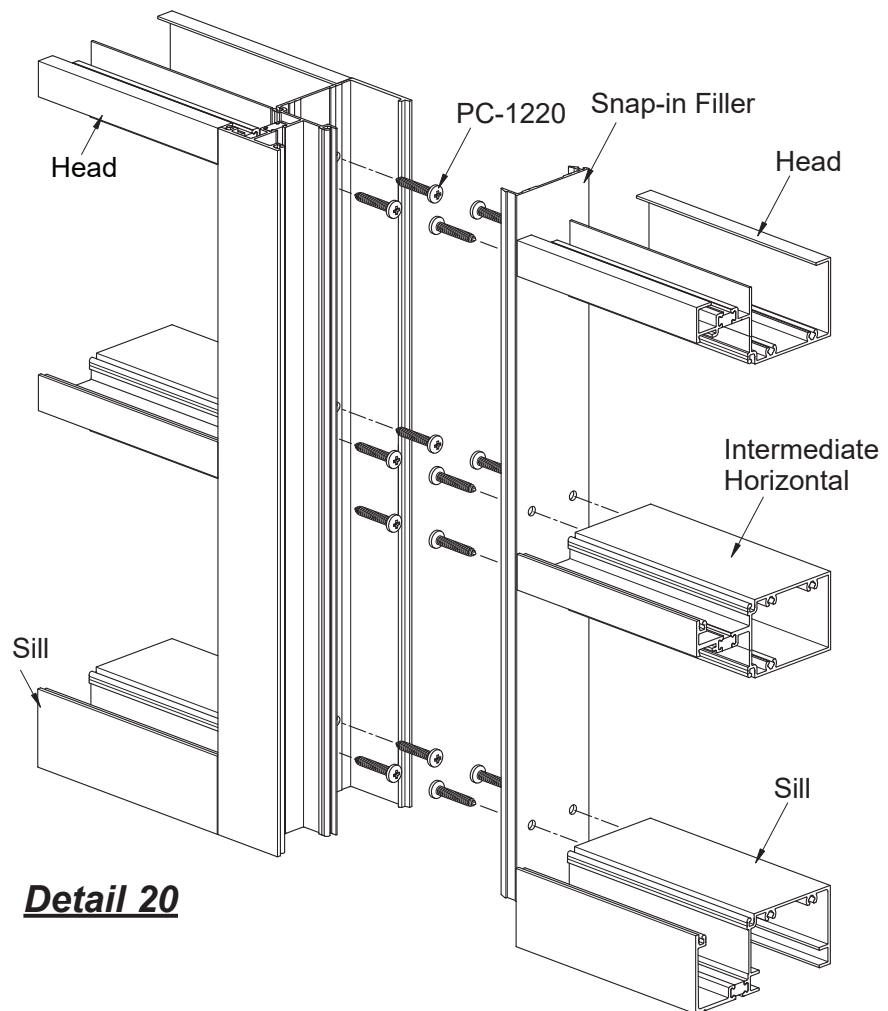
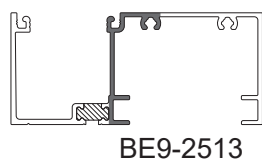
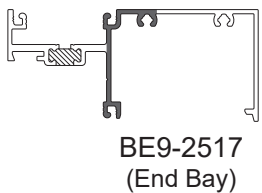
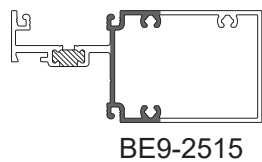
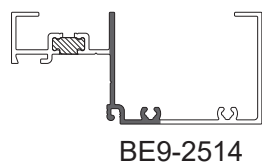

Apply sealant to the shaded areas at each end.

CAUTION: Always assemble frames such that each lite of glass will have a minimum of one deep vertical glazing pocket.

FRAME ASSEMBLY

STEP 7 (Continued) ASSEMBLE FRAMES

Inside Glazed Shear Block Assembly:

- Clean all joint surfaces using cleaner approved by sealant manufacturer.
- Apply sealant to both ends of head, intermediate horizontal, and sill members.
- Apply sealant to the shear blocks as shown.
- Attach shear blocks to verticals with PC-1228 fasteners as shown.
- Attach head, horizontal, and sill members to shear blocks at each end with two (2) PC-1210 fasteners.

See **Detail 21**.

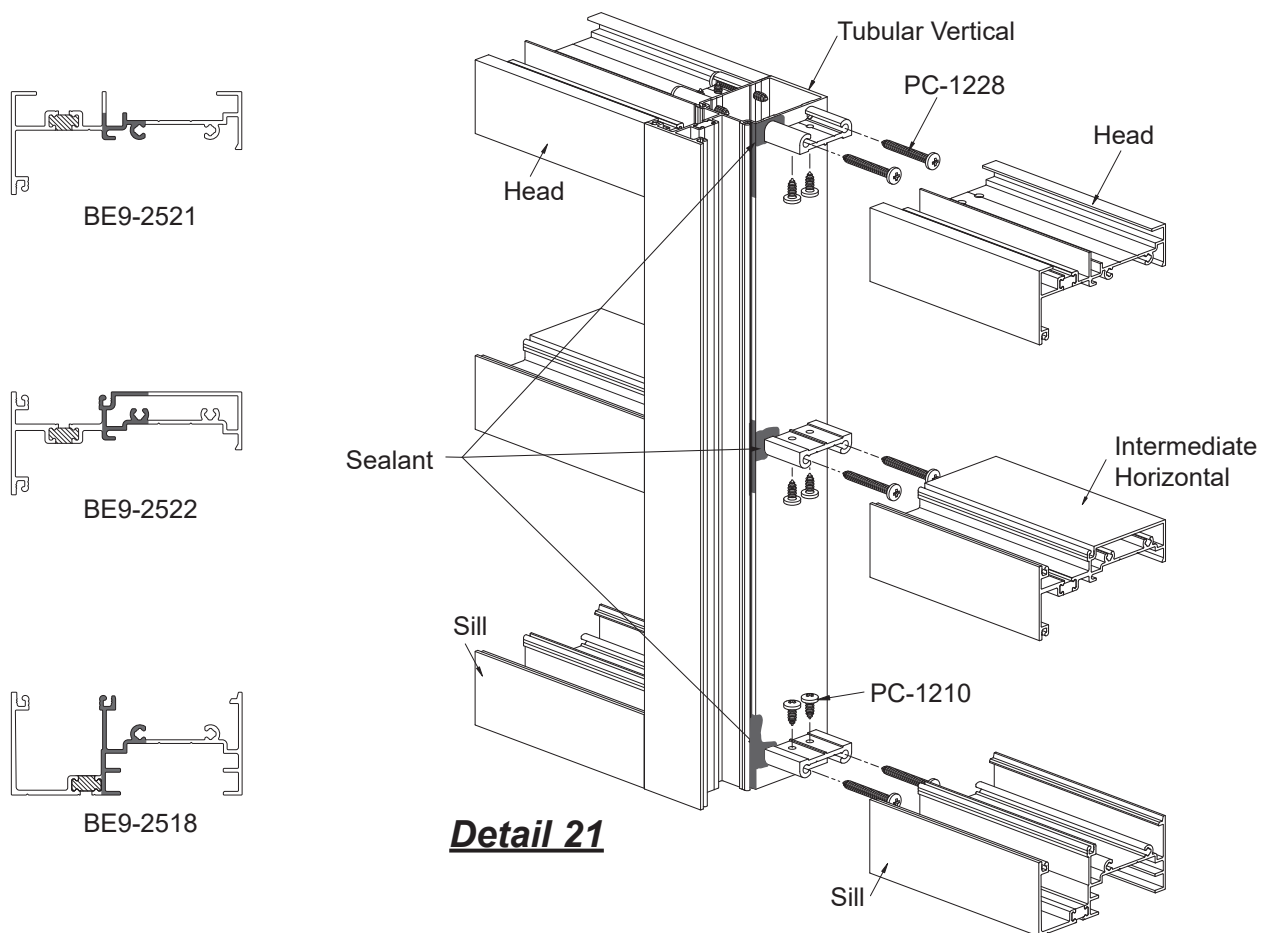

Detail 21

Apply sealant to the shaded areas at each end.

CAUTION: Always assemble frames such that each lite of glass will have a minimum of one deep vertical glazing pocket.

FRAME ASSEMBLY

STEP 7 (Continued) ASSEMBLE FRAMES

Outside Glazed Shear Block Assembly:

- Clean all joint surfaces using cleaner approved by sealant manufacturer.
- Apply sealant to both ends of head, intermediate horizontal, and sill members.
- Apply sealant to the shear blocks as shown.
- Attach shear blocks to verticals with PC-1228 fasteners as shown.
- Match drill shear block with 3/16" (#12 drill bit) hole for PC-1210 fastener.
- Attach head and horizontal members to shear blocks at each end with one (1) PC-1210 fastener.
- Attach sill members to shear blocks at each end with two (2) PC-1210 fasteners.

Note: Open back horizontals must be used with shear blocks at end bays.

See **Detail 22**.

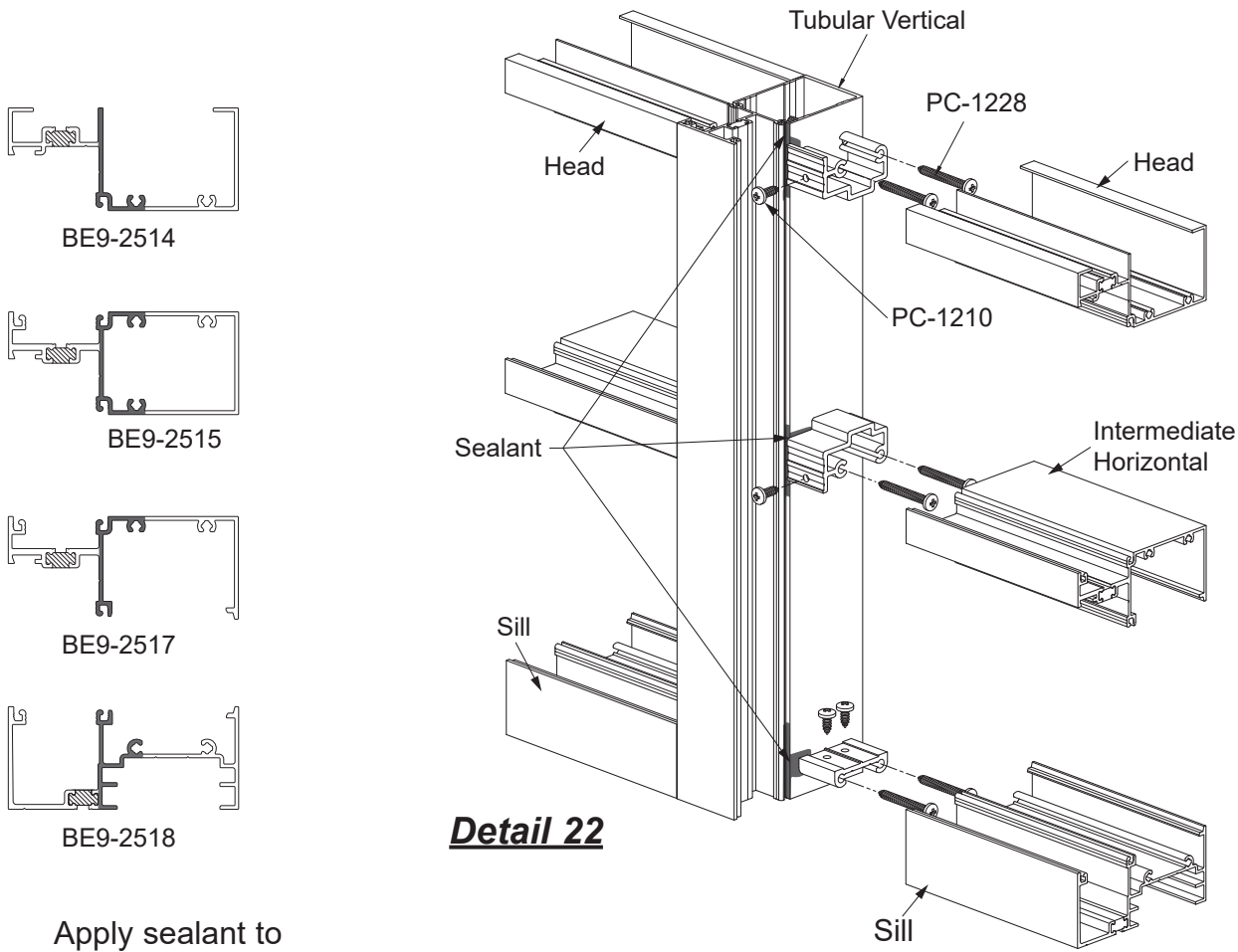

Apply sealant to the shaded areas at each end.

CAUTION: Always assemble frames such that each lite of glass will have a minimum of one deep vertical glazing pocket.

FRAME ASSEMBLY

STEP 8 (Not necessary with Head Receptor) INSTALL FOAM PLUGS AT HEAD

- Cut pieces of E2-0259 foam backer tape (maximum 1-3/4" long for typical mullion) to be adhered at the head only.
These will serve as end cap support for perimeter backer rods and sealant.
- Peel the adhesive tape from the foam pieces and adhere them to the front and back of the mullion as shown in **Detail 23**. The foam can be easily compressed to accommodate obstacles in the assembled verticals.
- Seal over the glazing pocket cavities in the front of the mullion.

Notes: For best adhesion, ensure the contact surfaces of the verticals are clean and dry.
Backer tape application is similar for expansion and corner mullions

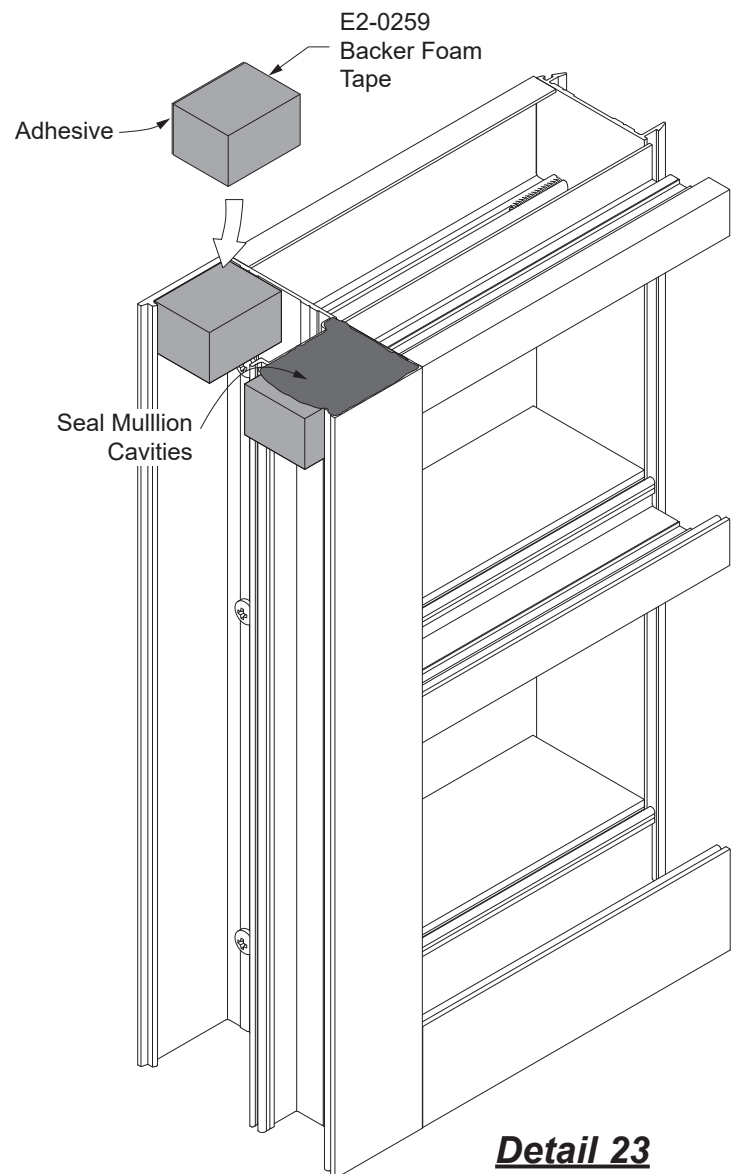

FRAME ASSEMBLY

**STEP 7 (Continued)
ASSEMBLE FRAMES**

Attach Corner Assemblies:

- Attach horizontal members to standard mullions as previously shown.
- Attach the other end of the horizontals to the corner mullions, hinged mullions, or flat fillers, or using the same technique.
- Snap the corner framing members together to form the corner assemblies.
- Hinged mullions must be fastened through the ball joint 6" from each end and no more than 18" on center with PC-0806 fasteners.
- Carefully move the corner assembly into place and snap it into the rest of the frame one side at a time.

See **Detail 23**.

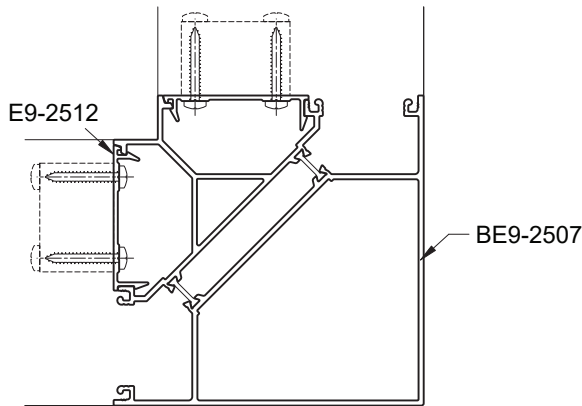

90° Outside Corner
(Inside Corner Similar)

Detail 23

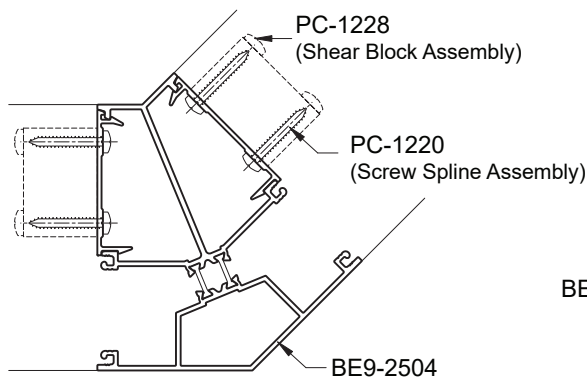

135° Outside Corner
(Inside Corner Similar)

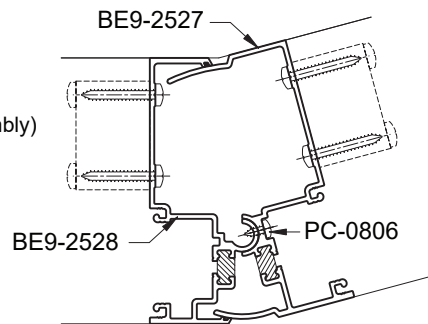

0°-15° Outside Corner
(Inside Corner Similar)

STEP 7 (Continued)

INSTALL EXPANSION MULLIONS WHERE REQUIRED

- Expansion mullions require the E2-0065 weathering gasket in both front and rear reglets.
- During installation, the current air temperature should be taken into account to determine the proper spacing between the mullion halves such that the expansion mullion stays within its allowable width limits during its service in hot and cold weather conditions.
- Fill the interior gap between the mullion halves with sealant at the sill flashing and head receptor.

See **Detail 24**.

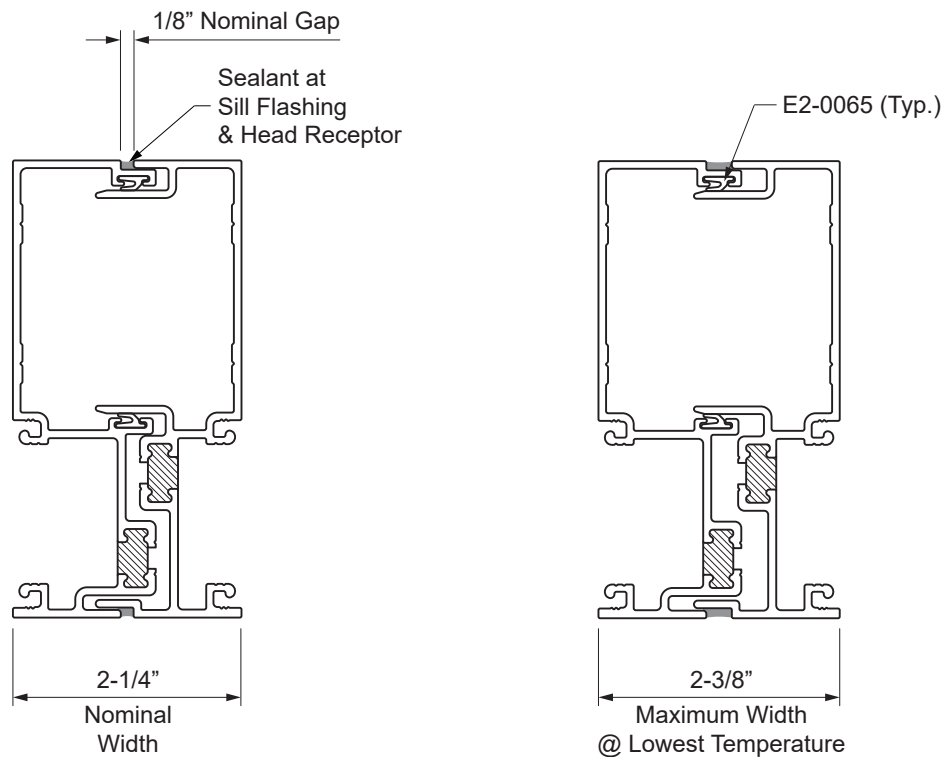

Detail 24

FRAME INSTALLATION

**STEP 8
INSTALL SILL FLASHING END DAMS**

- Hold the end dam with one hand and grab the tab with a pair of pliers.
- Bend the end dam tab left or right 90 degrees in order to “hand” the end dam for the left or right end of the flashing.

See **Detail 25 & 26.**

- Clean all joint surfaces using cleaner approved by sealant manufacturer.
- Apply sealant to the end of the sill flashing as shown in **Detail 27.**
- Slide the tab into the top portion of the sill flashing.
- Tap the tab into place with a small tool until the end dam is snug against the end cut of the flashing.
- Fasten the end dam to the sill flashing with two UA-1212 screws, starting at the back, followed by the front as shown in **Detail 27.**

- Tool sealant along the joint between the end dam and the sill flashing as shown in **Detail 28.**
- Seal over any exposed screw threads.

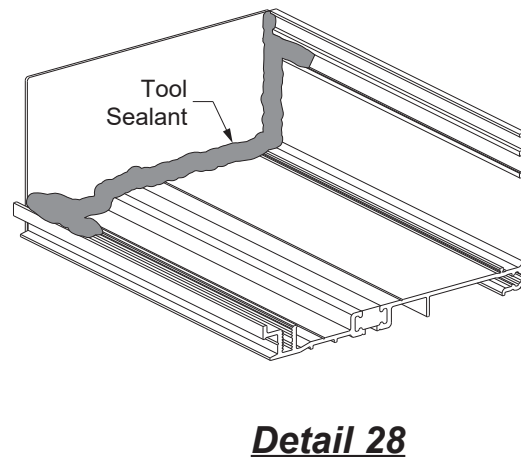
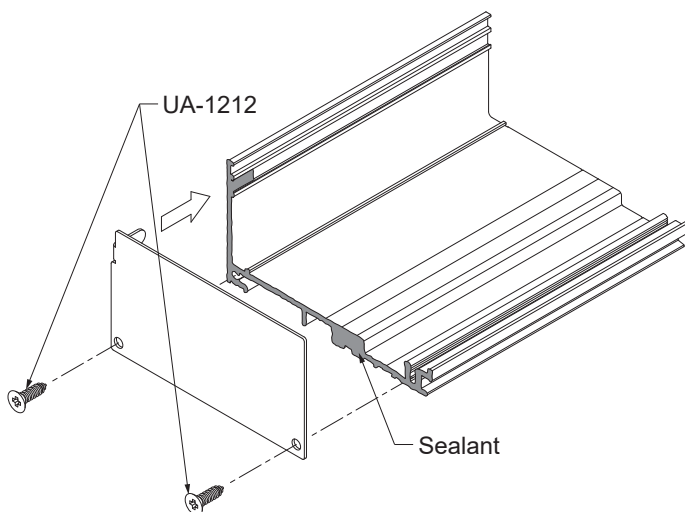
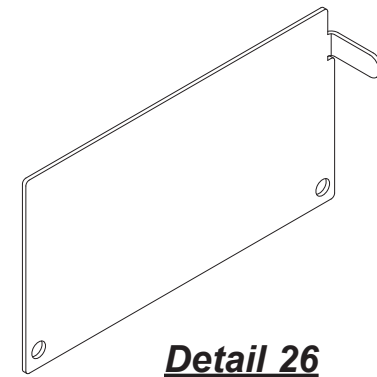
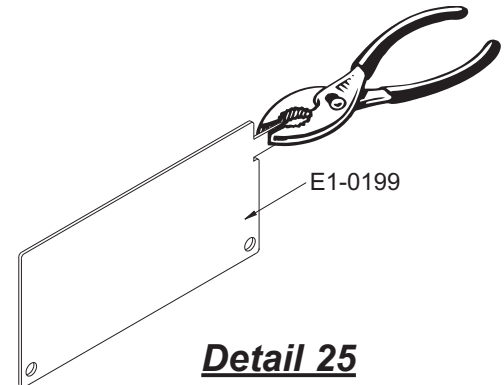

Detail 27

Detail 28

FRAME INSTALLATION

STEP 9 INSTALL SILL FLASHING

- Install the sill flashing with a minimum of 3/8" shim underneath. Sill flashing must be installed level.
- Anchor the sill flashing to the structure a maximum of 4" from each end and then 18" to 24" on center.
- Apply and tool sealant to cover the heads of all anchors.

STEP 10 INSTALL SILL FLASHING SPLICE SLEEVE

- Remove the nub with a chisel or pliers 1-1/2" on both sides of splice joint as shown in **Detail 29**.
- After the sill flashing has been shimmed and installed to the building structure, insert a small backer rod under the sill flashing as shown in **Detail 30**.
- Position the Silicone Splice Sleeve against the back wall below the groove.
- Bend the Silicone Splice Sleeve into the front on the channel as shown. Mark and cut the sleeve at this position.
- Clean Sill Flashing and Silicone Splice Sleeve with isopropyl alcohol at the splice location.
- Seal the flashing at the splice location as shown in **Detail 30**, before positioning the flashing. Set the Silicone Splice Sleeve into the Silicone Splice Sleeve.
- Tool sealant tight as shown in **Detail 31**, squeezing the sheet flat with a seam roller.

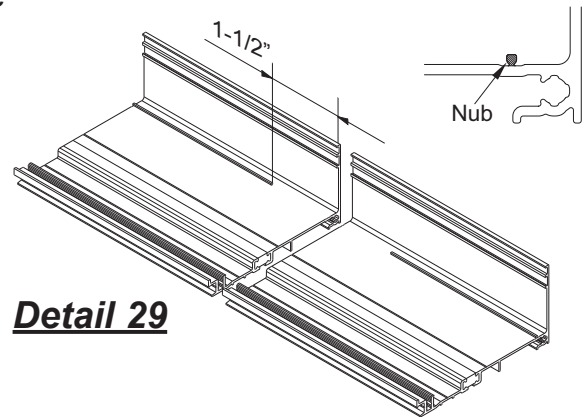

Detail 29

When using E2-0070, a compatible Silicone Sealant must be used at the splice. Compatible Silicone Sealants include Tremco® Spectrem 2® and Dow Corning® 795.

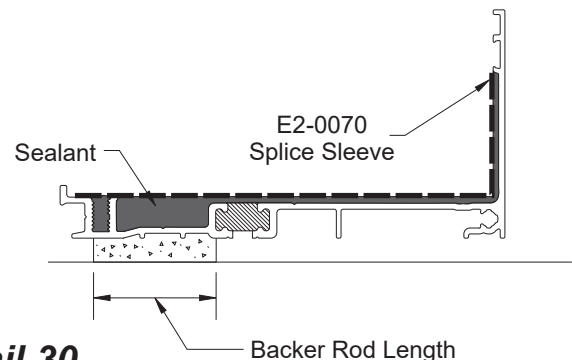
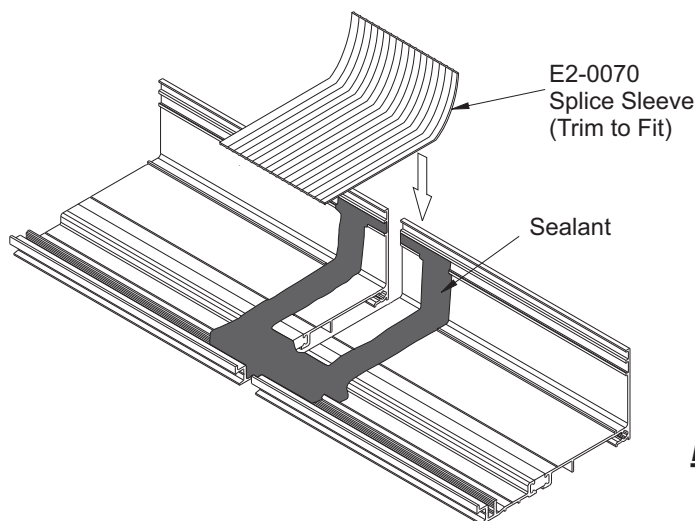

Detail 30

FRAME INSTALLATION

**STEP 10
INSTALL SILL FLASHING SPLICE SLEEVE (Continued)**

- Apply masking tape to the front of the sill flashing at the splice as shown in **Detail 31**.
- Thoroughly seal the small joint directly in front of the Silicone Splice Sleeve. Remove masking tape from the front gap after applying the sealant.

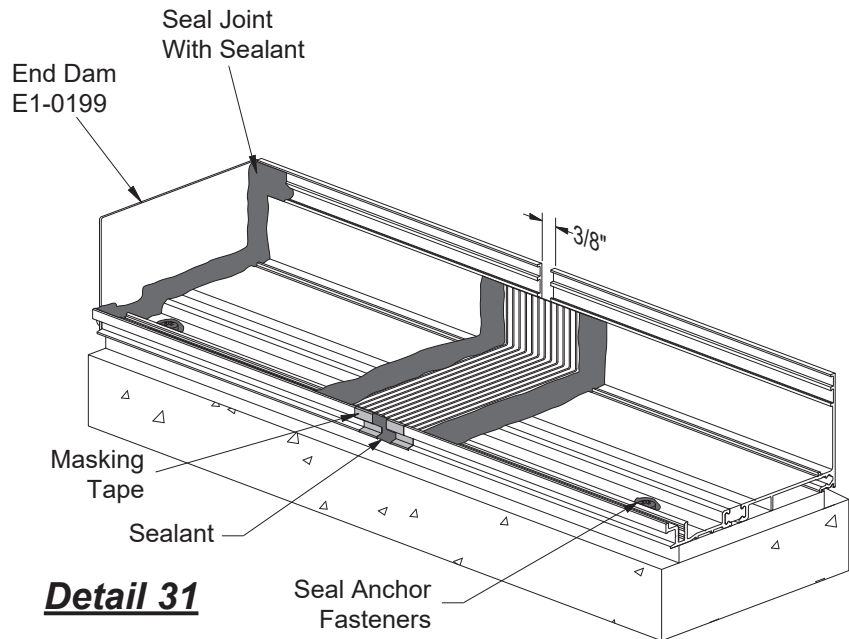

Detail 31

**STEP 11
SILL PREPARATION**

At every splice condition, apply bond breaker tape to the back of the sill member before the joint is sealed between the sill and sill flashing. See **Detail 32**.

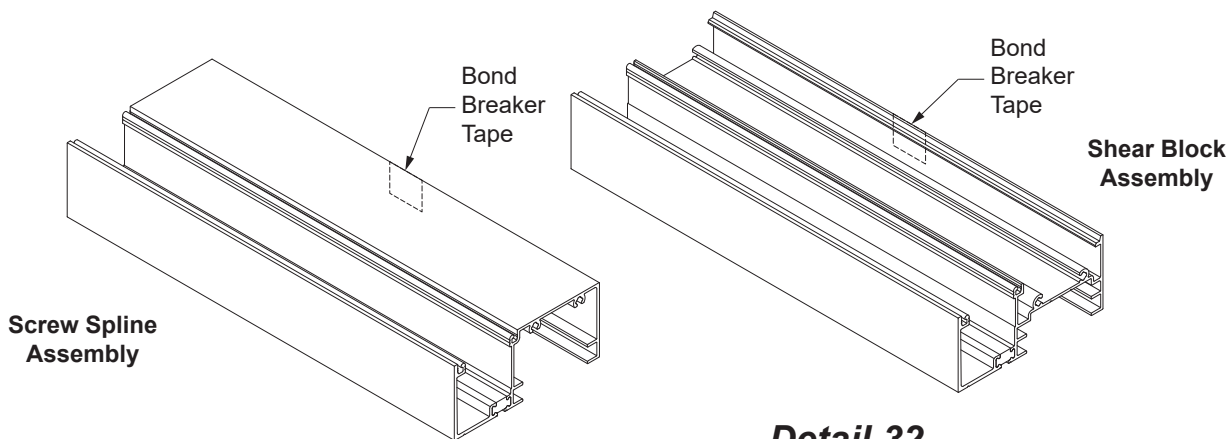

Detail 32

FRAME INSTALLATION

STEP 12 ATTACH HEAD RECEPTOR END CAPS

-Cut E2-0051 bulb gaskets to the same length as the head receptor and insert them into the reglet of both the BE9-2562 head receptor and E9-1033 snap cover. See **Detail 33**.

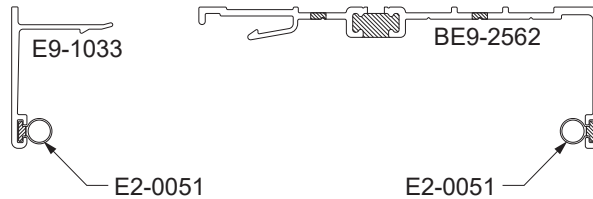

Detail 33

- Clean all joint surfaces using cleaner approved by sealant manufacturer.
- Apply sealant to the end of the head receptor as shown in **Detail 34**.
- Fasten the E1-2603 end caps to each jamb using two FC-1208 fasteners.
- Tool sealant to the inside of the end caps at the jambs similar to that for the sill flashing end dams (see **Detail 36**). Tape down the top corners to hold the end cap in place until the sealant cures.

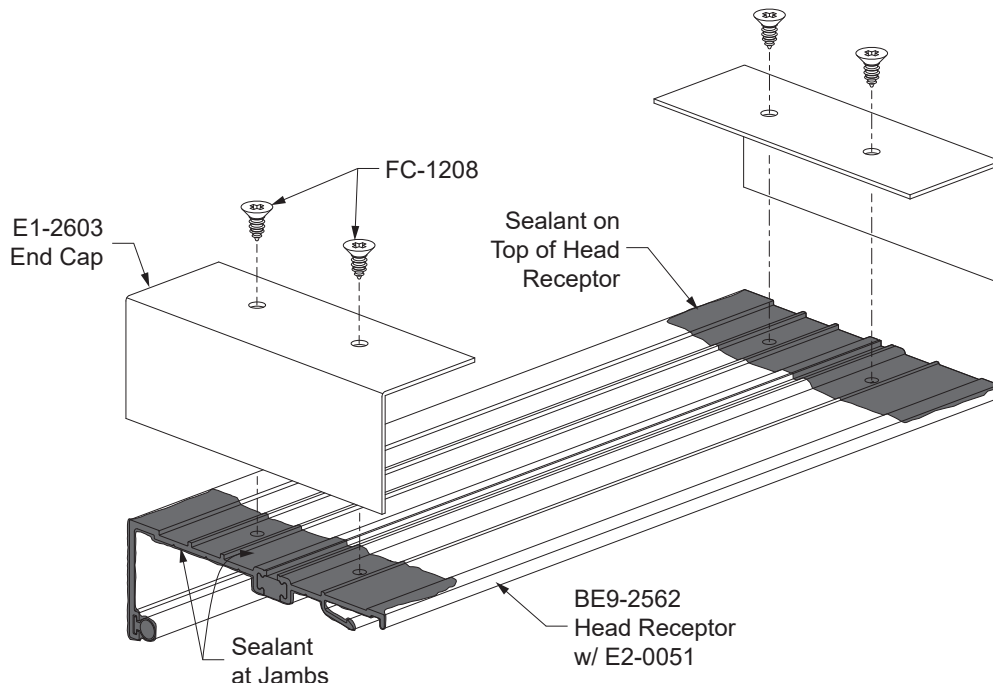

Detail 34

FRAME INSTALLATION

**STEP 12A
INSTALL HEAD RECEPTOR**

- Install the BE9-2562 head receptor to the substrate using fasteners per approved shop drawing or P.E. calculations. Allow for a 3/8" shim space to the substrate and a 3/8" gap at the splice joints.
- Seal all anchor fastener heads.
- Fill the gap at the exterior of the head receptor with sealant.

See **Details 35 & 36.**

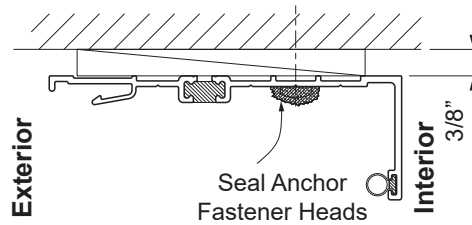

Detail 35

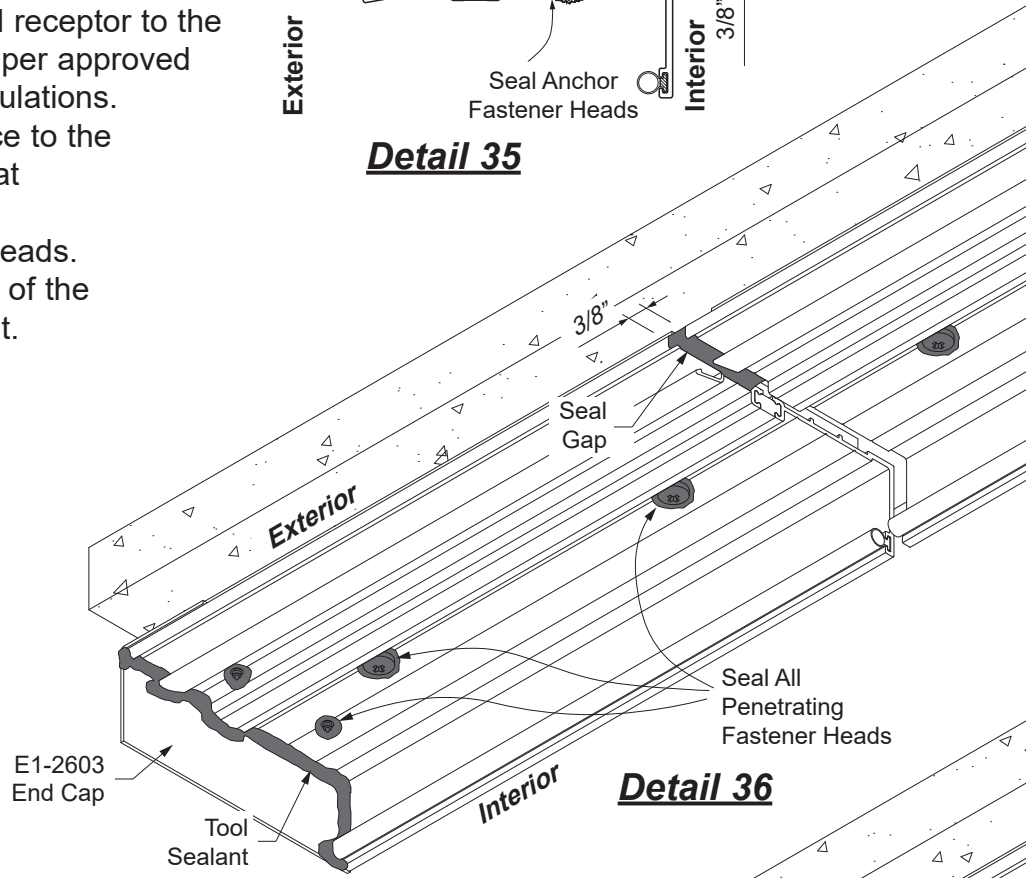

Detail 36

- Adhere an E2-0070 silicone sheet to the splice joints on a bed of sealant. Fill the gap at the back of the head receptor with sealant.

See **Detail 37.**

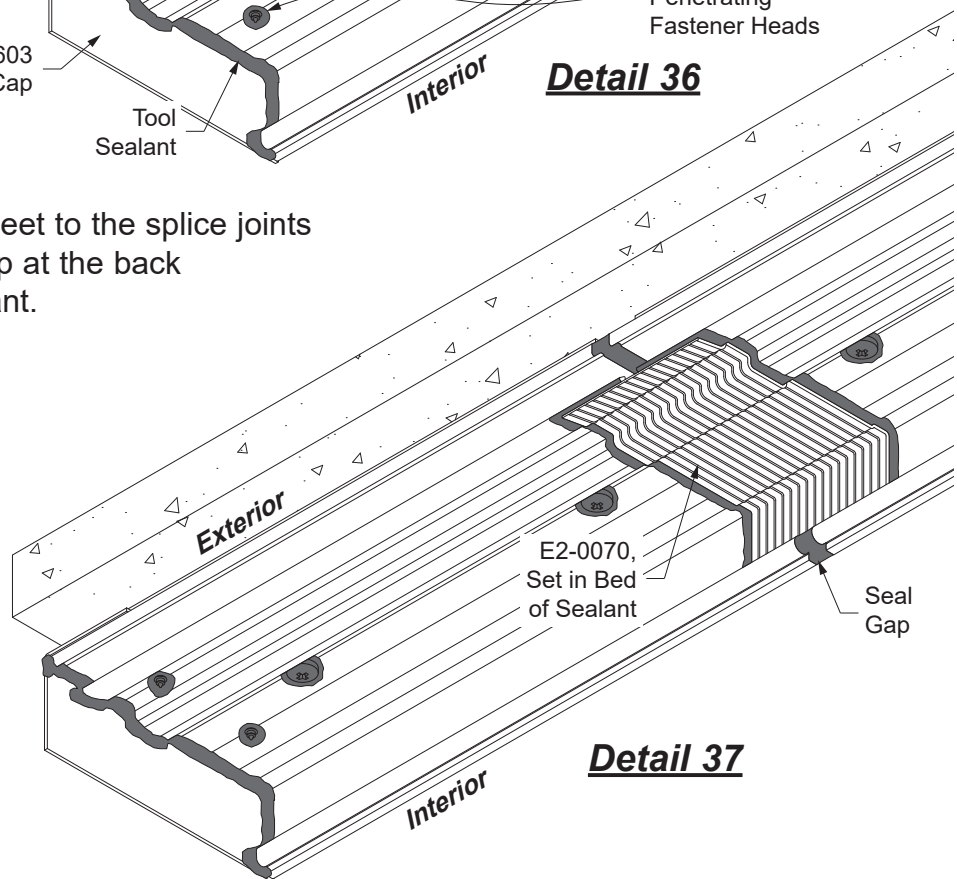

Detail 37

FRAME FABRICATION

STEP 13 FABRICATE SILL FLASHING FOR CORNERS

Install sill flashing at corners:

- Cut two 12" long pieces of sill flashing BE9-2578 and miter (45° for 90° corners and 67.5° for 135° corners).
- Align the two pieces at the corner condition with the mitered ends pushed together tight and anchor the sill flashing as called out on shop drawings.
- Apply and tool sealant to the mitered joint and anchor heads.

See **Detail 38**.

-Continue installing the rest of the sill flashing providing a 3/8" joint at splices as shown in **Step 10 on Page 25**.

* **Note:** Similar technique required for BE9-2562 head receptor.

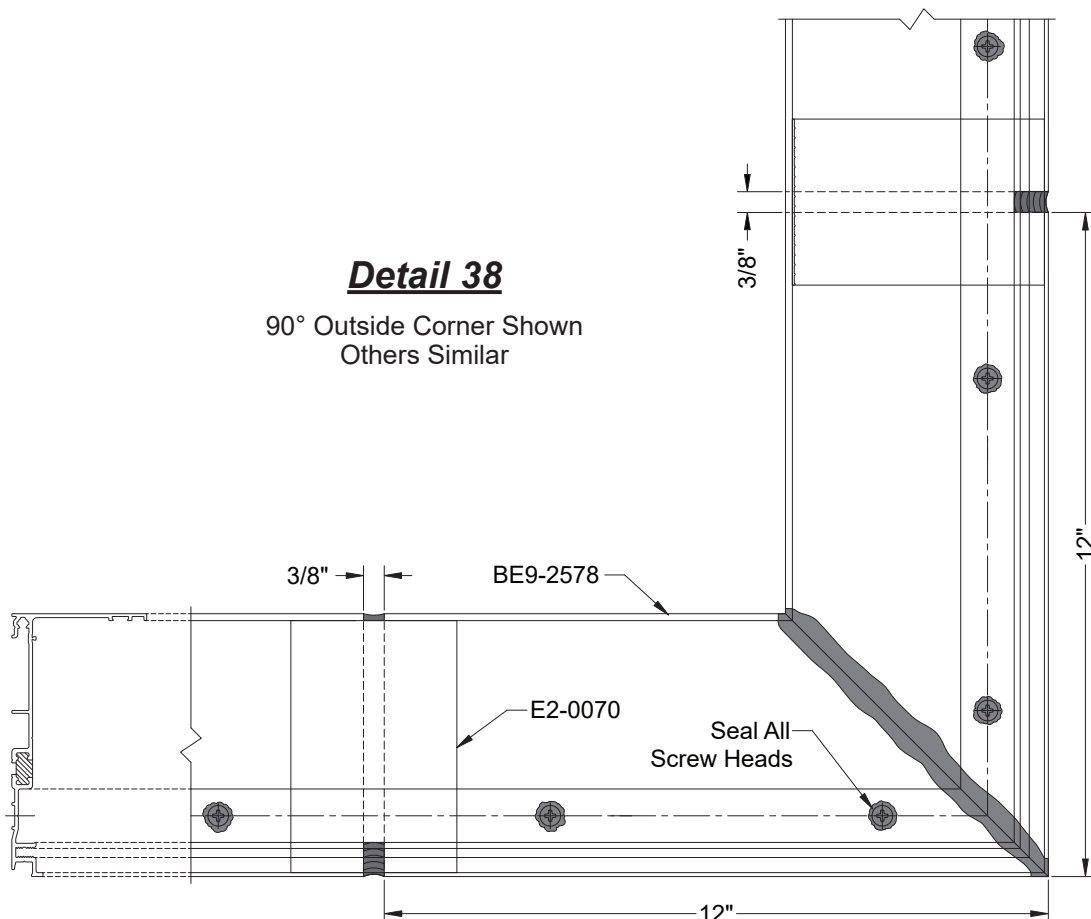

FRAME INSTALLATION

**STEP 14
INSTALL FRAMES**

-Apply sealant continuously to the front of the back leg of the sill flashing and immediately set the frame into the opening.

See **Detail 39**.

-Shim jamb and head members with a minimum of 3/8" shim.

-Anchor the frame to the structure at the head, and jamb: 3" from the ends and then 18" to 24" on center, or as required by P. E. calculations.

-Always install a shim at all anchor locations.

-Seal the jamb and head anchor fastener heads.

See **Detail 40**.

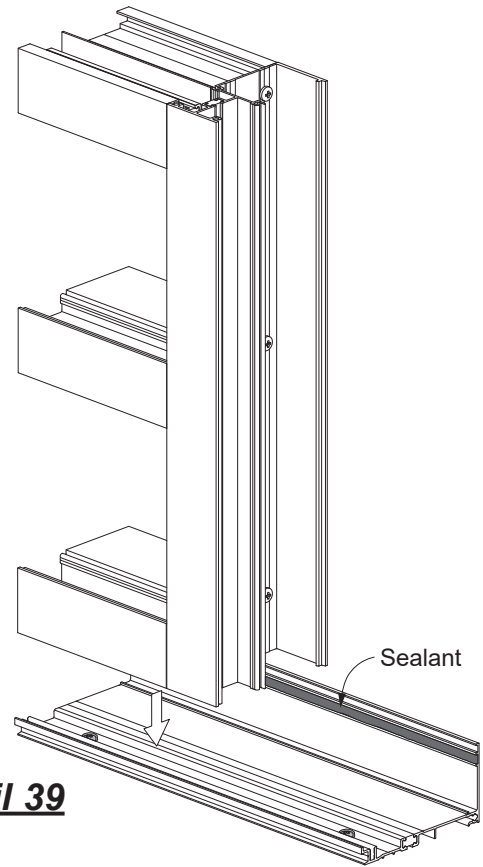

Detail 39

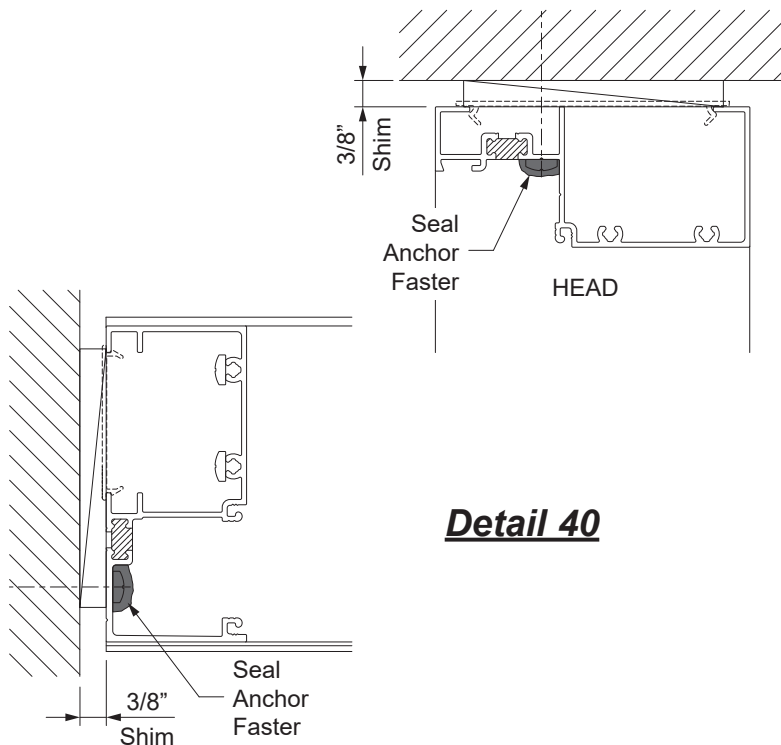

Detail 40

FRAME INSTALLATION

STEP 14 (Continued) INSTALL FRAMES

-For mullion end load reactions over 500 lbs., attach the sill to the sill flashing using PM-1006-SS screws.* Do not seal these screws.

-Also, add one (1) PM-1006-SS fastener 2" in both directions from the center line of the splice.

*To determine end load reactions, refer to approved shop drawings or P. E. stamped calculations.

See **Detail 41**.

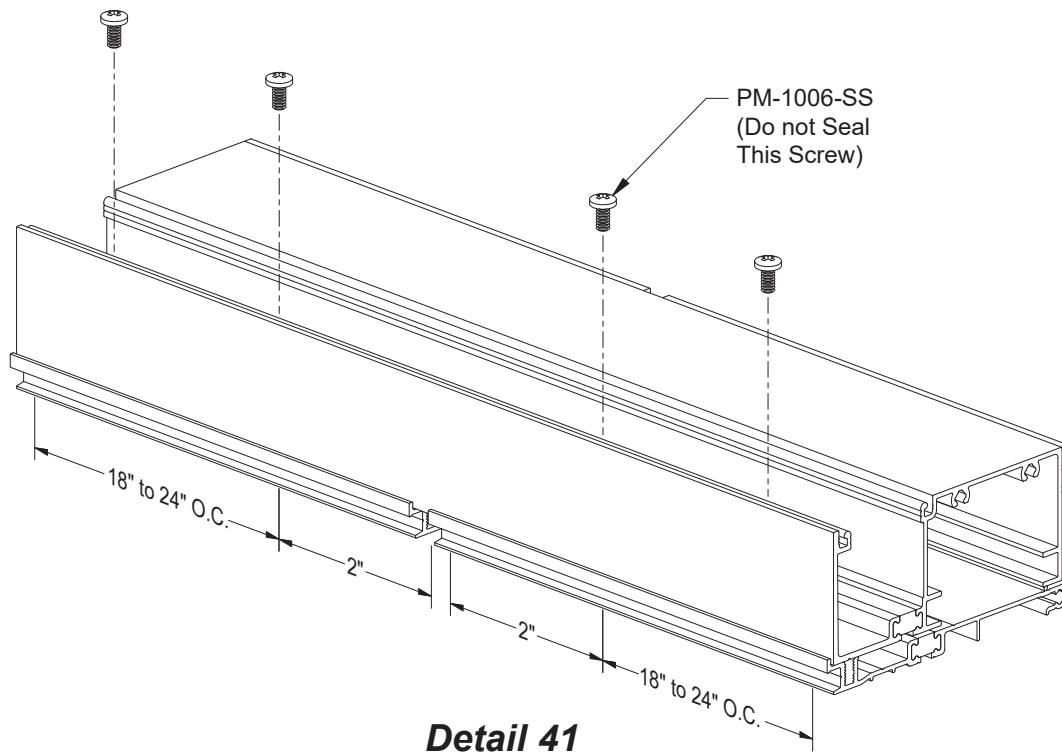

FRAME INSTALLATION

**STEP 14 (Continued)
INSTALL FRAMES W/ HEAD RECEPTOR**

- Rotate the assembled frames into position from the exterior, ensuring engagement into the sill flashing.
- Snap on the E9-1033 snap cover (with E2-0051 bulb gasket) into the head receptor.
- For mullion end load reactions over 500 lbs., attach the sill to the sill flashing using PM-1008-SS screws. Also add one (1) PM-1008-SS fastener 2" in both directions from the center line of the splice.

See **Detail 42**.

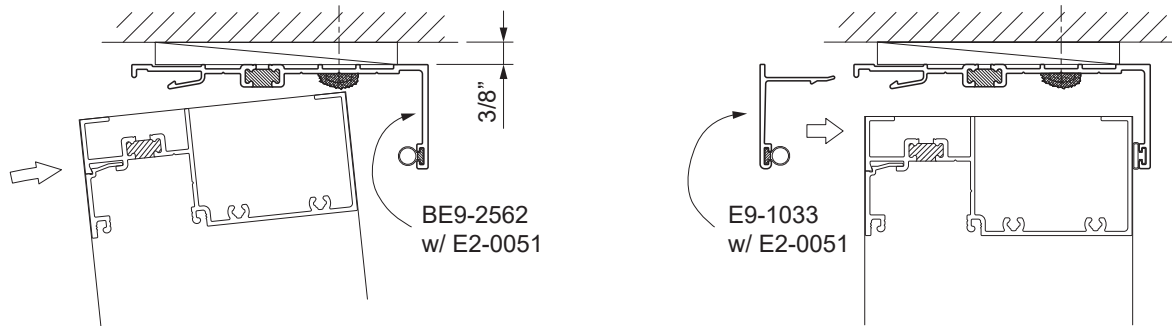

Detail 42

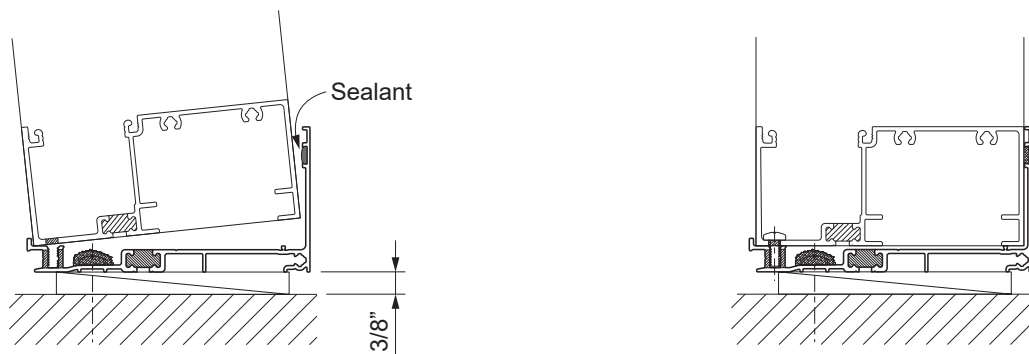

FRAME INSTALLATION

STEP 14 (Continued) INSTALL FRAMES

Inside Glazed Screw Spine Assembly:

- Apply sealant to the reglets at head, horizontal, and sill locations, filling the reglet as shown in **Detail 43**.
- Continue application of sealant to the front of the back leg of the sill flashing as each frame is installed.
- Snap assembled frames together if using screw spline assembly, and tool excess sealant.

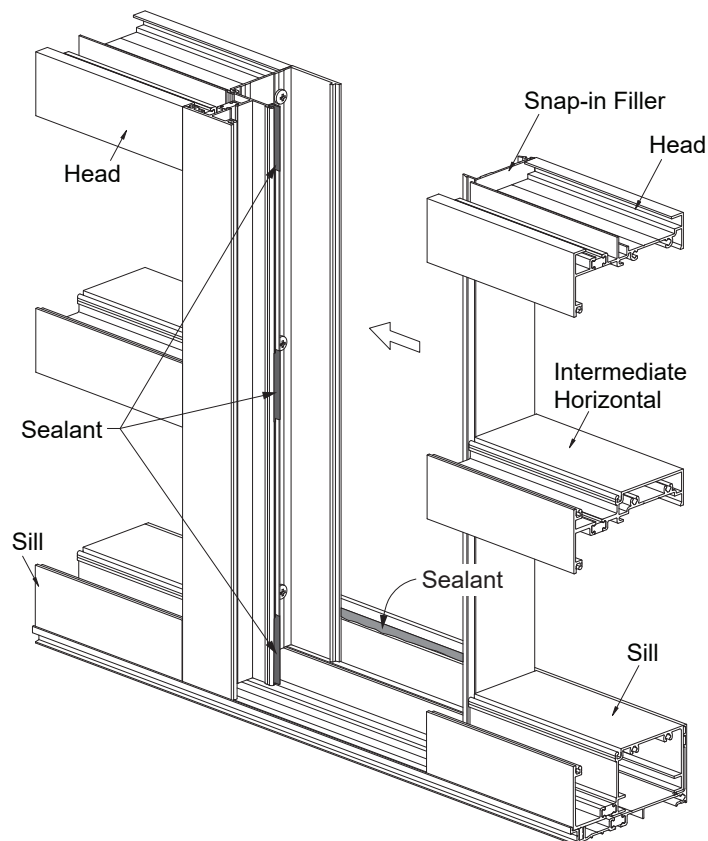

Detail 43

FRAME INSTALLATION**STEP 14 (Continued)
INSTALL FRAMES****Outside Glazed Screw Spine Assembly:**

- Apply sealant to the reglets at head, horizontal, and sill locations, filling the reglet as shown in **Detail 44**.
- Continue application of sealant to the front of the back leg of the sill flashing as each frame is installed.
- Snap assembled frames together if using screw spline assembly, and tool excess sealant.

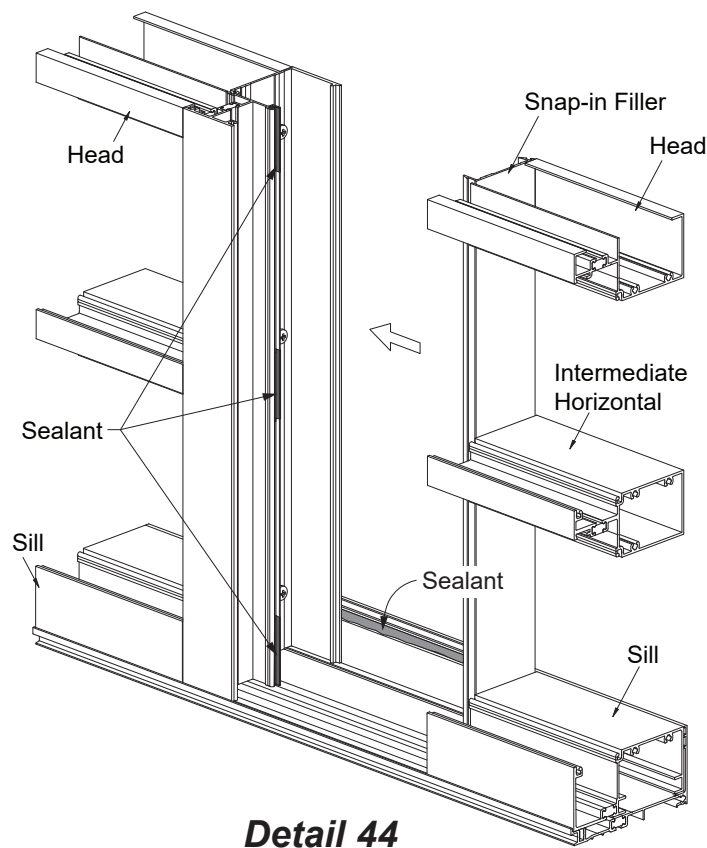

FRAME INSTALLATION

STEP 14 (Continued) INSTALL FRAMES

- Apply masking tape to the edges of sill flashing splice joint at the interior of the sill flashing.
- Apply and tool sealant to the gap in the interior running the full height of the sill flashing.
- Carefully remove tape before sealant skins over.

See **Detail 45**.

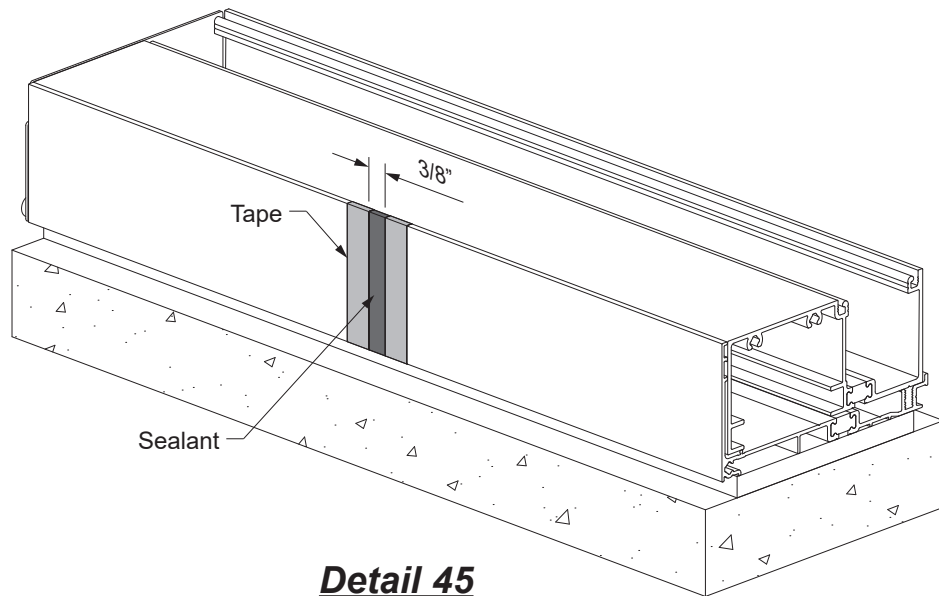

FRAME INSTALLATION

**STEP 14 (Continued)
INSTALL FRAMES**

Prior to snapping the assembled frames into the door jamb, the end of the sill flashing needs to be sealed to the door jamb.

- Apply and tool sealant to all sill flashing to door jamb joints.
- Apply sealant to completely fill the door jamb cavity and ramp the sealant down onto the sill flashing.

See **Detail 46**.

Refer to the **Entrances Installation Manual** for door installation instructions.

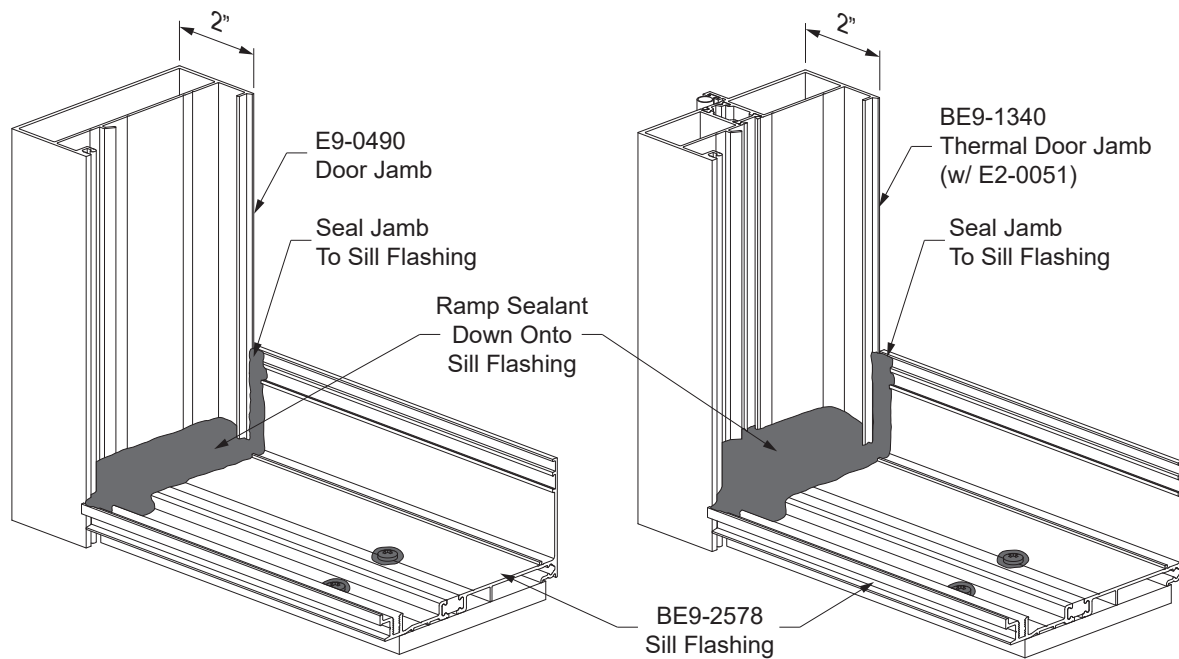

Detail 46

FRAME INSTALLATION

STEP 15 APPLY PERIMETER SEALANT

- Perimeter seal required at interior and exterior.
- Install backer rod around the perimeter of the frame.
- Apply sealant to the joint between the frame and the structure.
- Do not** block the weep holes with sealant.
- Make sure all screw and anchor heads are sealed.

See **Detail 47**.

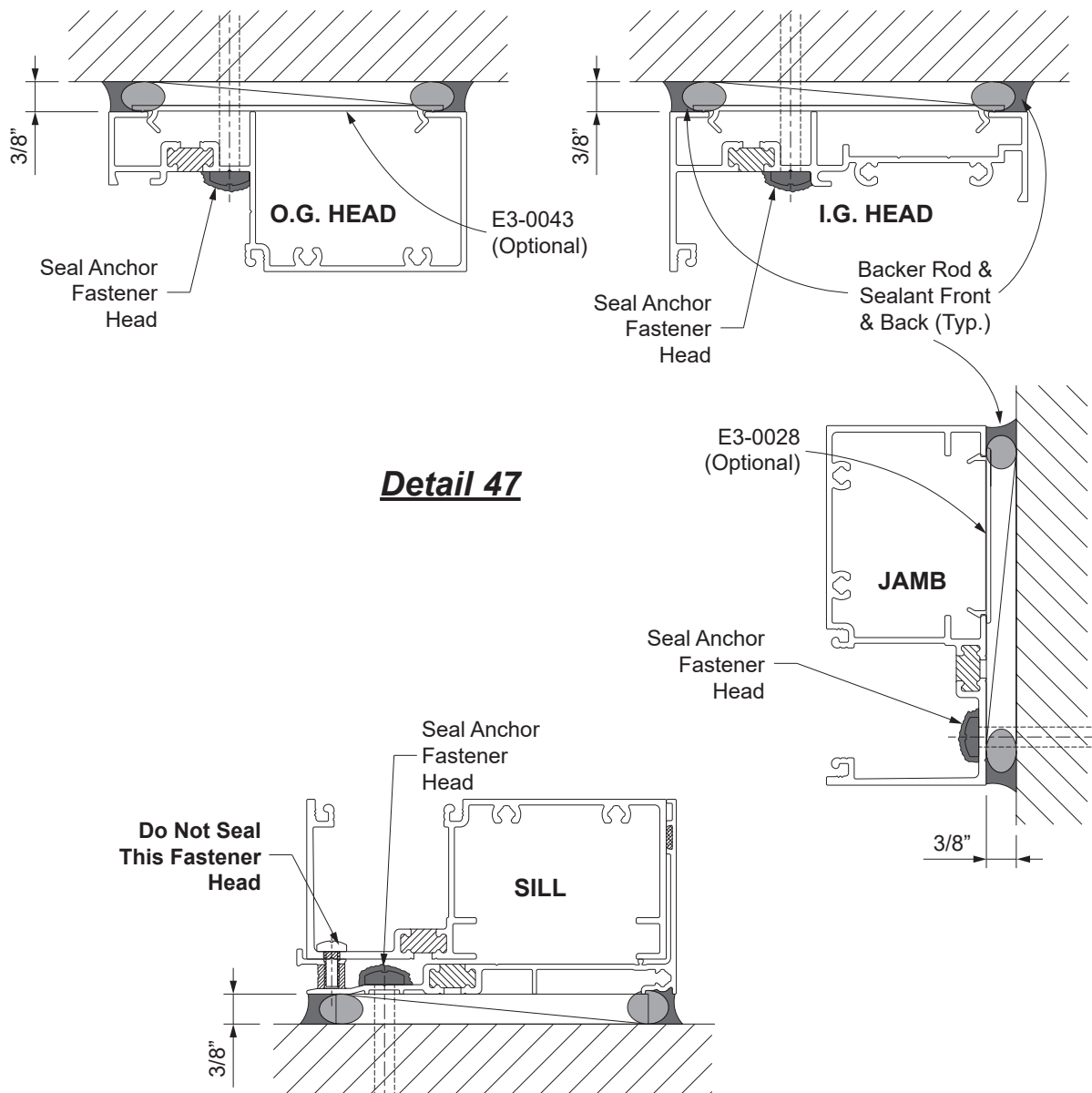

FRAME INSTALLATION

STEP 15A

APPLY PERIMETER SEALANT @ HEAD RECEPTOR

-Insert a 1" long piece of backer rod into the gap at the exterior head receptor snap cover between the head member and the head receptor.

See **Detail 48**.

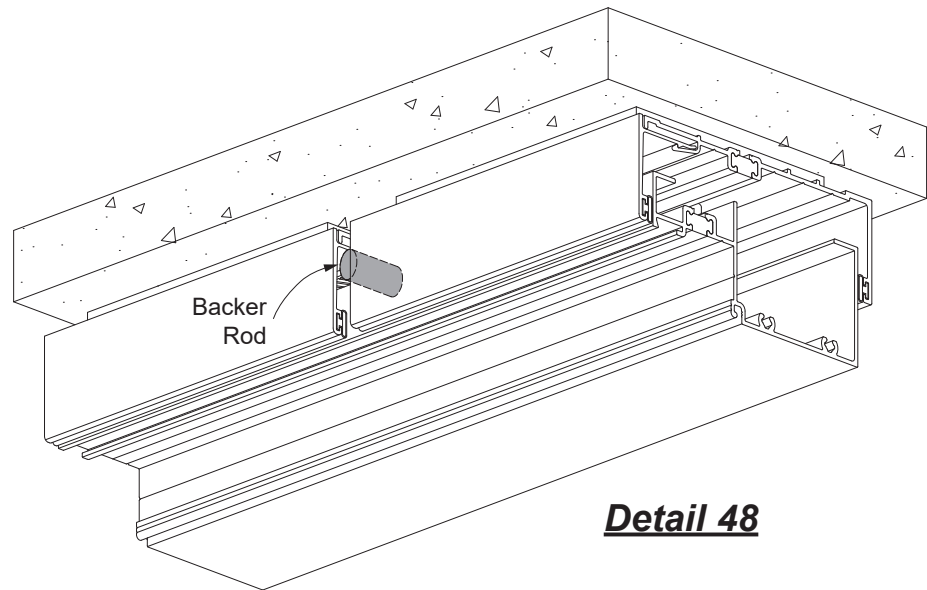

-Insert a continuous backer rod between the head receptor and substrate on both the interior and exterior of the frame.

-Apply and tool continuous sealant along the caulk joint and fill the gap at the exterior snap cover with sealant.

See **Detail 49**.

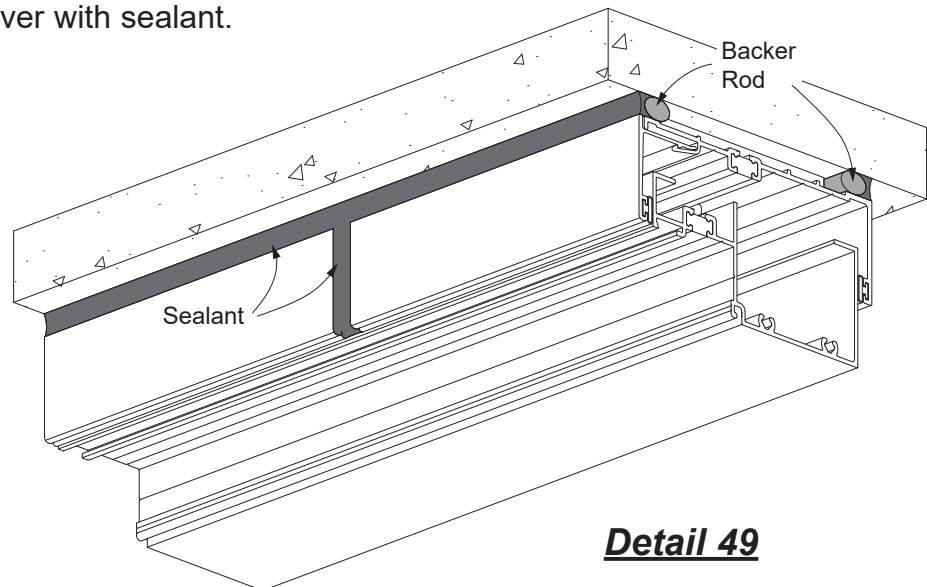

FRAME INSTALLATION

STEP 16 INSTALL WATER DEFLECTORS

YES 45 TU requires the installation of a water deflector, E2-0047, at the ends of every intermediate horizontal to keep water off of the insulating glass units.

-Peel away the protective paper from the bottom of the water deflector, E2-0047, and install the water deflector by rotating it over each end of the horizontal.

-Position the vertical leg of the water deflector against the end of the horizontal.

Note: For best adhesion, make sure that the horizontal is clean and dry.

See **Detail 50**.

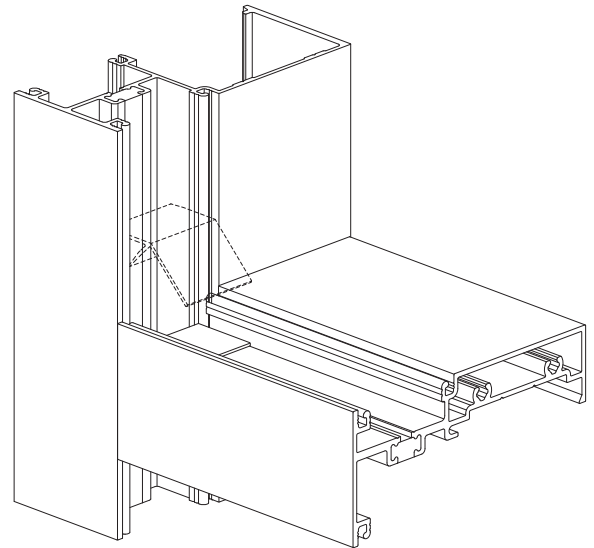

Detail 50
1" Glazing Shown

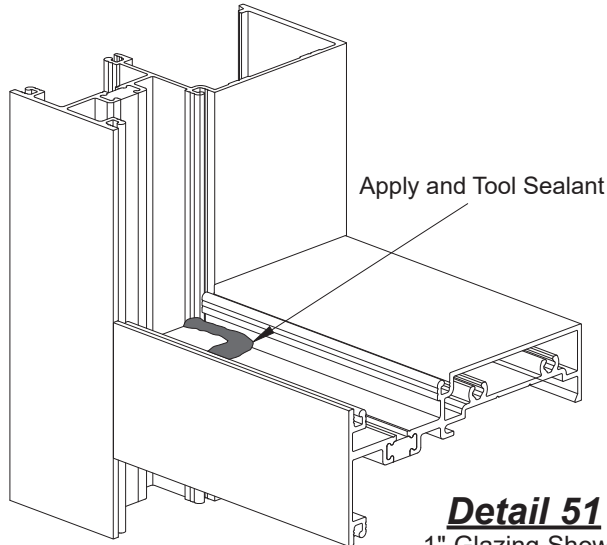

Detail 51
1" Glazing Shown

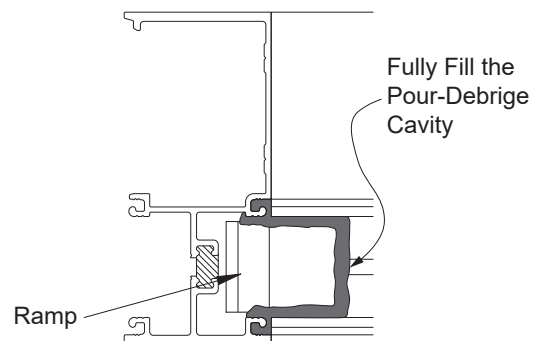

Detail 52
1" Glazing Shown

-Apply and tool sealant along the edges of the water deflector and down onto the horizontal.
See **Detail 51**.

-Seal the ramp of the water deflector to the sides of the vertical gasket reglets. Ensure the sealant fills the pour debridge cavity.
See **Detail 52**.

FRAME INSTALLATION**STEP 17****INSTALL HORIZONTAL FLUSH FILLERS (SHEAR BLOCK ASSEMBLY ONLY)**

-Snap in the E9-2512 flush filler into the horizontals and sill members as shown in **Detail 53**.

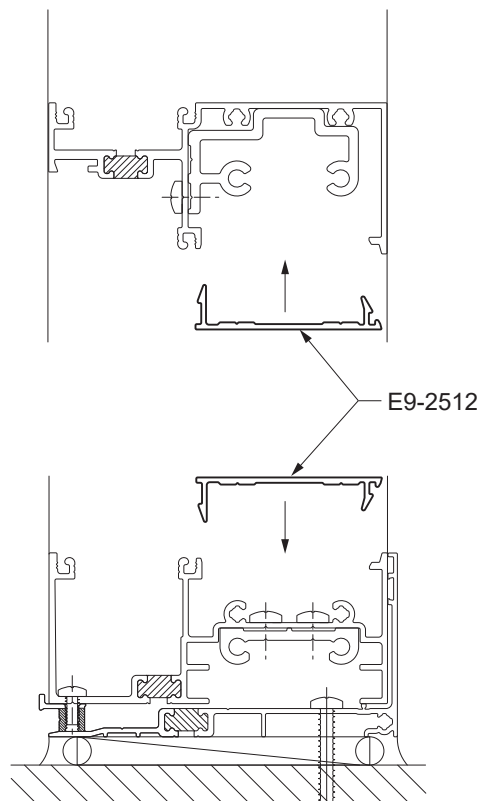
**Detail 53**

1" Glazing Shown

FRAME INSTALLATION

STEP 18

APPLY INTERNAL SEALANT

- Apply sealant to the vertical intersection of the horizontal and vertical members.
- Tool all of the sealant to ensure a water tight joint.
- Make sure all exposed screw heads are sealed.

See **Detail 54**.

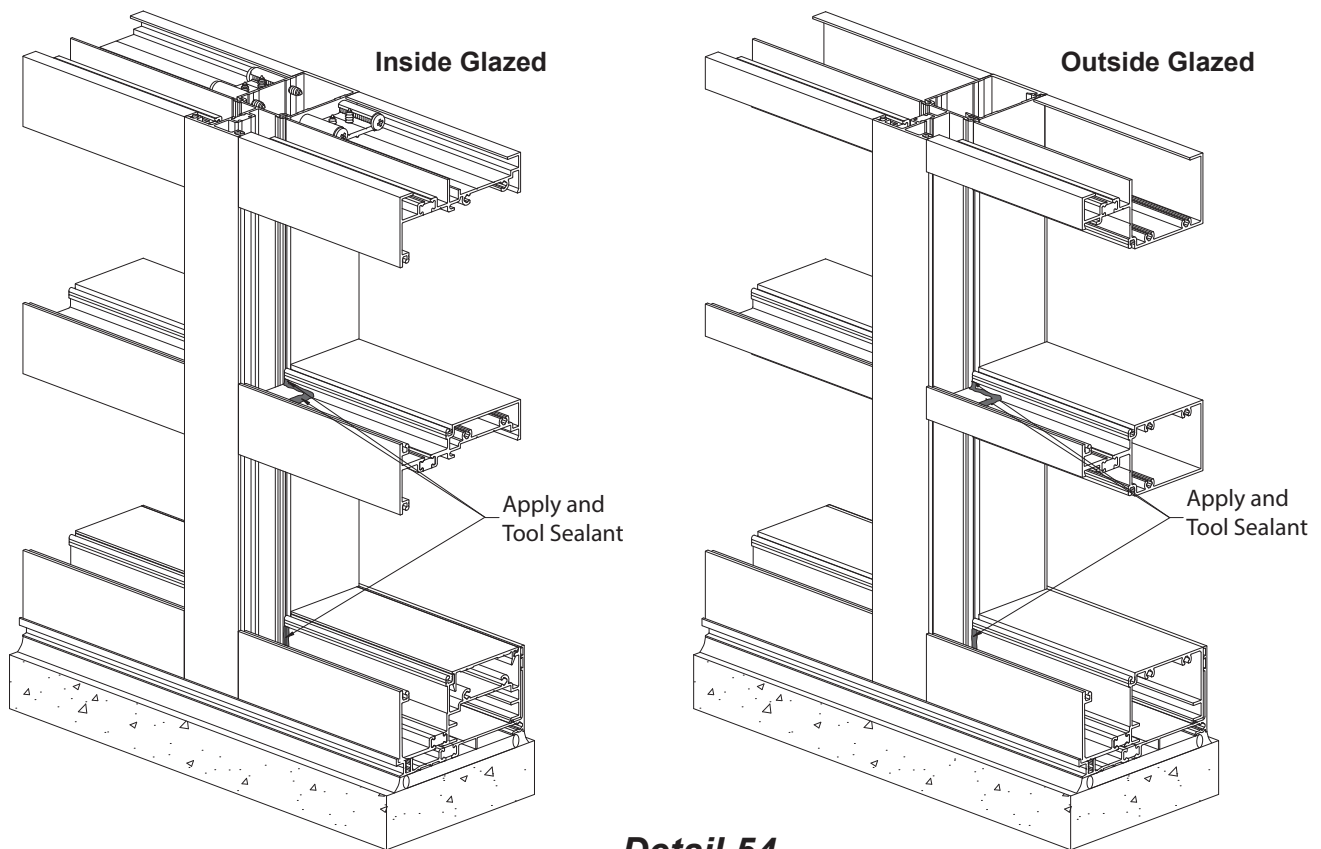

Detail 54

FRAME INSTALLATION

STEP 19 (Optional) INSTALL GLAZING ADAPTORS

Glazing adaptors, E9-1039 and E9-1040, allow for glazing infills other than the standard 1". Please refer to the glazing table below for possible adaptor/gasket combinations.

- Snap glazing adaptors into the interior gasket reglets of the verticals.
- Snap glazing adaptors into the interior gasket reglets of the horizontals.
- Apply and tool sealant to the joint between vertical and horizontal glazing adaptors.

See **Detail 55**.

Glazing Table - YES 45 TU

Glass Thickness	Adaptor	Exterior	Interior
3/16"	E9-1040	E2-0052	E2-0064
1/4"	E9-1040	E2-0052	E2-0052
5/16"	E9-1040	E2-0053	E2-0052
3/8"	E9-1040	E2-0053	E2-0053
1/2"	E9-1039	E2-0064	E2-0064
5/8"	E9-1039	E2-0052	E2-0052
3/4"	E9-1039	E2-0053	E2-0053
7/8"	—	E2-0064	E2-0064
1"	—	E2-0052	E2-0052

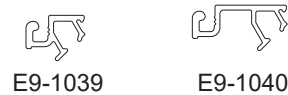

Seal Corners of
Glazing Adaptors

Detail 55

Outside Glazed Shear Block Assembly Shown, others similar.

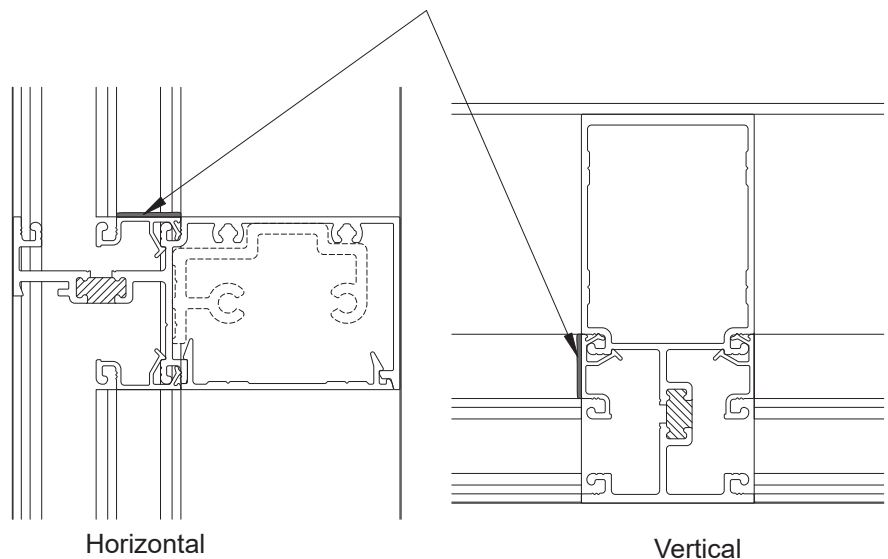

GLAZING

STEP 20

INSTALL INTERIOR GLAZING GASKETS (Outside Glazing Shown, Inside Glazing Similar)

The interior glazing gaskets must be installed prior to the glazing process.

-Using a small brush clean out any dirt that may have accumulated in the gasket reglets.

Vertical glazing gaskets must be installed first:

- Cut vertical glazing gaskets to Daylight Opening plus(+) 1/4" for each foot of length.
- Insert the gasket into the reglet at each end first, and then insert the gasket at the midpoint of the opening.
- Push the gasket into the reglet starting at the midpoint and work towards each end.

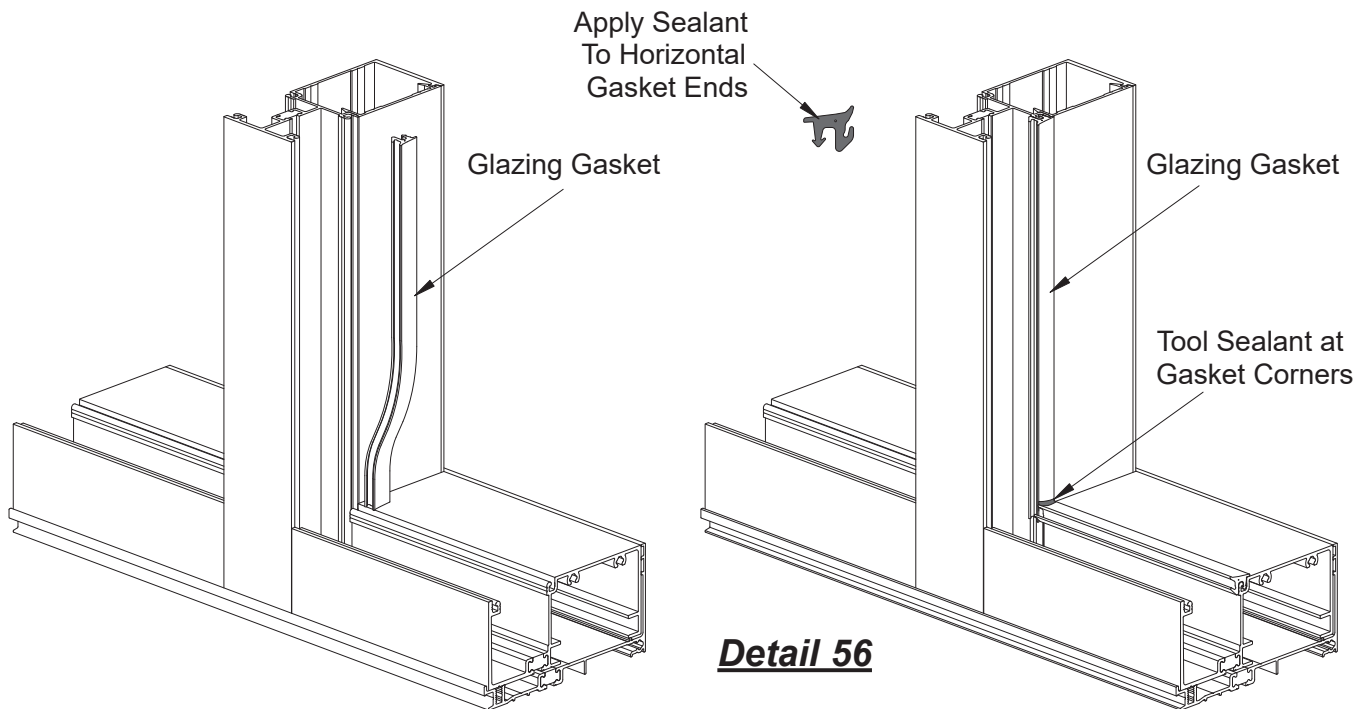

Install horizontal glazing gaskets next:

- Cut horizontal glazing gaskets to Daylight Opening plus(+) 1/4" for each foot of length.
- Apply sealant to each end of the horizontal glazing gasket prior to inserting into the reglet.
- Insert the gasket into the reglet at each end first and push each end tight against the vertical gasket.
- Then insert the gasket at the midpoint of the opening and push the gasket into the reglet starting at the midpoint and work towards each end.
- Tool the excess sealant at the gasket corners to ensure a watertight seal.

See **Detail 56**.

GLAZING

STEP 21

INSTALL GLASS (Outside Glazing Shown, Inside Glazing Similar)

Determine the glass size:

Horizontal Glass Size = D.L.O. plus(+) 3/4"
Vertical Glass Size = D.L.O. plus(+) 3/4"

- Install E2-0166 side block into the shallow pocket.
- Carefully install the glass into the opening: insert the leading edge of the lite up and into the deep pocket first and then rotate the trailing edge in place.
- Carefully lift lite of glass, install setting blocks at quarter points of horizontal D.L.O. or according to engineering calculations.
- Make sure the glass is properly positioned on all setting blocks.

See **Detail 57**.

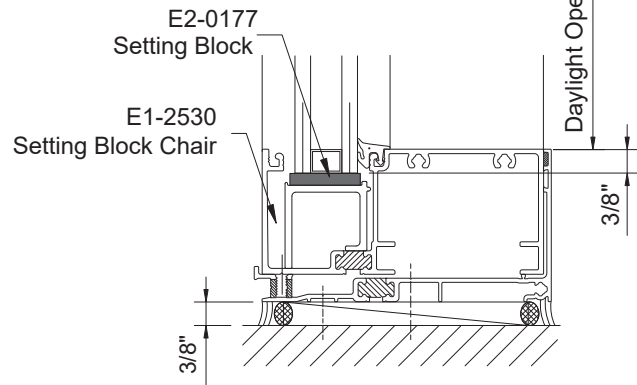
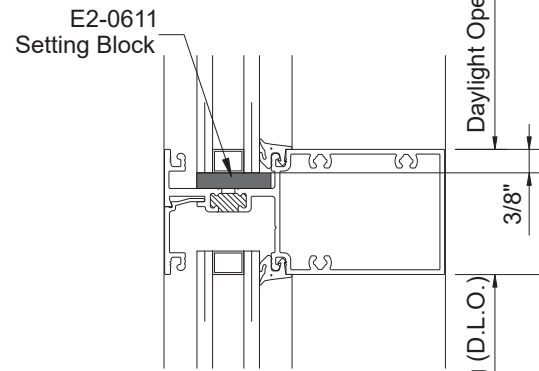
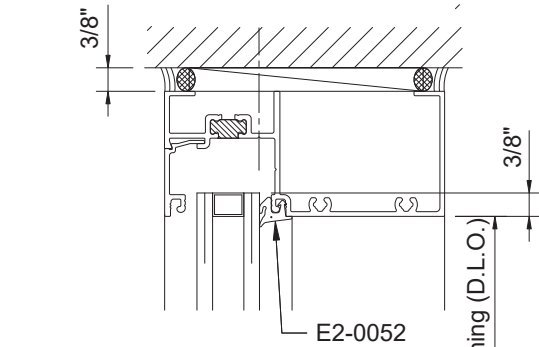

Detail 57
 Outside Glazed Shown
 Inside Glazed Similar

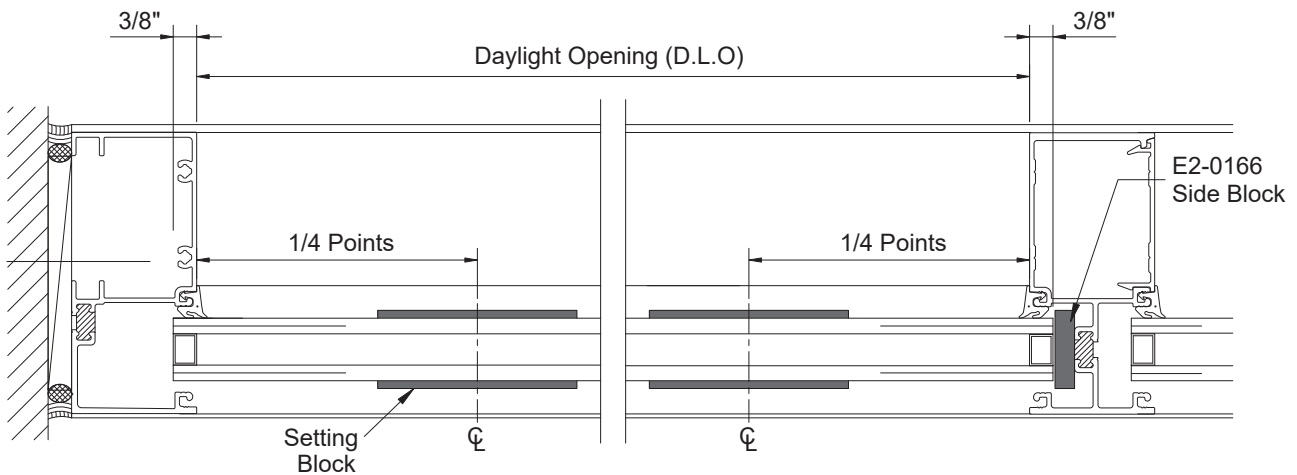

GLAZING

STEP 22 INSTALL ANTI-WALK BLOCKS

YES 45 TU frames require the installation of an anti-walk block E2-0154, in the mullion deep glazing pocket of each lite centered on the daylight opening, and anti-walk block E2-0545 in glazing pocket at jamb conditions.

-Flatten the anti-walk block against the exterior surface of the glass and push it into the opening between the glass and the mullion until it is released into the glazing pocket.

See **Detail 58**.

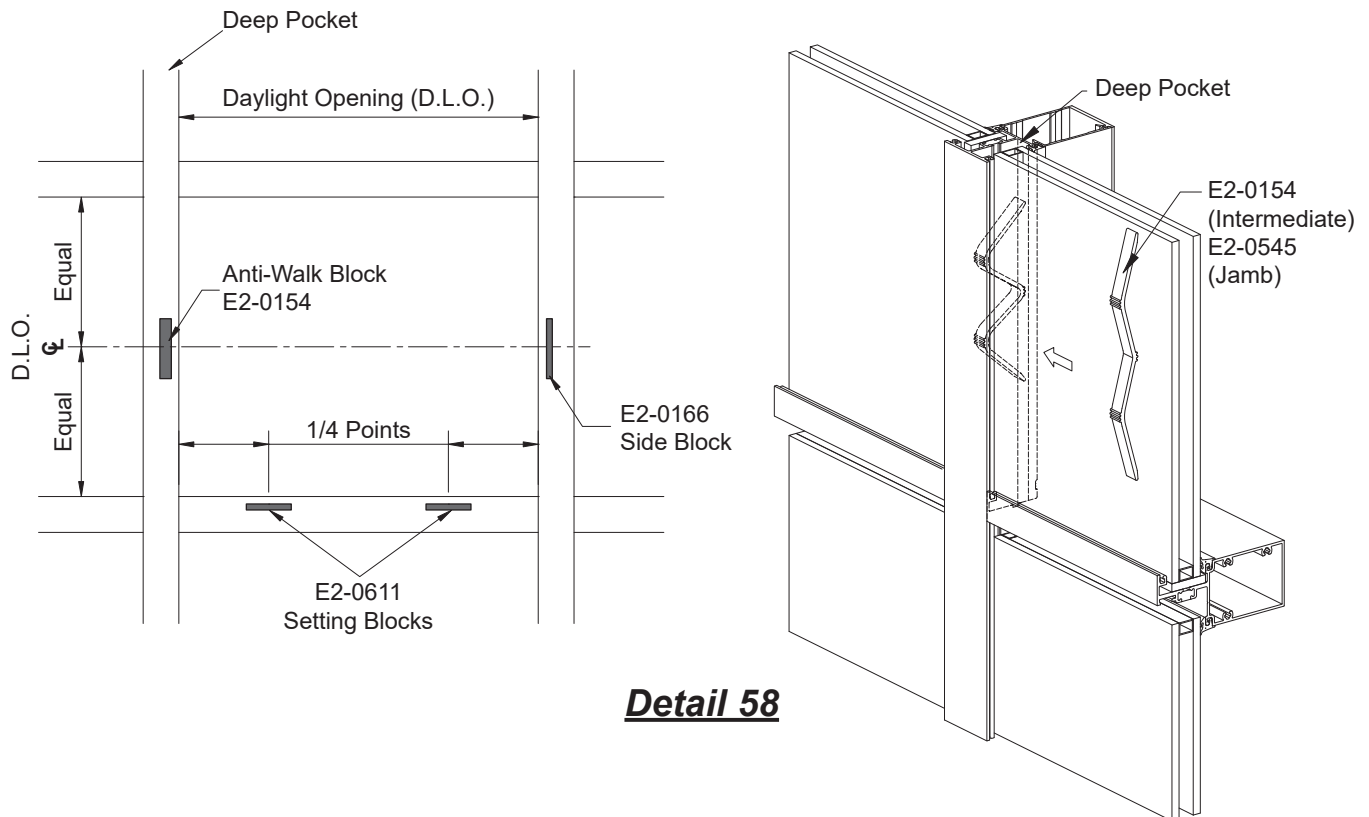

Detail 58

GLAZING

STEP 23 INSTALL INTERIOR GLASS STOPS & GLAZING GASKETS (INSIDE GLAZING)

-Apply sealant to the ends of the interior glass stops as shown in **Detail 59**.

-Snap the interior glass stops into place. Wipe off excess sealant.

-Install the interior glazing gaskets using the same technique described in **Step 20** on **Page 45**. Always install the vertical glazing gasket first.

Repeat **Steps 21 through 23** until all lites are installed.

Detail 59

1" Glazing Shown
1/4" Glazing Similar

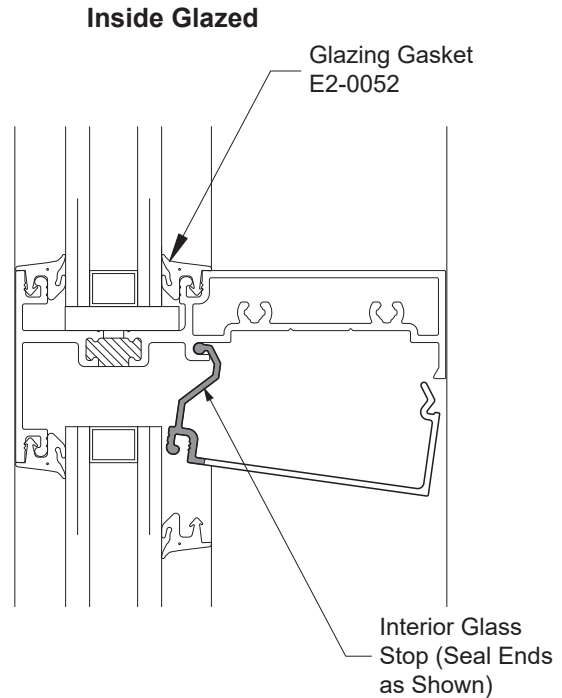

STEP 23A INSTALL EXTERIOR GLASS STOPS & GLAZING GASKETS (OUTSIDE GLAZING)

-Snap the exterior glass stops into place as shown in **Detail 59A**.

-Install the exterior glazing gaskets using the same technique described in **Step 20** on **Page 45**. Always install the vertical glazing gasket first.

Repeat **Steps 21 through 23A** until all lites are installed.

Detail 59A

1" Glazing Shown
1/4" Glazing Similar

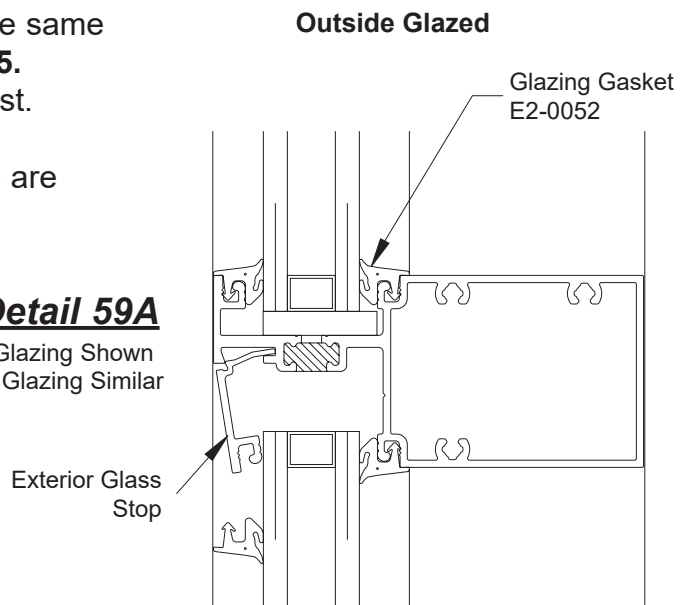



101 Marietta Street NW
Suite 2100
Atlanta, Georgia 30303
www.ykkap.com