

YES 60 FI/TU Storefront System

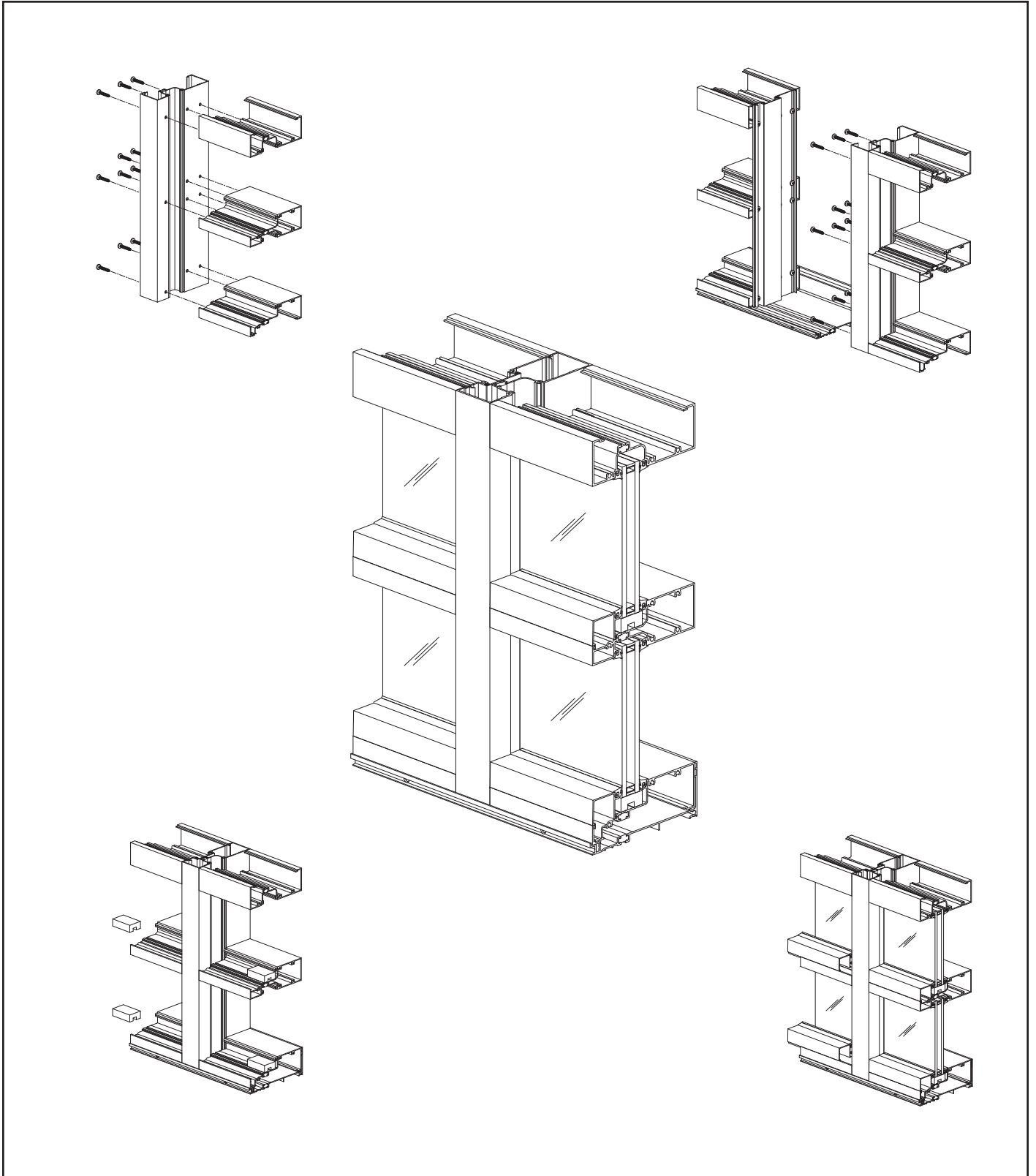

Installation Manual





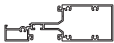





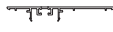

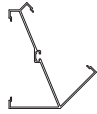









TABLE OF CONTENTS

Installation Notes	Page ii
PARTS DESCRIPTION	
YES 60 FI Framing Members	Page 1
YES 60 TU Framing Members	Page 2
YES 60 FI/TU Door Framing Members	Page 3
YES 60 FI/TU Accessories	Pages 3 & 4
FRAME FABRICATION	
Determine Frame Size	Page 5 & 6
Fabricate Two Piece Mullions for Screw Spline Assembly	Page 7
Fabricate Head, Horizontal & Sill Members	Page 8
Fabricate Glass Stops & Glazing Adaptors	Page 8
Fabricate Sill Members	Page 9
Fabricate Sill Flashing	Pages 9 to 11
Fabricate Head Receptor	Page 11
FRAME ASSEMBLY	
Assemble Frames For Screw Spline Assembly	Page 12
Install Foam Plugs at Head	Page 13
FRAME INSTALLATION	
Install Sill Flashing End Dams	Page 14
Install Sill Flashing	Page 15
Install Sill Flashing Splice Sleeve	Pages 15 & 16
Sill Preparation	Page 16
Attach Head Receptor End Caps	Page 17
Install Head Receptor	Page 18
Install Sill Flashing for Corners	Page 19
Prepare Door Jambs	Page 20
Install Frames	Pages 21 & 22
Install Expansion Mullions Where Required	Page 23
Install Corner Corner Assemblies	Page 24 & 25
Install Optional Compound Vertical Mullions	Pages 26 & 27
Apply Perimeter Sealant	Page 28 & 29
Install Water Deflectors	Page 30
Apply Internal Sealant	Page 31
Install Glazing Adaptors	Page 31
Install Optional Compound Horizontals	Pages 32 to 34
GLAZING	
Install Interior Glazing Gaskets	Page 35
Install Glass	Page 36
Install Anti-Walk Blocks	Page 37
Install Exterior Glass Stops & Gaskets	Page 37

Installation Notes

























1. Do not drop, roll or drag boxes of aluminum framing. Move and stack boxes with proper support to prevent distortion. If fork lifts are used be especially careful about striking the boxes when lifting or moving.
2. Store in a dry, out of the way area. If rain exposure, condensation or any water contact is likely, then all packaging material should be removed. Wet packaging materials will discolor and may stain aluminum finishes and paints.
3. All materials should be checked for quality and quantity upon receipt, YKK AP must be notified immediately of any discrepancies in shipment. Check to make sure that you have the required shims, sealants, supplies and tools necessary for the installation.
4. Carefully check the openings and surrounding conditions that will receive your material. Remember, if the construction is not per the construction documents, it is your responsibility to notify the general contractor in writing. Any discrepancies must be brought to the general contractor's attention before you proceed with the installation.
5. Gather your shop drawings, materials, packing list, and this installation manual. Carefully review parts location, the sequence it goes therein, when you glaze it and how you seal it. Installation instructions are of a general nature and may not cover every condition you will encounter. The shop drawings and/or installation manuals were prepared specifically for the product.
6. Any material substitutions must be of equal or greater quality.
7. Make certain that material samples have been sent for compatibility testing for all manufacturer's sealants involved. Make certain sealants have been installed in strict accordance with the manufacturer's recommendations and specifications.
8. Remember to isolate, in an approved manner, all aluminum from uncured masonry or other incompatible materials.
9. System-to-structure fasteners are not supplied by YKK AP. Fasteners called out on shop drawings are to indicate minimum sizes for design loading.
10. Entrances are to be installed plumb, square, level, and true.
11. If any questions arise concerning YKK AP products or their installation, contact YKK AP for clarification before proceeding.
12. YKK AP storefront and/or curtain wall framing is typically completed before drywall, flooring and other products which may still be in process. Take the extra time to wrap and protect the work produced.
13. Cutting tolerances are plus zero (0"), minus one thirty second (-1/32") unless otherwise noted.
14. Check our website, www.ykkap.com, for the latest installation manual update prior to commencing work.

YES 60 FI FRAMING MEMBERS (2" x 6")

	Mullion 2" x 6"	E9-2911		Head Receptor Stop	E9-1033
	Head / Jamb	E9-2904		Expansion Mullion (Female)	Y7-9969
	Horizontal	E9-2903		Expansion Mullion (Male)	Y7-9970
	Horizontal / Sill	E9-2902		90° Corner Cover (Male)	E9-2938
	Glass Stop	E9-1015		90° Corner Cover (Female)	E9-2939
	Flat Filler	E9-2905		Adaptor for High Sill Cover	E9-2937
	Sill Flashing	E9-2901		135° Corner Mullion	E9-2940
	Heavy Duty Mullion 2" x 6"	E9-2906		Glazing Adaptor For 1/2", 5/8" & 3/4" glazing	E9-1039
	Heavy Duty Mullion 2-1/4" x 6"	E9-2943		Glazing Adaptor For 3/16", 1/4", 5/16", & 3/8" glazing	E9-1040
	Pocket Filler	E9-2907		Flush Pocket Filler	E9-1020
	Deep Pocket Filler	E9-2934		2-1/2" x 3/4" Face Cover * For Custom Mullions and Horizontals	E9-1206
	Head Receptor	E9-7361		5" x 3/4" Face Cover * For Custom Mullions and Horizontals	E9-3542







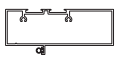

* Other sizes available. Contact YKK AP for more information.

YES 60 TU FRAMING MEMBERS (2" x 6")



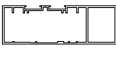

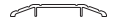
	Mullion 2" x 6"	BE9-2911		Head Receptor Stop	E9-1033
	Head / Jamb	BE9-2904		Expansion Mullion (Female)	BY7-9969
	Horizontal	BE9-2903		Expansion Mullion (Male)	BY7-9970
	Horizontal / Sill	BE9-2902		90° Corner Cover (Male)	E9-2938
	Glass Stop	E9-1015		90° Corner Cover (Female)	E9-2939
	Flat Filler	BE9-2905		Adaptor for High Sill Cover	BE9-2937
	Sill Flashing	BE9-2913		135° Corner Mullion	BE9-2940
	Pocket Filler	BE9-2910		Glazing Adaptor For 1/2", 5/8" & 3/4" glazing	E9-1039
	Deep Pocket Filler	BE9-2912		Glazing Adaptor For 3/16", 1/4", 5/16", & 3/8" glazing	E9-1040
	Heavy Duty Mullion 2" x 6"	BE9-2906		Pocket Filler	BE9-2570
	Heavy Duty Mullion 2-1/4" x 6"	BE9-2943		2-1/2" x 3/4" Face Cover * For Custom Mullions and Horizontals	E9-1206
	Head Receptor	BE9-7361		5" x 3/4" Face Cover * For Custom Mullions and Horizontals	E9-3542

* Other sizes available. Contact YKK AP for more information.

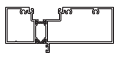
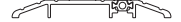

YES 60 FI/TU DOOR FRAMING MEMBERS (2" x 6")

	6" x 2" Door Head O/P	AS-9480		Door Stop Base Used with AS-0409	E9-1113
	6" Door Jamb	AS-9562		Transom Glass Stop For 1" glazing	E9-0413
	6" x 2" Door Head OHCC	E9-2945		Transom Glazing Pocket For 1" glazing	E9-0435
	Door Stop For OHCC	AS-0215		Threshold 1/2" x 4"	E9-0407
	Door Stop O/P Assembly E9-0409 and E2-0051	AS-0409			





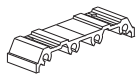
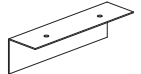

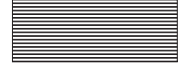





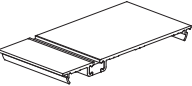

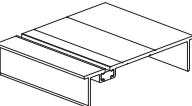

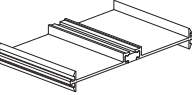

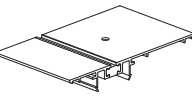

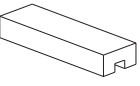

YES 60 TU THERMAL DOOR FRAMING MEMBERS (2" x 6")

	6" Door Jamb O/P For 25T/35T/50T E2-0051 Gasket Not included	BE9-2950		Transom Glass Stop For 1" Glazing Used with BE9-2583	E9-1592
	6" x 2" Door Head O/P For 25T/35T/50T E2-0051 Gasket Not included	BE9-2951		Threshold 1/2" x 4-1/2" For 25T/35T/50T	BE9-0465
	Transom Glazing Pocket For 25T/35T/50T Used with E9-1592	BE9-2583			

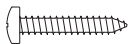
ACCESSORIES

	Shear Block For Transom Bar E9-2945	E1-0317		End Cap For Head Receptors E9-7361 & BE9-7361	E1-2908
	End Dam For Sill Flashing BE9-2913	E1-9989		Splice Sleeve For Sill Flashing E9-2901 & BE9-2913 and Head Receptor E9/BE9-7361	E2-0070

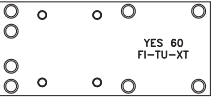
ACCESSORIES (Continued)

 PVC Flat Filler 12'-0" Long	E3-9905		Elastomer Weathering For Head Receptor	E2-0051
 Flat Filler Use at all anchor locations	E1-2903		Weathering Gasket For Expansion Mullion	K2-2441
 Optional Head Anchor 4" Long	E1-2905		Foam Backer Tape 1" x 1-1/4" (Roll)	E2-0259
 Mullion Clip 3" Long	E1-2906		#10 x 3/4" FHSMS Type AB, Zinc Plated Steel For Attachment of Horizontal to Shear Block E1-0317	FC-1012
 Sidelite Base Clip For compound horizontals, 3" Long	E1-2907		#12 x 1/2" FHSMS Type AB , Zinc Plated Steel For Attachment of End Cap E1-2908 to Receptor	FC-1208
 Setting Block For outside glazed Horizontal & sill	E2-0020		#10-24 x 1/2" PHMS Stainless Steel For Attachment of Sill to Sill Flashing	PM-1008-SS
 Water Deflector	E2-0047		#12 x 3/4" UFHSMS Type A Zinc Plated Steel For End Dam Attachment	UA-1212
 "W" Side Block For Deep Pocket	E2-0153		#12 x 1" PHSMS Type AB, Zinc Plated Steel For Screw Spline Attachment	PC-1216
 Pile Weathering Seal	E2-0062		#12 x 1-1/4" PHSMS Type AB, Zinc Plated Steel, For Screw Spline Attachment When Using BE9-2904 as Vertical	PC-1220
 Glazing Gasket 3/16" F.C.	E2-0052		#12 x 1-1/4" PHSMS Type AB, Zinc Plated Steel For Attachment of Shear Block E1-0317 to Vertical	PC-1228
 Glazing Gasket 1/8" F.C.	E2-0053		Drill Fixture	H-7204
 Glazing Gasket 1/4" F.C.	E2-0064			

FRAME FABRICATION

STEP 1 DETERMINE FRAME SIZE

Determine Frame Width:

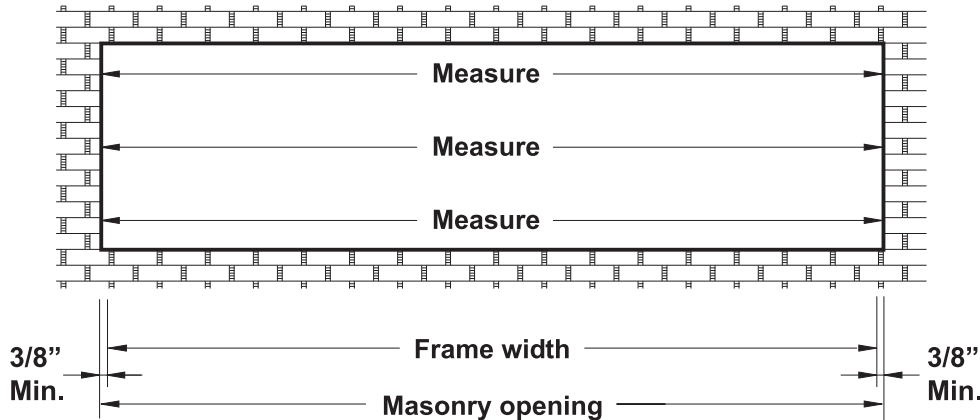

Note: Check the opening for squareness and plumb at both ends. Units must be installed in a true rectangle.

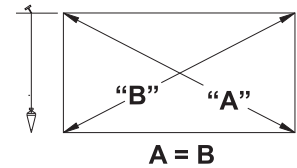

Detail 1

- Measure the width of the masonry opening at the top, middle and bottom.
- Select the smallest dimension measured and subtract 3/4" to the determine the frame width to be used. See **Detail 1**.

NOTE: Frame widths over 24'-0" require expansion mullions every 12 to 15 feet (best location at vertical next to the door jamb.)

Determine Frame Height:

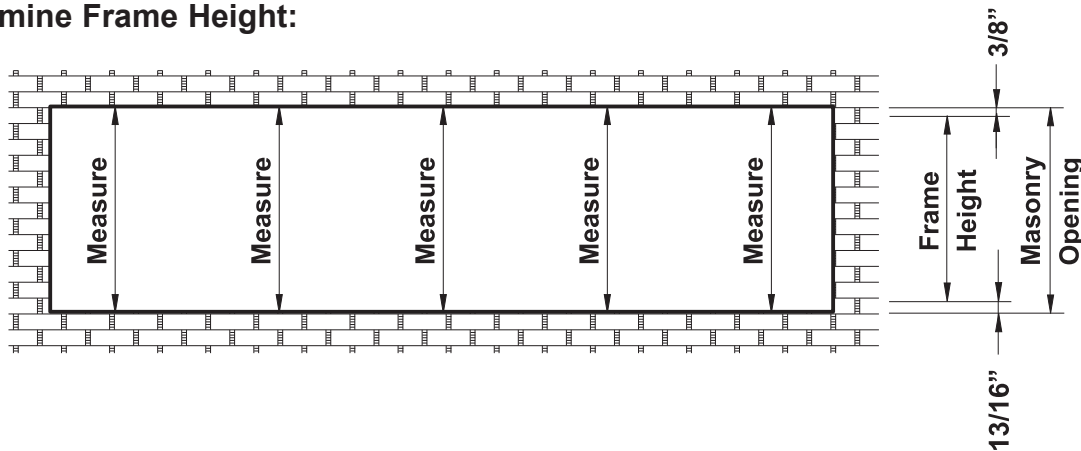

Detail 2

- Measure the height of the masonry opening in several places along the entire length of the opening.
- Select the smallest dimension measured and subtract 1-3/16" to determine the frame height to be used:

Minimum 3/8" shim/caulk joint at the head.

7/16" for sill flashing.

Minimum 3/8" shim/caulk joint below the sill flashing.

See **Detail 2**.

FRAME FABRICATION

STEP 1 DETERMINE FRAME SIZE

Determine Frame Height for Receptor Conditions:

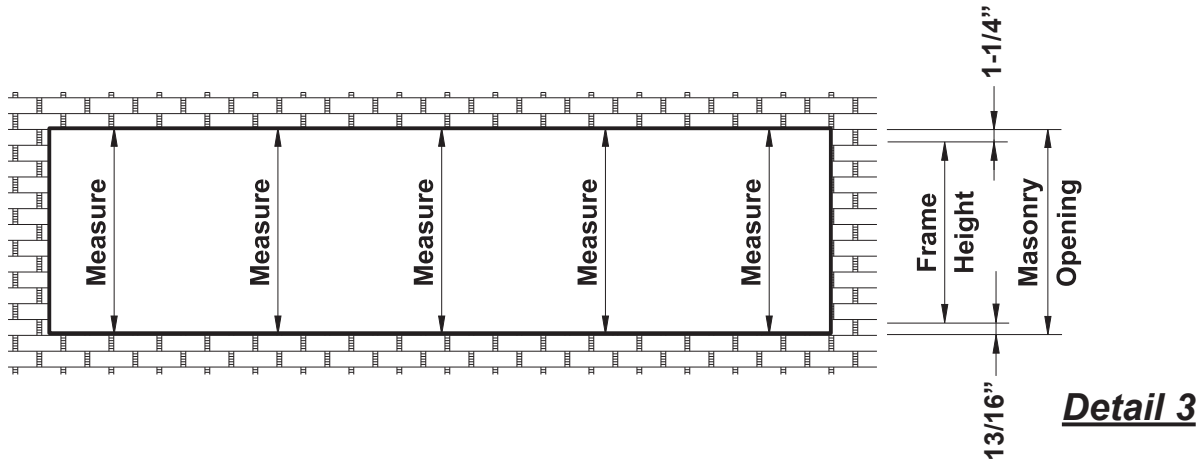

-Measure the height of the masonry opening in several places along the entire length of the opening.

-Select the smallest dimension measured and subtract 2-1/16\"

Minimum 3/8\"

7/8\"

7/16\"

Minimum 3/8\"

See **Details 3 & 4**.

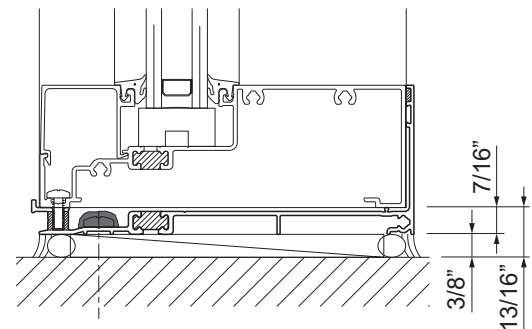
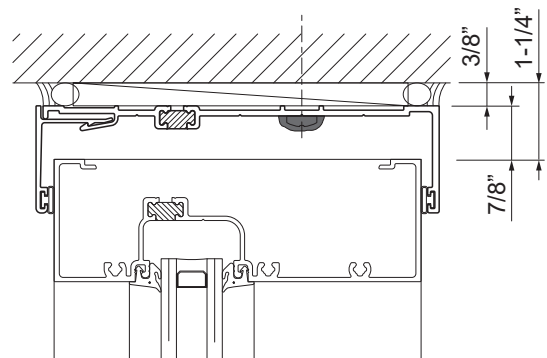

Detail 4

YES 60 TU shown

YES 60 FI similar

FRAME FABRICATION

STEP 2 FABRICATE TWO PIECE VERTICAL MULLIONS FOR SCREW SPLINE ASSEMBLY

-Cut the two piece vertical and jamb members to the frame height determined in **Step 1**.
-Fabricate holes in vertical members for screw spline attachment using one of the methods below:

1. Layout the hole locations as shown in **Detail 5** and drill a 0.236" dia. (#B drill bit) clearance hole at each location marked.
2. Use the YKK AP drill fixture, H-7204, to drill the holes.
3. Use punch press with appropriate die set.

See **Detail 5**.

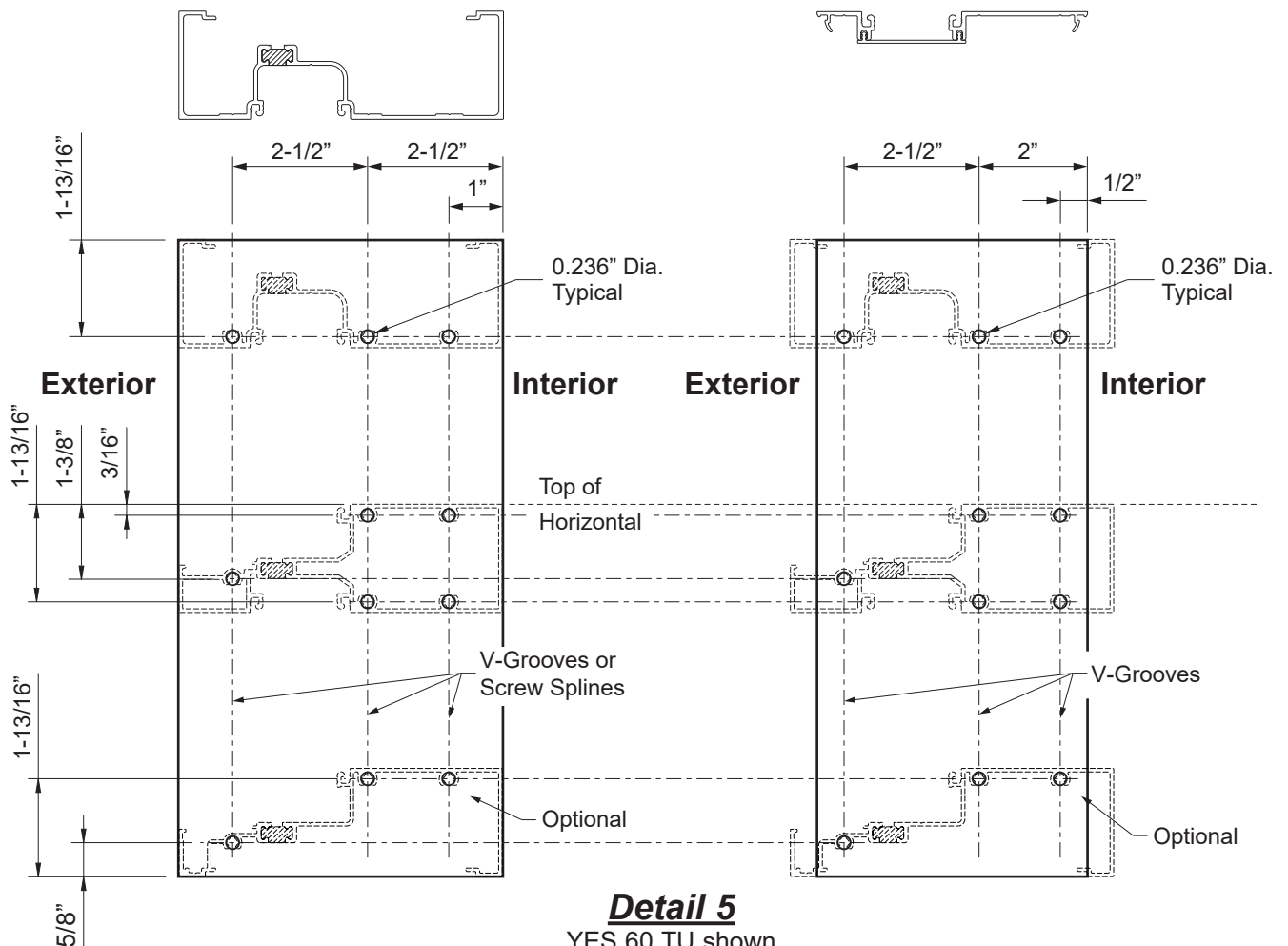

Detail 5
YES 60 TU shown
YES 60 FI similar

FRAME FABRICATION**STEP 3****FABRICATE HEAD, HORIZONTAL & SILL MEMBERS**

-Cut head, horizontal, and sill members to the daylight opening (D.L.O.) as indicated on the shop drawings.

STEP 4**FABRICATE GLASS STOPS & GLAZING ADAPTORS**

-Cut glass stops to the same dimensions as their respective horizontals minus(-) 1/32".

-Cut vertical glazing adaptors to the frame height.

-Cut horizontal glazing adaptors to the daylight opening minus(-) 1/32".

FRAME FABRICATION

STEP 5 FABRICATE HOLES FOR SILL MEMBERS

-For mullion end reactions over 500 lbs., fabricate sill members for anchoring to sill flashing:

-Measure in 6" from each end of the sill member and mark hole locations along the "V"-groove as shown in **Detail 6**.

-Mark additional hole locations a maximum of 24" on center (O.C.).

-Drill a 0.213" diameter (#3 drill bit) hole at each location marked.

-If mullion end reaction is under 500 lbs., one (1) 0.213" dia. weep hole is required at the center of each daylight opening.

See **Detail 6**.

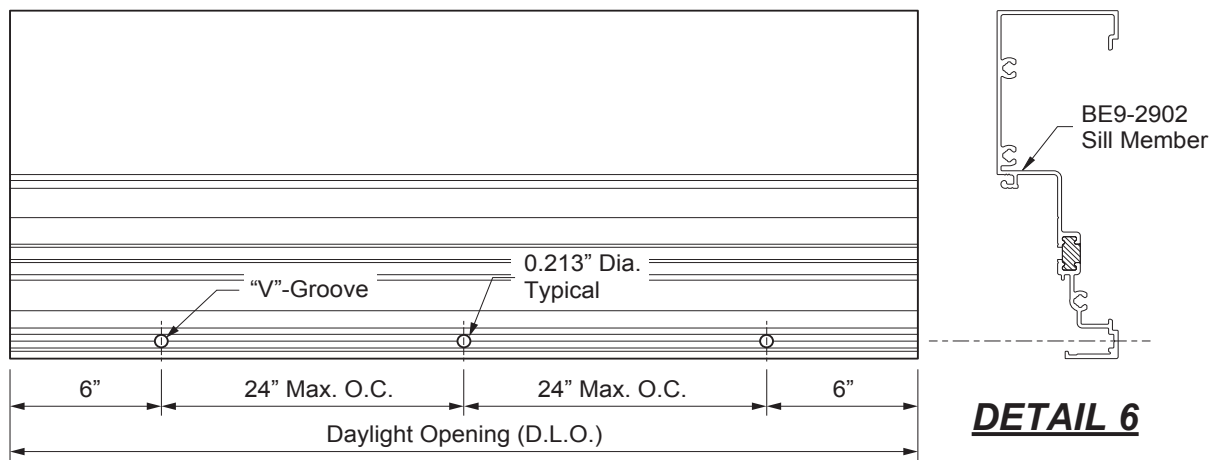

STEP 6 FABRICATE SILL FLASHING

For elevations without door framing:

-Cut sill flashing, E9-2901 / BE9-2913 to the the length of frame width plus (+) 1/4".

For elevations with door framing:

-Cut the sill flashing to length as shown in **Detail 7** and or as shown in the approved shop drawings.

FRAME FABRICATION

Without Door Framing

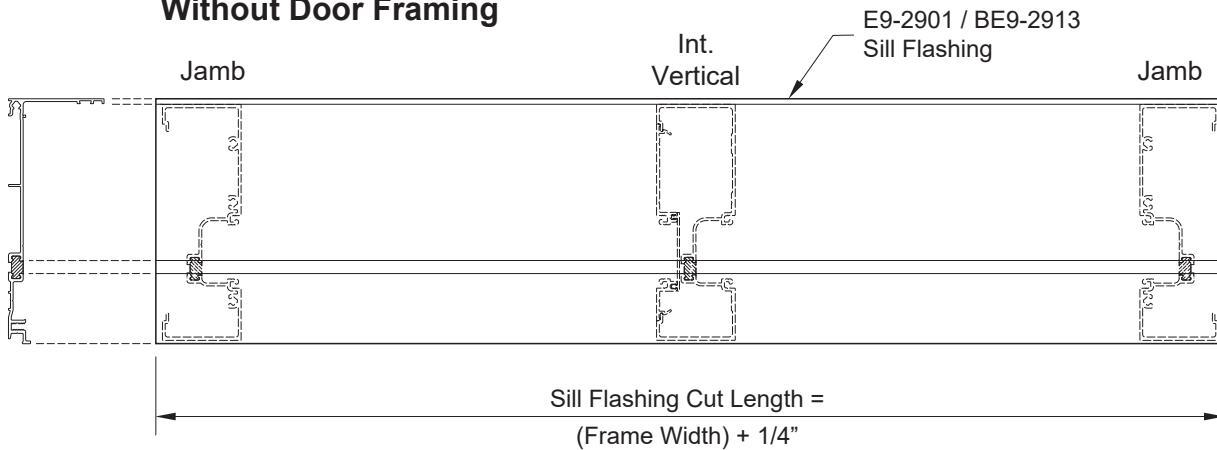

With Door Framing

Detail 7

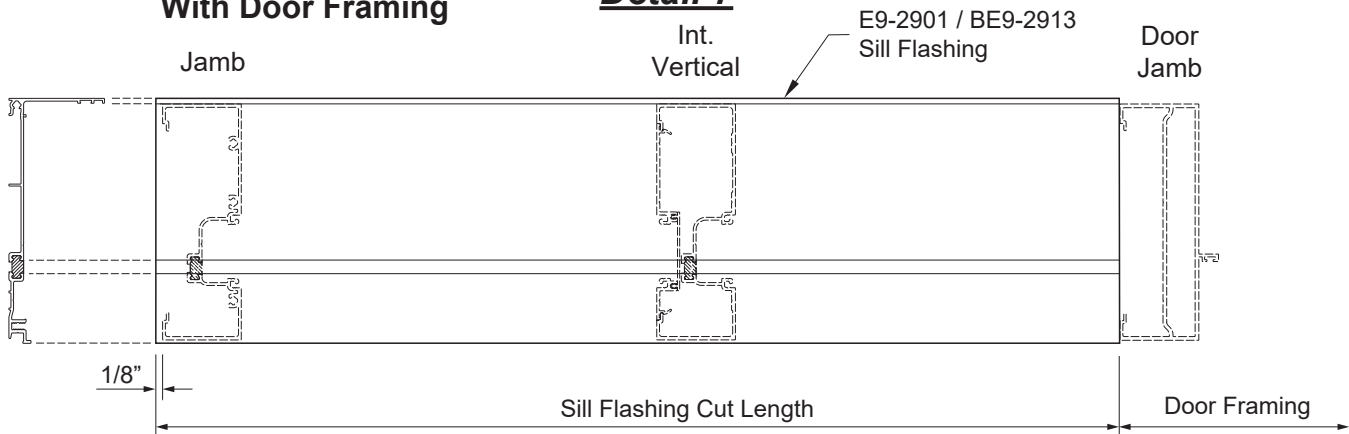

-Drill 5/16" diameter weep holes in the front of the sill flashing at the quarter points of each D.L.O.

See **Detail 8**.

DETAIL 8

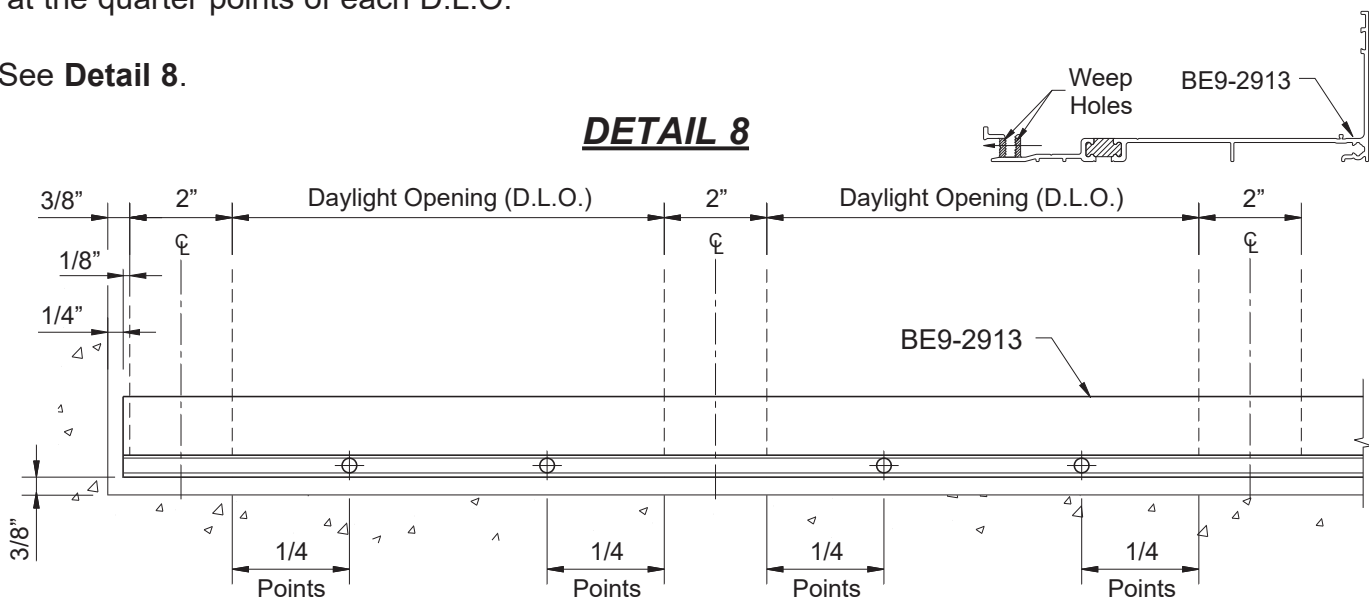

FRAME FABRICATION

STEP 6 (Continued)
FABRICATE SILL FLASHING

- For openings longer than 24'-0" the sill flashing needs to be spliced every twelve to fifteen feet at the center of a D.L.O.
- Allow for a 3/8" joint for expansion between sill flashing members.

See **Detail 9**.

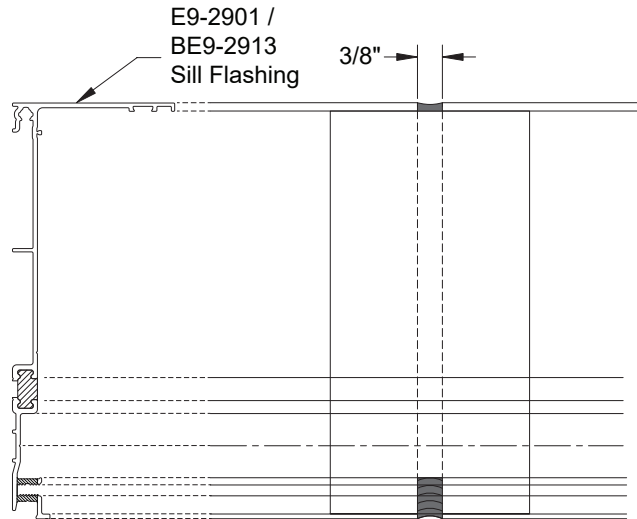

DETAIL 9

STEP 6A
FABRICATE HEAD RECEPTOR

- Cut the head receptor BE9-7361/E9-7361 and the E9-1033 snap cover to the frame width + 1/8" at each jamb or as indicated on the approved shop drawings.
- At each jamb, drill two Ø0.189" tap holes in to the E9-7361/BE9-7361 head receptor as shown.
- For openings longer than 24'-0" the head receptor needs to be spliced every twelve to fifteen feet at the center of a D.L.O.
- Allow for a 3/8" joint for expansion between head receptor members.

See **Detail 10**.

* **Note:** The Ø0.189" tap hole in the exterior side of the receptor will be slightly off the V-Groove. Drilling this hole from the top side of the receptor after the interior side hole is recommended.

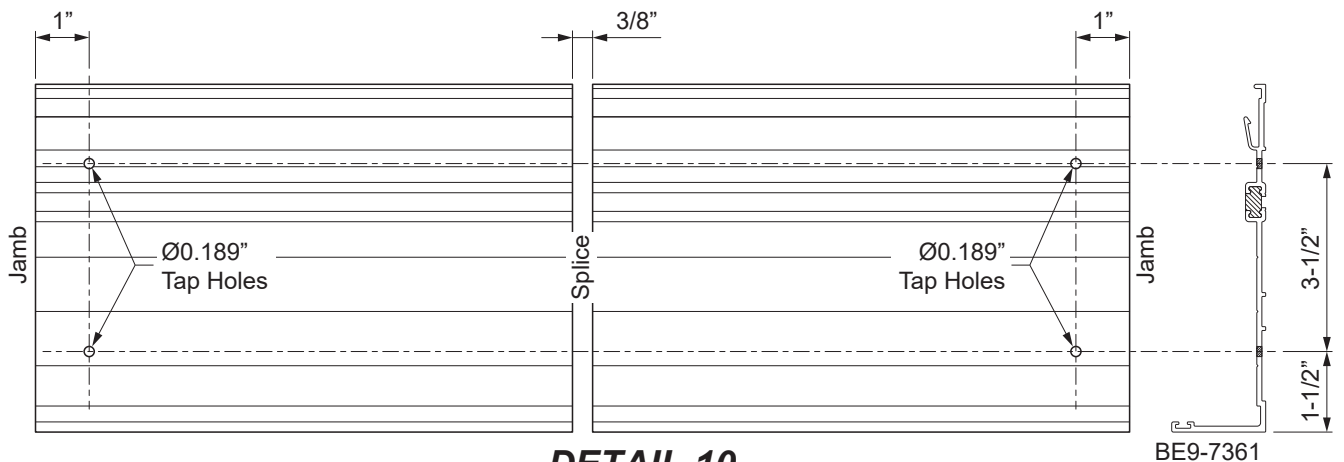

DETAIL 10

YES 60 TU shown, YES 60 FI similar

FRAME ASSEMBLY

STEP 7

ASSEMBLE FRAMES (SCREW SPLINE ASSEMBLY)

- Clean all joint surfaces using cleaner approved by sealant manufacturer.
- Apply sealant to both ends of head, horizontal and sill members just prior to assembly.
- Install a small piece of backer rod into the hollow area under the glass pocket 1/8" beyond the end of the horizontal. Apply silicone to the hollow section and tool flat to the end of the horizontal as shown.
- Attach head, intermediate horizontal, and sill members to vertical mullions and pocket fillers with PC-1216 fasteners at each end as shown in **Detail 11**.

Note: Fastener PC-1220 must be substituted for PC-1216 when the head member (with screw splines) is used as a vertical.

- Tool the sealant into the joints and wipe away any excess sealant.
- See **Detail 11**.

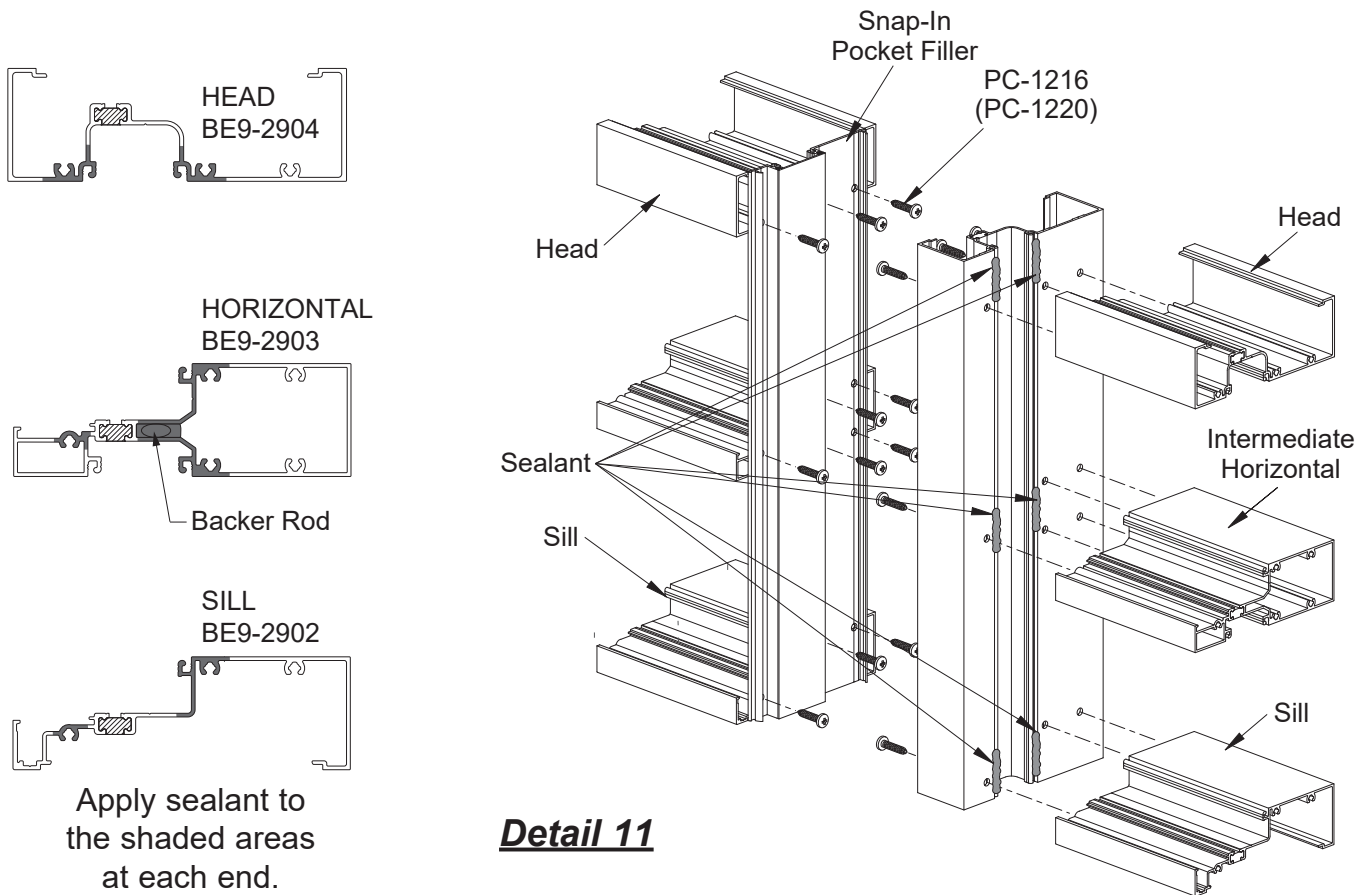

CAUTION: Always assemble frames such that each lite of glass will have a minimum of one deep vertical glazing pocket.

FRAME ASSEMBLY

STEP 8 (Not necessary with Head Receptor) INSTALL FOAM PLUGS AT HEAD

-Cut pieces of E2-0259 foam backer tape (maximum 1-7/8" long for typical mullion) to be adhered at the head only.

These will serve as end cap support for perimeter backer rods and sealant.

-Peel the adhesive tape from the foam pieces and adhere them to the front and back of the mullion as shown in **Detail 12**. The foam can be easily compressed to accommodate obstacles in the assembled verticals.

Notes: For best adhesion, ensure the contact surfaces of the verticals are clean and dry.
Backer tape application is similar for expansion and corner mullions

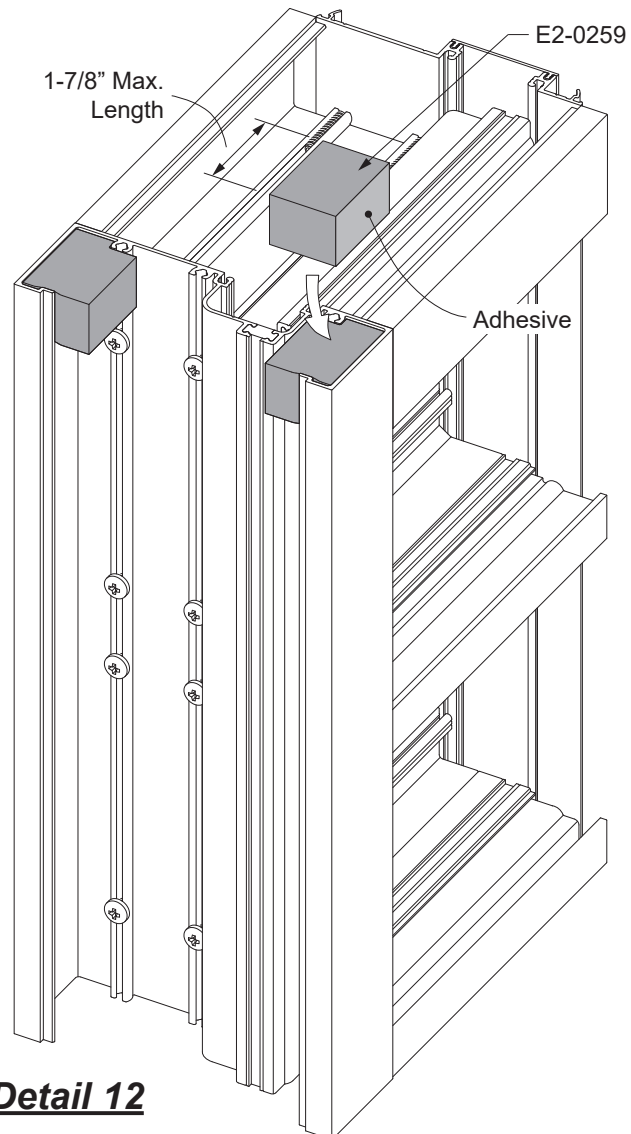

Detail 12

FRAME INSTALLATION

**STEP 9
INSTALL SILL FLASHING END DAMS**

-Bend the end dam tab left or right 90 degrees in order to “hand” the end dam for the left or right end of the flashing.

See **Details 13 & 14.**

- Clean all joint surfaces using cleaner approved by sealant manufacturer.
- Apply sealant to the end of the sill flashing as shown in **Detail 15.**
- Slide the tab into the top portion of the sill flashing.
- Tap the tab into place with a small tool until the end dam is snug against the end of the flashing.
- Fasten the end dam to the sill flashing with two UA-1212 screws, starting at the back, followed by the front as shown in **Detail 15.**
- Tool sealant along the joint between the end dam and the sill flashing as shown in **Detail 16.**
- Seal over any exposed screw threads.

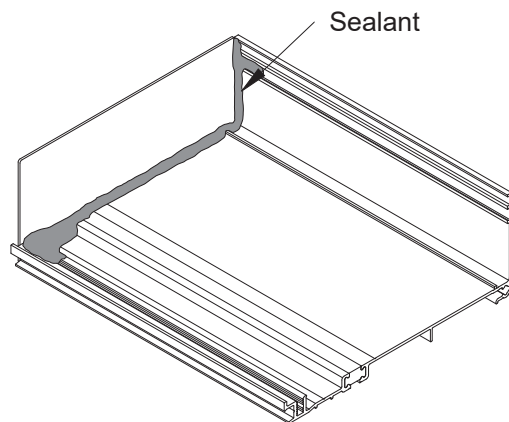
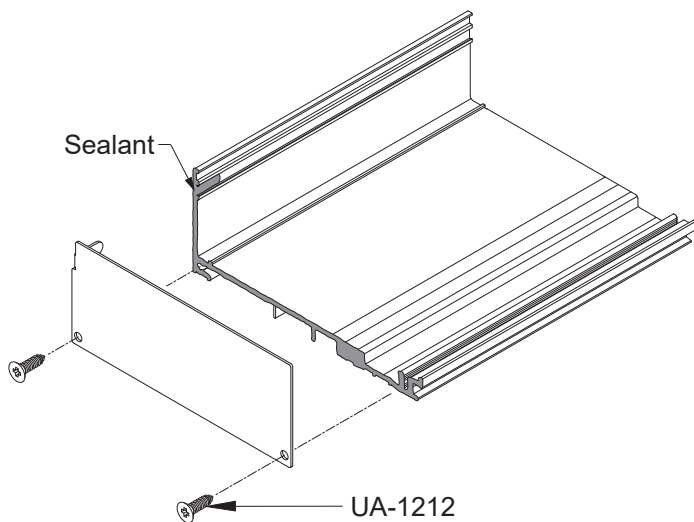
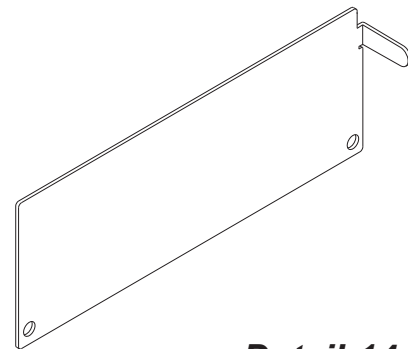
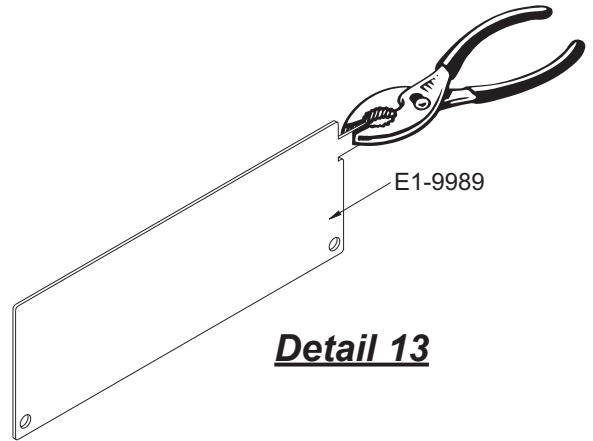

FRAME INSTALLATION

STEP 10 INSTALL SILL FLASHING

- Install the sill flashing with a minimum of 3/8" shim space underneath. Sill flashing must be installed level.
- Anchor the sill flashing to the structure a maximum of 4" from each end and then 18" to 24" on center, or per P.E. calculations.
- Apply and tool sealant to cover the heads of all anchors and screws.

STEP 11 INSTALL SILL FLASHING SPLICE SLEEVE

- Remove the nub with a chisel or pliers on both sides of the splice joint 1-1/2" as shown in **Detail 17**.
- After the sill flashing has been shimmed and anchored to the building structure, insert a small backer rod under the sill flashing as shown in **Detail 18**.
- Position the Silicone Splice Sleeve against the back wall below the groove.
- Bend the Silicone Splice Sleeve into the front on the channel as shown. Mark and cut the sleeve at this position.
- Clean Sill Flashing and Silicone Splice Sleeve with isopropyl alcohol at the splice location.
- Seal the flashing at the splice location as shown in **Detail 18**, before positioning the flashing. Set the Silicone Splice Sleeve into the sealant.
- Tool sealant tight as shown in **Detail 18**, squeezing the sheet flat with a seam roller.

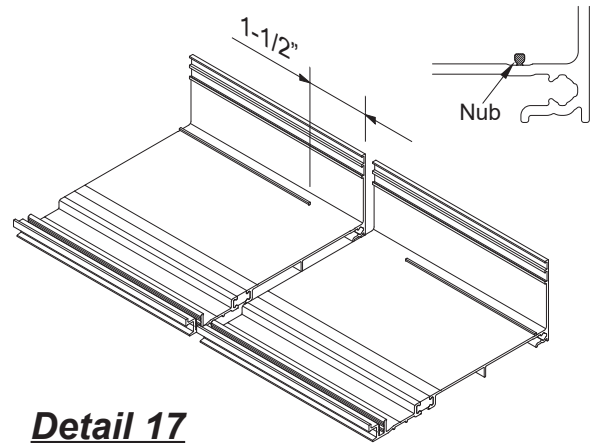

Detail 17

When using E2-0070, a compatible Silicone Sealant must be used at the splice. Compatible Silicone Sealants include Tremco® Spectrem 2 and Dow Corning® 795.

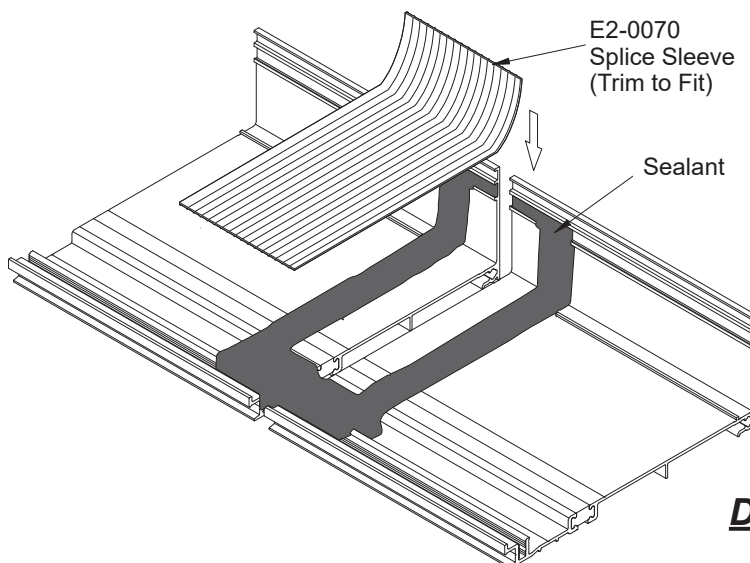

Detail 18

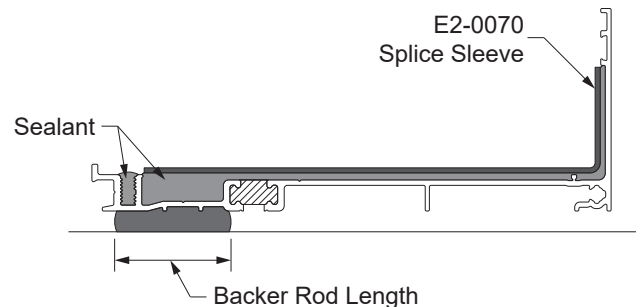

FRAME INSTALLATION

**STEP 11
INSTALL SILL FLASHING SPLICE SLEEVE (Continued)**

- Apply masking tape to the back of the sill flashing at the splice and at the front as shown in **Detail 19**.
- Thoroughly seal the small joint directly in front of the Silicone Splice Sleeve. Carefully remove masking tape from the front gap before the sealant skins over.

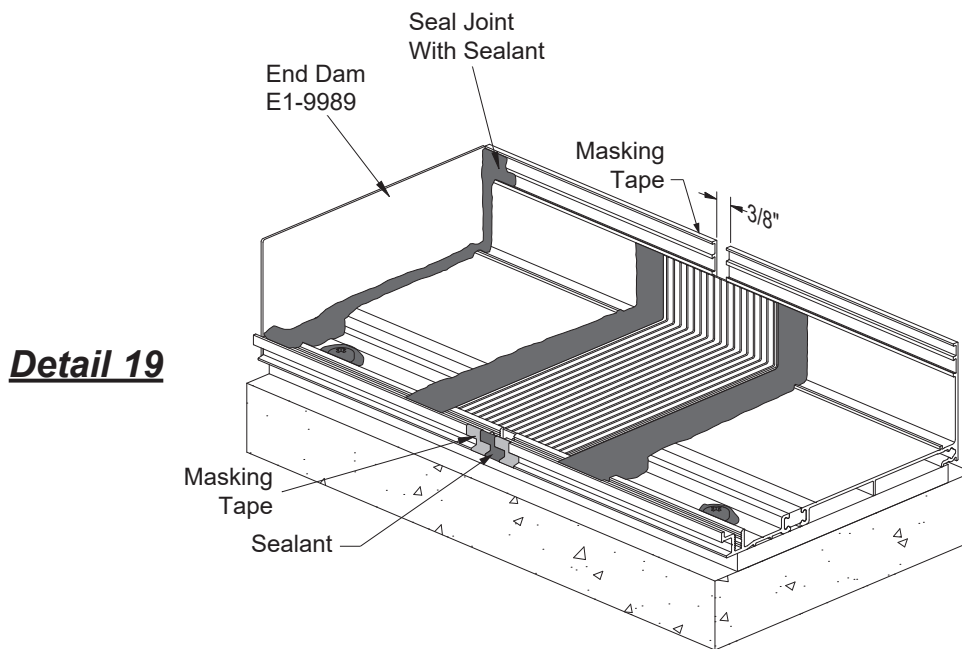

**STEP 12
SILL PREPARATION**

- At every splice condition, apply bond breaker tape to the back of the sill member before the joint is sealed between the sill and sill flashing.
See **Detail 20**.

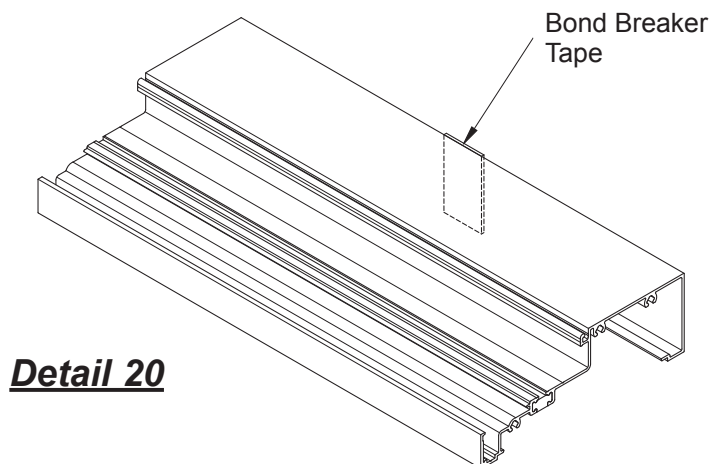

FRAME INSTALLATION

STEP 13 ATTACH HEAD RECEPTOR END CAPS

-Cut E2-0051 bulb gaskets to the same length as the head receptor and insert them into the reglet of both the E9-7361 / BE9-7361 head receptor and E9-1033 snap cover. See **Detail 21**.

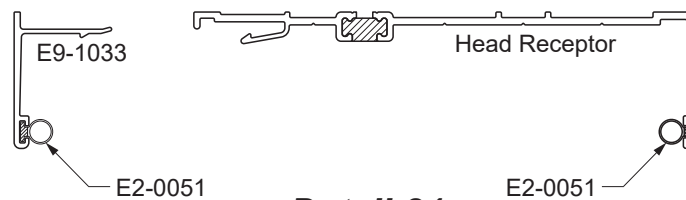

Detail 21

YES 60 TU shown (BE9-7361)
YES 60 FI similar (E9-7361)

- Clean all joint surfaces using cleaner approved by sealant manufacturer.
- Apply sealant to the end of the head receptor as shown in **Detail 22**.
- Fasten the E1-2908 end caps to each jamb using two FC-1208 fasteners.
- Tool sealant to the inside of the end caps at the jambs similar to that for the sill flashing end dams (see **Detail 24**). Tape down the top corners to hold the end cap in place until the sealant cures.

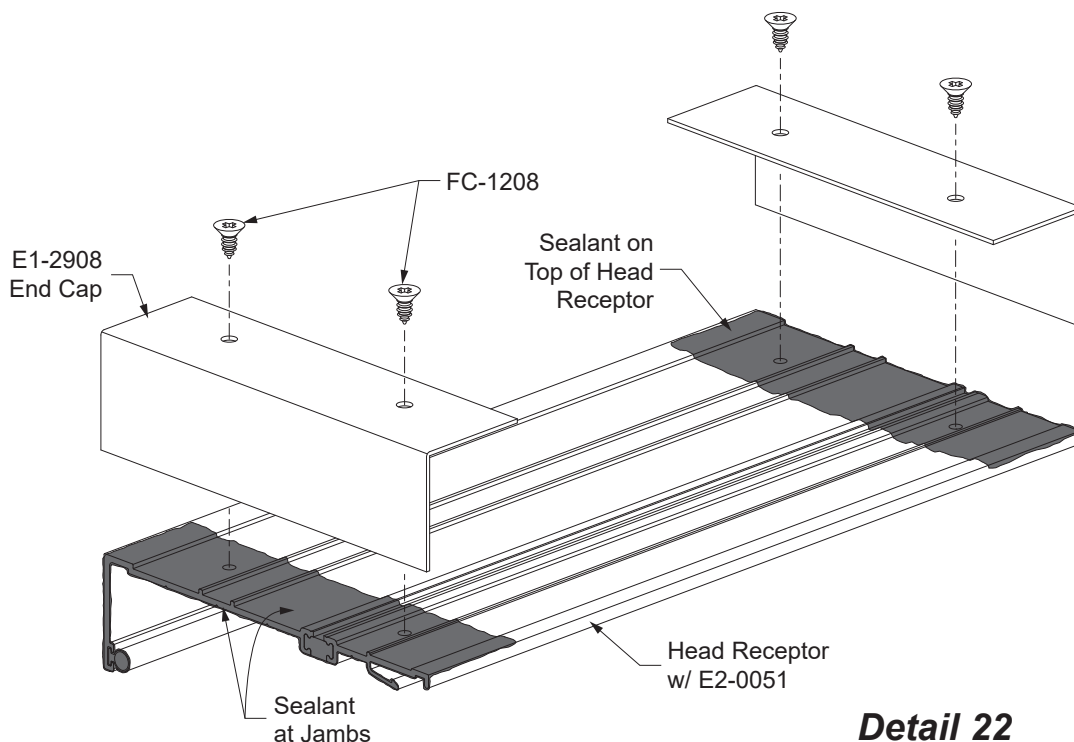

Detail 22

YES 60 TU shown (BE9-7361)
YES 60 FI similar (E9-7361)

FRAME INSTALLATION

**STEP 13
INSTALL RECEPTOR**

-Install the E9-7361 / BE9-7361 head receptor to the substrate using fasteners per approved shop drawing or P.E. calculations.

Allow for a 3/8" shim space to the substrate and a 3/8" gap at the splice joints.

-Seal all anchor fastener heads.

-Fill the gap at the exterior of the head receptor with sealant.

See **Details 23 & 24.**

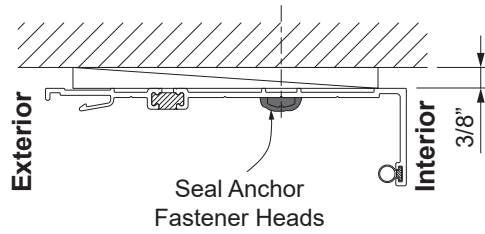

Detail 23
YES 60 TU shown
YES 60 FI similar

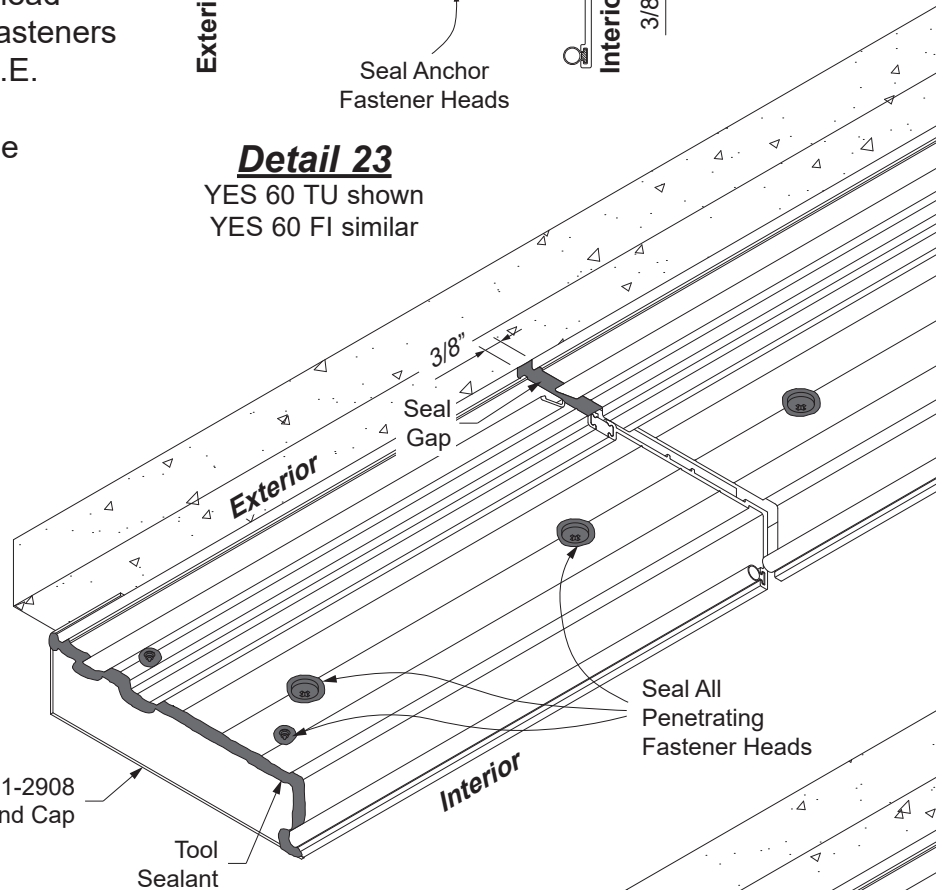

Detail 24
YES 60 TU shown
YES 60 FI similar

-Adhere an E2-0070 silicone sheet to the splice joints on a bed of sealant. Fill the gap at the back of the head receptor with sealant.

See **Detail 25.**

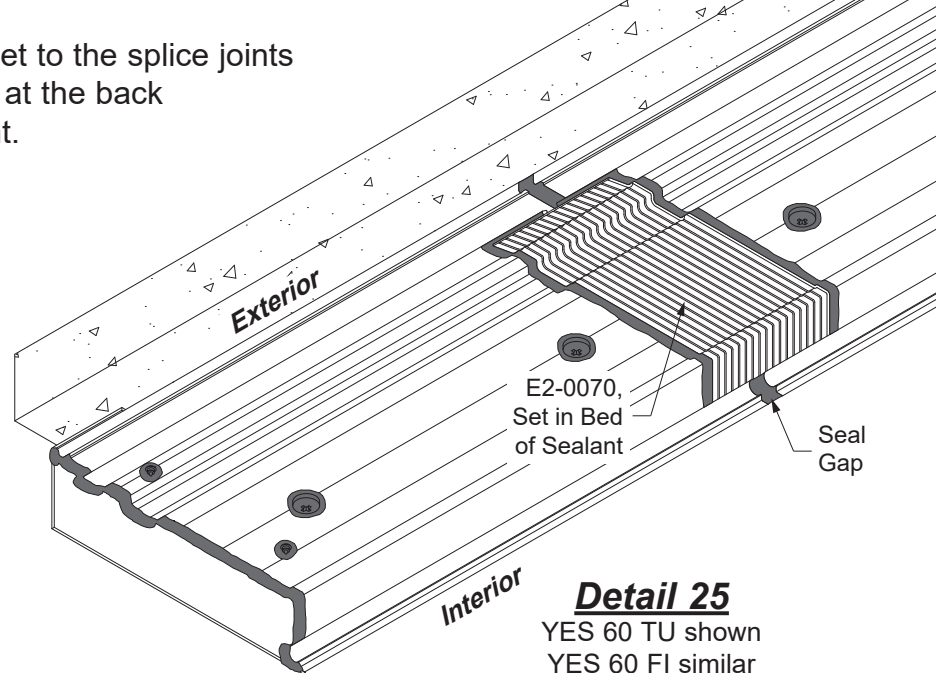

Detail 25
YES 60 TU shown
YES 60 FI similar

FRAME INSTALLATION

STEP 14 INSTALL SILL FLASHING FOR CORNERS

- Cut two 12" long pieces of sill flashing E9-2901 / BE9-2913 and miter (45° for 90° corners and 67.5° for 135° corners).
- Align the two pieces at the corner condition with the mitered ends pushed together tight and anchor the sill flashing as called out on shop drawings.
- Apply and tool sealant to the mitered joint and anchor heads.
- See **Detail 26**.
- Continue installing the rest of the sill flashing providing a 3/8" expansion joint at splices as shown in **Step 11** on **Page 15**.

* **Note:** Similar technique required for E9-7361 / BE9-7361 head receptor.

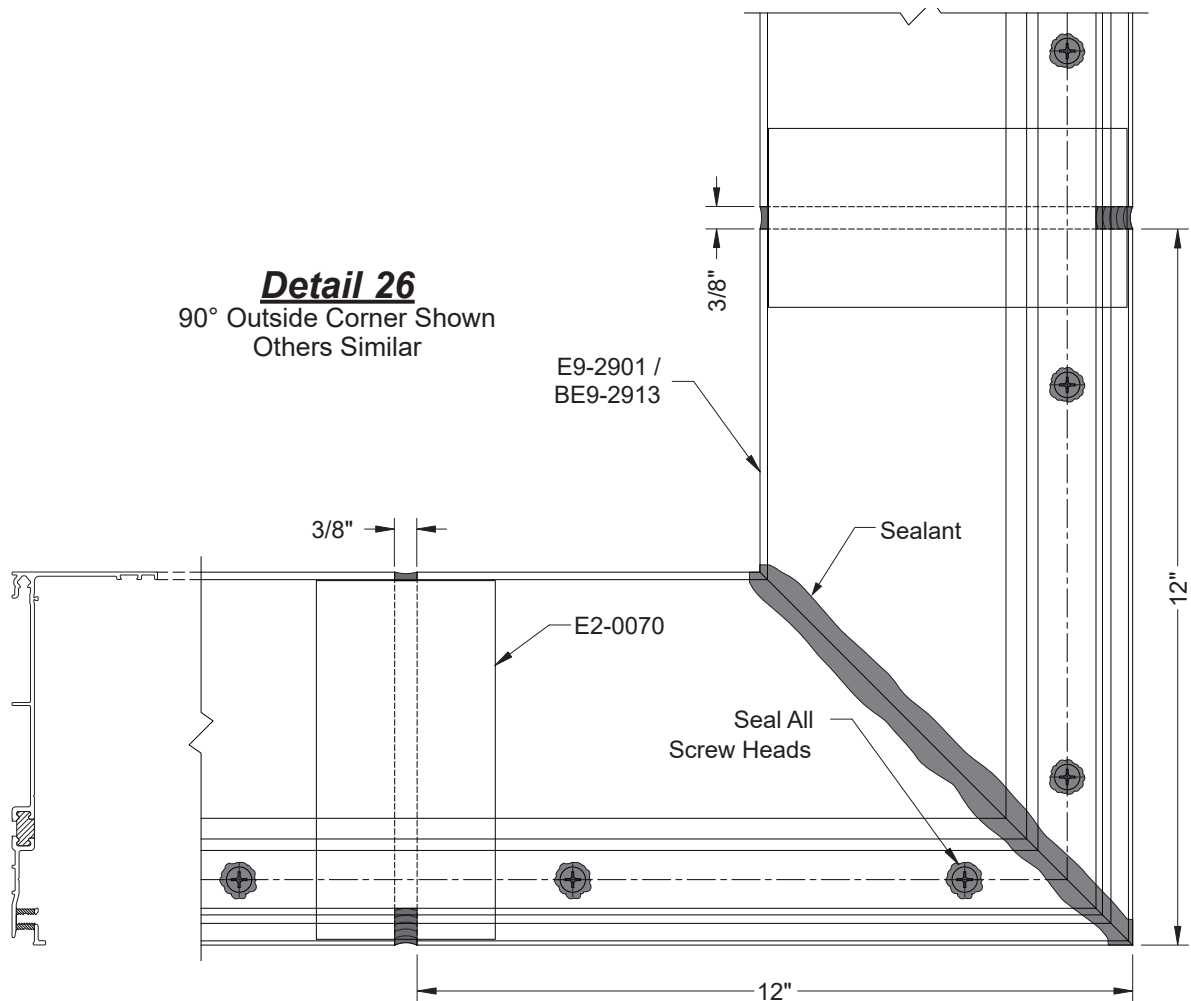

FRAME INSTALLATION

**STEP 15
PREPARE DOOR JAMBS**

Prior to snapping the assembled frames into the door jamb, the end of the sill flashing needs to be sealed to the door jamb.

- Apply and tool sealant at all sill flashing to door jamb joints.
- Apply sealant to completely fill the door jamb cavity and ramp the sealant down onto the sill flashing.

See **Detail 27**.

Refer to the **Entrances Installation Manual** for door installation instructions.

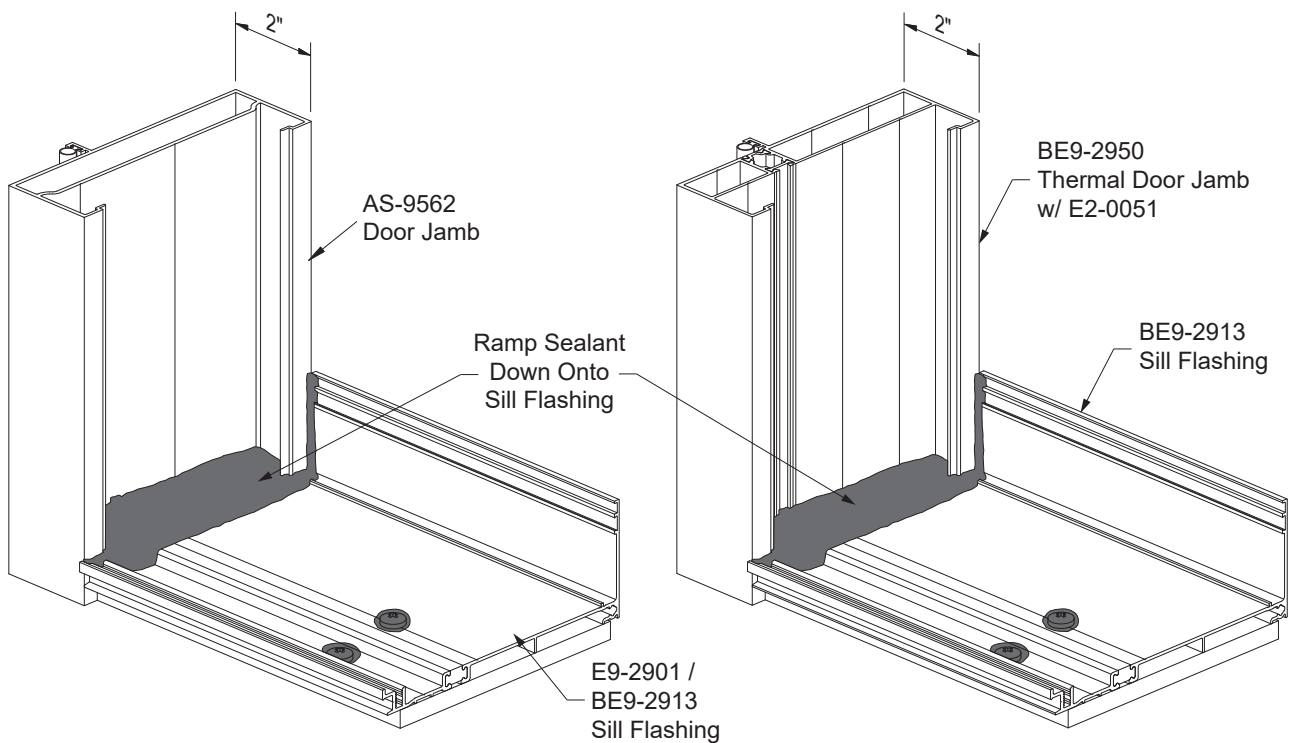

Detail 27

FRAME INSTALLATION

STEP 16 INSTALL FRAMES

- Snap in flat fillers, E1-2903, or 2-1/2" long pieces of BE9-7362 at head and jamb anchor locations (E1-2904 for YES 60 FI.)
- Prior to snapping the assemble frames together, apply sealant to the interior snap interface of the mullion, 6" up from the bottom.
- Apply sealant continuously to the front of the back leg of the sill flashing and immediately set the frame into the opening.
- Snap assembled frames together if using screw spline assembly.

See **Detail 28**.

- Shim jamb and head members with a minimum of 3/8" shim.
- Anchor the frame to the structure at the sill*, head, and jamb: 3" from the ends and then 24" on center, or as required by P. E. calculations.
- Always shim at all anchor locations.

Note: Use only flat head fasteners at head and jamb conditions.

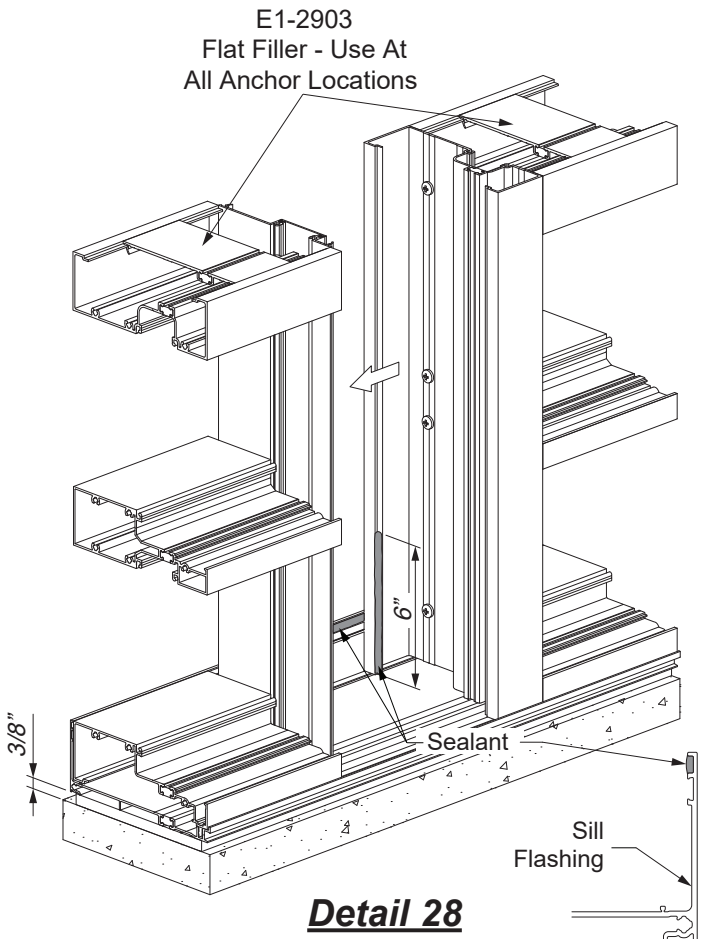

Detail 28

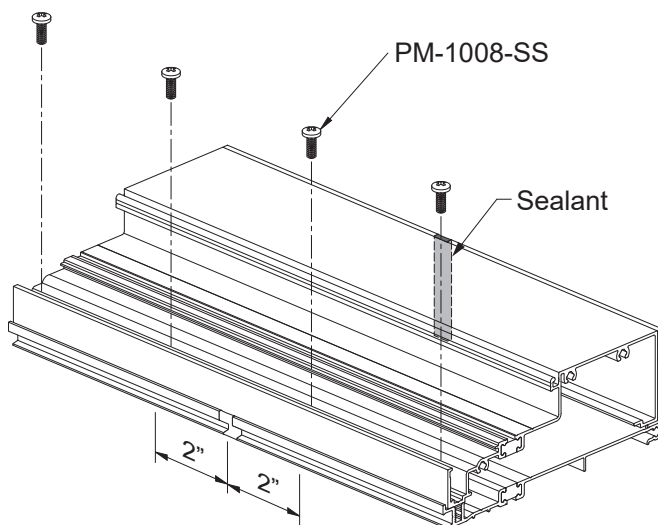

Detail 29

- For mullion end load reactions over 500 lbs., attach the sill to the sill flashing using PM-1008-SS screws.*
- Also add one (1) PM-1008-SS fastener 2" in both directions from the center line of the splice.

-Apply and tool sealant to the gap in the back of the sill flashing splice. Remove the masking tape after application.
See **Detail 29**.

*To determine end load reactions, consult YKK AP DirecTech or refer to approved shop drawings or P. E. calculations.

FRAME INSTALLATION

**STEP 16 (Continued)
INSTALL FRAMES W/ HEAD RECEPTOR**

- Rotate the assembled frames into position from the exterior, ensuring engagement into the sill flashing.
- Snap on the E9-1033 snap cover (with E2-0051 bulb gasket) into the head receptor.
- For mullion end load reactions over 500 lbs., attach the sill to the sill flashing using PM-1008-SS screws. Also add one (1) PM-1008-SS fastener 2" in both directions from the center line of the splice.

See **Detail 30**.

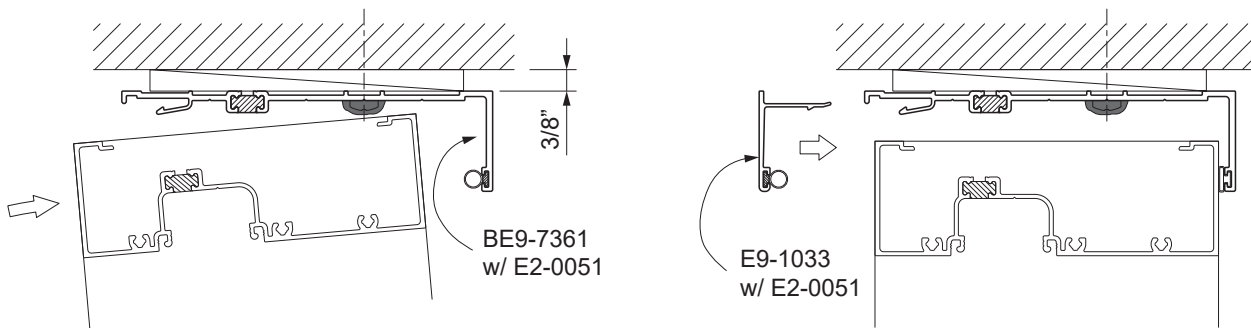

Detail 30

YES 60 TU shown
YES 60 FI similar

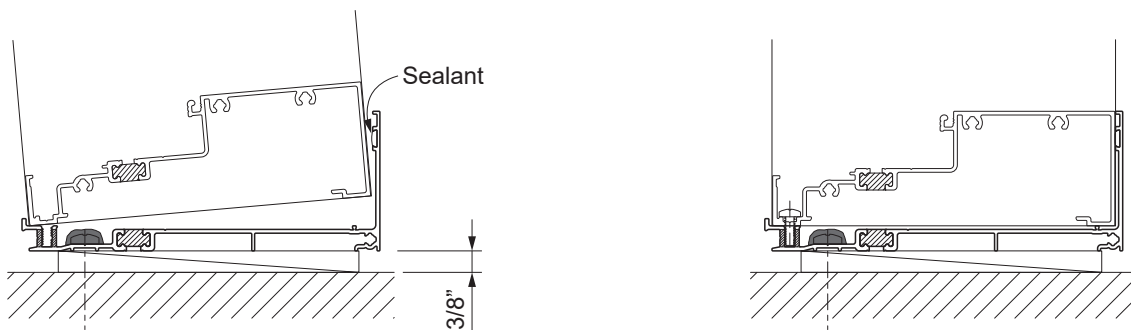

FRAME INSTALLATION

STEP 16 (Continued)

INSTALL EXPANSION MULLIONS WHERE REQUIRED

- Expansion mullions require the K2-2441 weathering gasket in both front and rear reglets.
- During installation, the current air temperature should be taken into account to determine the proper spacing between the mullion halves such that the expansion mullion stays within its allowable width limits during its service in hot and cold weather conditions.
- Fill the interior gap between the mullion halves with sealant at the sill flashing and head receptor.

See **Detail 31**.

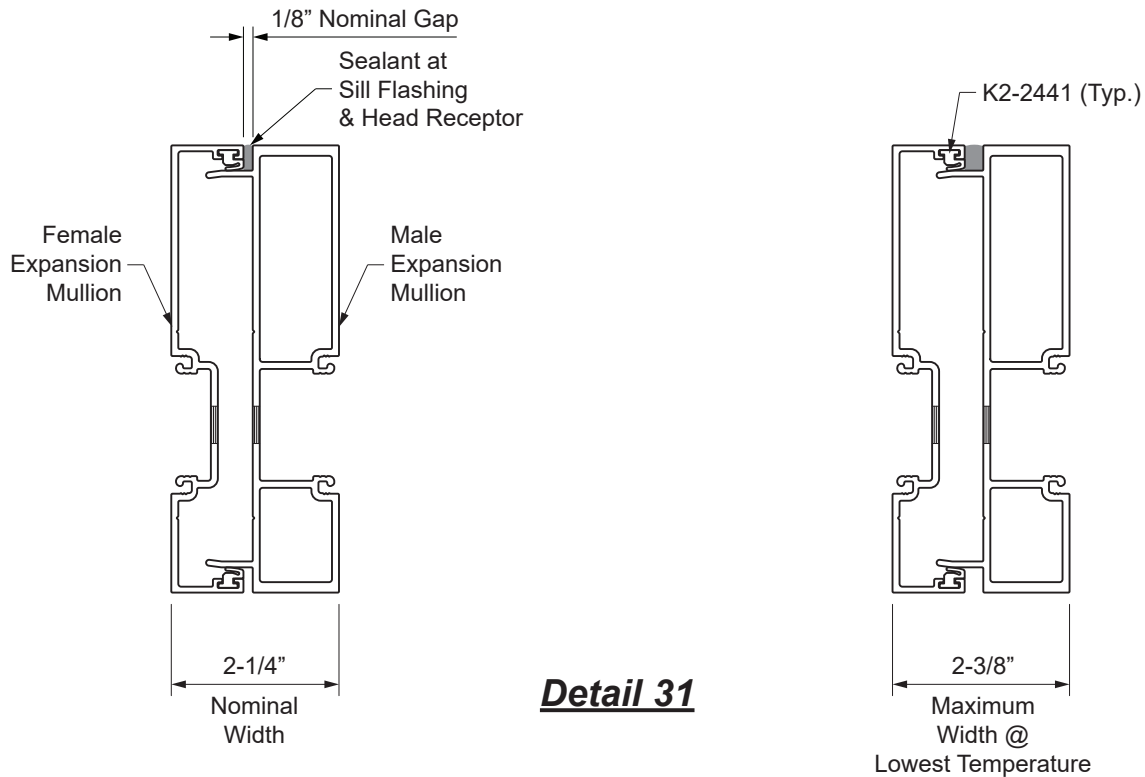

Detail 31

FRAME INSTALLATION

STEP 16 (Continued) INSTALL CORNER ASSEMBLIES

For 90° Corner Assemblies:

- Attach horizontal members to standard mullions as shown before in **Step 7**.
- Attach the other end of the horizontals to the jamb mullions to be used at the corners.
- Attach shallow pocket fillers to the jamb mullions and snap the E9-2937 / BE9-2937 adaptors to the pocket fillers.
- Apply sealant to the cavity between the adaptors at the jamb mullions. Tool the sealant. For inside corners, apply sealant to the snap receptor of the E9-2939 female corner cover, 6" up from the bottom.
- Snap the E9-2939 female corner cover onto the corner first, then snap on the E9-2938 male corner cover.

See **Detail 32**.

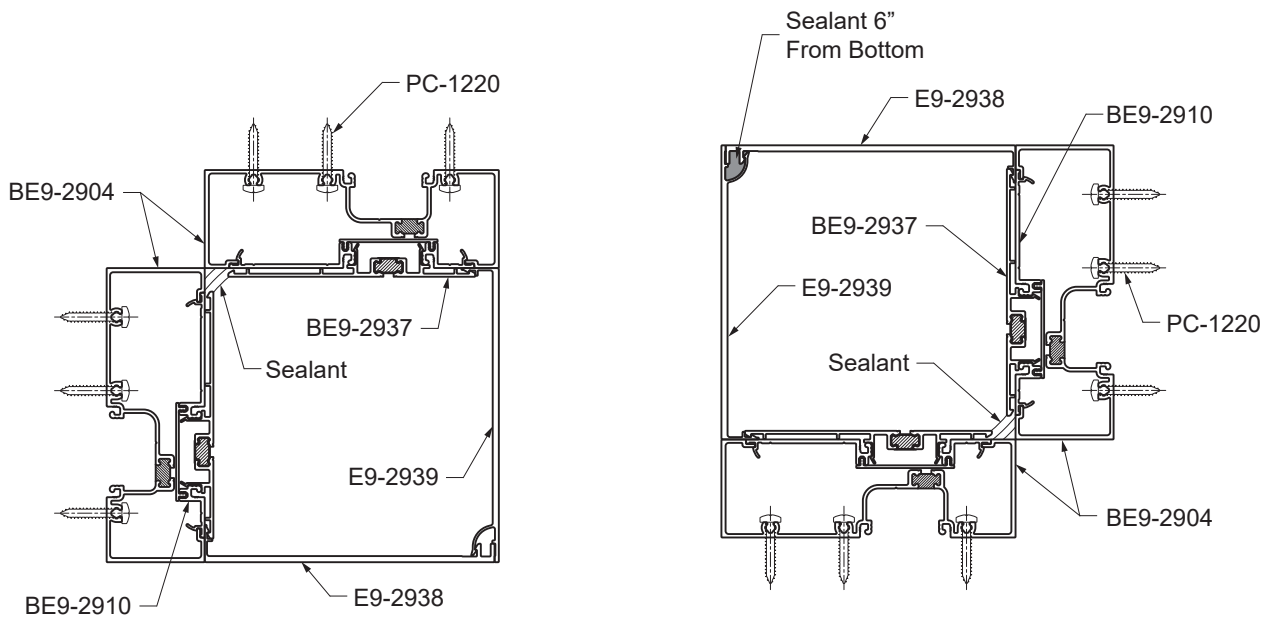

90° Outside Corner

Detail 32

YES 60 TU shown,
YES 60 FI similar

90° Inside Corner

FRAME INSTALLATION

STEP 16 (Continued) INSTALL CORNER ASSEMBLIES

For 135° Corner Assemblies:

- Attach horizontal members to standard mullions as shown before in **Step 7**.
- Attach the other end of the horizontals to the deep pocket fillers using the same technique.
- Snap the corner framing members together to form the corner assemblies.
- Carefully move the corner assembly into place and snap it into the rest of the frame one side at a time.

See **Detail 33**.

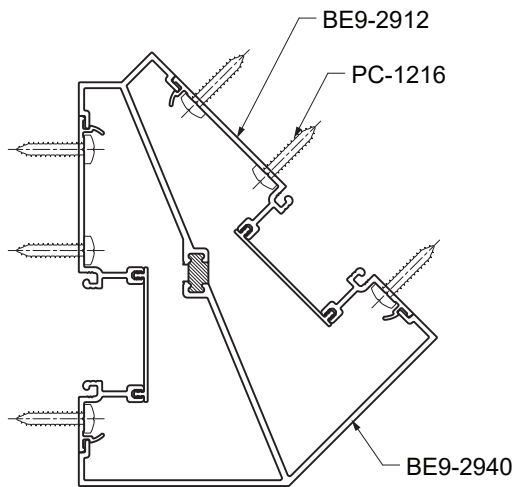

135° Outside Corner

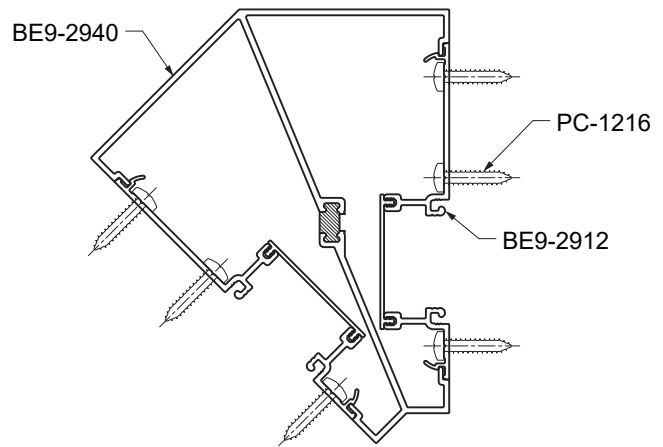

135° Inside Corner

Detail 33

YES 60 TU shown,
YES 60 FI similar

FRAME INSTALLATION

**STEP 16 (Continued)
INSTALL OPTIONAL COMPOUND MULLIONS**

-Snap in the BE9-2937 adaptors (cut full length of the mullion) into the mullions for each frame as shown in **Detail 34**.

-Apply sealant to the full length of the first mullion for which the rear face cover will snap into.

-Snap the face cover into place.

See **Detail 35**.

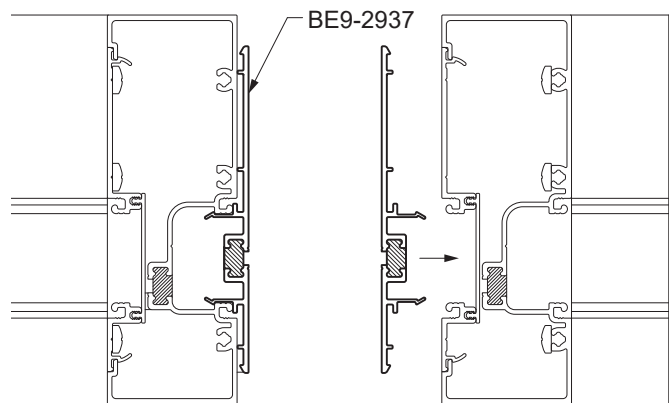

Detail 34

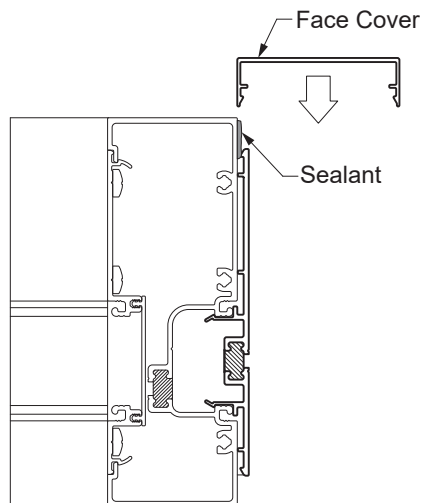

Detail 35

FRAME INSTALLATION

STEP 16 (Continued) INSTALL OPTIONAL COMPOUND MULLIONS

-Apply sealant to the full length of the mullion for the second frame.

-Snap the second frame into place from the front, engaging the face cover as shown in **Details 36 & 36A**.

-Snap the front face cover into both frames. Start at the sill to clear the front lip of the sill flashing.

See **Detail 37**.

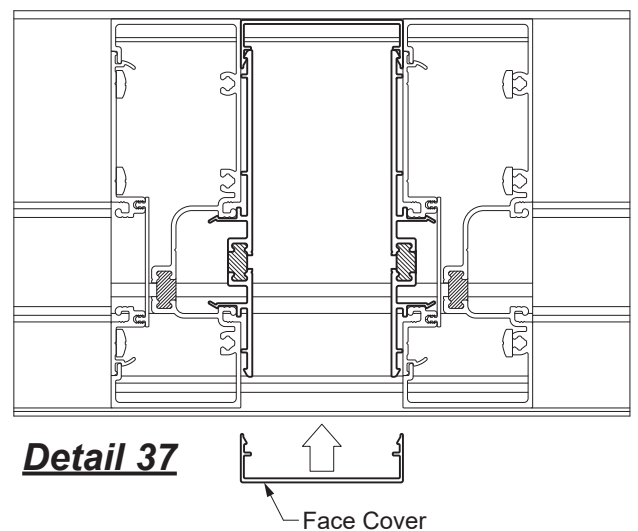
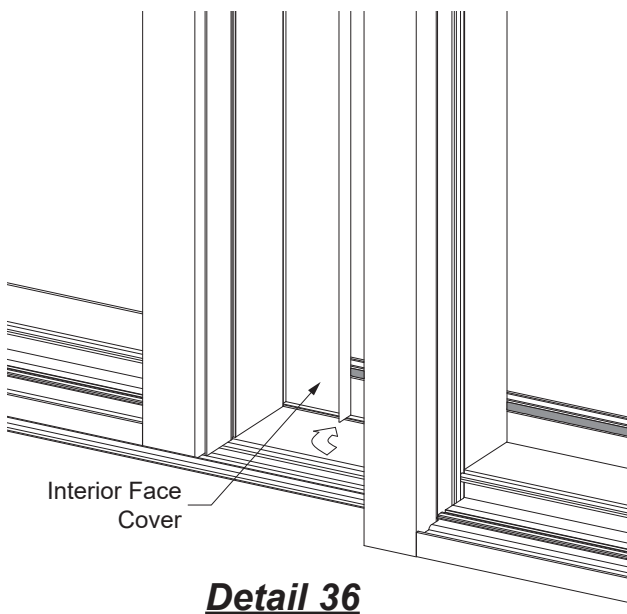
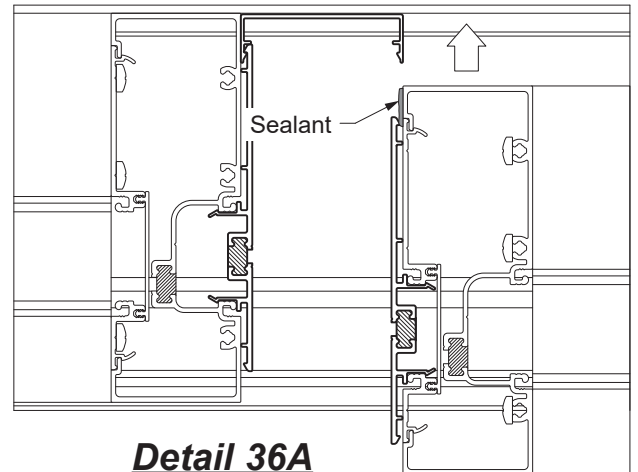

FRAME INSTALLATION

**STEP 17
APPLY PERIMETER SEALANT**

- Perimeter seal required on interior and exterior.
- Install backer rod around the perimeter of the frame.
- Apply and tool perimeter sealant to the joint between the frame and the structure.
- Do not** seal sill flashing weep holes.
- Seal anchor heads at head and jambs.

See **Detail 38**.

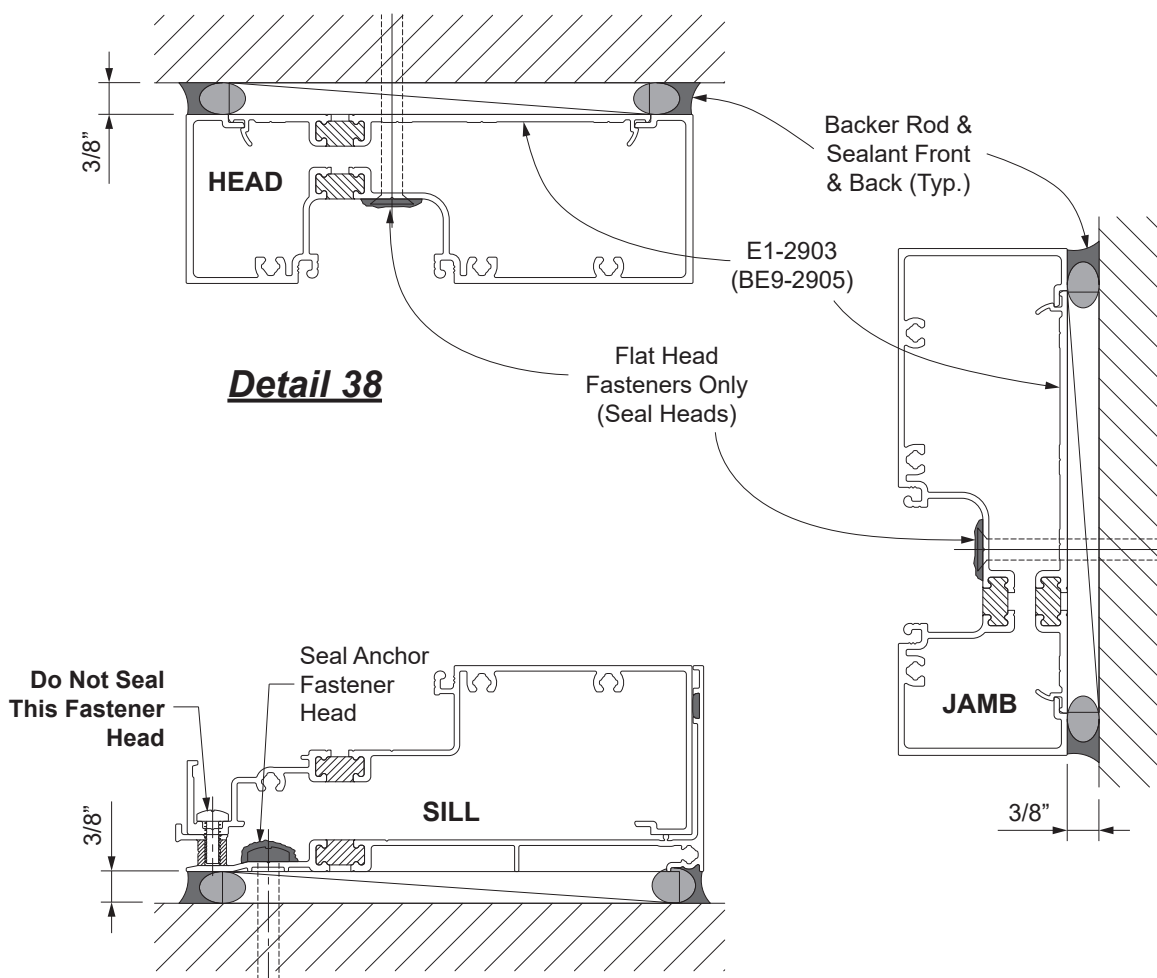

FRAME INSTALLATION

STEP 17 (Continued)

APPLY PERIMETER SEALANT @ HEAD RECEPTOR

-Insert backer rods as required into the head receptor snap cover to provide support for sealant at the exterior gap.

See **Detail 39**.

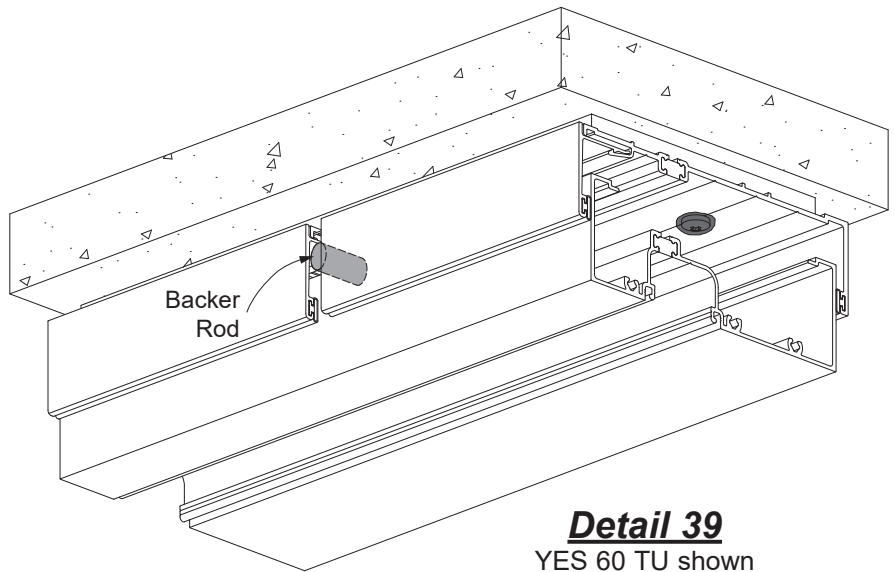

Detail 39

YES 60 TU shown
YES 60 FI similar

-Insert a continuous backer rod between the head receptor and substrate on both the interior and exterior of the frame.

-Apply and tool continuous sealant along the caulk joint and fill the gap at the exterior snap cover with sealant.

See **Detail 40**.

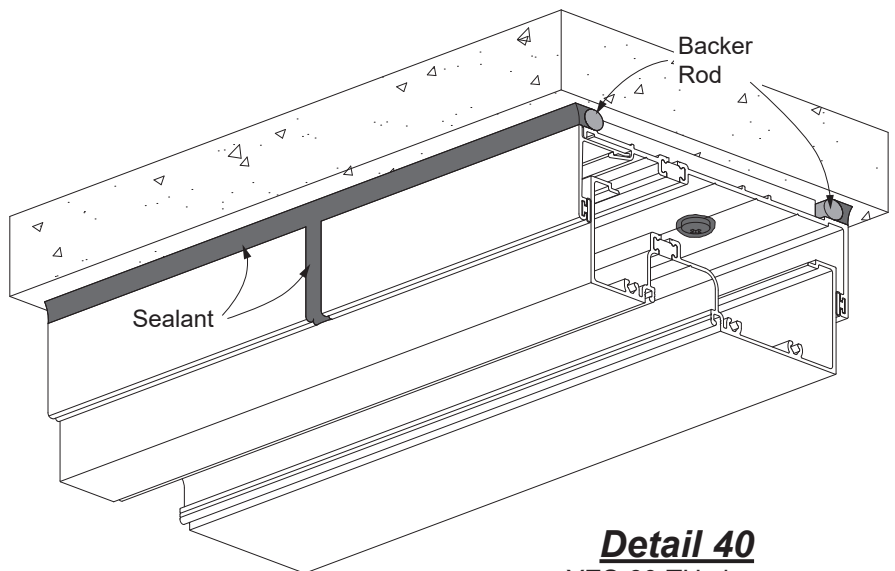

Detail 40

YES 60 TU shown
YES 60 FI similar

FRAME INSTALLATION

STEP 18 INSTALL WATER DEFLECTORS

YES 60 FI and TU requires the installation of a water deflector, E2-0047, at the ends of every intermediate horizontal to keep water off of the insulating glass units (IGU). Optional compound horizontals require water deflectors at the ends of both horizontal members.

- Peel away the protective paper from the bottom of the water deflector, E2-0047, and install the water deflector by rotating it over each end of the horizontal.
- Position the vertical leg of the water deflector against the end of the horizontal.

Note: For best adhesion, make sure that the horizontal is clean and dry.

See **Detail 41**.

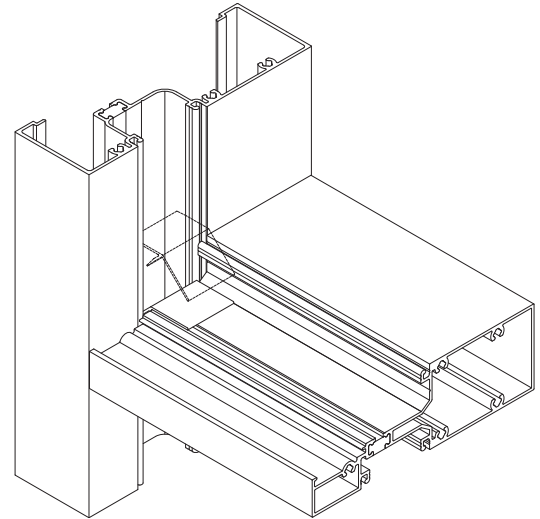

Detail 41

YES 60 TU Shown
YES 60 FI Similar

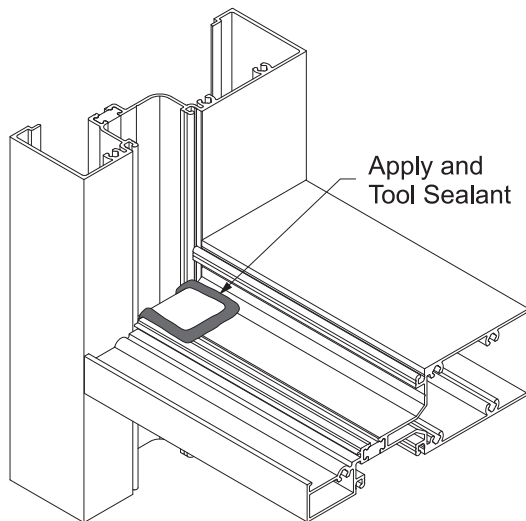

Apply and
Tool Sealant

Detail 42

YES 60 TU Shown
YES 60 FI Similar

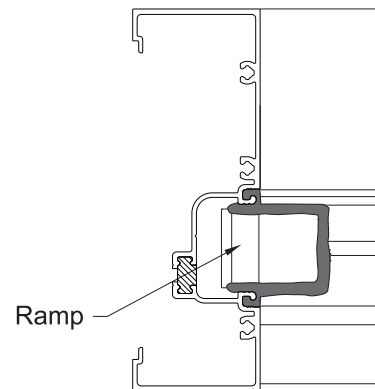

Ramp

Detail 43

YES 60 TU Shown
YES 60 FI Similar

-Apply and tool sealant along the edges of the water deflector and down onto the horizontal.
See **Detail 42**.

-Seal the ramp of the water deflector to the sides of the vertical gasket reglets.
See **Detail 43**.

FRAME INSTALLATION

STEP 19 APPLY INTERNAL SEALANT

- Apply sealant to the vertical intersection of the horizontal and vertical members.
- Tool all of the sealant to ensure a water tight joint.

See **Detail 44**.

Glazing Table - YES 60 FI/TU

Glass Thickness	Adaptor	Exterior	Interior
3/16"	E9-1040	E2-0052	E2-0064
1/4"	E9-1040	E2-0052	E2-0052
5/16"	E9-1040	E2-0053	E2-0052
3/8"	E9-1040	E2-0053	E2-0053
1/2"	E9-1039	E2-0064	E2-0064
5/8"	E9-1039	E2-0052	E2-0052
3/4"	E9-1039	E2-0053	E2-0053
7/8"	—	E2-0064	E2-0064
1"	—	E2-0052	E2-0052

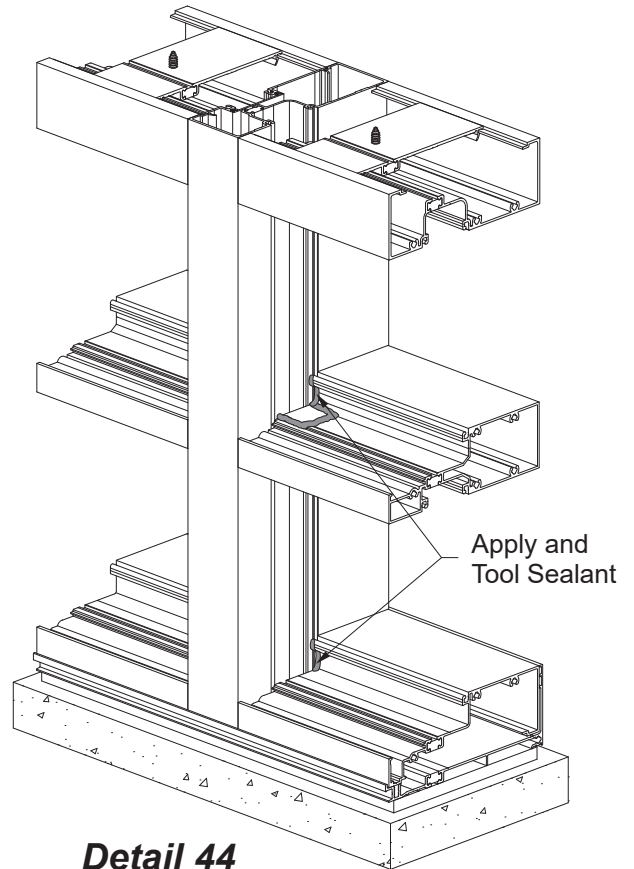

Detail 44

STEP 20 (Optional) INSTALL GLAZING ADAPTORS

Glazing adaptors, E9-1039 and E9-1040, allow for glazing infills other than the standard 1/4" or 1". Please refer to the glazing tables above for possible adaptor/gasket combinations.

- Snap glazing adaptors into the interior gasket reglets of the verticals.
- Snap glazing adaptors into the interior gasket reglets of the horizontals.
- Apply and tool sealant to the joint between vertical and horizontal glazing adaptors.

See **Detail 45**.

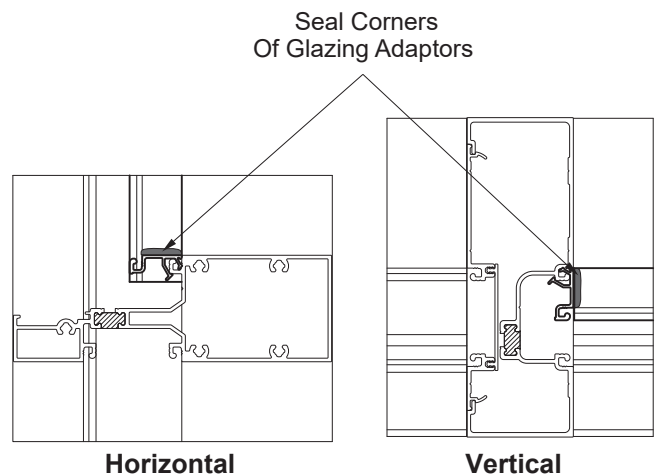

Detail 45

FRAME INSTALLATION

**STEP 21 (Optional)
INSTALL OPTIONAL COMPOUND HORIZONTALS**

-Apply sealant to the top of of the lower horizontals where they intersect with the vertical. Tool the sealant. Do not seal the upper horizontal.

See **Detail 46**.

-Snap the E9-1015 glass stop into the lower horizontal as shown in **Detail 47**. Do not snap glass stops into the upper horizontals yet.

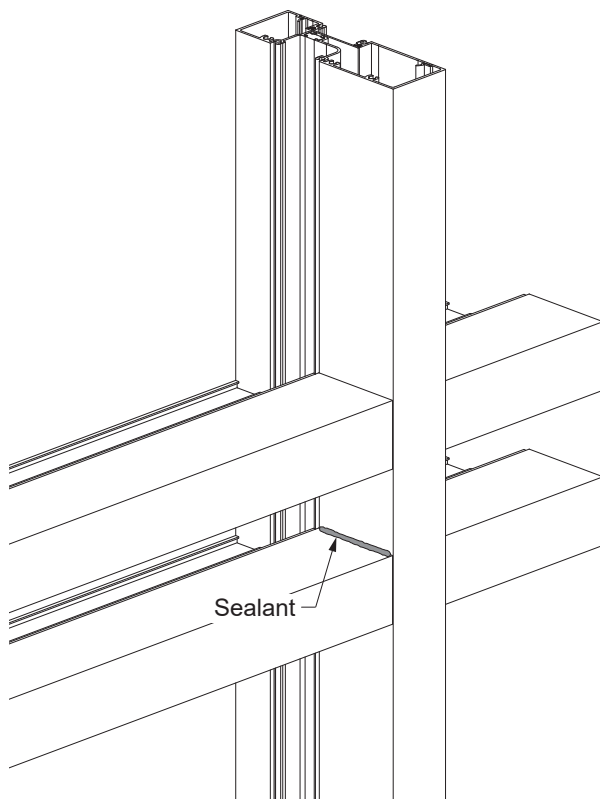

Detail 46

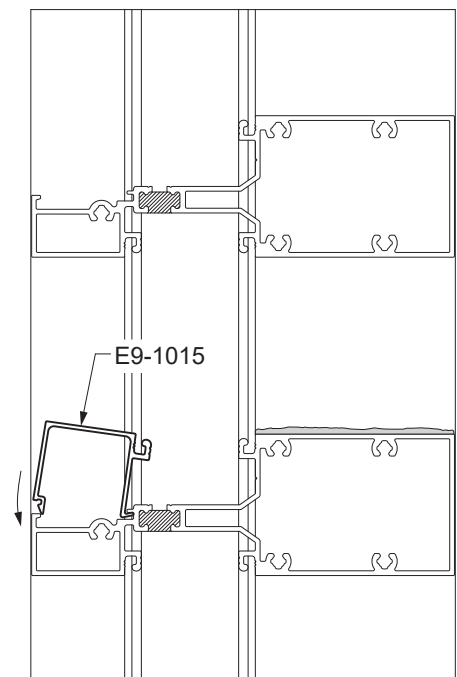

Detail 47

FRAME INSTALLATION

STEP 21 (Optional, Continued) INSTALL OPTIONAL COMPOUND HORIZONTALS

-Snap in the E1-2907 adaptors into the horizontals, one at 3" from each end of each horizontal and one at the middle of each horizontal as shown in **Details 48 & 49**.

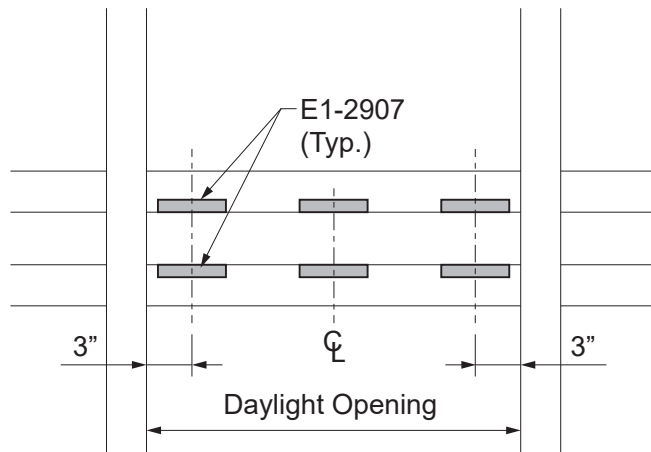

Detail 48

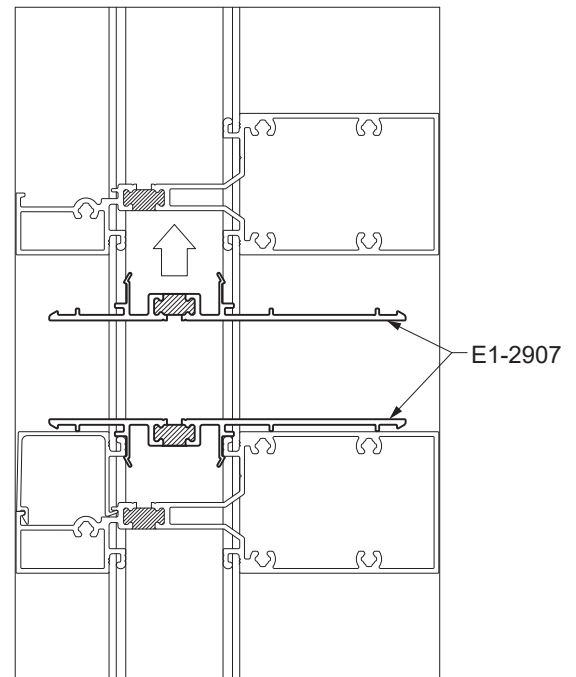

Detail 49

FRAME INSTALLATION

**STEP 21 (Optional, Continued)
INSTALL OPTIONAL COMPOUND HORIZONTALS**

-Cut the front and rear horizontal face covers to Daylight Opening minus(-) 1/16". Apply continuous sealant to the full length of the back of both horizontals where the rear face cover will snap into as shown in **Detail 50**. Snap the rear face cover into place.

-Seal the joint between the edge of the face cover and the verticals as shown in **Detail 51**.

-Snap the front face cover into place.

See **Detail 52**.

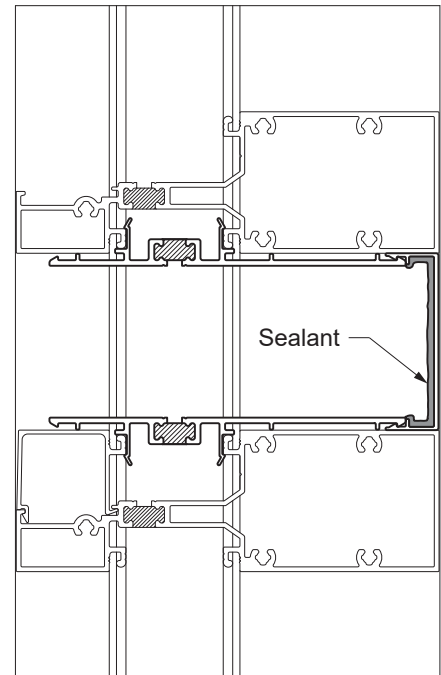

Detail 51

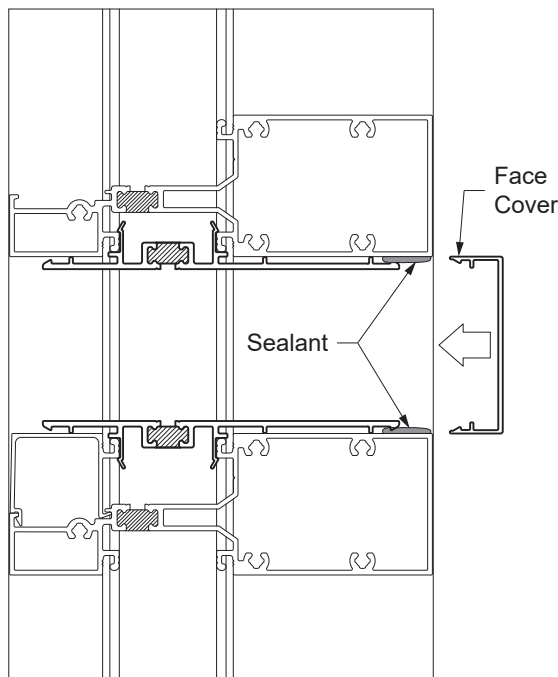

Detail 50

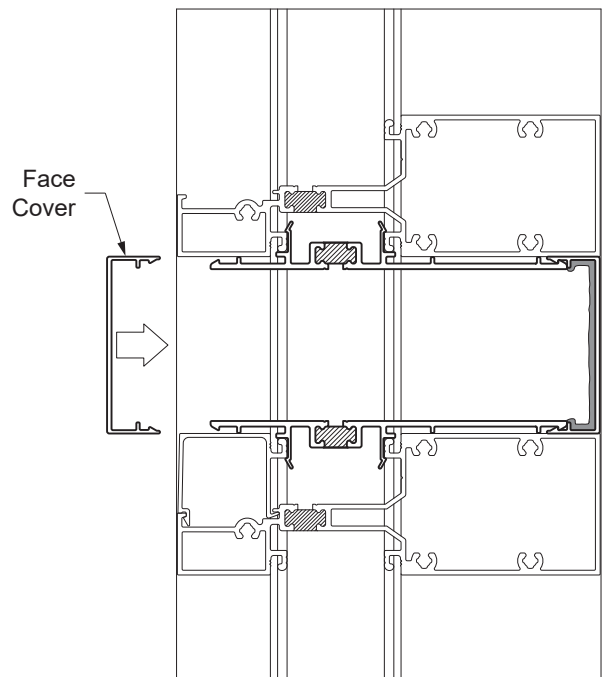

Detail 52

GLAZING

STEP 22 INSTALL INTERIOR GLAZING GASKETS

The interior glazing gaskets must be installed prior to the glazing process.

-Using a small brush clean out any dirt that may have accumulated in the gasket reglets.

Vertical glazing gaskets must be installed first:

- Cut vertical glazing gaskets to Daylight Opening plus(+) 1/4" for each foot of length.
- Insert the gasket into the reglet at each end first, and then insert the gasket at the midpoint of the opening.
- Push the gasket into the reglet starting at the midpoint and work towards each end.

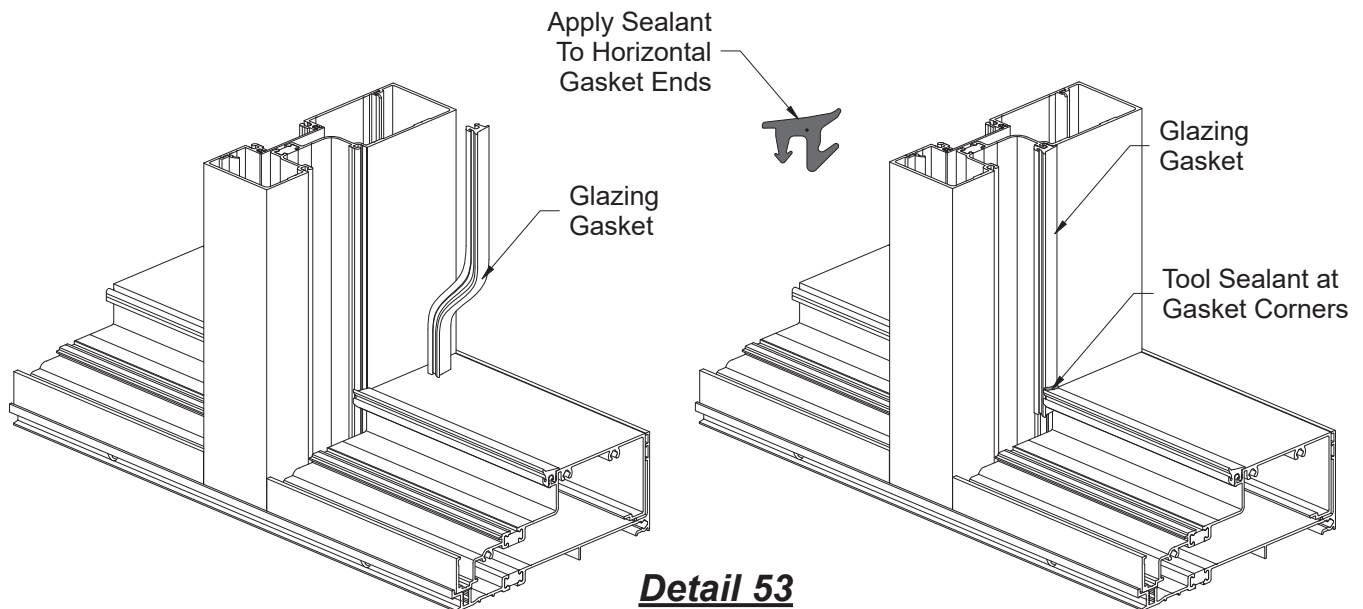

Install horizontal glazing gaskets next:

- Cut horizontal glazing gaskets to Daylight Opening plus(+) 1/4" for each foot of length.
- Apply sealant to each end of the horizontal glazing gasket prior to inserting into the reglet.
- Insert the gasket into the reglet at each end first and push each end tight against the vertical gasket.
- Then insert the gasket at the midpoint of the opening and push the gasket into the reglet starting at the midpoint and work towards each end.
- Tool the excess sealant at the gasket corners to ensure a watertight seal.

See **Detail 53**.

GLAZING

**STEP 23
INSTALL GLASS**

Determine the glass size:

Horizontal Glass Size = D.L.O. plus(+) 3/4"
Vertical Glass Size = D.L.O. plus(+) 3/4"

- Carefully install the glass into the opening: insert the leading edge of the lite up and into the deep pocket first and then rotate the trailing edge in place.
- Carefully lift lite of glass, install setting blocks at quarter points of horizontal D.L.O. or according to engineering calculations.
- Make sure the glass is properly positioned on all setting blocks.

See **Detail 54**.

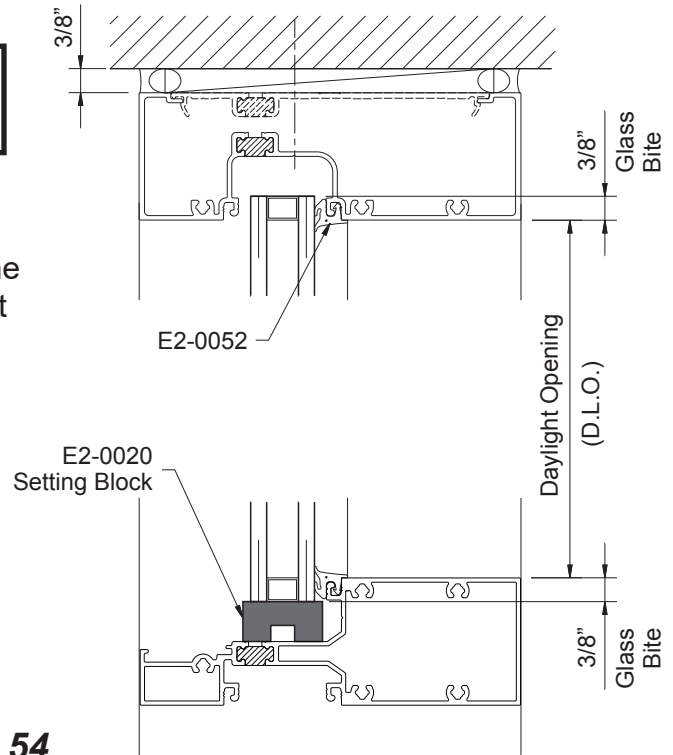

Detail 54
 YES 60 TU shown,
 YES 60 FI similar

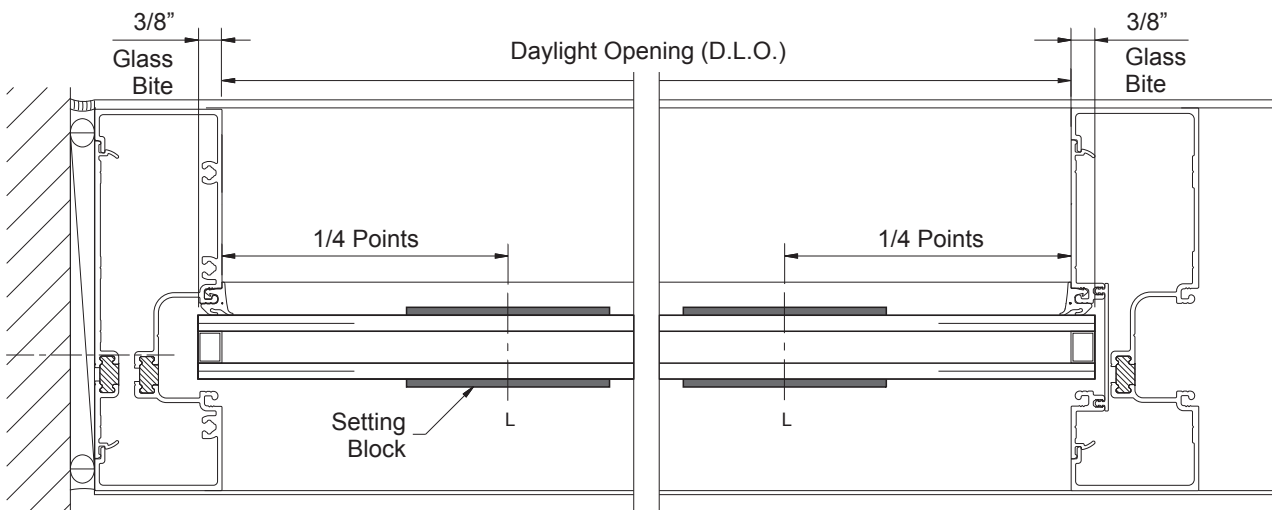

GLAZING

STEP 24 INSTALL ANTI-WALK BLOCKS

YES 60 FI and TU frames require the installation of an anti-walk block, E2-0153, in the deep mullion glazing pocket of each lite centered on the daylight opening.

-Flatten the anti-walk block against the exterior surface of the glass and push it into the opening between the glass and the mullion until it is released into the glazing pocket.

See **Detail 55**.

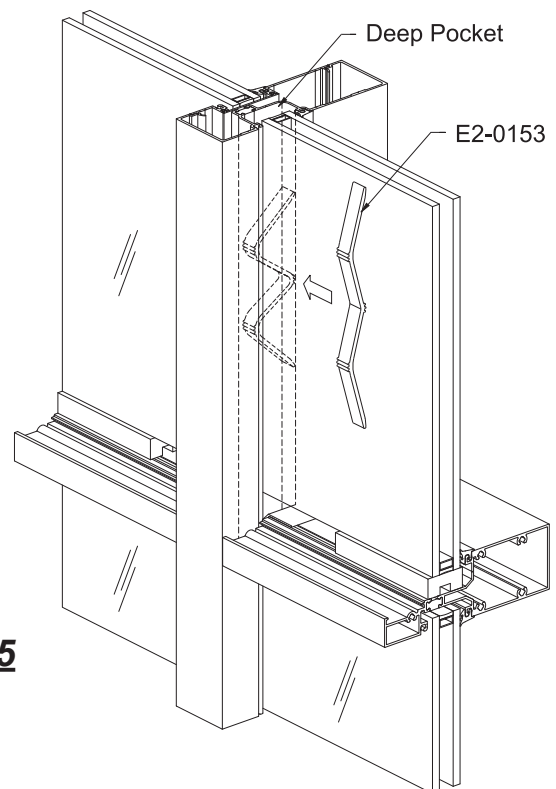
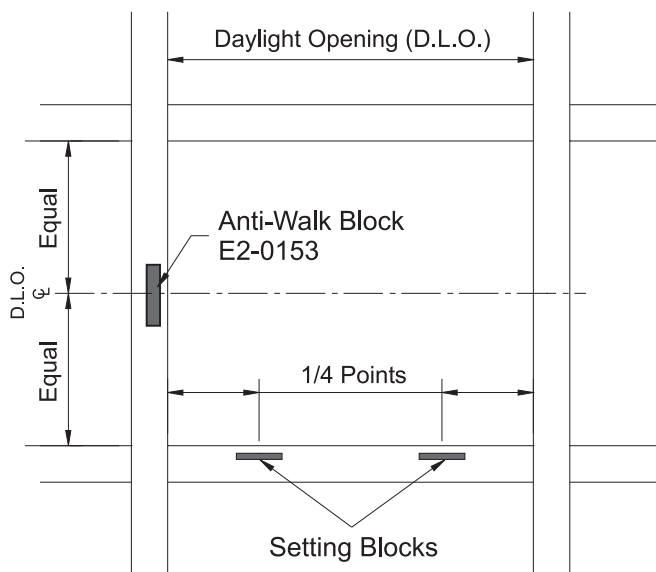

Detail 55

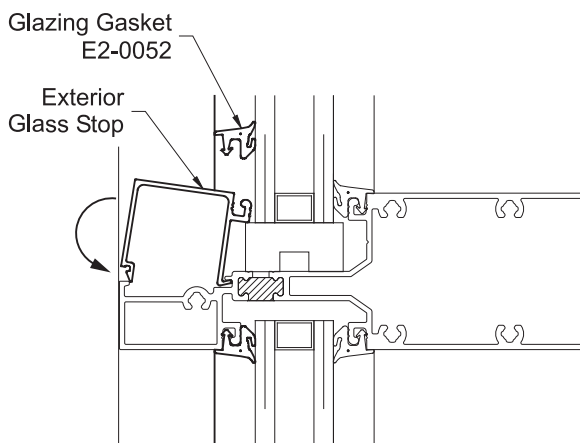

Detail 56

YES 60 TU shown,
YES 60 FI similar

STEP 25 INSTALL EXTERIOR GLASS STOPS & GLAZING GASKETS

-Snap the exterior glass stops into place as shown in **Detail 56**.

-Install the exterior glazing gaskets using the same technique described in **Step 22** on **Page 35**. Always install the vertical glazing gasket first.

Repeat **Steps 22 through 25** until all lites are installed.



101 Marietta Street NW
Suite 2100
Atlanta, Georgia 30303
www.ykkap.com