

YWW 50 TU / YWW 60 TU Window Wall Installation Manual Preglazed SSG

This instruction set is for the new sill flashing cover.
Please verify ordered material before proceeding.

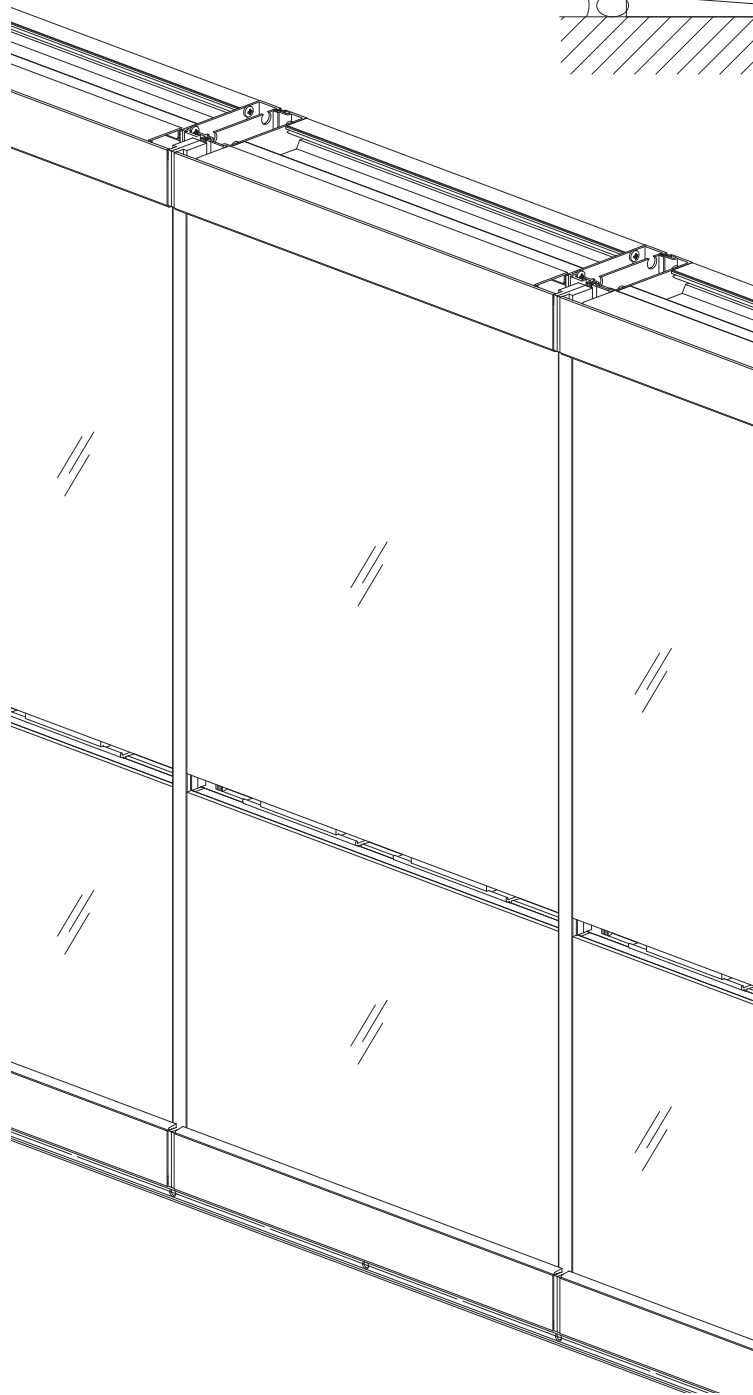
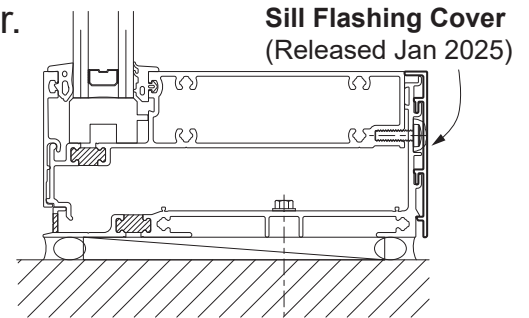

This page intentionally left blank.

TABLE OF CONTENTS

Installation Notes.....	Page ii
Important Notice.....	Page iii
PARTS DESCRIPTION	
Framing Members.....	Pages 1 to 4
Accessories.....	Pages 5 to 7
FRAME FABRICATION	
Determine Frame Size.....	Pages 8 & 9
Fabricate Vertical Members.....	Pages 10 & 11
Fabricate Horizontals.....	Pages 12 to 14
Fabricate Fillers & Glass Stops.....	Page 15
Fabricate Sill Flashing.....	Page 16
Fabricate Slab Edge Plate Adaptor.....	Page 17
Fabricate Corner Covers.....	Page 17
Fabricate Head Receptors.....	Page 18
FRAME ASSEMBLY	
Assemble Frame.....	Pages 19 to 23
Install Steel Reinforcing (Optional).....	Page 24
Install Perimeter Fillers.....	Page 25
Install Foam Plugs at Head.....	Page 26
Install Weather Seal.....	Page 27
Install Exterior Glazing Gaskets.....	Pages 28 to 29
GLAZING	
Install Setting/Side Blocks.....	Page 30
Install Glass.....	Pages 31 to 33
Seal Glass to Frame.....	Page 34
Install Glass Stops.....	Pages 35 & 36
Install SSG Rainscreen Gasket.....	Page 37
Install Exterior Wedge Gaskets.....	Pages 38 & 39
Install Joint Plugs.....	Page 40
FRAME INSTALLATION	
Install Sill Flashing End Dams.....	Page 41 & 42
Install Sill Flashing.....	Page 43
Install Flashing Splice Sleeve.....	Pages 43 & 44
Install Slab Edge Covers.....	Pages 45 to 52
Install Sill Flashing at Corners.....	Pages 53 & 54
Install Frames.....	Pages 55 to 59
Apply Perimeter Sealant.....	Pages 60 to 62
Install Interior Covers.....	Page 63

Installation Notes

1. Do not drop, roll or drag boxes of aluminum framing. Move and stack boxes with proper support to prevent distortion. If fork lifts are used, be especially careful about striking the boxes when lifting or moving.
2. Store in a dry, out of the way area. If rain exposure, condensation or any water contact is likely, then all packaging material should be removed. Wet packaging materials will discolor and may stain aluminum finishes and paints.
3. All materials should be checked for quality and quantity upon receipt, YKK AP must be notified immediately of any discrepancies in shipment. Check to make sure that you have the required shims, sealants, supplies and tools necessary for the installation.
4. Carefully check the openings and surrounding conditions that will receive your material. Remember, if the construction is not per the construction documents, it is your responsibility to notify the general contractor in writing. Any discrepancies must be brought to the general contractor's attention before you proceed with the installation.
5. Gather your shop drawings, materials, packing list, and this installation manual. Carefully review parts location, the sequence it goes therein, when you glaze it and how you seal it. Installation instructions are of a general nature and may not cover every condition you will encounter. The shop drawings and/or installation manuals were prepared specifically for the product.
6. Any material substitutions must be of equal or greater quality.
7. Make certain that material samples have been sent for compatibility testing for all manufacturer's sealants involved. Make certain sealants have been installed in strict accordance with the manufacturer's recommendations and specifications.
8. Remember to isolate, in an approved manner, all aluminum from uncured masonry or other incompatible materials.
9. System-to-structure fasteners are not supplied by YKK AP. Fasteners called out on shop drawings are to indicate minimum sizes for design loading.
10. If any questions arise concerning YKK AP products or their installation, contact YKK AP for clarification before proceeding.
11. YKK AP storefront and/or curtain wall framing is typically completed before drywall, flooring and other products which may still be in process. Take the extra time to wrap and protect the work produced.
12. Cutting tolerances are plus zero, minus one thirty second unless otherwise noted.
13. Check our website, www.ykkap.com, for the latest installation manual update prior to commencing work.

Important Notice for SSG Window Wall Systems:

In order to properly perform and to maintain structural integrity, in addition to all other installation requirements, structurally glazed window wall systems rely specifically upon effective and appropriate structural sealant selection and installation.

It is the responsibility of the glazing contractor to take all steps to ensure the installed structural sealant is capable of meeting all applicable project requirements in accordance with industry standards. Such steps on each project may include, but are not limited to, design reviews, formal adhesion testing, project specification compliance, validating applications, field testing, auditing, sealant design strength analysis, and the quality control review of the installation and surrounding conditions.

Subject to project specific design pressures, requirements, and/or specifications, the structural sealant that is used between the glass and framing system must be capable of withstanding tensile and shear stresses imposed by the window wall without failing adhesively or cohesively.











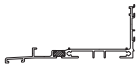







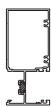

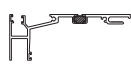
The structural sealant's capability to withstand these stresses are dependent on several factors including, but not limited to, type of structural sealant, method of application (i.e. cleaning, primer), construction of glazing material (i.e. insulating glass unit (IGU), other infill, and finish of framing (i.e. anodizing, paint).

- Adhesive failure occurs when sealant pulls away from substrate cleanly, leaving no sealant material behind.
- Cohesive failure occurs when sealant breaks or tears within itself but does not separate from each substrate because sealant-to-substrate bond strength exceeds sealant's internal strength.

The IGU and/or other infill must be constructed for installation into structurally sealant glazed window walls. Notify the manufacturer or fabricator of the IGU and/or infill and advise of the product's application into 2 or 4-sided structurally sealant glazed window walls along with the project's design requirements so that appropriate fabrication steps are taken.

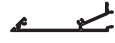
This page intentionally left blank.

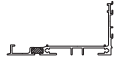
YWW 50TU FRAMING MEMBERS

	Male Mullion	BE9-2764		Sill Flashing for Slab Edge Cover	BE9-2846
	Female Mullion	BE9-2765		Sill Flashing Interior Cover Used with BE9-2845 & BE9-2846	E9-2868
	Female SSG Mullion	E9-2768		Deep Sill Flashing Interior Cover Used with BE9-2845 & BE9-2846	E9-2869
	Male SSG Mullion	E9-2769		Strap Anchor Used with BE9-2845 & BE9-2846	E9-2847
	Jamb 2-1/4" x 5"	BE9-2766		Head Receptor	BE9-7635
	Tubular Jamb 2-1/4" x 5"	BE9-2790		Optional Head Receptor	BY7-8426
	Corner Mullion Half 2-1/4" x 5"	BE9-2779		Head Receptor w/ Plate Adaptor	BE9-2819
	Head (OG) 2-1/2" x 5"	BE9-2771		Receptor Snap Cover Used with BE9-7635	E9-8720
	Horizontal (OG)	BE9-2789		Receptor Snap Cover Used with BE9-2819	E9-8157
	SSG Horizontal	E9-2770		90° Corner Cover (Large)	E9-2783
	Sill (OG)	BE9-2843		90° Corner Cover (Small)	E9-2741
	Sill Flashing	BE9-2845		135° Corner Cover (Large)	E9-2784











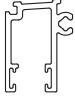
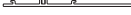



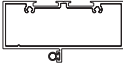

YWW 50 TU FRAMING MEMBERS

	135° Corner Cover (Small) E9-2743		9" Slab Edge Cover For Use with 8" Slab E9-8428
	Flush Filler E9-2780		Anchor E9-2732
	Exterior Glass Stop E9-1715		Door Jamb Adaptor Subframe For 20D/35D/50D Doors Use with AS-0417 E9-2344
	Aluminum Plate Adaptor For BE9-2735 E9-8222		4-1/2" x 1-3/4" Door Head For 20D/35D/50D Doors E2-0051 Included AS-0402
	6-1/8" Slab Edge Cover For Use with 5-1/8" Slab E9-8059		Door Stop For 20D/35D/50D Doors E2-0051 Included Use with E9-2344 AS-0417
	6-5/8" Slab Edge Cover For Use with 5-5/8" Slab E9-7723		Flat Filler Use with BE9-2765 BY7-9241
	7-3/8" Slab Edge Cover For Use with 6-3/8" Slab E9-8223		Door Jamb Adaptor Subframe For 25T/35T/50T Doors Use with AS-1539 BE9-1526
	7-7/8" Slab Edge Cover For Use with 7-7/8" Slab E9-8231		Door Head Subframe For 25T/35T/50T Doors E2-0051 Not Included BE9-2582
	8" Slab Edge Cover For Use with 7" Slab E9-8589		Door Stop For 25T/35T/50T Doors E2-0051 Included Use with BE9-1526 AS-1539



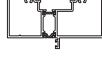









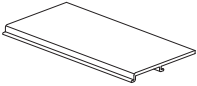

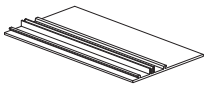
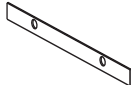
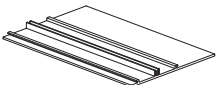
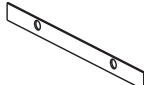

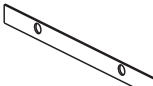

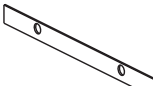

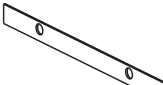
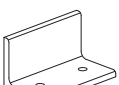
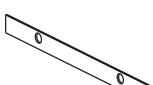
YWW 60 TU FRAMING MEMBERS

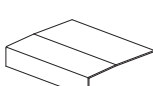
	Female Mullion	BE9-2746		Sill Flashing for Slab Edge Cover	BE9-2866
	Male Mullion	BE9-2747		Sill Flashing Interior Cover Used with BE9-2845 & BE9-2846	E9-2868
	Female SSG Mullion	E9-2750		Deep Sill Flashing Interior Cover Used with BE9-2845 & BE9-2846	E9-2869
	Male SSG Mullion	E9-2751		Head Receptor	BE9-7736
	Jamb 2-1/4" x 6"	BE9-2748		Head Receptor w/ Plate Adaptor	BE9-7299
	Tubular Jamb 2-1/4" x 6"	BE9-2793		HD Receptor Snap Cover Used with BE9-7736 & BE9-7299	E9-8157
	Corner Mullion Half 2-1/4" x 6"	BE9-2761		90° Corner Cover (Large)	E9-2740
	Head (OG) 2-1/2" x 6"	BE9-2753		90° Corner Cover (Small)	E9-2741
	Horizontal (OG)	BE9-2792		135° Corner Cover (Large)	E9-2784
	SSG Horizontal Mullion	E9-2752		135° Corner Cover (Small)	E9-2743
	Sill (OG)	BE9-2863		Flush Filler	E9-2762
	Sill Flashing	BE9-2865		Exterior Glass Stop	E9-1715

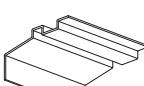

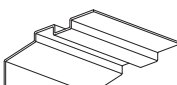



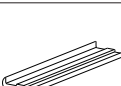



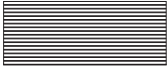











YWW 60 TU FRAMING MEMBERS

	<p>Aluminum Plate Adaptor For BE9-2735</p>	<p>E9-8222</p>		<p>Strap Anchor Used with BE9-2865 & BE9-2866</p> <p>E9-2867</p>
	<p>6-1/8" Slab Edge Cover For Use with 5-1/8" Slab</p>	<p>E9-8059</p>		<p>Door Jamb Adaptor Subframe For 20D/35D/50D Doors Use with AS-0417</p> <p>E9-2344</p>
	<p>6-5/8" Slab Edge Cover For Use with 5-5/8" Slab</p>	<p>E9-7723</p>		<p>4-1/2" x 1-3/4" Door Head For 20D/35D/50D Doors E2-0051 Included</p> <p>AS-0402</p>
	<p>7-3/8" Slab Edge Cover For Use with 6-3/8" Slab</p>	<p>E9-8223</p>		<p>Door Stop For 20D/35D/50D Doors E2-0051 Included Use with E9-2344</p> <p>AS-0417</p>
	<p>7-7/8" Slab Edge Cover For Use with 7-7/8" Slab</p>	<p>E9-8231</p>		<p>Flat Filler</p> <p>BY7-9241</p>
	<p>8" Slab Edge Cover For Use with 7" Slab</p>	<p>E9-8589</p>		<p>Door Jamb Adaptor Subframe For 25T/35T/50T Doors Use with AS-1539</p> <p>BE9-1526</p>
	<p>9" Slab Edge Cover For Use with 8" Slab</p>	<p>E9-8428</p>		<p>Door Head Subframe For 25T/35T/50T Doors E2-0051 Not Included</p> <p>BE9-2582</p>
	<p>Head Anchor</p>	<p>E9-2732</p>		<p>Door Stop For 25T/35T/50T Doors E2-0051 Included Use with BE9-1526</p> <p>AS-1539</p>
	<p>Strap Anchor For YWW 60 TU</p>	<p>E9-2733</p>		

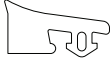
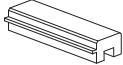
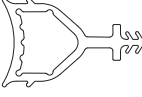



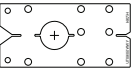

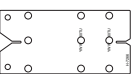
ACCESSORIES

	Head Anchor 10" Cut Length	E1-1190		End Cap (YWW 60 TU) For BE9-7299 Slab Edge Head Receptor	E1-9822
	Strap Anchor 10" Cut Length For YWW 60 TU	E1-1191		End Cap For Slab Edge Sill Flashing Adaptor	E1-1196
	Sill Strap Anchor 10" Cut Length For YWW 50 TU	E1-2853		End Cap For E9-8059 Slab Edge Cover Plate	E1-9984
	Sill Strap Anchor 10" Cut Length For YWW 60 TU	E1-2854		End Cap For E9-7723 Slab Edge Cover Plate	E1-9985
	Jamb Strap Anchor 4" Cut Length For YWW 50 TU	E1-1143		End Cap For E9-8223 Slab Edge Cover Plate	E1-9953
	Jamb Strap Anchor 4" Cut Length For YWW 60 TU	E1-1149		End Cap For E9-8231 Slab Edge Cover Plate	E1-9954
	Door Jamb Mullion Anchor (1-7/8")	E1-1195		End Cap For E9-8589 Slab Edge Cover Plate	E1-9955
	Door Jamb Anchor (3-5/8")	E1-1199		End Cap For E9-8428 Slab Edge Cover Plate	E1-9956
	End Dam For YWW 50 TU Sill Flashing	E1-2851		Splice Sleeve For Sill Flashing at Slab Edge	E1-2855
	End Dam For YWW 60 TU Sill Flashing	E1-2852		Head Receptor Splice Sleeve For YWW 50 T	E1-2813
	End Cap (YWW 50 TU) For BE9-7635 & BY7-8426 Head Receptor	E1-9841		Head Receptor Splice Sleeve For YWW 60 T	E1-9824
	End Cap (YWW 50 TU) For BE9-2819 Slab Edge Head Receptor	E1-9952		Head Receptor Splice Sleeve For Slab Edge	E1-9961
	End Cap (YWW 60 TU) For BE9-7736 Head Receptor	E1-9855		Setting Block Chair	E1-3545

ACCESSORIES (Continued)

	Silicone Splice Sleeve	E2-0070		Setting Block For Slab Edge Cover	E2-0054
	Flat Filler PVC For YWW 50 TU	E3-0032		Water Deflector	E2-0047
	Flat Filler PVC For YWW 60 TU	E3-0023		SSG Joint Plug	E2-9802
	PVC Perimeter/Pocket Filler	E3-3664		Foam Backer Tape 1" x 1-1/4" (Roll)	E2-0259
	Airtight Gasket	E2-0051		1/4" x 1/4" Spacer Tape	E2-0110
	Weather Seal Gasket For Mullion Halves	E2-7010		Dart Gasket (Silicone) 1/4" F.C.	E2-0541
	Weathering Gasket For Slab Edge Cover	E2-0065		Wedge Gasket (Silicone) 1/4" F.C.	E2-0542
	Anti-Walk Block For Female Mullion	E2-0546		SSG Spacer For Verticals	E2-0544
	Side Block For Male Mullion	E2-0133		SSG Spacer For Horizontals	E2-7001
	Setting Block	E2-0150		SSG Rainscreen Gasket	E2-0540
	SSG Setting Block	E2-0224		Weep Baffle	E2-0099
	Setting Block For Jamb	E2-0628		Drill Fixture	H-7264
	Setting Block for Intermediate Horizontals	E2-0178		Drill Fixture For Sill	H-7266

FASTENERS

	<p>#10" x 3/8" PHMS Stainless Steel, For Corner Cover Attachment</p>	<p>PM-1006 -SS</p>		<p>#12 x 5/8" PHSMS Type AB, Zinc Plated Steel</p> <p>PC-1210</p>
	<p>#12 x 3/4" UFHSMS Type A, Zinc Plated Steel, For End Dam Attachment</p>	<p>UA-1212</p>		<p>#12 x 1-1/4" PHSMS Type AB, Zinc Plated Steel</p> <p>PC-1220</p>
	<p>#12 x 1" FHSMS Type AB, Used with Jamb Strap Anchor</p>	<p>FC-1216</p>		<p>#10 x 5/8" PHMS For Attachment of Sill to Sill Flashing</p> <p>PM-1010</p>

FRAME FABRICATION

STEP 1 DETERMINE FRAME SIZE

Determine Frame Width:

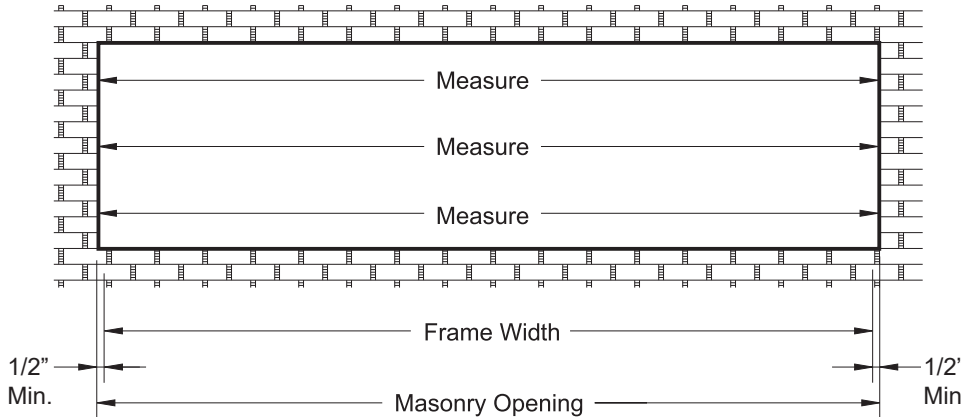

Note: Check opening for squareness of plumb at both ends, units must be installed in a true rectangle.

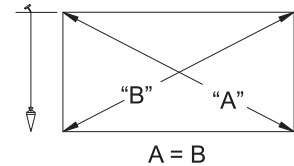

DETAIL 1

- Measure the width of the masonry opening at the top, middle, and bottom.
 - Select the smallest dimension measured and subtract 1" to determine the frame width.
- See **Detail 1**.

Note: For additional possibilities such as slab edge cover application, it is recommended to increase the caulk joint at the jambs to facilitate installation of the last framed unit. (Unit width will proportionally affect caulk joint width.)

Determine Frame Height:

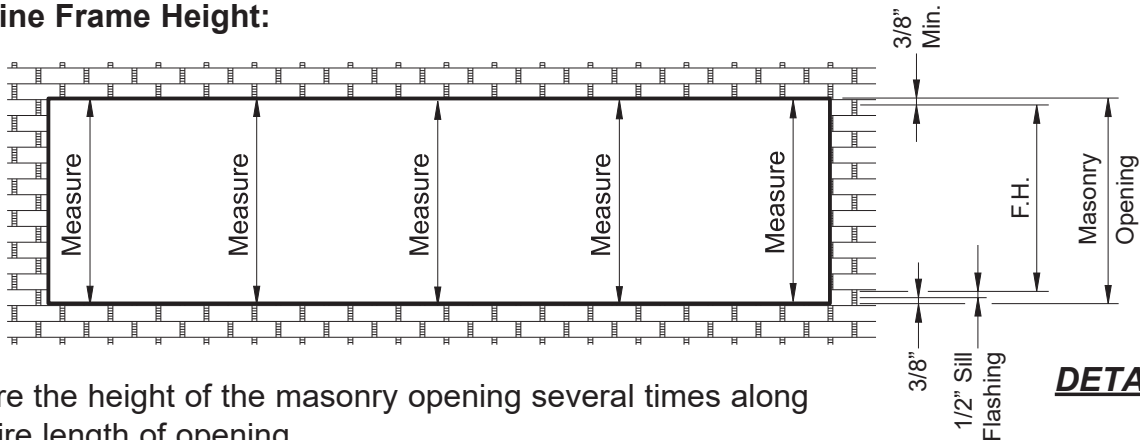

DETAIL 2

- Measure the height of the masonry opening several times along the entire length of opening.
- Select the smallest dimension measured and subtract *1-1/4" to determine the frame height to be used.

Minimum of 3/8" shim/caulk joint at the head.

1/2" for the sill flashing.

Minimum 3/8" shim/caulk joint below the sill flashing.

See **Detail 2**.

* **Note:** 1-1/4" is based on 3/8" perimeter caulk joint, which can vary per project.

FRAME FABRICATION

STEP 1 (Continued)
DETERMINE FRAME SIZE

Determine Frame Height for Slab Edge Conditions:

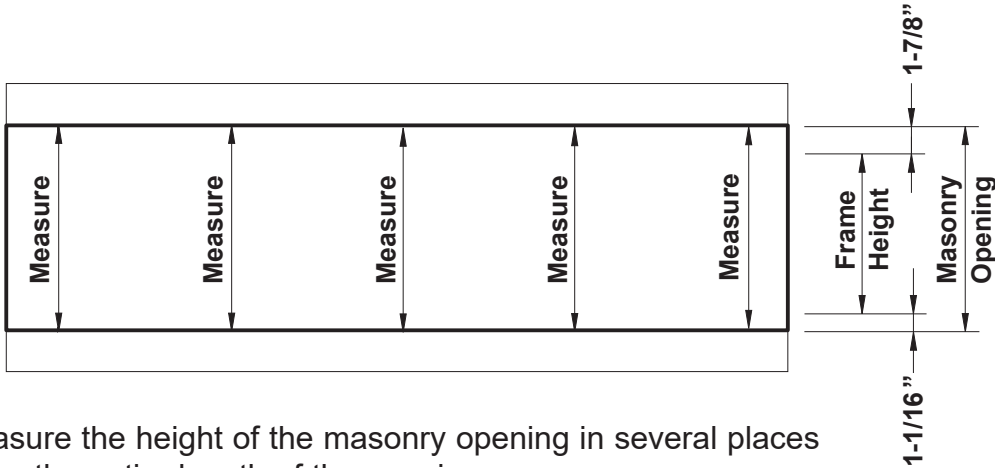

- Measure the height of the masonry opening in several places along the entire length of the opening.
- Select the smallest dimension measured and subtract *3" to determine the frame height to be used:
 - 5/8" for the shim/caulk joint at the head.
 - 1-1/4" for the head receptor.
 - 1/2" for the sill flashing.
 - 5/8" for the shim/caulk joint below the sill flashing.

Detail 3

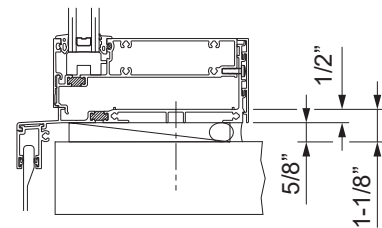
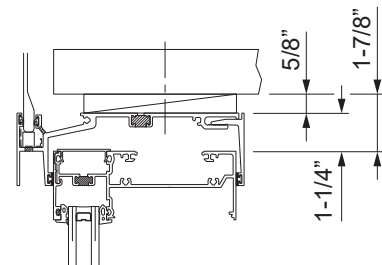

See **Detail 3**.

* **Note:** 3" is based on 5/8" perimeter caulk joint, which can vary per project.

FRAME FABRICATION

STEP 2 FABRICATE VERTICAL MEMBERS

- Cut all jamb and two piece vertical members to the frame height determined in **Step 1**.
- Fabricate holes in the vertical members for screw spline attachment using one of the methods below:
 - Using the H-7264 and H-7266 drill fixture as a template, line up the glazing pockets and mark hole locations through the screw splines of the templates.
 - OR**
 - Layout hole locations on vertical members as shown in **Detail 4**.
- Drill 0.236" diameter (#B drill bit) holes at each location marked.

Notes: Additional fabrication will be required for the inclusion of steel reinforcing. Drill fixture plate can be used.

* A 5/16" diameter access hole can be used at the very top to eliminate sharp edges.

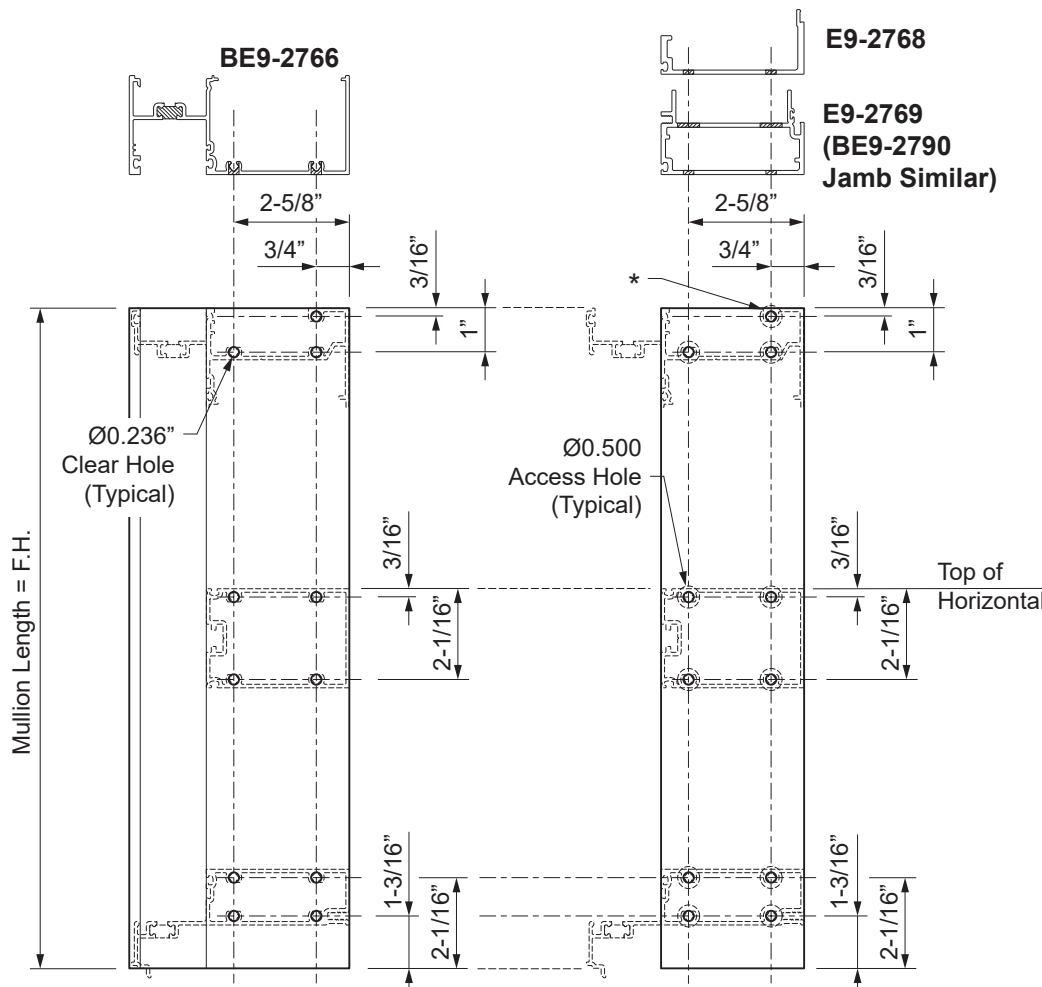

Detail 4

FRAME FABRICATION

**STEP 2 (Continued)
FABRICATE VERTICAL MEMBERS**

-For hollow vertical members, fabricate access holes in addition to the clear holes according to the methods previously shown and in **Detail 5**.

Notes: Additional fabrication will be required for the inclusion of steel reinforcing.

* A 5/16" diameter access hole can be used at the very top to eliminate sharp edges.

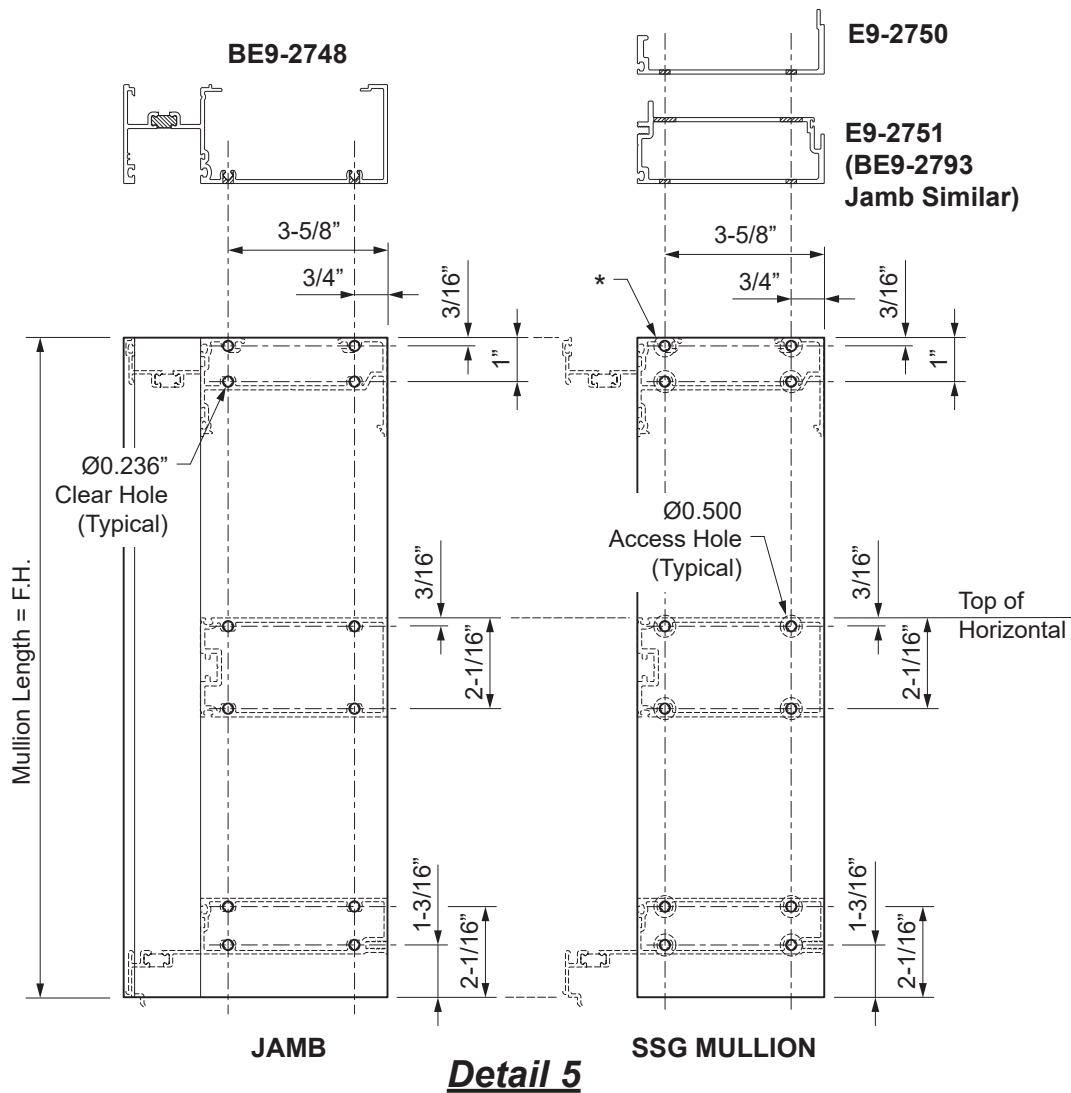

FRAME FABRICATION

**STEP 3
FABRICATE HORIZONTALS**

- Cut all SSG horizontals to the horizontal daylight opening.
- Cut all head and sill members to the horizontal daylight opening plus(+) the numbers as shown in **Details 6 & 7**.

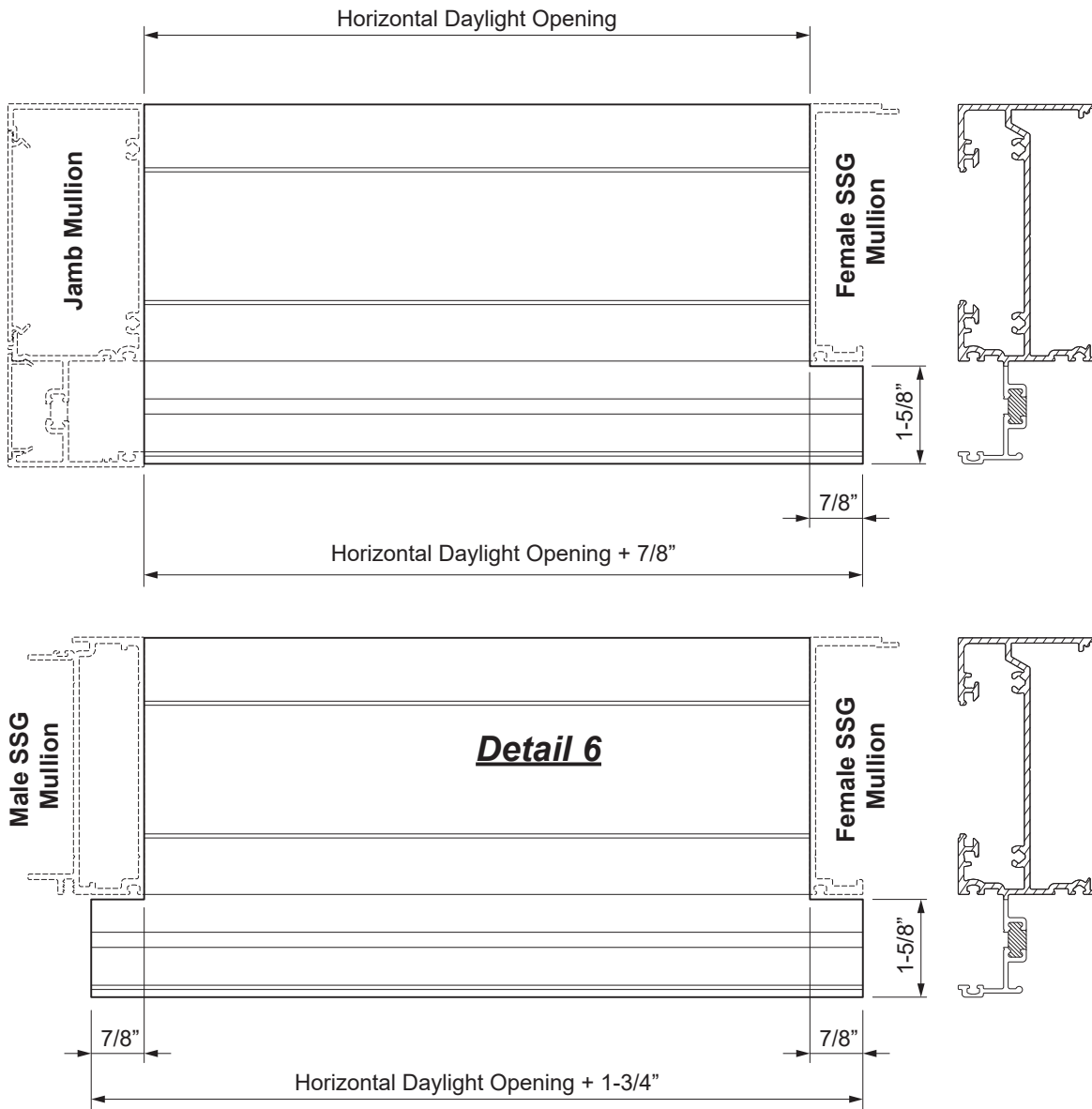

FRAME FABRICATION

STEP 3 (Continued)
FABRICATE HORIZONTALS

-Sill members will require 0.313" (5/16") weep holes through the glazing pocket at 1/3 points of the Daylight Opening; and 0.500" diameter drain holes, located along the "V" Groove at the underside as shown in **Detail 7**.

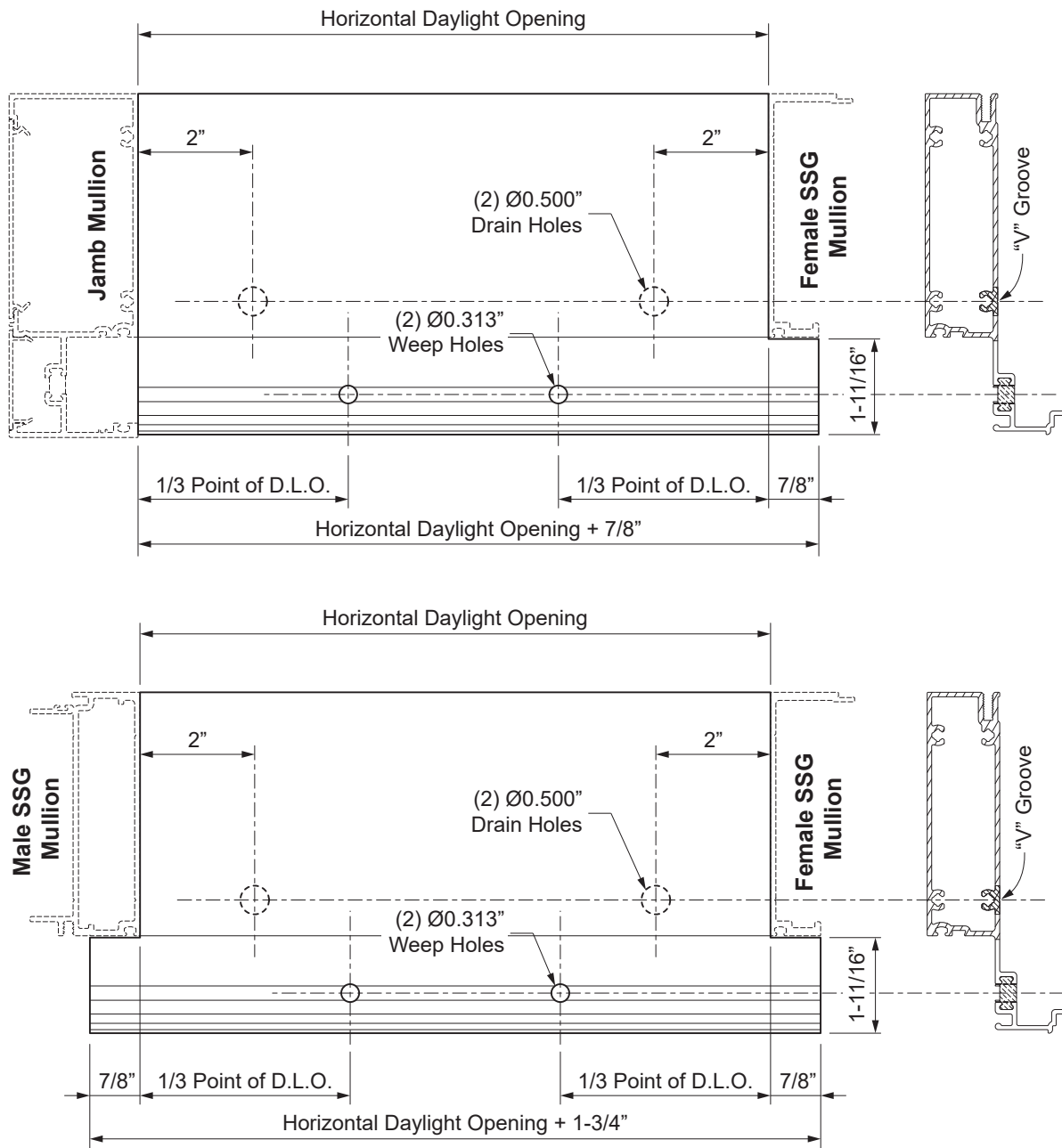

Detail 7

FRAME FABRICATION

**STEP 3 (Continued)
FABRICATE HORIZONTALS**

When the head is anchored to the substrate with the E1-1190 anchor, access holes will need to be drilled into the head member.

- Temporarily clamp the E1-1190 anchor onto the head where it will be in relation to the head member once anchored to the substrate.
- Drill 5/16" diameter holes into the head in line with the holes in the anchor. Unclamp the anchor. Then drill the access holes out to 3/4" diameter.

Notes: This is in addition to the 0.189" diameter tap holes for the glass stop. Refer to FPA drawings or shop drawings for appropriate fastener and hole locations as determined by a qualified engineer.

See **Detail 8**.

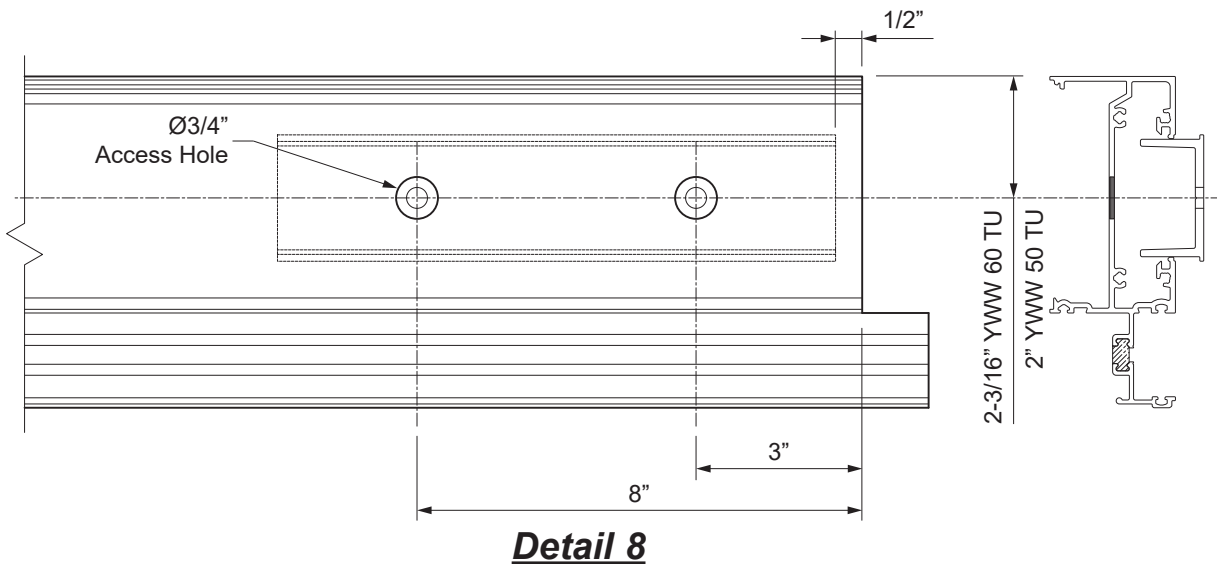

FRAME FABRICATION

**STEP 4
FABRICATE FILLERS & GLASS STOPS**

- Cut all vertical perimeter PVC flat fillers to the length of the jambs, except where strap anchors would interfere with the jamb filler.
- Cut all horizontal flush fillers and flat fillers to horizontal daylight opening minus(-) 1/32".

See **Detail 9**.

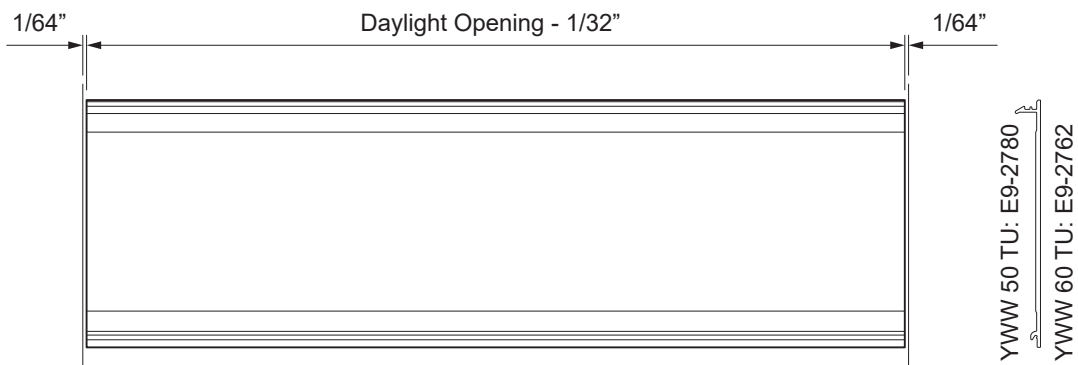

Detail 9

- Cut E9-1715 exterior glass stops to the dimensions shown below in **Detail 10**.

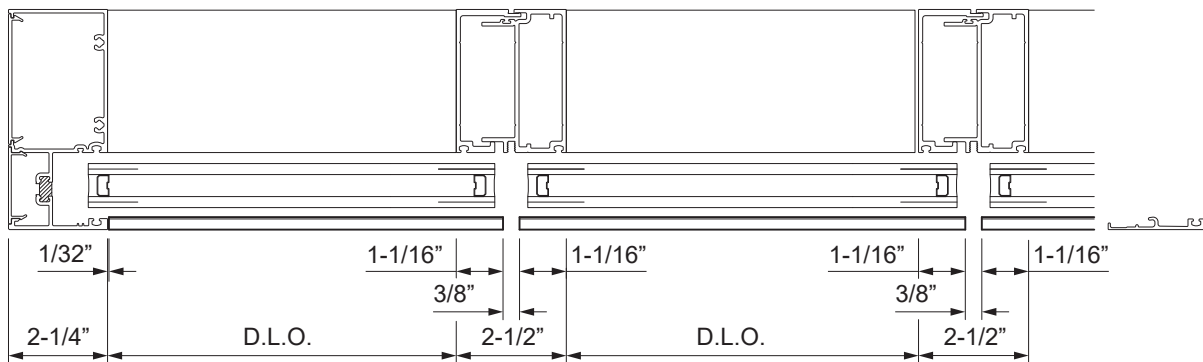

Detail 10

FRAME FABRICATION

STEP 5 FABRICATE SILL FLASHING

- Cut the sill flashing to the frame width plus(+) 5/16" at each jamb.
- Cut the E9-2868 interior cover to the same dimension as the sill flashing.
- Note:** For additional possibilities such as slab edge cover application, it is recommended to provide additional space between the edge of the sill flashing and the jamb substrate.
- For frame openings longer than 24'-0", allow for a 3/8" splice joint between sill flashing members every twelve to fifteen feet at the center of a daylight opening.
- Mark the front face of the sill flashing at the center of each vertical location and the midpoint of the daylight opening between the verticals.
- Drill a Ø5/16" weep hole in the face of the sill flashing at each location marked.
- Also, drill a Ø0.213" clear hole in the back of the sill flashing at each location marked.

See **Detail 11**.

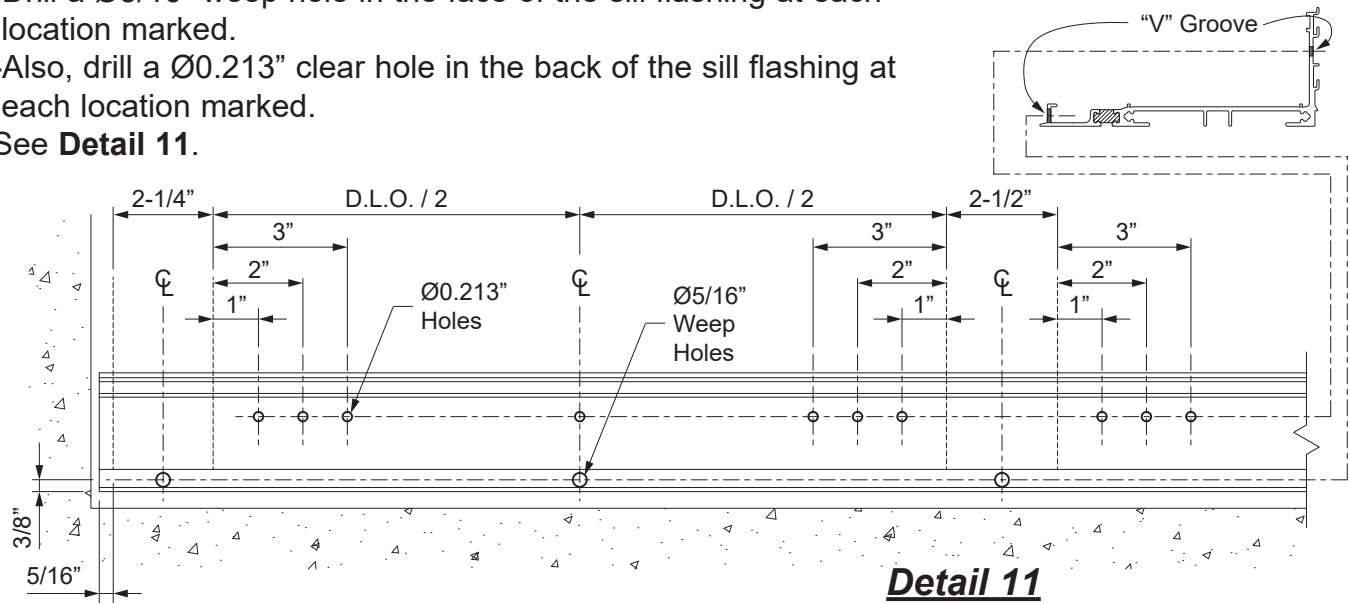

Additional fabrication will be required for BE9-2846 and BE9-2866 sill flashings used at slab edge covers if splices are needed.

- Notch the sill flashing as shown in **Detail 12**.

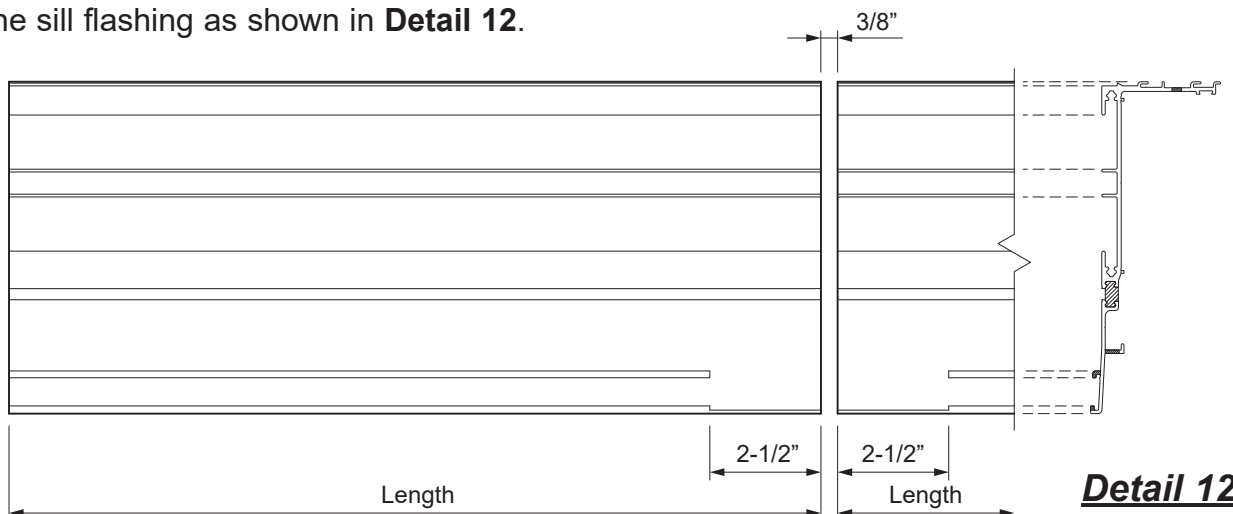

FRAME FABRICATION

**STEP 5A
FABRICATE SLAB EDGE PLATE ADAPTOR**

- Cut the aluminum plate adaptor E9-8222 to the same length as the sill flashing.
- Notch the aluminum plate adaptor 2-1/2" from each end at each splice joint location as shown in **Detail 13**.
- Cut slab edge cover plates to length as indicated on the approved shop drawings

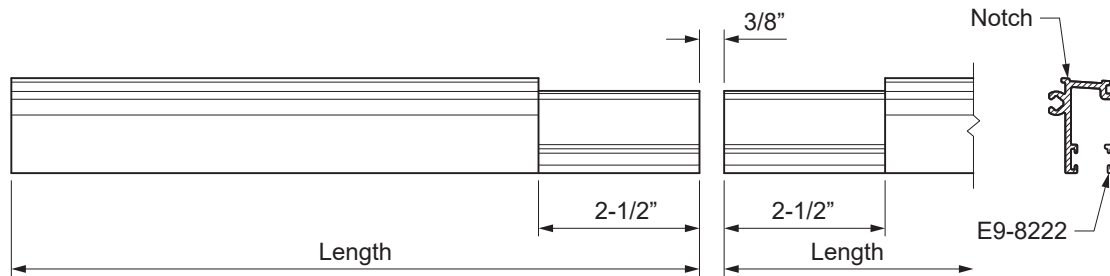

Detail 13

**STEP 6
FABRICATE CORNER COVERS**

- Cut the corner cover components to the mullion length. Drill 0.213" diameter holes into the cover at the v-groove where the cover will be fastened to the mullion at 3" from each end and at 24" maximum on center.

See **Detail 14**.

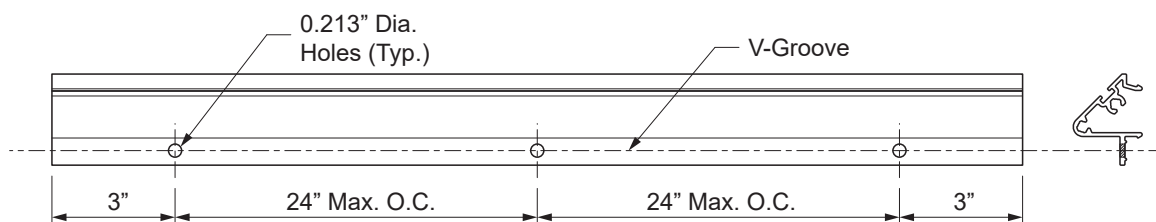

Detail 14

E9-2741 Shown,
Others Similar

FRAME FABRICATION

**STEP 7
FABRICATE HEAD RECEPTOR**

-Cut the head receptor to the frame width plus(+) 5/16” at each jamb.

Note: For additional possibilities such as slab edge cover application, it is recommended to provide additional space between the edge of the head receptor and the jamb substrate.

- For frame openings longer than 24’-0”, allow for a 3/8” splice joint between sill flashing members every twelve to fifteen feet at the center of a D.L.O.
- Mark the front face of the head receptor at the center of each vertical location and the midpoint of the daylight opening between the verticals.
- Drill a 5/16” diameter weep holes in the head receptor at each location marked.
- Drill clear holes for anchor fasteners into the head receptor as indicated on the approved shop drawings and or P.E. calculations.

See **Detail 15**.

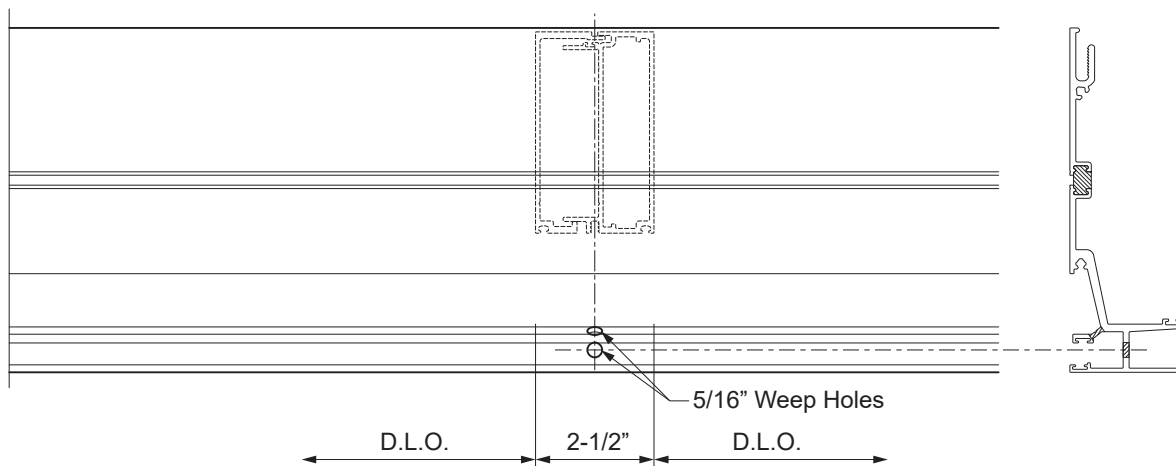

Detail 15

Note: Anchor Hole Locations Shown for Reference Only

FRAME ASSEMBLY

**STEP 8
ASSEMBLE FRAME**

Note: It is recommended to lay out the unit pieces face down on a table or saw horses during assembly, fully supporting the mullions. If using saw horses, a brace tying the two together will be required.

-If strap anchors are used at the head, insert them into the head member prior to assembly (2 per Daylight Opening, unless otherwise noted).

-Apply sealant to the end of the horizontal members to be attached to the first mullion or jamb, at the shaded areas of the head and intermediate horizontals and the entire end of the sill.

See **Detail 16**.

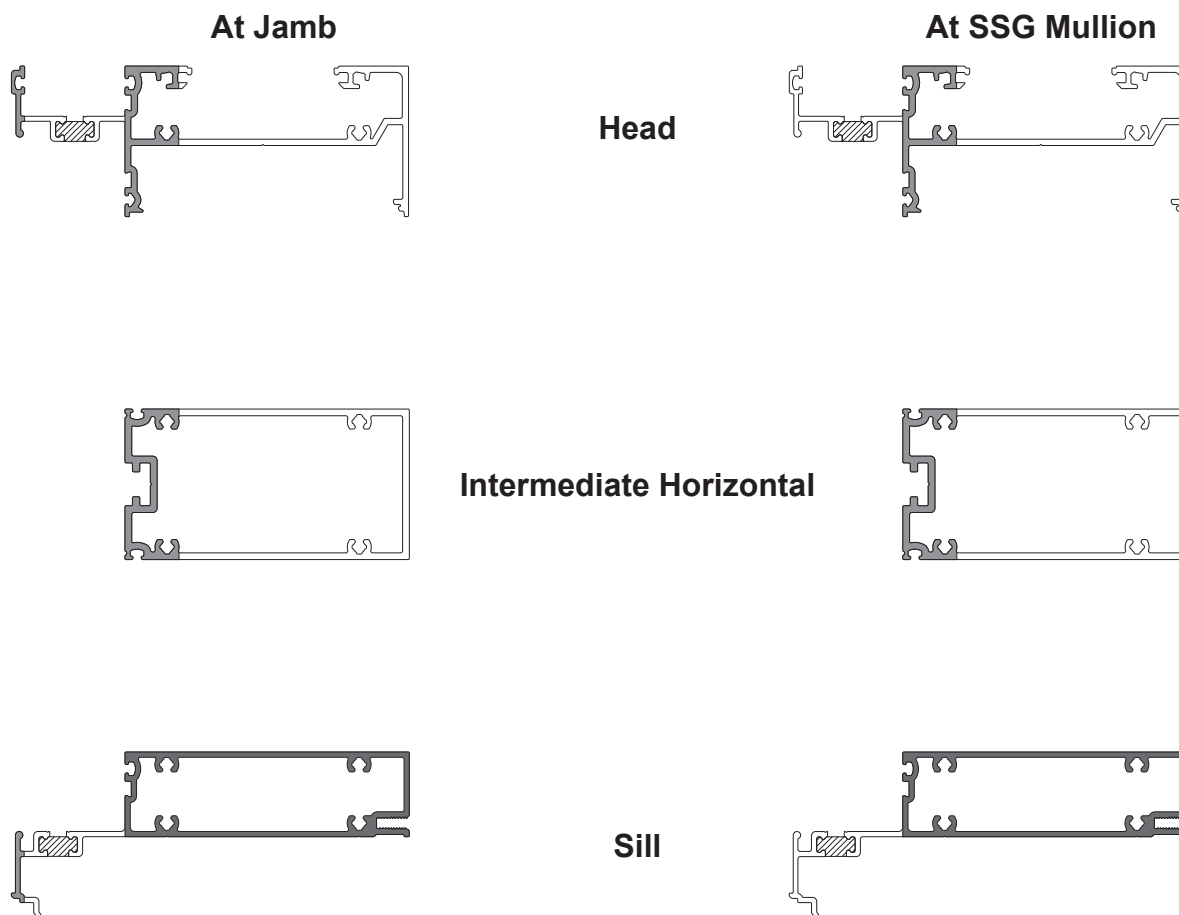

Detail 16

FRAME ASSEMBLY

**STEP 8 (Continued)
ASSEMBLE FRAME**

-Attach the horizontal members to the first mullion or jamb using PC-1220 screws, ensuring the bottom and back of the sill aligns with the bottom and back of the mullion as shown in **Detail 17A**.

See **Detail 17**.

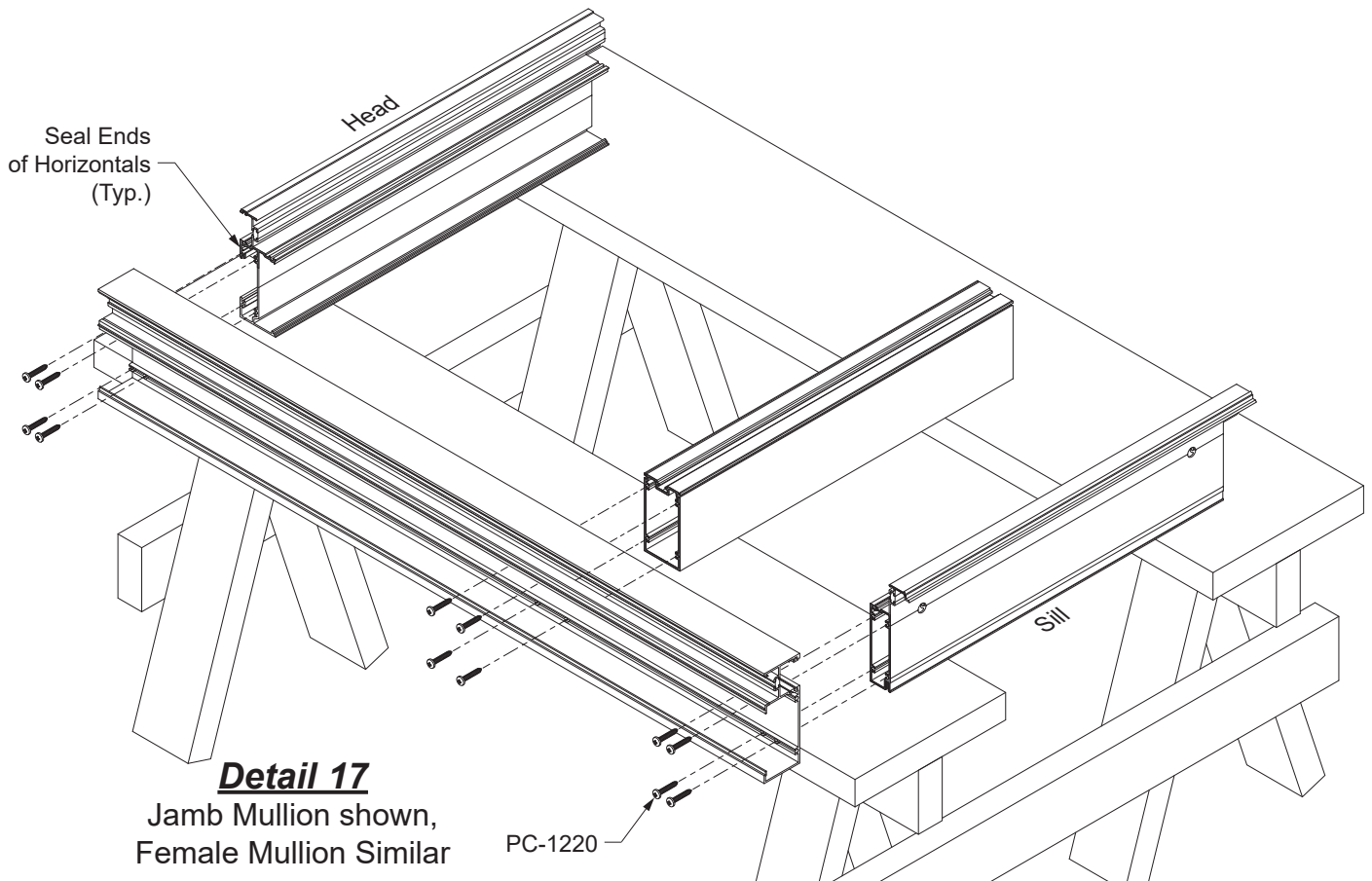

Detail 17
Jamb Mullion shown,
Female Mullion Similar

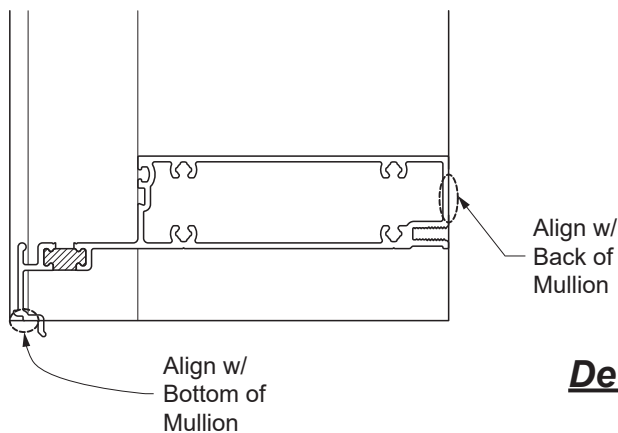

Detail 17A

FRAME ASSEMBLY

STEP 8 (Continued) ASSEMBLE FRAME

- Apply sealant to the end of the head, horizontals, and sill that is to be attached to the second mullion or jamb as previously shown in **Detail 17**, also ensuring proper alignment at the bottom of the mullion.
- Attach the horizontal members to the mullion using PC-1220 screws. See **Detail 18**.

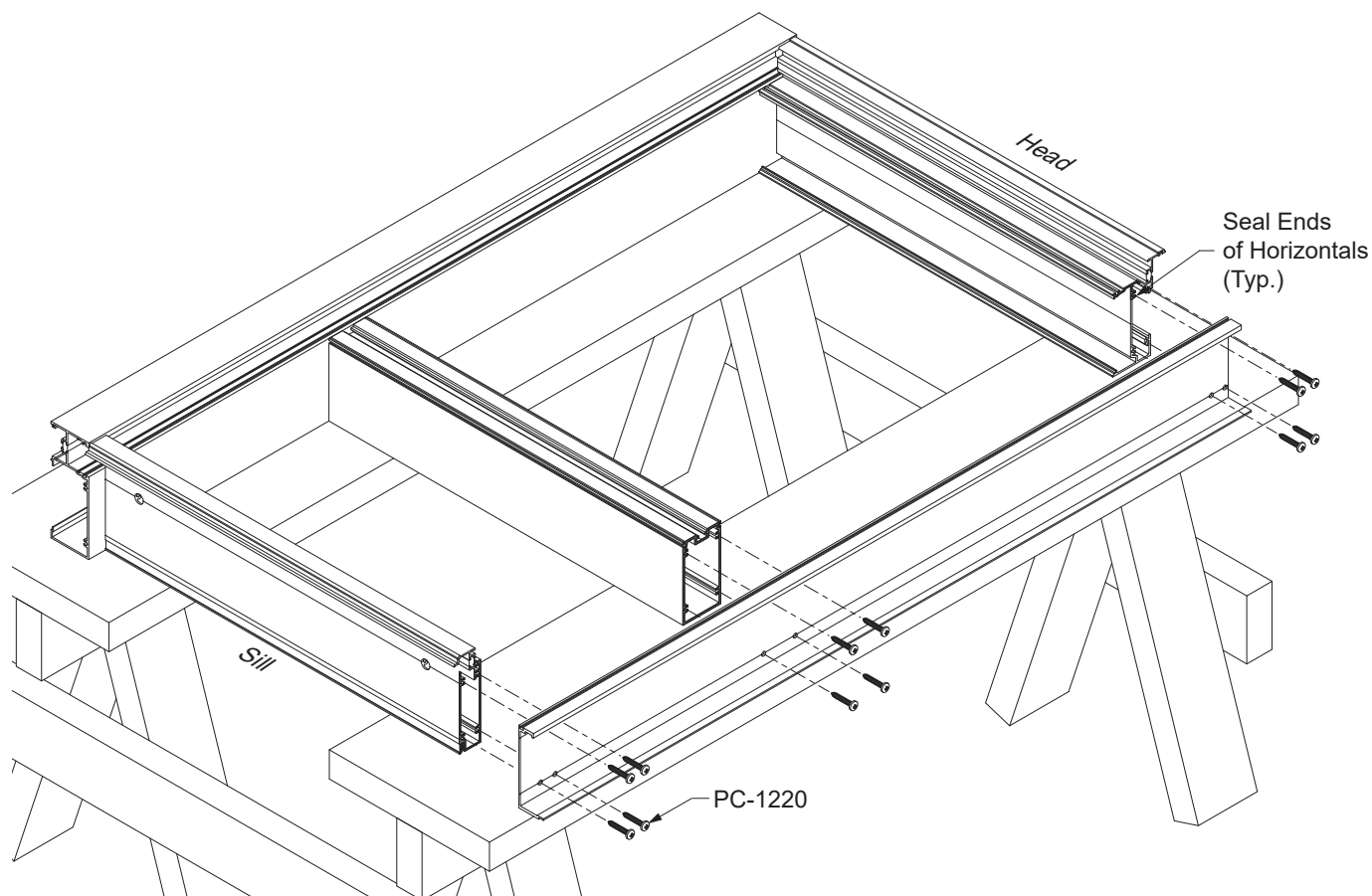

Detail 18

FRAME ASSEMBLY

**STEP 8 (Continued)
ASSEMBLE FRAME -- CORNER MULLION**

- Apply sealant to the interior snap interface of the interior corner cover, 6" up from the bottom of the mullion. Snap the cover pieces onto the corner mullion half. Fasten with PM-1006-SS fasteners at the holes previously drilled in fabrication.
- The exterior corner covers will require E2-0051 bulb gaskets cut to the length of the mullion. Apply dabs of sealant to the bottom of the bulb gasket to adhere it to the cover so that it will not slide out during unit installation. Do not overseal. Insert the gasket into the reglet at the cover.
- The 90° corner cover (E9-2740) will also require an E2-0110 spacer tape adhered to the cover for one side of the corner. This will keep the cover joint true. (The other corner half for the adjoining unit will not need this spacer tape.)

See **Details 19** for YWW 50 TU and **Detail 20** for YWW 60 TU.

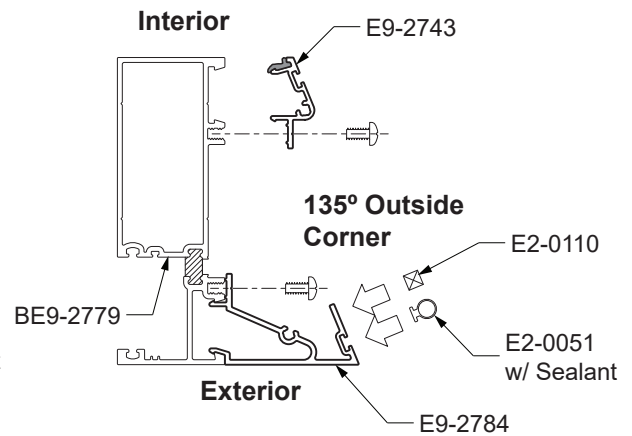
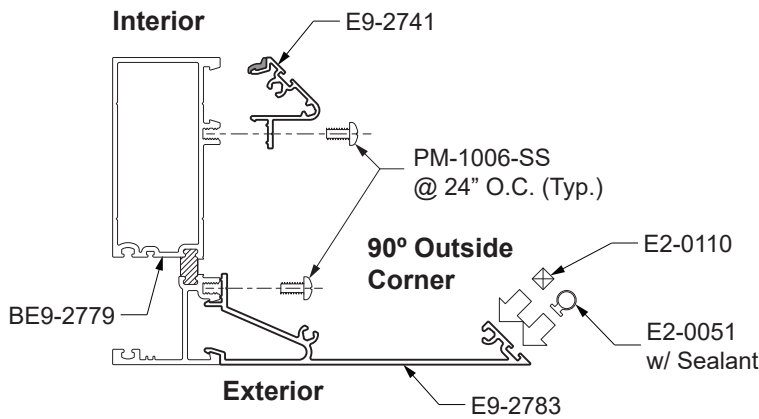

Detail 19
YWW 50 TU

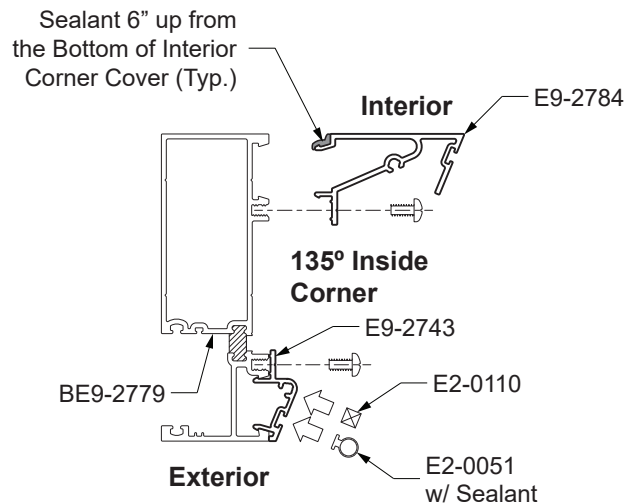
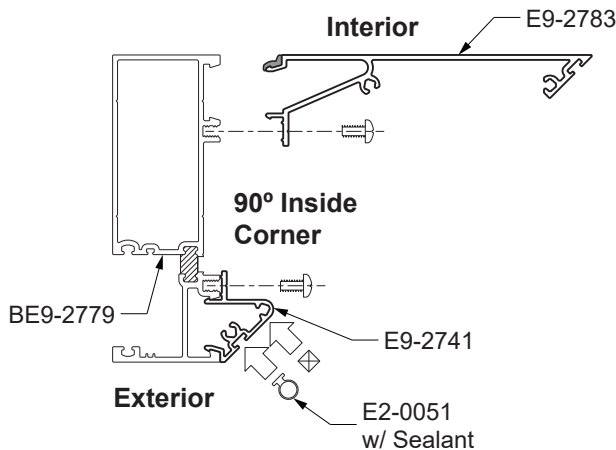

FRAME ASSEMBLY

STEP 8 (Continued)
ASSEMBLE FRAME -- CORNER MULLION

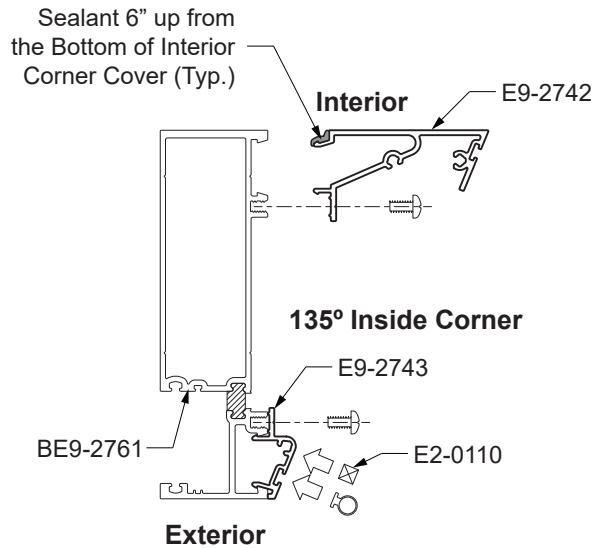
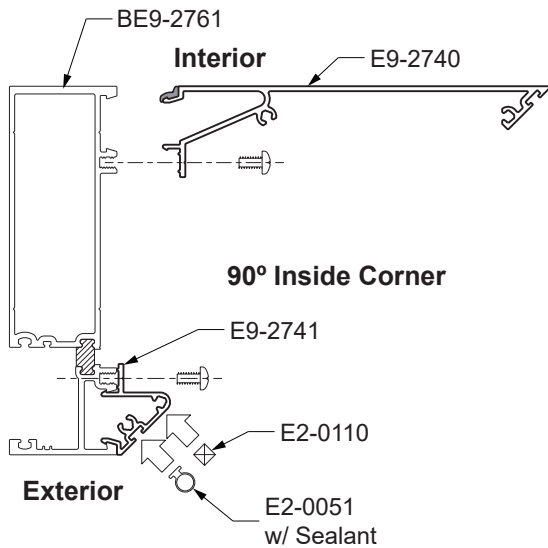
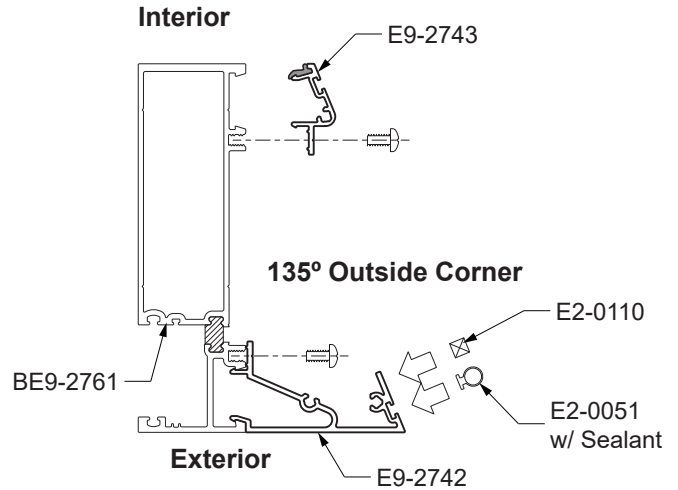
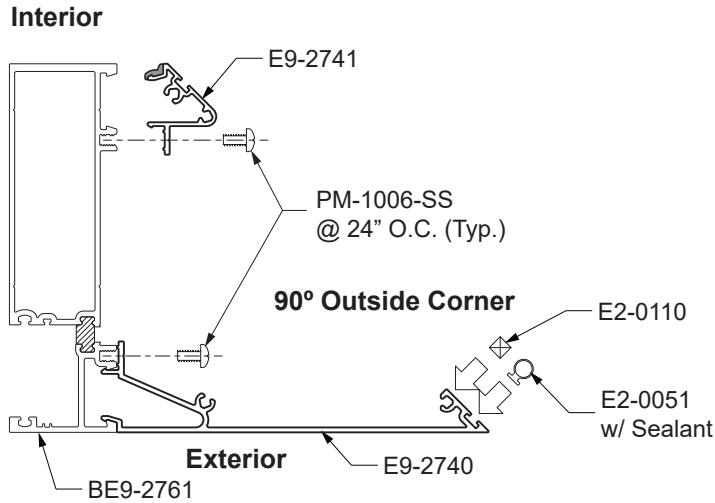

Detail 20
YWW 60 TU

FRAME ASSEMBLY**STEP 9 (Optional)
INSTALL STEEL REINFORCING**

- Install steel reinforcing into the mullions and jambs as required by the P.E. calculations and or approved shop drawings.
- Take care that the fasteners do not interfere with the horizontals nor would be visible when the unit is installed.

See **Detail 21**.

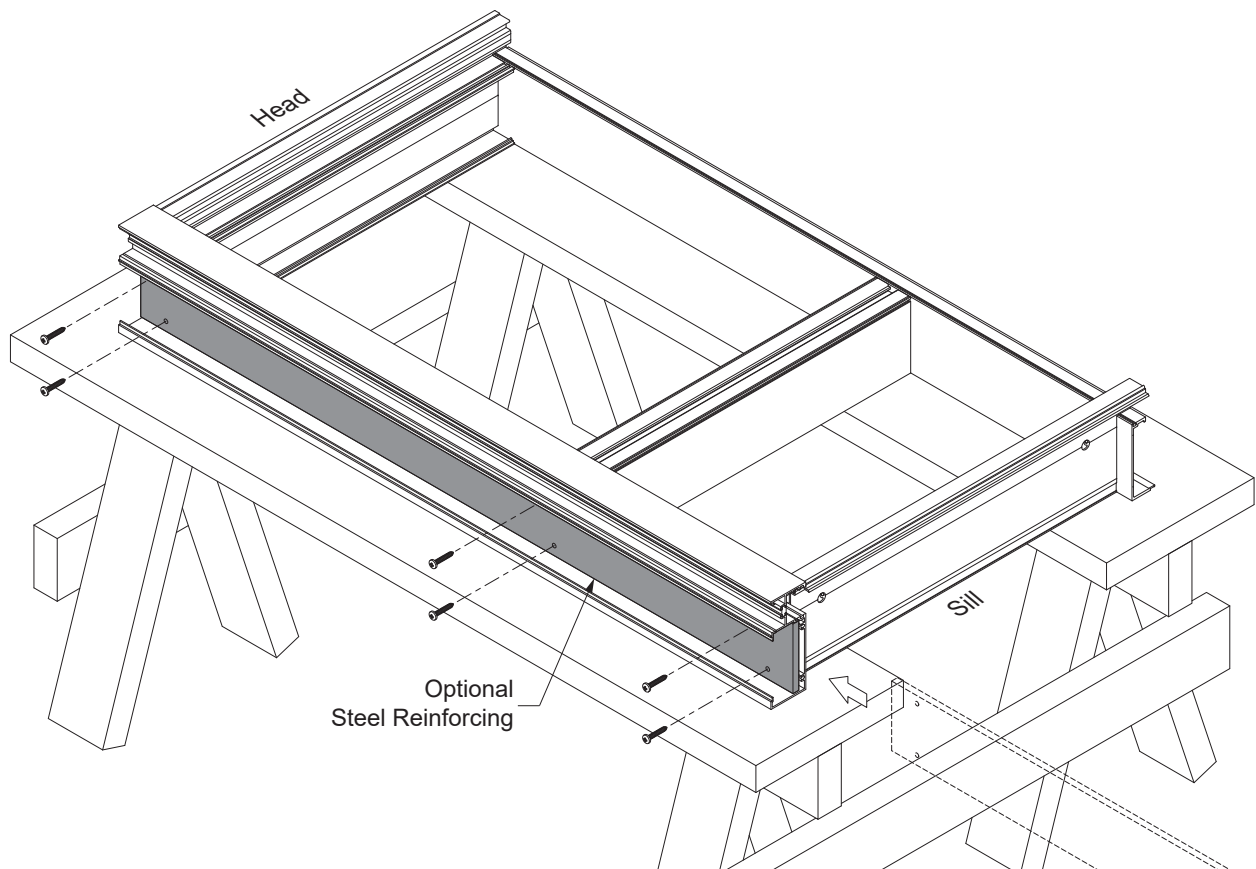

Detail 21

FRAME ASSEMBLY

STEP 10 INSTALL PERIMETER FILLERS

Install perimeter fillers into the jamb mullions and the head member.

-For the head, cut the E3-3664 pocket filler to horizontal daylight opening minus(-) 1/32" and snap it into the perimeter glazing pocket, centered on the D.L.O.

-If jamb strap anchors are used, install them into the jambs prior to installing perimeter fillers. See **Detail 22**.

-At the jamb, cut the E3-3664 pocket filler to length of vertical and install it into the jamb.
-Cut the flat filler (E3-0032 for YWW 50 TU and E3-0023 for YWW 60 TU) to the length of the jamb, except where strap anchors would interfere. Snap the filler into place.

See **Detail 23**.

Note: E3-0023 is not required for heavy duty jamb mullion.

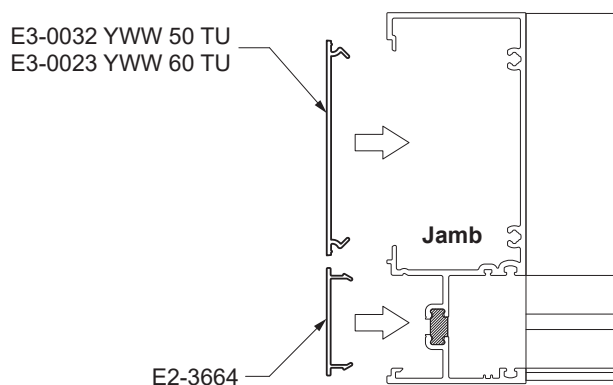

Detail 22

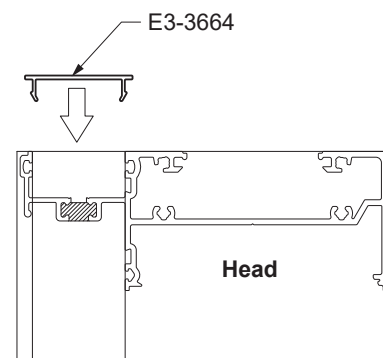

Detail 23

FRAME ASSEMBLY

**STEP 11 (Not Necessary with Head Receptor)
INSTALL FOAM PLUGS AT HEAD**

- Cut E2-0259 foam backer tape (maximum 1-1/4" long) to be installed at the head only. These will act as end caps for perimeter backer rods and sealant.
- Peel the adhesive tape from the foam and adhere it to the mullion as shown in **Detail 24**. The foam can be easily compressed around physical obstacles in the assembled verticals.
- In the case where steel reinforcing is present at the head, the foam plugs may be adhered to the steel.
- Fill the cavities at the front of any captured jambs with sealant.

Note: For best adhesion, make sure the contact surfaces of the verticals and or steel members are clean and dry.

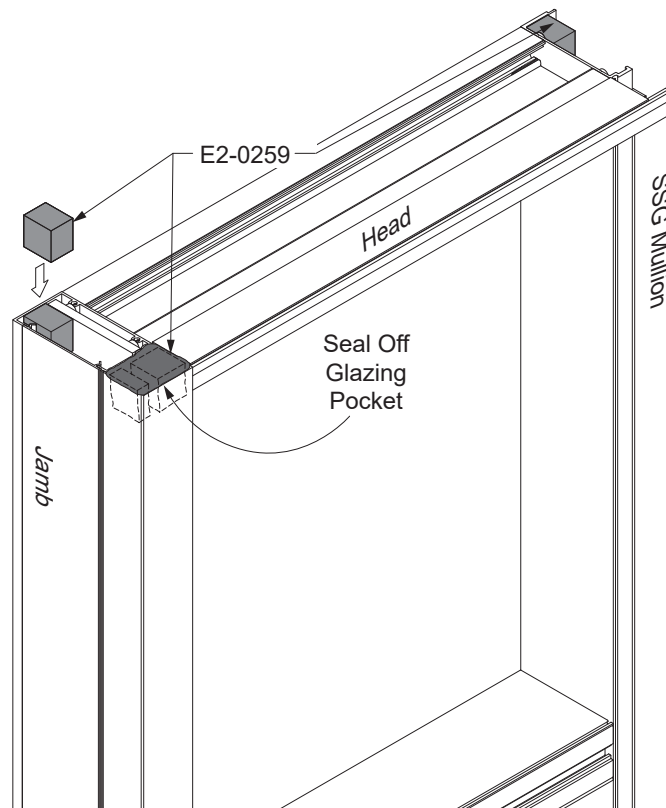

Detail 24
Shown Upright
for Clarity

FRAME ASSEMBLY

STEP 12 INSTALL WEATHER SEAL

Weather seal gaskets (E2-7010) are installed in the female mullion only.

-Cut the weather seal gasket to length of the vertical plus(+) 3", and install into the interior reglet of the male mullion in the proper orientation as shown in **Detail 25**.

-Apply dabs of sealant to the bottom of the weather seal gasket to adhere it to the mullion so that it will not slide out during unit installation. Do not overseal. Too much silicone will deter mullion engagement.

-Trim the weather seal gasket after shrinkage.

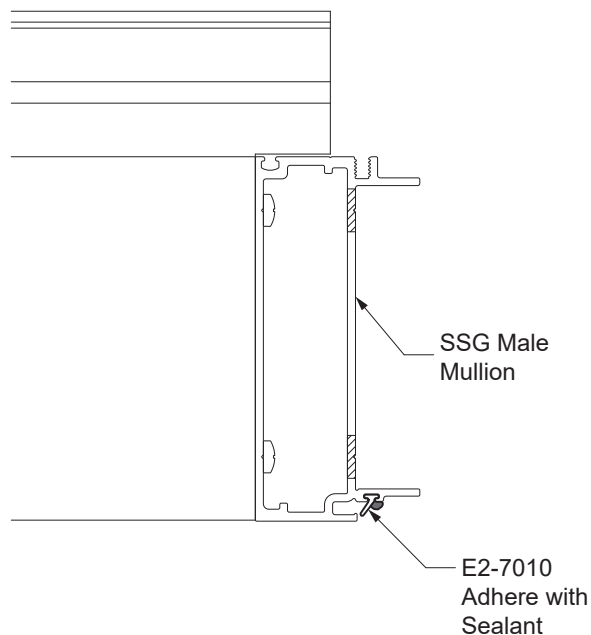

Detail 25

FRAME ASSEMBLY

**STEP 13
INSTALL INTERIOR GLAZING GASKETS**

-Using a small brush, clean out any dirt that may have accumulated in the gasket reglets.

Vertical glazing gaskets must be installed first:

- Cut vertical gaskets to the Daylight Opening plus(+) 3/4" plus(+) an additional 1/4" for each foot of length. For E2-0541 only, notch the ends of the vertical gasket as shown in **Detail 26**.
- Insert the gasket into the reglets at each end first; then insert the gasket at the midpoint of the opening.
- Push the gasket into the reglet starting at the midpoint and work towards each end.

See **Detail 27**.

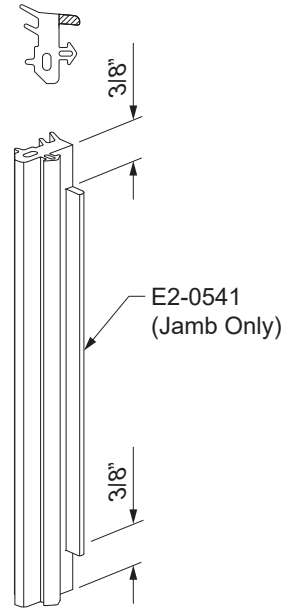

Detail 26

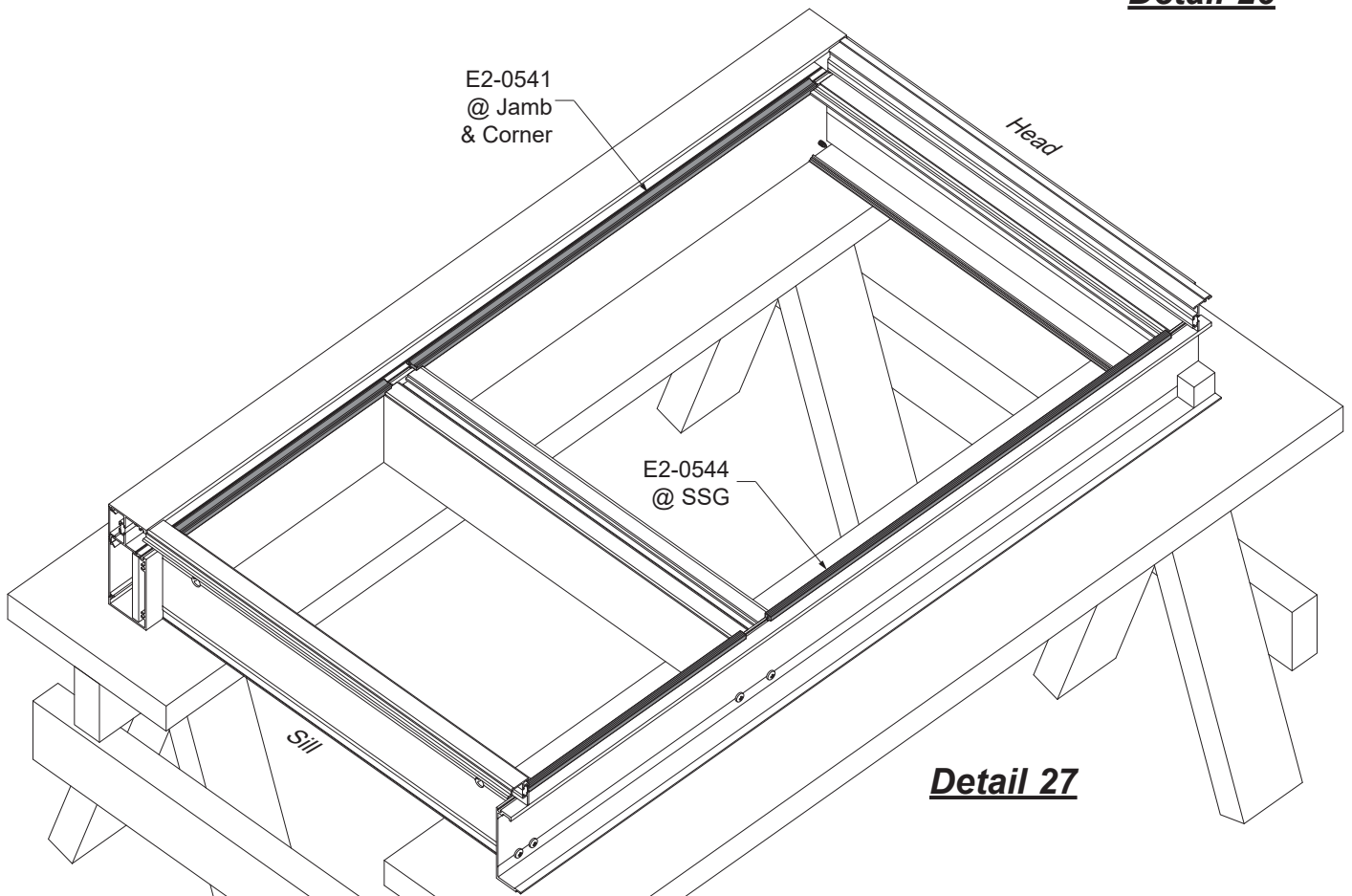

Detail 27

FRAME ASSEMBLY

STEP 13 (Continued)
INSTALL INTERIOR GLAZING GASKETS

Install horizontal glazing gaskets next:

- Cut horizontal glazing gaskets to Daylight Opening plus(+) 1/4" for each foot of length.
- Apply sealant to each end of the horizontal glazing gasket prior to inserting into the reglet.
- Insert the gasket into the reglet at each end first; then insert the gasket at the midpoint of the opening.
- Push the gasket into the reglet starting at each end and work towards the midpoint.
- Tool the excess sealant at the gasket corners to ensure a watertight seal.

See **Detail 28**.

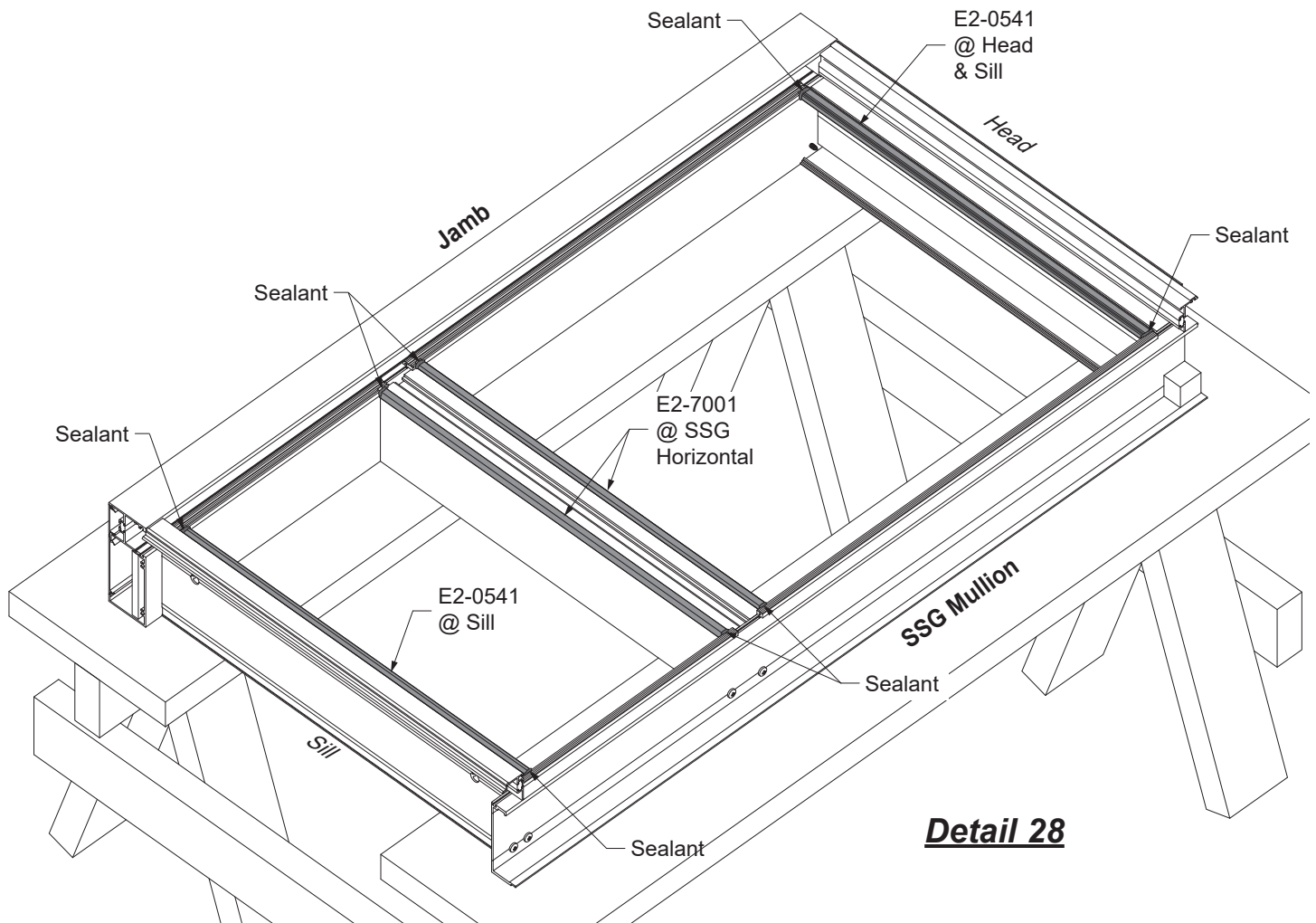

Detail 28

GLAZING

**STEP 14
INSTALL SETTING / SIDE BLOCKS**

-Apply setting blocks into the glazing pockets for every sill and intermediate horizontal as shown in **Detail 29** at quarter points at every daylight opening. Adhere the setting blocks with sealant. For jamb mullions, add E2-0628 setting blocks as shown (adhere with sealant).

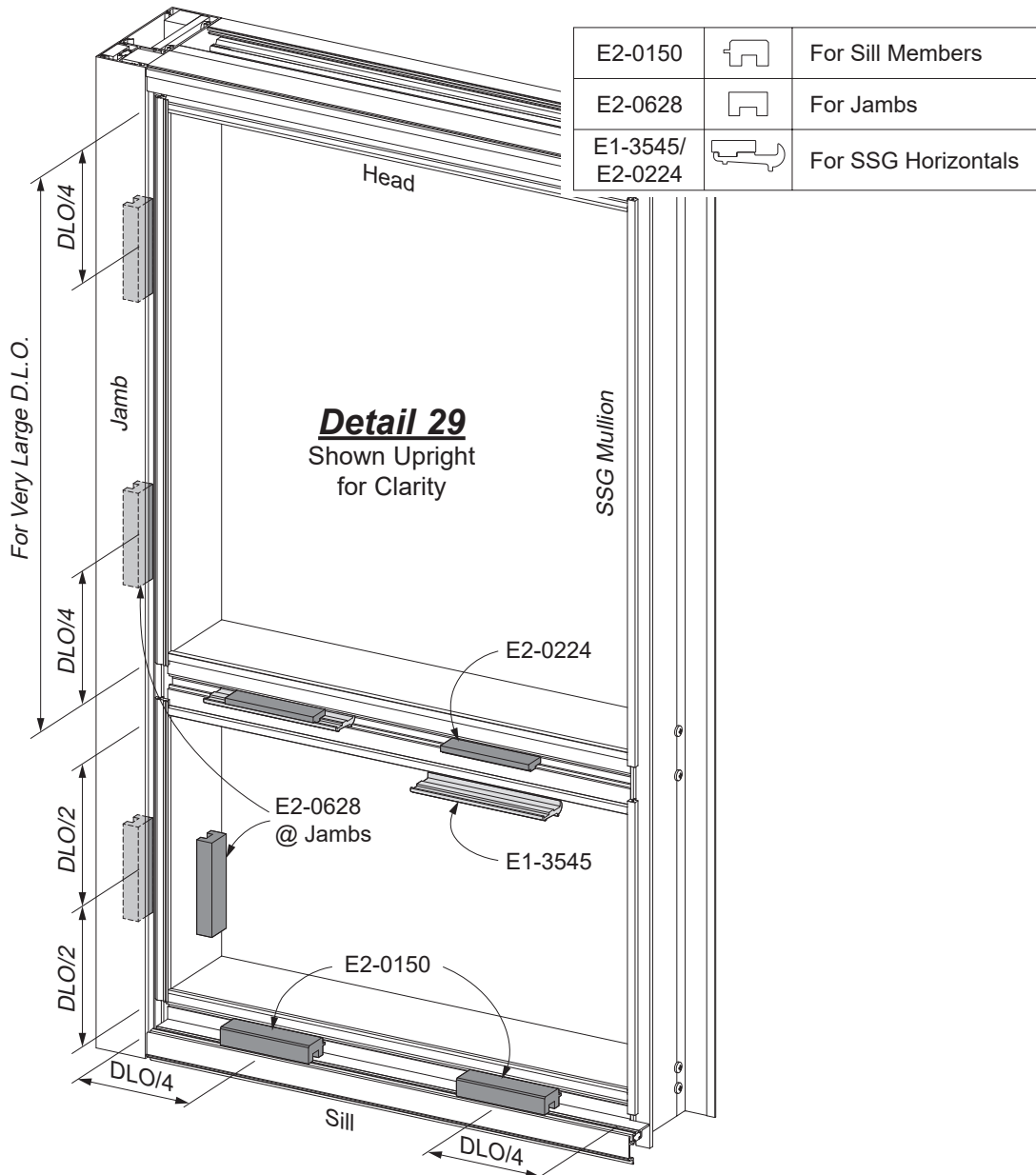

Packing/Shipping Notes for Jamb Units:
If packing units horizontally, ship with jamb side down.

GLAZING

**STEP 15
INSTALL GLASS**

Determine the glass size based upon the vertical and horizontal conditions illustrated in **Detail 29**.

Ensure the unit is square before glazing

-Install the glass lites into the daylight openings. Position the glass lites ensuring the proper glass bites all around and tight against the setting blocks. Align the exterior edge of the glass with the edge of the female mullion half and the V-groove on the male mullion half.

See **Details 30, 31, & 32**.

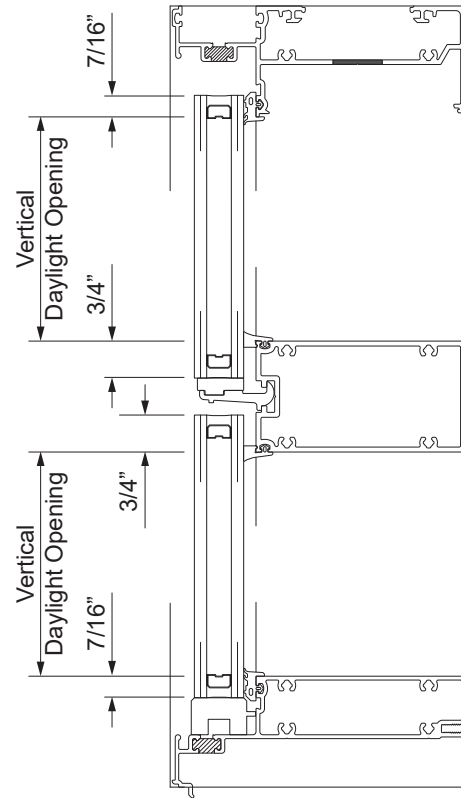

Detail 30

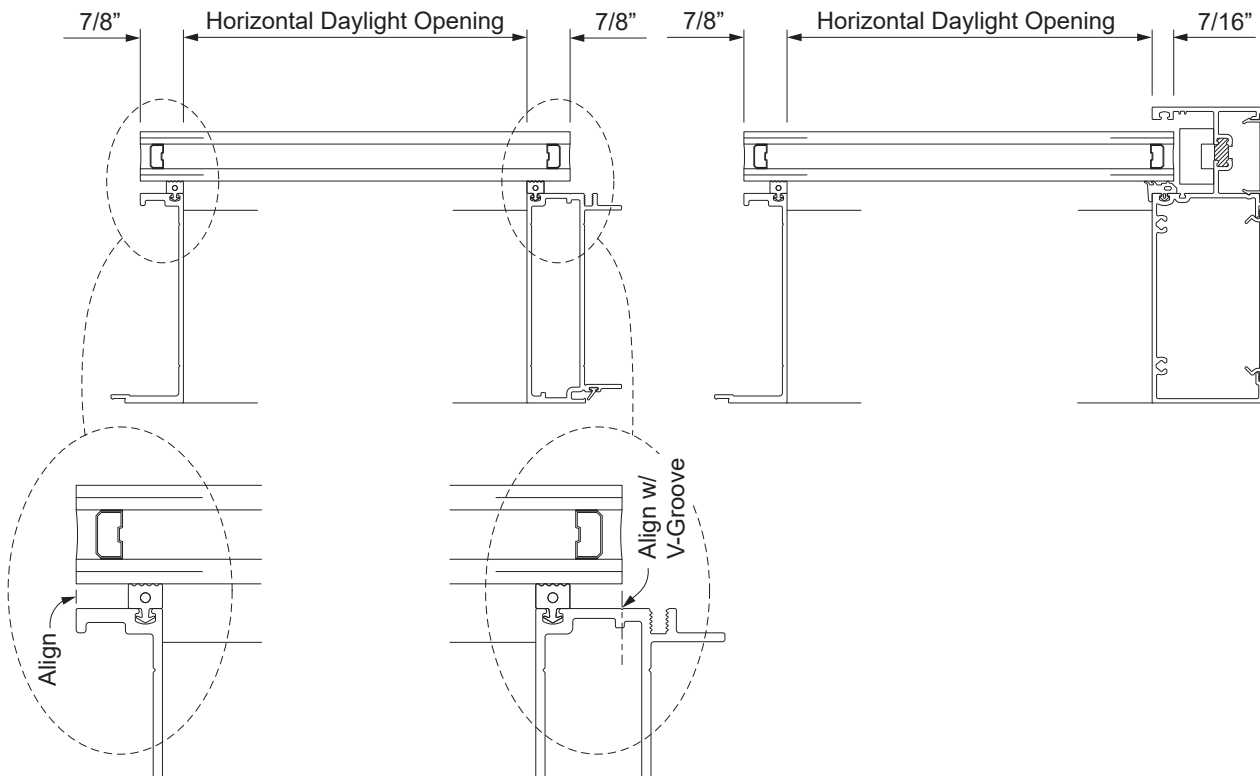

GLAZING

**STEP 15 (Continued)
INSTALL GLASS**

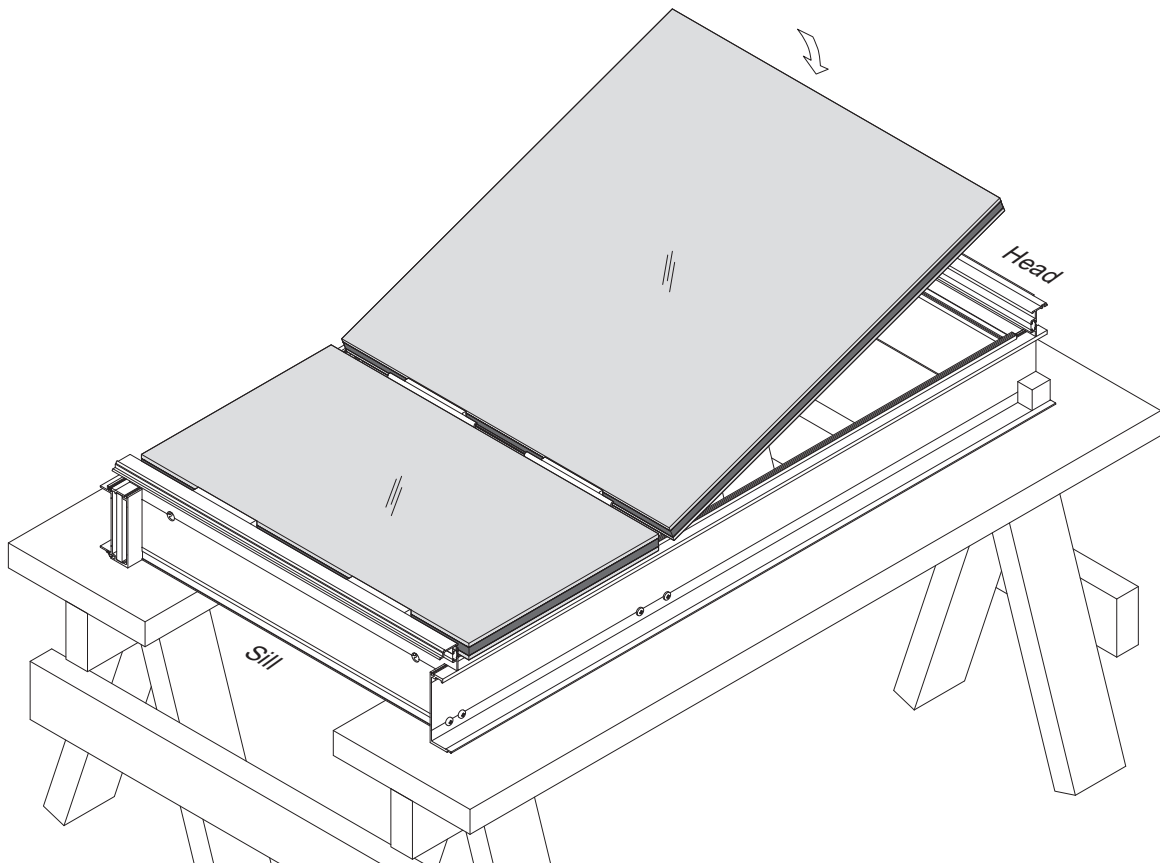

Detail 31
Intermediate Unit

GLAZING

STEP 15 (Continued)
INSTALL GLASS

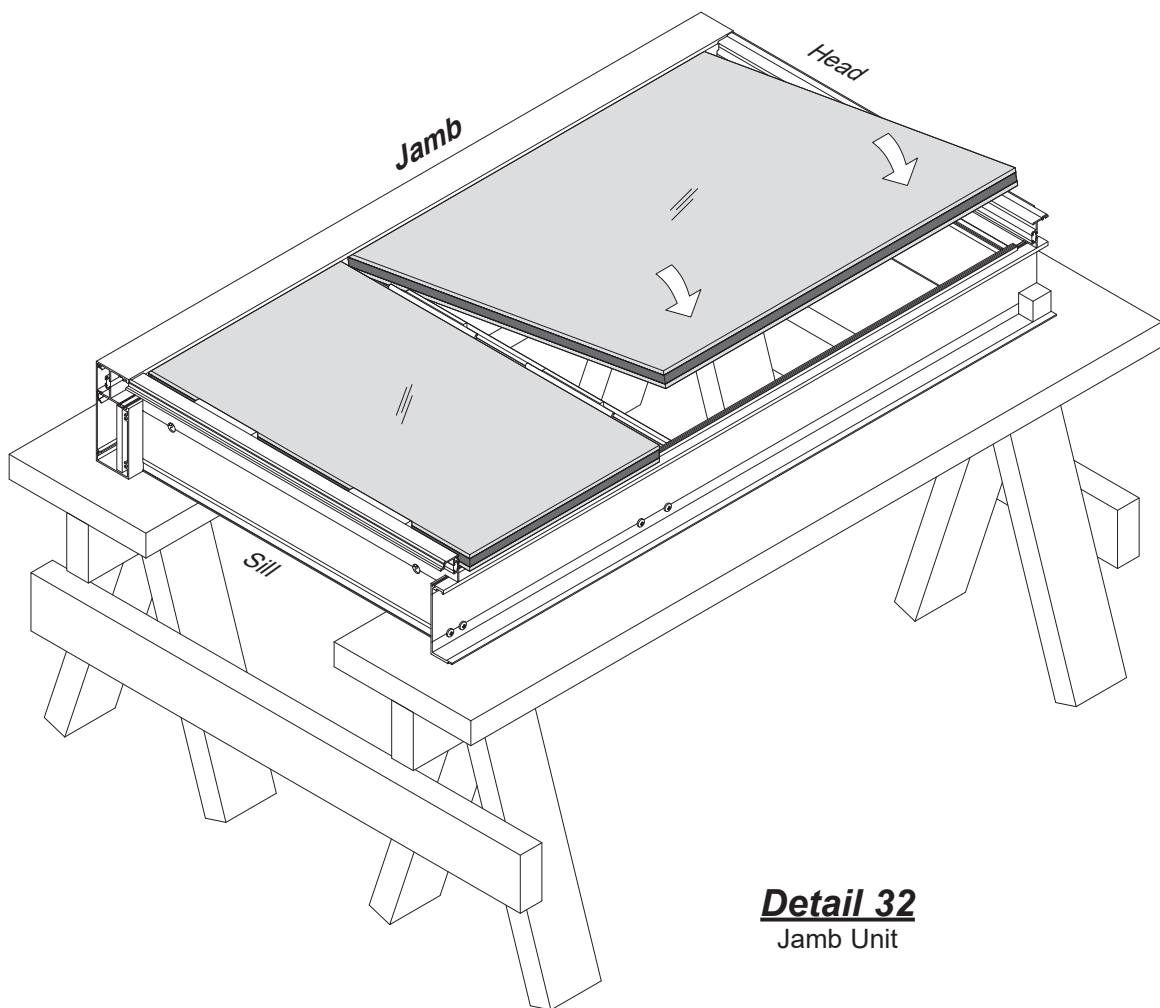

Detail 32
Jamb Unit

GLAZING

**STEP 16
SEAL GLASS TO FRAME**

-Apply structural silicone sealant to the gap between the glass and the frame, first at the intermediate SSG horizontals as shown in **Detail 33**.

Note: the setting blocks/chairs may need to be moved temporarily to properly seal the glass to the horizontals, and then relocated back to their intended positions once finished.

-Apply the sealant to the remaining perimeter of the glass as shown in See **Detail 34**.

Note: Do not move the units until the sealant is fully cured.

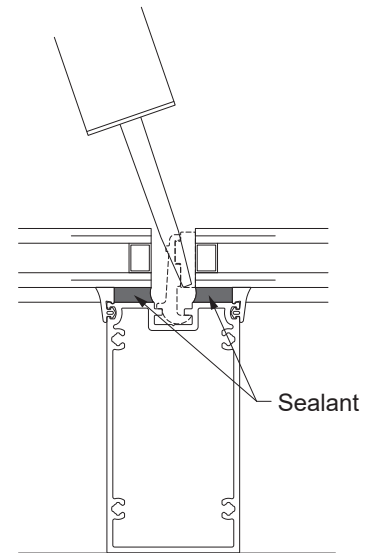

Detail 33

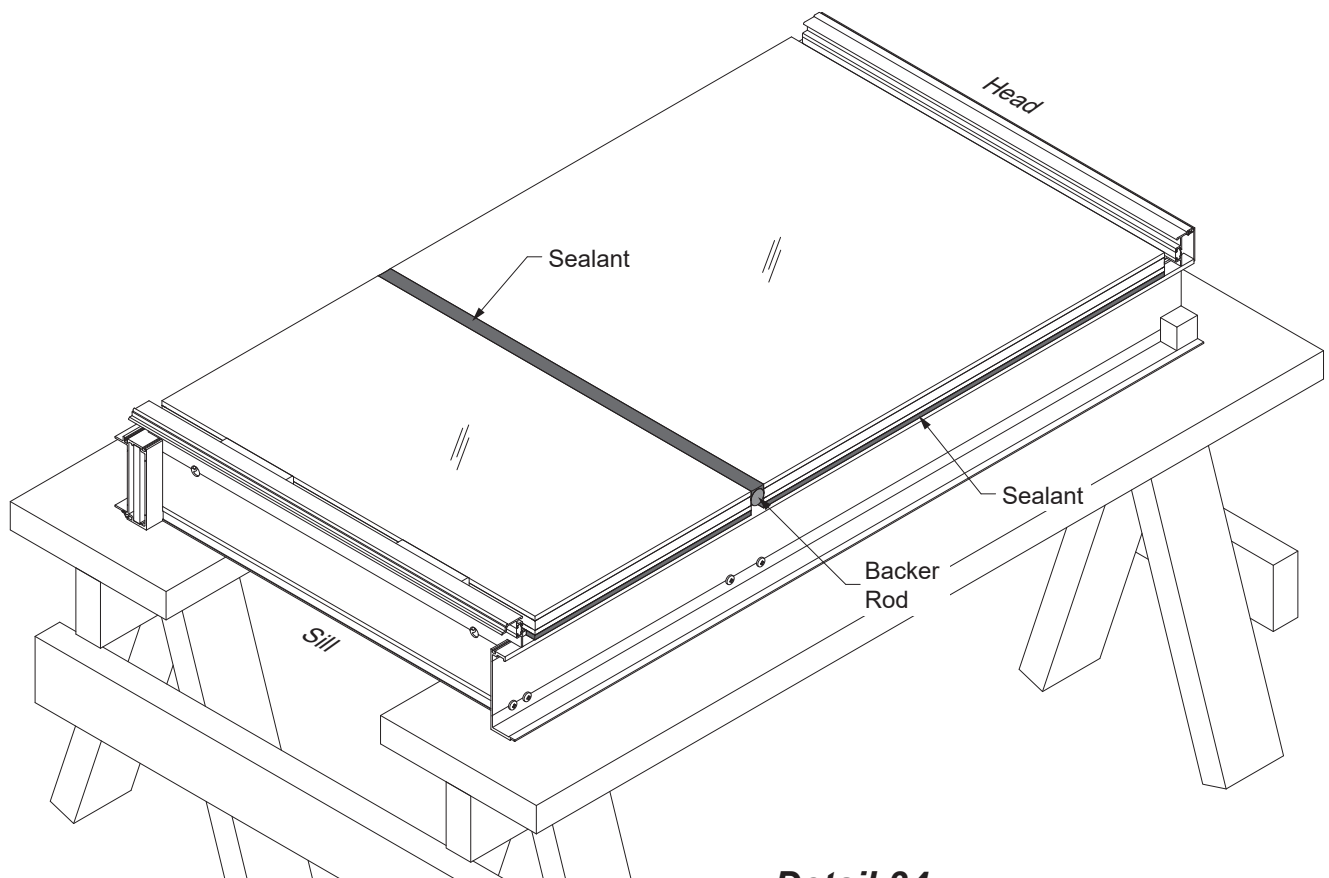

Detail 34

GLAZING

**STEP 17
INSTALL GLASS STOPS (FOR JAMB UNITS)**

- Apply sealant to the top corners of the jambs where the E2-1715 glass stops will be set against.
- Set the E9-1715 glass stops in place at the head and sill. Insert a 2" long section of E2-0542 gasket to temporarily hold the glass in place.
- Tool sealant at intersection of the glass stop to the vertical mullion.

See **Detail 35**.

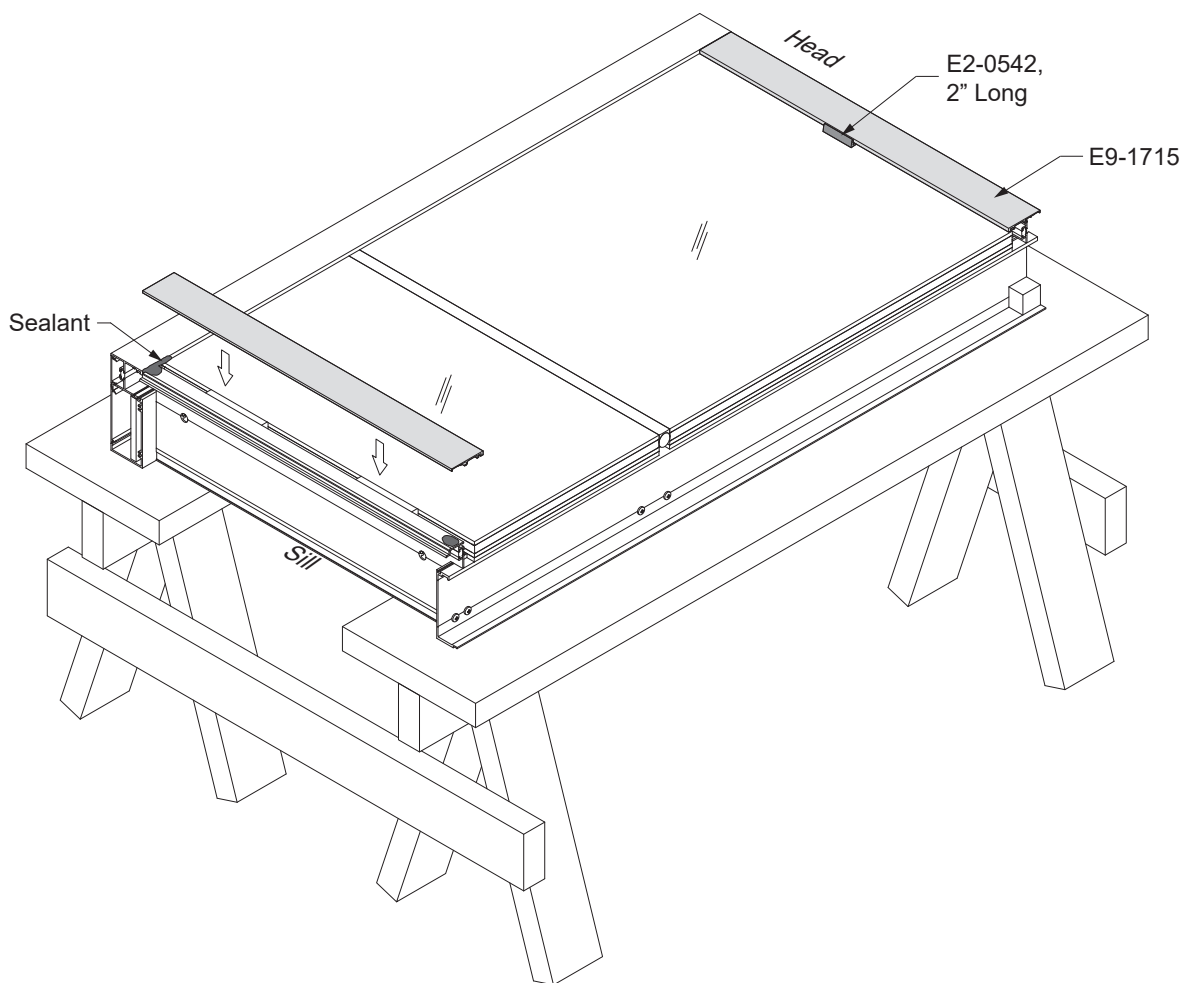

Detail 35

GLAZING**STEP 17 (Continued)****INSTALL GLASS STOPS (FOR INTERMEDIATE UNITS)**

-Installation of the exterior glass stops is similar to that for the jamb unit except the glass stop is centered on the horizontal daylight opening and sealant is not applied to the corners.

See **Detail 36**.

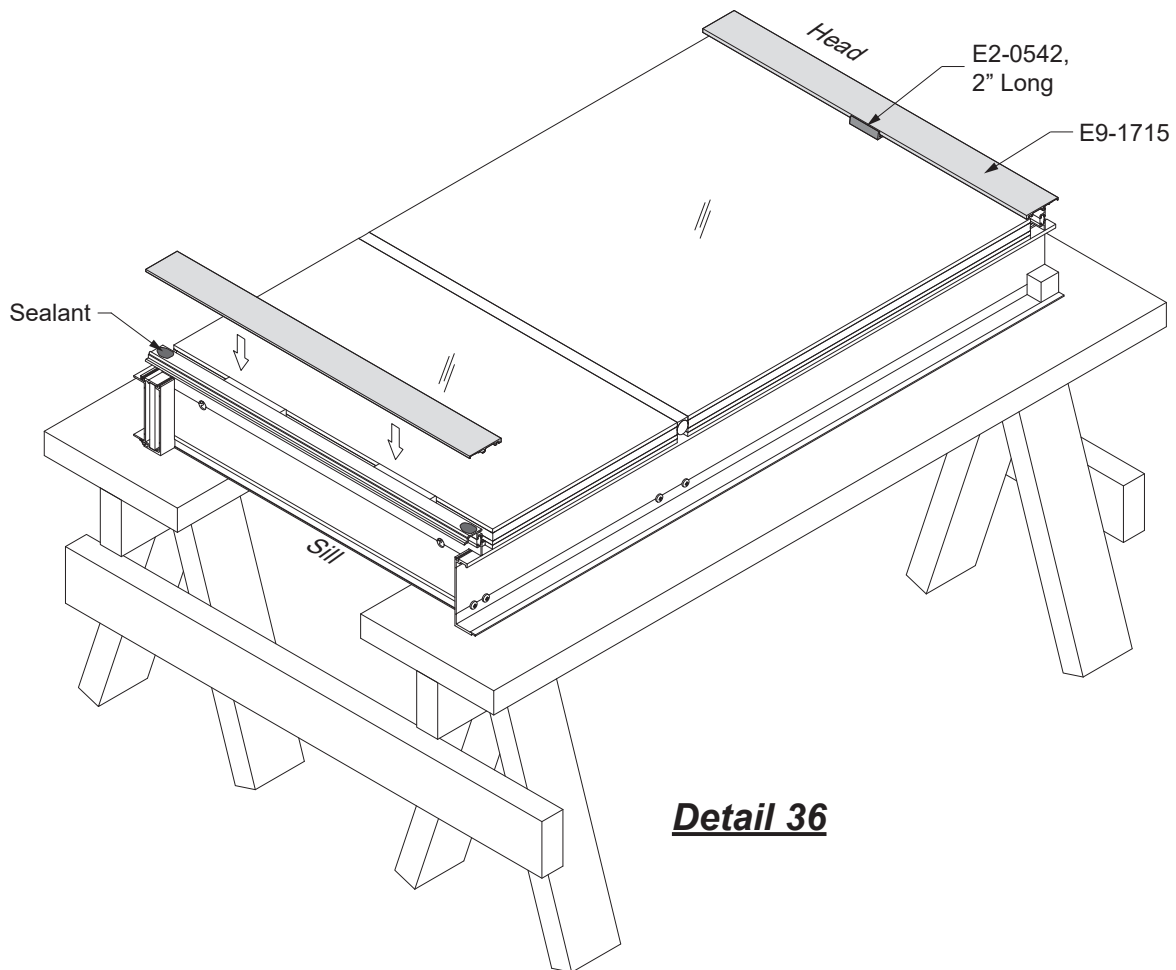

Detail 36

GLAZING

STEP 18
INSTALL SSG RAINSCREEN GASKET

-Cut the E2-0540 SSG rainscreen gasket to frame height minus (-) 4-1/2". Apply sealant to both ends where the gasket engages the mullion as shown below in **Detail 37**. Insert the gasket into the mullion, centered vertically on the framing unit. A screen roller tool and lubricant is recommended.

Note: Ensure that the distance between the end of frame and the end of the rainscreen gasket at each end is 2-1/4". Distances shorter than that will create difficulty for installing the joint plugs at the head and sill later on **Page 40**.

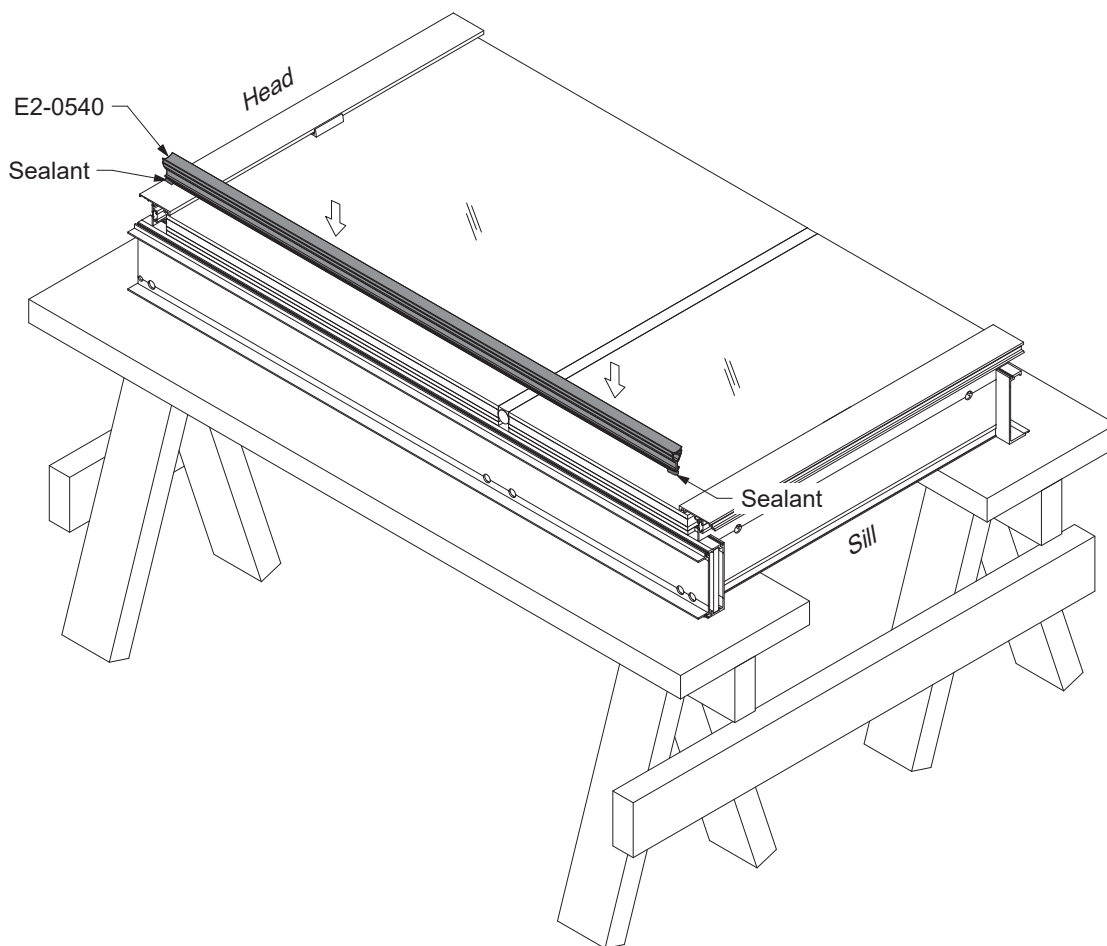

Detail 37

GLAZING

**STEP 19
INSTALL VERTICAL WEDGE GASKET (FOR JAMB UNIT)**

- Cut the E2-0542 wedge gasket to frame height minus (-) 3-3/4".
- Notch each end of the gasket by 3/8" as shown in **Detail 38**.
- Insert the gasket into the exterior jamb glazing pocket, starting at the ends first and working towards the midpoint as shown in **Detail 39**.



Detail 38

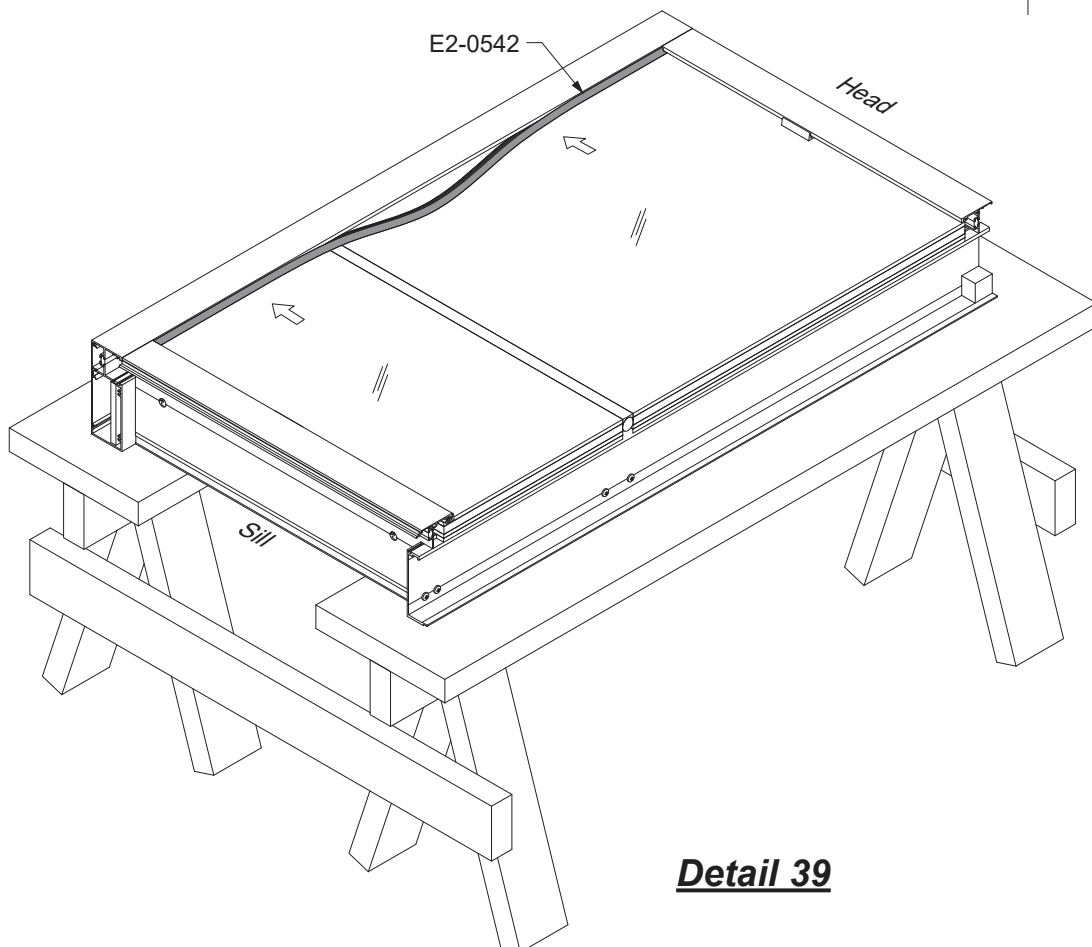

Detail 39

GLAZING

STEP 19 (Continued) INSTALL HORIZONTAL WEDGE GASKET

- Cut the E2-0542 wedge gasket to the length of the glass stops.
- For jamb units apply sealant to the end of the wedge gasket where it meets the vertical gasket.
- Insert the wedge gasket into the exterior glazing pocket, centered on intermediate units, and tight against the jamb gasket at jamb units.

See **Detail 40**.

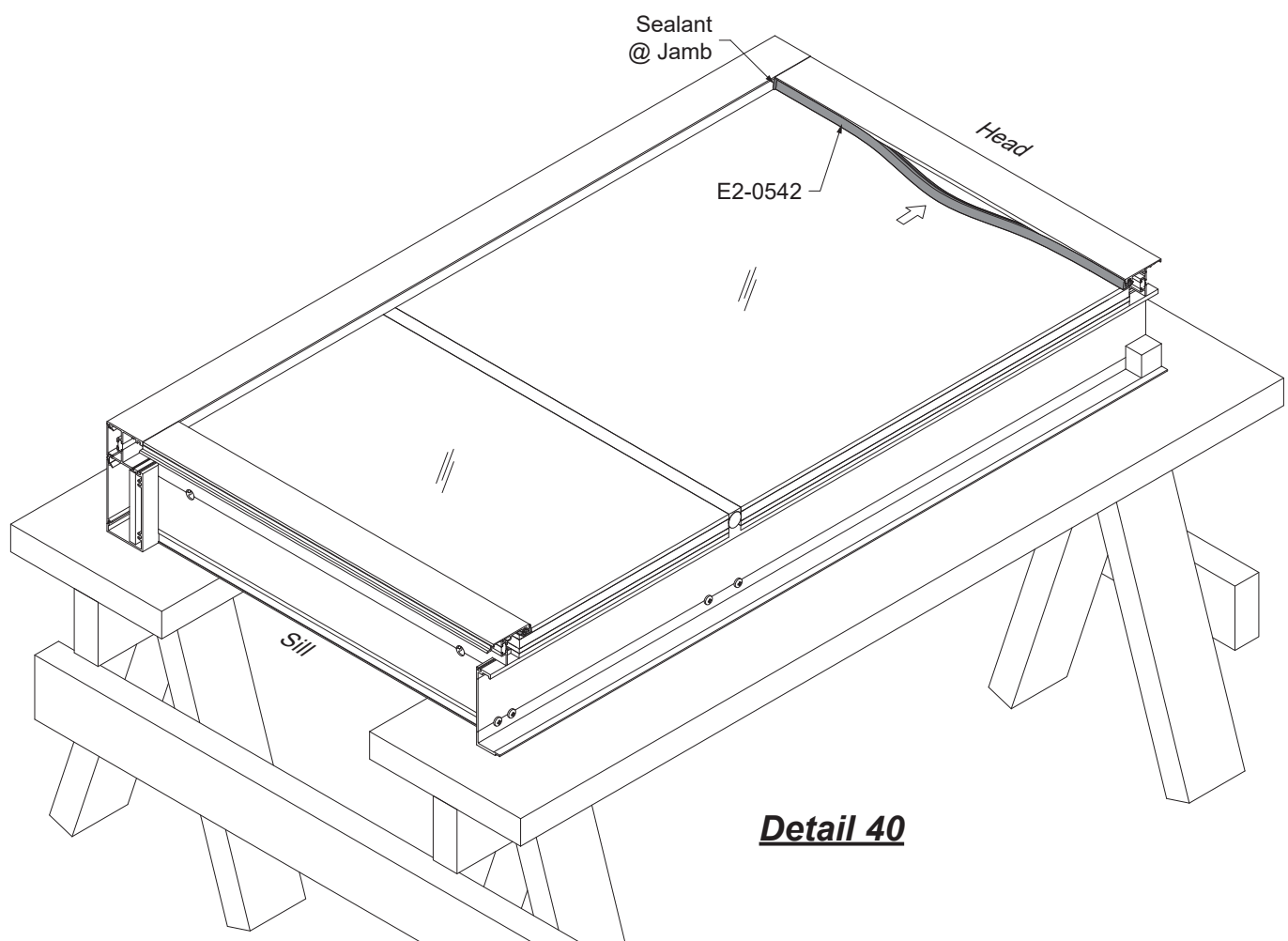

GLAZING**STEP 20
INSTALL JOINT PLUGS**

- Fill the head and sill glazing pockets at the SSG mullion with sealant, giving the E2-9802 joint plugs a surface to adhere to.
- Adhere the joint plugs to the top and bottom of the unit at the SSG mullion, flush with the exterior glass stop. Tape the joint plugs in place until the sealant is cured.

See **Detail 41**.

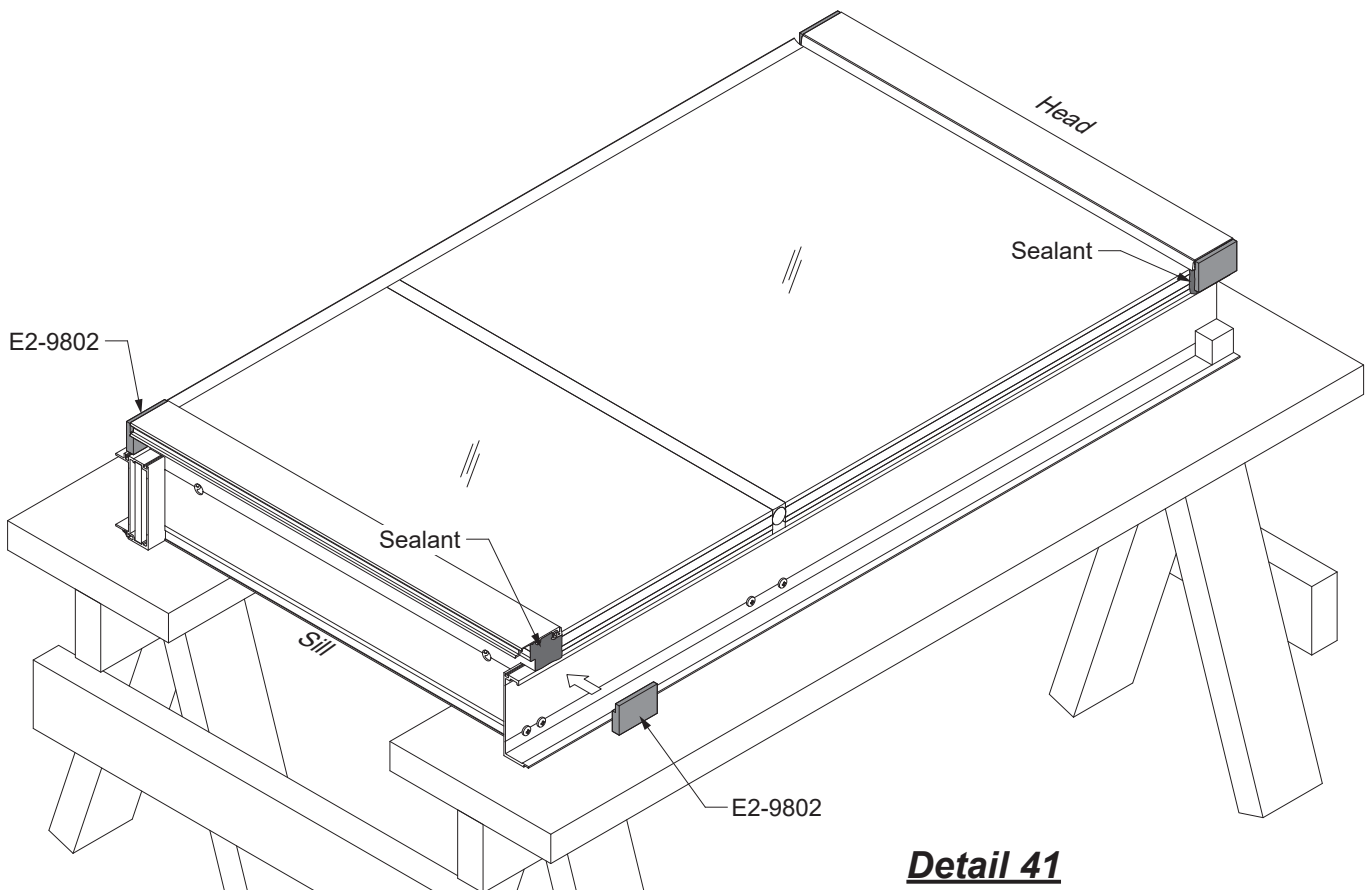

FRAME INSTALLATION

STEP 21
INSTALL SILL FLASHING END DAMS

-Bend the end dam tab left or right 90 degrees in order to “hand” the end dam for the left or right end of the flashing.

See **Detail 42**.

- Clean all joint surfaces using cleaner approved by sealant manufacturer.
- Apply sealant to the end of the sill flashing as shown in **Detail 43**.
- Slide the tab into the top portion of the sill flashing.
- Tap the tab into place with a small tool until the end dam is snug against the end of the flashing.
- Fasten the end dam to the sill flashing with two UA-1212 screws, starting at the back, followed by the front as shown in **Detail 43**.
- Tool sealant along the joint between the end dam and the sill flashing as shown in **Detail 44**.

E1-2851 for YWW 50 TU
E1-2852 for YWW 60 TU

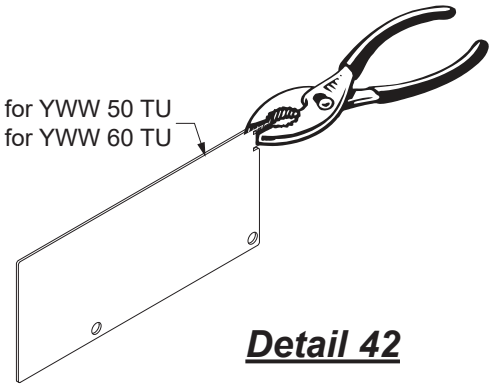

Detail 42

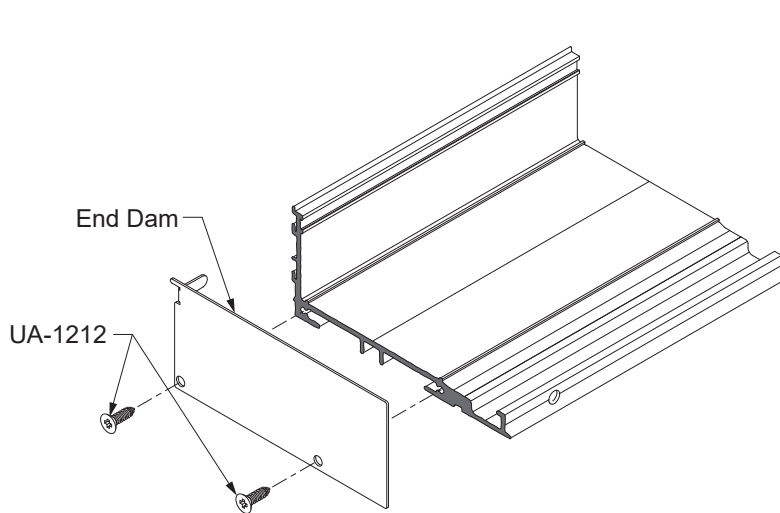
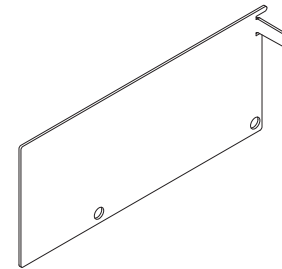

Detail 43

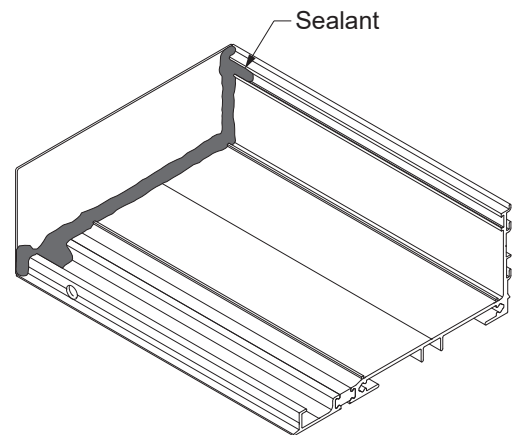

Detail 44

FRAME INSTALLATION

**STEP 21A
INSTALL SILL FLASHING END DAMS FOR SLAB
EDGE COVER**

- Sill flashings with slab edge covers will require an aluminum plate adaptor E9-8222 to be attached prior to field installation.
- Insert (2) E2-0065 weathering gaskets cut to the length of the reglets on the adaptor.
- Slide the slab edge adaptor onto the sill flashing.

See **Detail 45**.

- Installation of the E1-1198 end dam is the same as illustrated in the previous page, except that the end of the installed slab edge adaptor will also require sealant.
- Fasten an E1-1196 end cap onto the slab edge assembly using an additional UA-1212 screw.

See **Detail 46**.

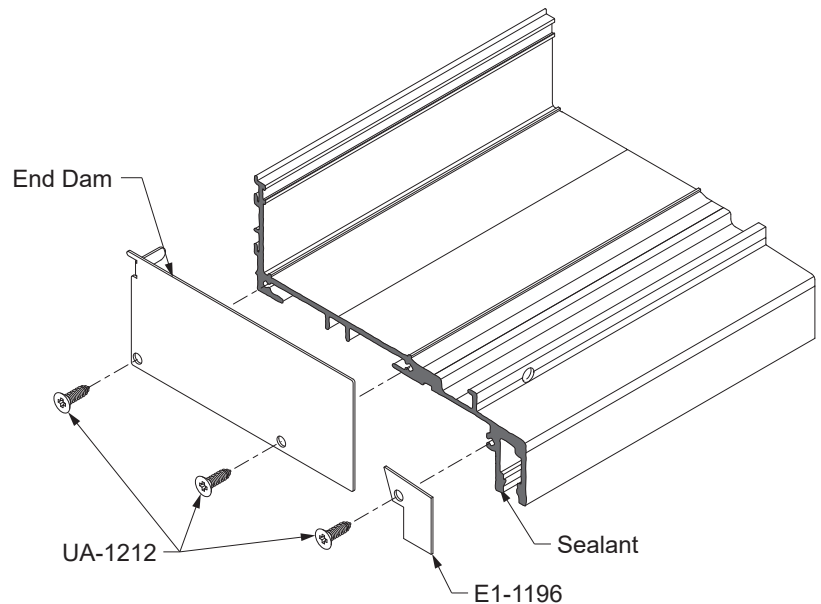
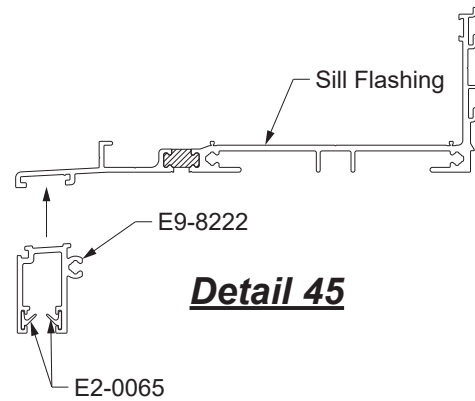

Detail 46

FRAME INSTALLATION

STEP 22

INSTALL BE9-2845/BE92846 (YWW 50 TU) OR BE9-2865/BE9-2866 (YWW 60 TU) SILL FLASHING

- Prior to installing the sill flashing, slide in E1-2853/E1-2854 strap anchors (2 per DLO) if they are being used.
- Install the sill flashing with a minimum of 3/8" shim space underneath. Sill flashing must be installed level.
- Anchor the sill flashing to the structure a maximum of 4" from each end and then 18" to 24" on center, per P.E. calculations, or per FPA drawings.
- Apply and tool sealant to cover the heads of all anchors and screws.

STEP 23

INSTALL SILL FLASHING SPLICE SLEEVE

- Remove the nub with a chisel or pliers on both sides of the splice joint 1-1/2" as shown in **Detail 47**.
- After the sill flashing has been shimmed and anchored to the building structure, insert a small backer rod under the sill flashing as shown in **Detail 48**.
- Position the Silicone Splice Sleeve against the back wall below the groove.
- Bend the Silicone Splice Sleeve into the front on the channel as shown. Mark and cut the sleeve at this position.
- Clean Sill Flashing and Silicone Splice Sleeve with isopropyl alcohol at the splice location.
- Seal the flashing at the splice location as shown in **Detail 48**, before positioning the flashing. Set the Silicone Splice Sleeve into the sealant.
- Tool sealant tight as shown in **Detail 48**, squeezing the sheet flat with a seam roller.

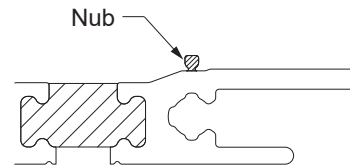

Detail 47

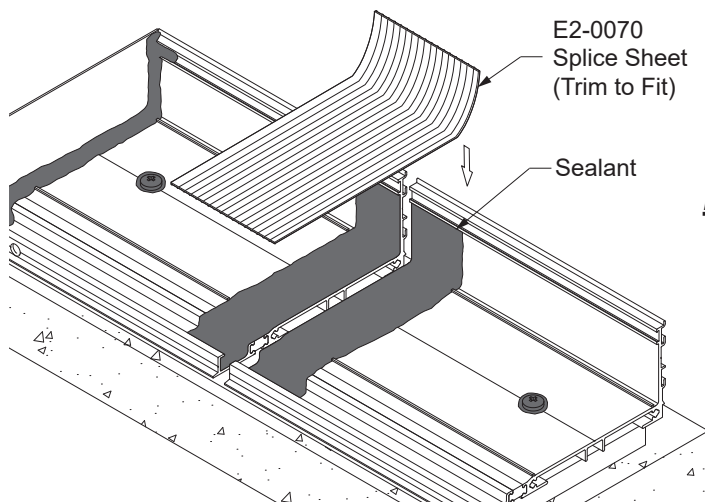
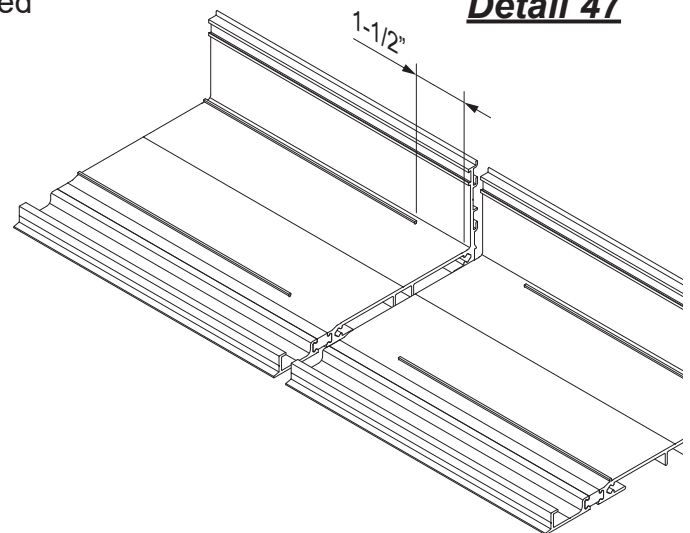

Detail 48

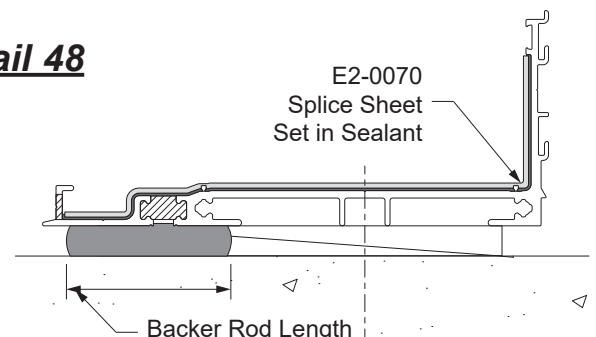

FRAME INSTALLATION**STEP 23 (Continued)****INSTALL SILL FLASHING SPLICE SLEEVE**

-Thoroughly seal the small joint directly in front of the Silicone Splice Sleeve as shown in **Detail 49**.

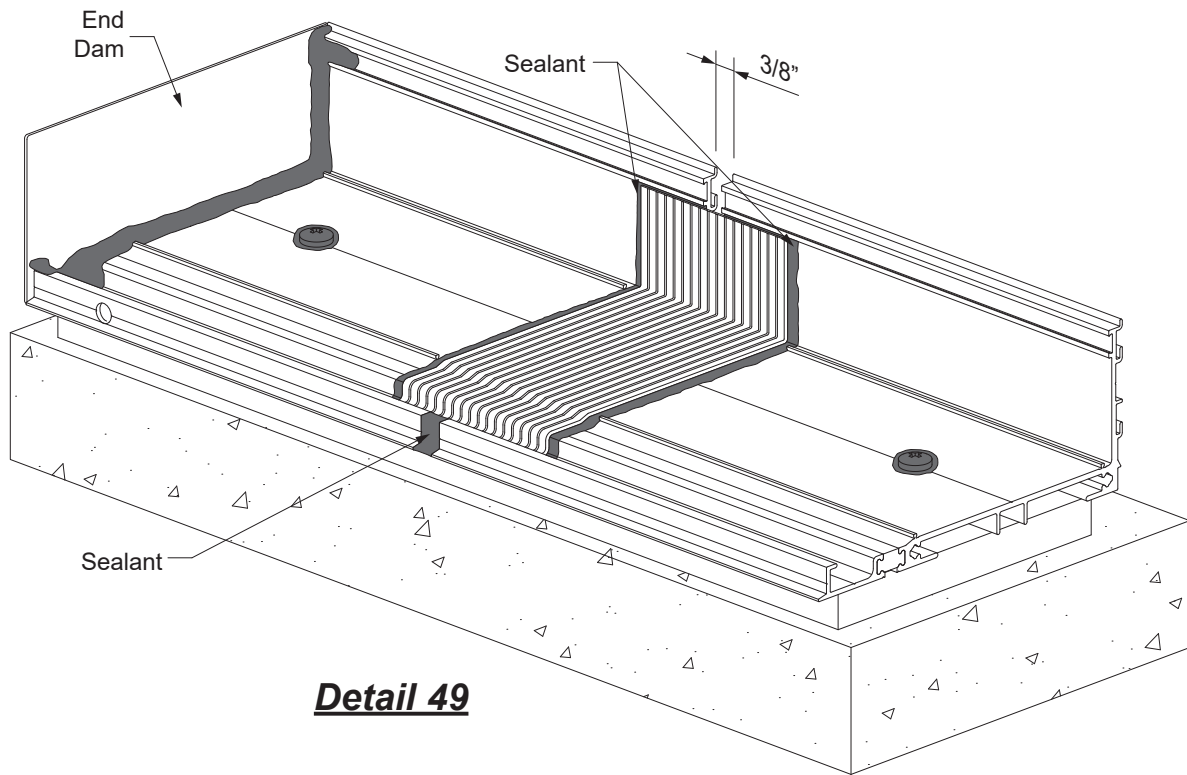

FRAME INSTALLATION

STEP 24 SLAB EDGE COVER INSTALLATION

Slab edge covers are installed from the head of the lowest elevation on upward. The head receptors are installed first, then slab edge plates, then the BE9-2846/BE9-2866 sill flashings with E9-8222 slab edge adaptors.

STEP 24A INSTALL HEAD RECEPTOR END DAMS & WEATHERING GASKETS

- Clean all joint surfaces using cleaner approved by sealant manufacturer.
- Apply sealant to the end of the head receptor as shown in **Detail 50**.
- Fasten the end dam to the head receptor with two UA-1212 screws, starting at the back, followed by the front.
- Tool sealant along the joint between the end dam and the end dam as shown in **Detail 50**.
- Tape down the top corners to hold the end cap in place until the sealant cures.

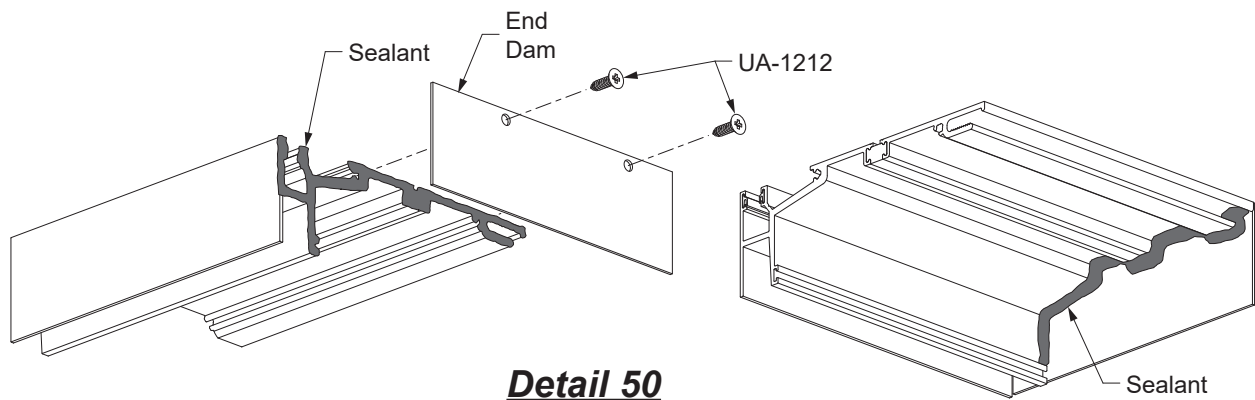

Detail 50

- Cut the E2-0051 airtight gasket to head receptor length plus 3/16" at each end for the splice joint, and insert it into its reglet for both the receptor and snap cover as shown in **Details 51 & 51A**.
- Cut the E2-0065 slab edge weathering gaskets to head receptor length. Insert the gaskets into the slab edge reglets in the orientation as shown in **Details 51A**.

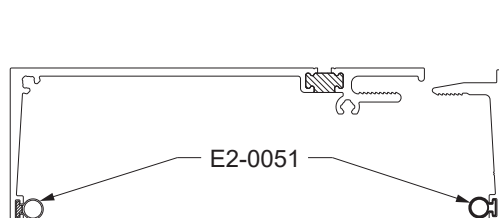

Detail 51

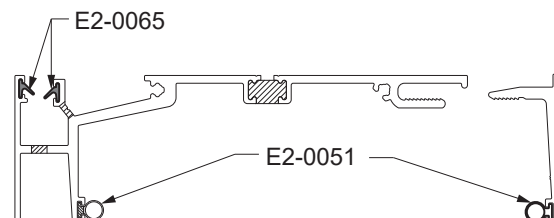

Detail 51A

FRAME INSTALLATION**STEP 24B
INSTALL HEAD RECEPTOR**

- Starting at the smallest opening height, install the head receptor with a minimum of 1/2" shim underneath. Head receptor must be installed level.
- Anchor the head receptor to the structure according to approved shop drawings and or P.E. calculations.
- Apply and tool sealant to the heads of all fasteners as shown on **Detail 52**.

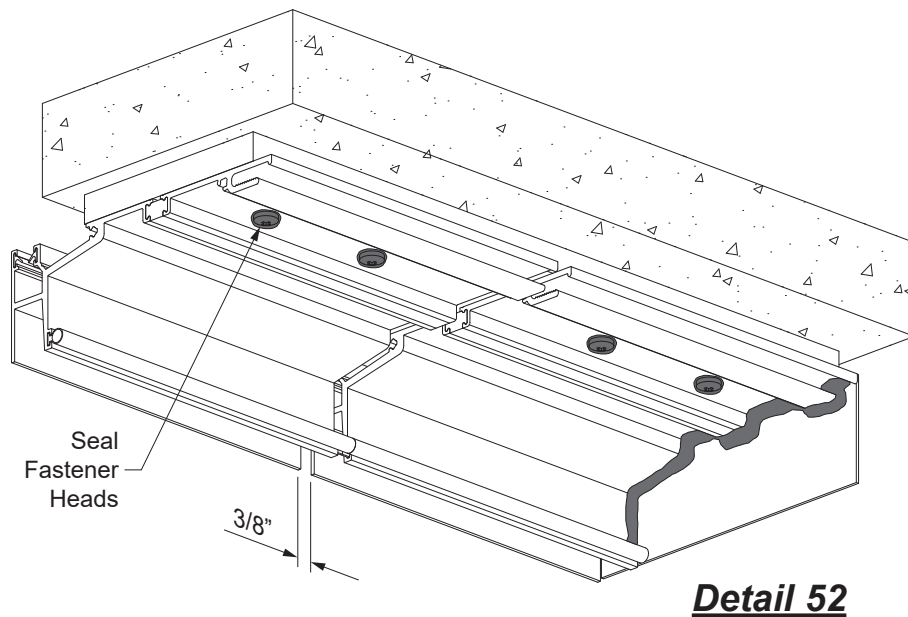

FRAME INSTALLATION

**STEP 24B (Continued)
INSTALL HEAD RECEPTOR**

-Prior to installing the Splice Sleeve, clean head receptor and Splice Sleeve with isopropyl alcohol at the splice location.

-Refer to the splice chart at the right for proper splice selection per head receptor used.

System	Head Receptor	Splice
YWW 50 TU	BE9-7635	E2-0070
YWW 50 TU	BY7-8426	E2-0070
YWW 50 TU	BE9-2819	E1-2813
YWW 60 TU	BE9-7736	E2-0070
YWW 60 TU	BE9-7299	E1-9824

- Position the Splice Sleeve against the front wall inside the head receptor, set in sealant centered on the splice joint as shown in **Detail 53**. For E2-0070 sheet, trim as necessary to fit.
- Tool the sealant. For E2-0070 sheet, use a seam roller to press the sheet tight against the receptor.
- Seal the ends of the E2-0051 together at the splice.

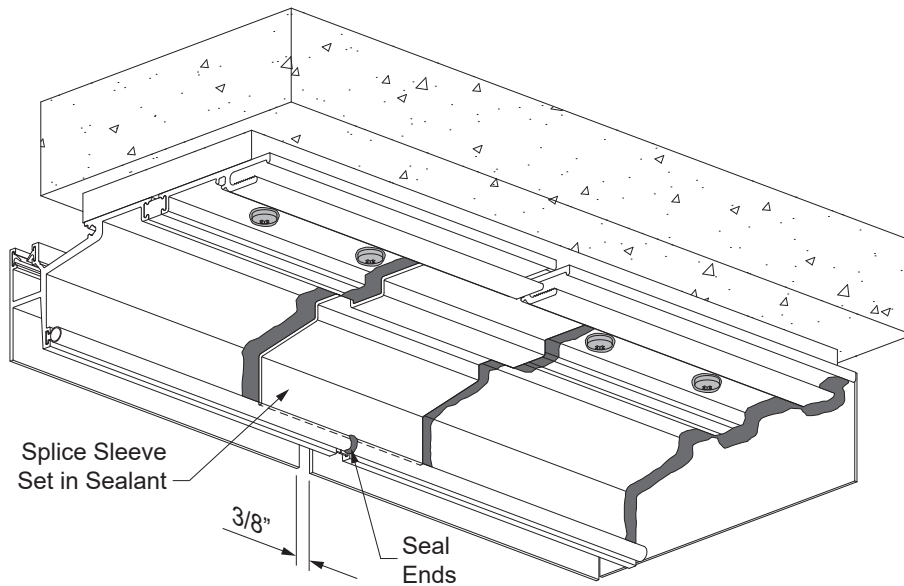

Detail 53

FRAME INSTALLATION**STEP 24B (Continued)****INSTALL HEAD RECEPTOR SPLICE SLEEVE**

-At the slab edge receptacle of the head receptor, position an E1-9961 splice sleeve centered on the splice joint. Set the splice sleeve in sealant, similar to the procedure previously outlined for the underside of the head receptor.

See **Detail 54**.

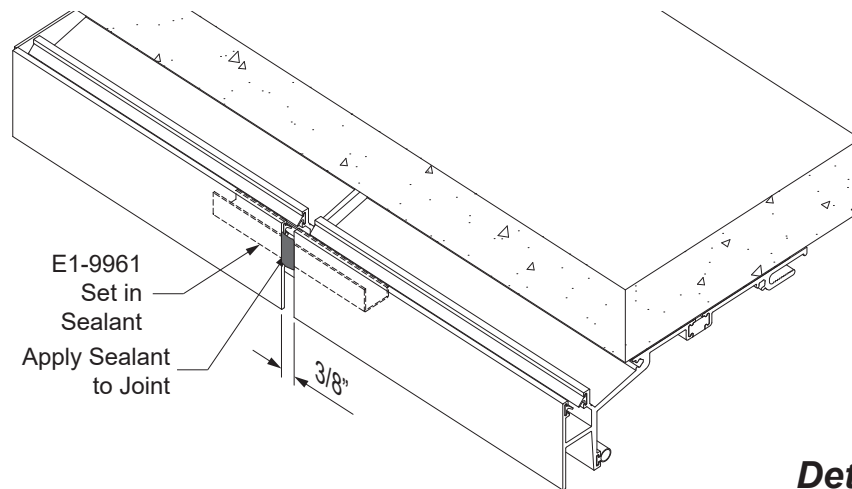

Detail 54

FRAME INSTALLATION

**STEP 24B (Continued)
INSTALL HEAD RECEPTOR GASKETS**

- Install E2-0054 setting blocks at 1/4 points of the aluminum plate.
- Install a weep baffle, E2-0099, over every weep hole location.

See **Detail 55**.

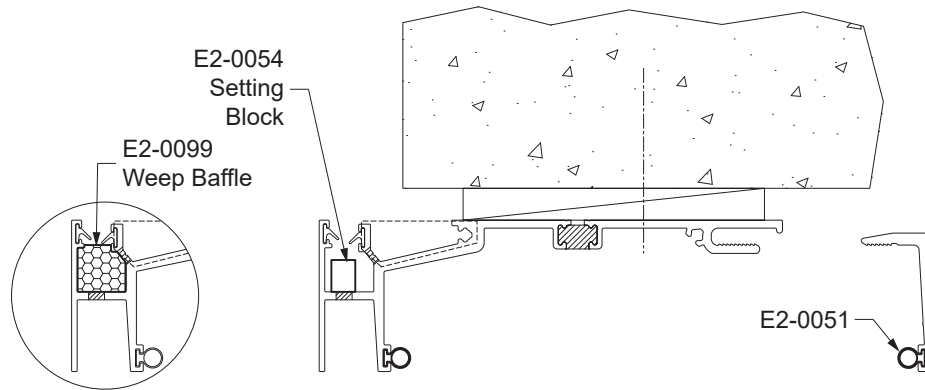

Detail 55

**STEP 24C
ASSEMBLE SLAB EDGE COVER PLATES**

- Clean the ends of the slab edge cover and attachment areas of end caps using a cleaner approved by sealant manufacturer.
- Apply and tool sealant to each end of the slab edge cover prior to attaching the end caps.
- Attach end caps to each end of the slab edge cover using (2) UA-1212 fasteners.
- Tool and wipe away any excess sealant at the joints.

See **Detail 56**.

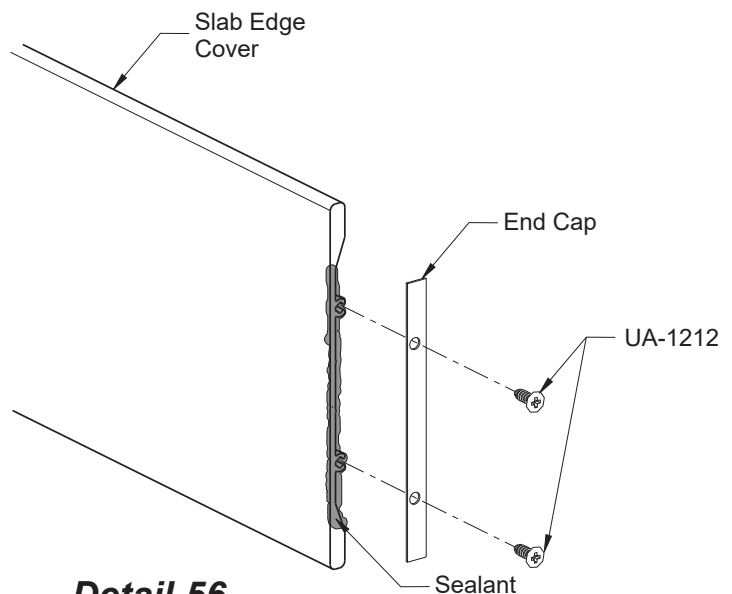

Detail 56

FRAME INSTALLATION

**STEP 24D
INSTALL SLAB EDGE COVER FASCIA**

- Prior to installing the slab edge cover, insert a continuous backer rod, and apply and tool sealant to the front underside of the slab edge, between the head receptor and the substrate.
- Slide the slab edge cover plate into the head receptor receptacle, seating it on top of the setting blocks.
- Be sure to leave a 3/8" joint between the plates for runs longer than 24'-0".

See **Detail 57**.

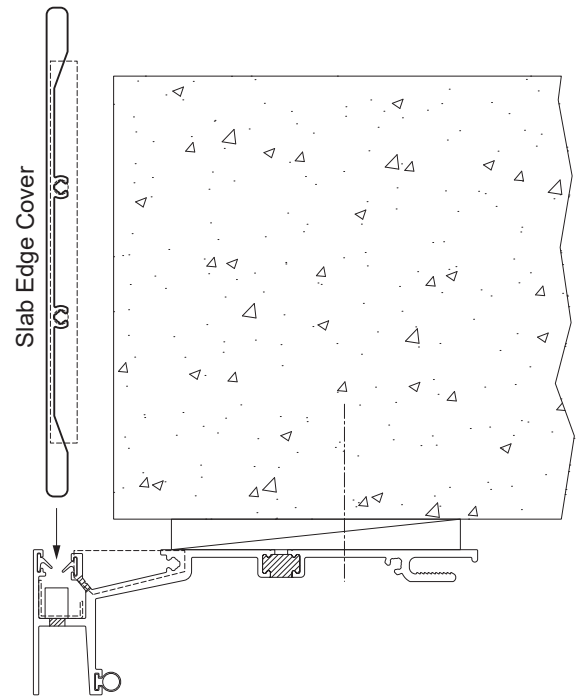

Detail 57

**STEP 25E
INSTALL SILL FLASHING SPLICE SLEEVE FOR
SLAB EDGE COVER**

- Before installing the sill flashing, install an E1-9959 splice sleeve at the underside of the sill flashing and slab edge adaptor.
- Apply bond breaker tape down the middle of the splice sleeve and sealant to one side of the splice sleeve as shown in **Detail 58**.
 - Adhere the sealed half of the splice sleeve to the underside of the sill flashing.

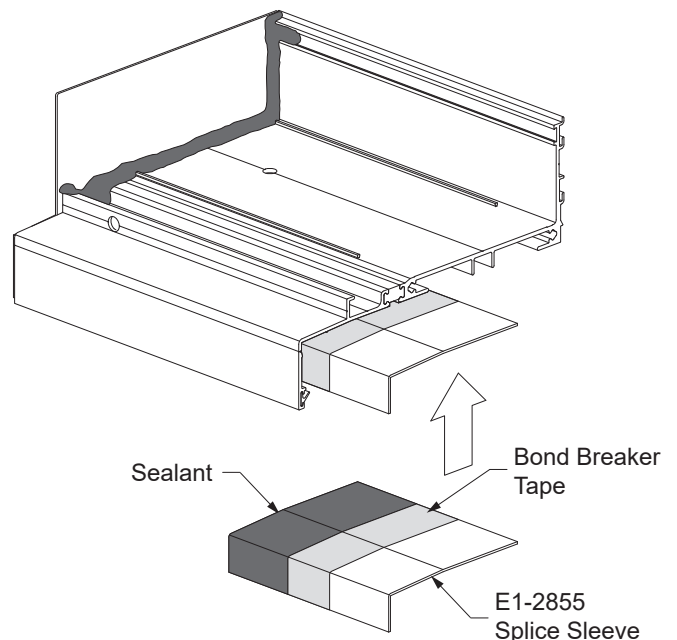

Detail 58

FRAME INSTALLATION

STEP 24E (Continued)

INSTALL SILL FLASHING SPLICE SLEEVE AT SLAB EDGE

- Install the sill flashing assembly onto the substrate, with a minimum 1/2" shim space, engaging the slab edge cover plates below and sealing all anchor fastener heads.
- Install the next slab edge sill flashing assembly onto the splice sleeve as shown in **Detail 59**. Be sure to leave a 3/8" splice joint between the sill flashing assemblies.

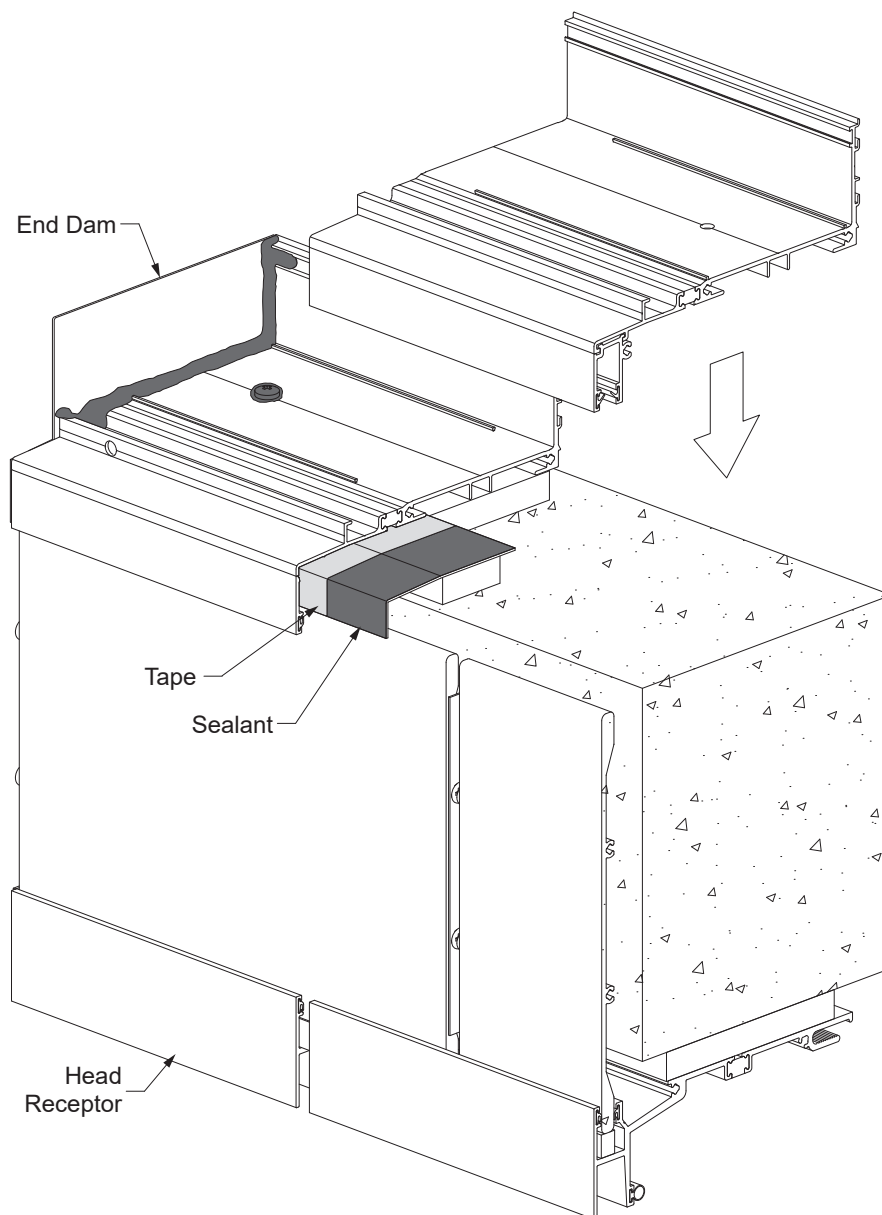

Detail 59

FRAME INSTALLATION

STEP 24E (Continued)

INSTALL SILL FLASHING SPLICE SLEEVE AT SLAB EDGE

-Installation of the E2-0070 splice sleeve is the same as previously outlined in **Step 23**, except to apply sealant to the joint at the slab edge cover plate, adaptor, and head receptor as shown in **Detail 60**.

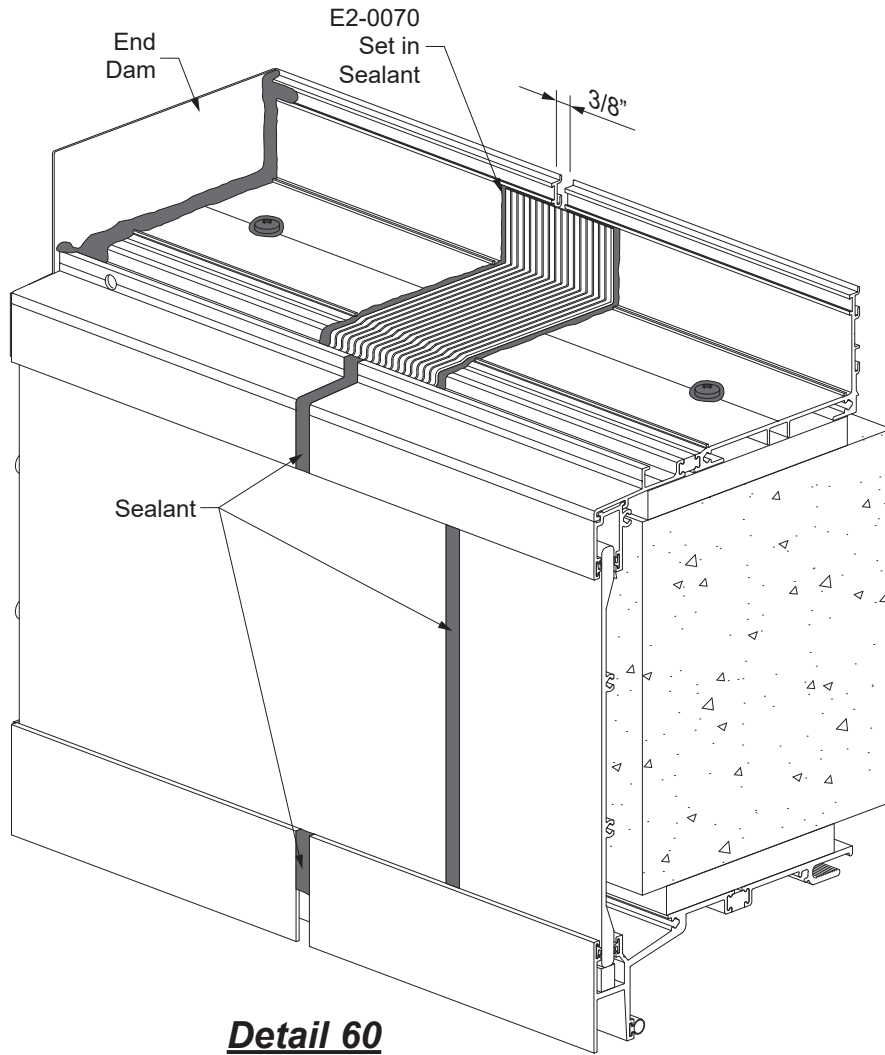

Detail 60

FRAME INSTALLATION

STEP 25

INSTALL BE9-2845 / BE9-2865 SILL FLASHING AT CORNERS

- Cut two 12" long pieces of sill flashing and miter(45° for 90° corners).
- Align the two pieces at the corner condition with the mitered ends pushed together tight and anchor the sill flashing as indicated on the approved shop drawings and or P.E. calculations.
- Apply and tool sealant to the mitered joint and anchor heads.

See **Detail 61**.

-Continue installing the rest of the sill flashing providing a 3/8" expansion joint at splices as shown in **Step 22 & 23 on Page 43 & 44**.

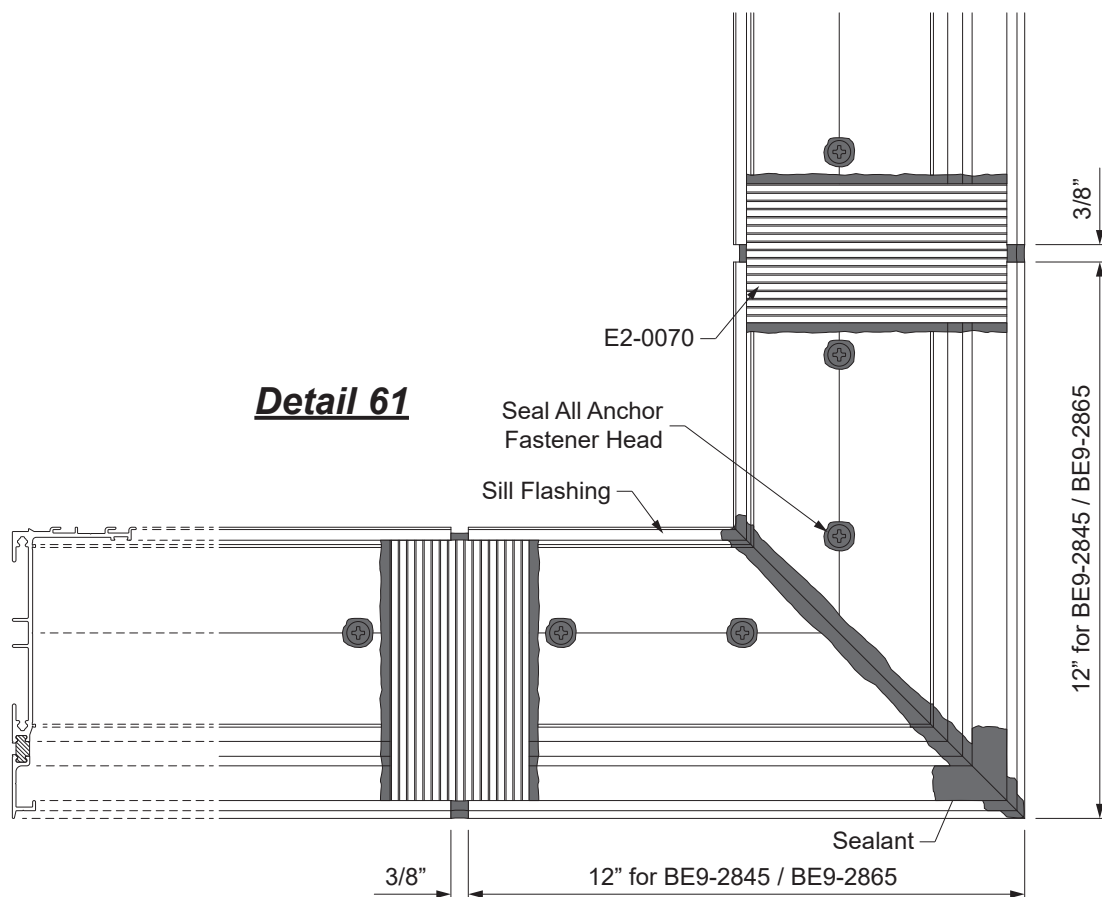

FRAME INSTALLATION

STEP 25A

INSTALL BE9-2846 / BE9-2866 SILL FLASHING AT CORNERS *

- Cut two 13-3/16" long pieces of BE9-2735 sill flashing and E9-8222 slab edge cover adaptor, and miter (45° for 90° corners). The head receptor that is to be installed below will also receive the same miter cut fabrication.
- Install the head receptor using similar procedure as previously described for the sill flashing.
- Miter cut the slab edge cover plates 45° for 90° corners, such that upon installation, they leave a 1/2" gap at the corner.
- Fasten end caps onto the edge of the slab edge cover plates.
- Install the slab edge plates onto the setting blocks of the head receptor below.
- Align the two pieces of the BE9-2735 sill flashing at the corner condition with the mitered ends pushed together tight and anchor the sill flashing as indicated on the approved shop drawings and or P.E. calculations.
- Apply and tool sealant to the mitered joint and anchor heads.

See **Detail 62**.

-Continue installing the rest of the sill flashing providing a 3/8" expansion joint at splices as shown in **Step 24 Pages 45 to 52**.

* **Note:** Similar technique required for head receptor.

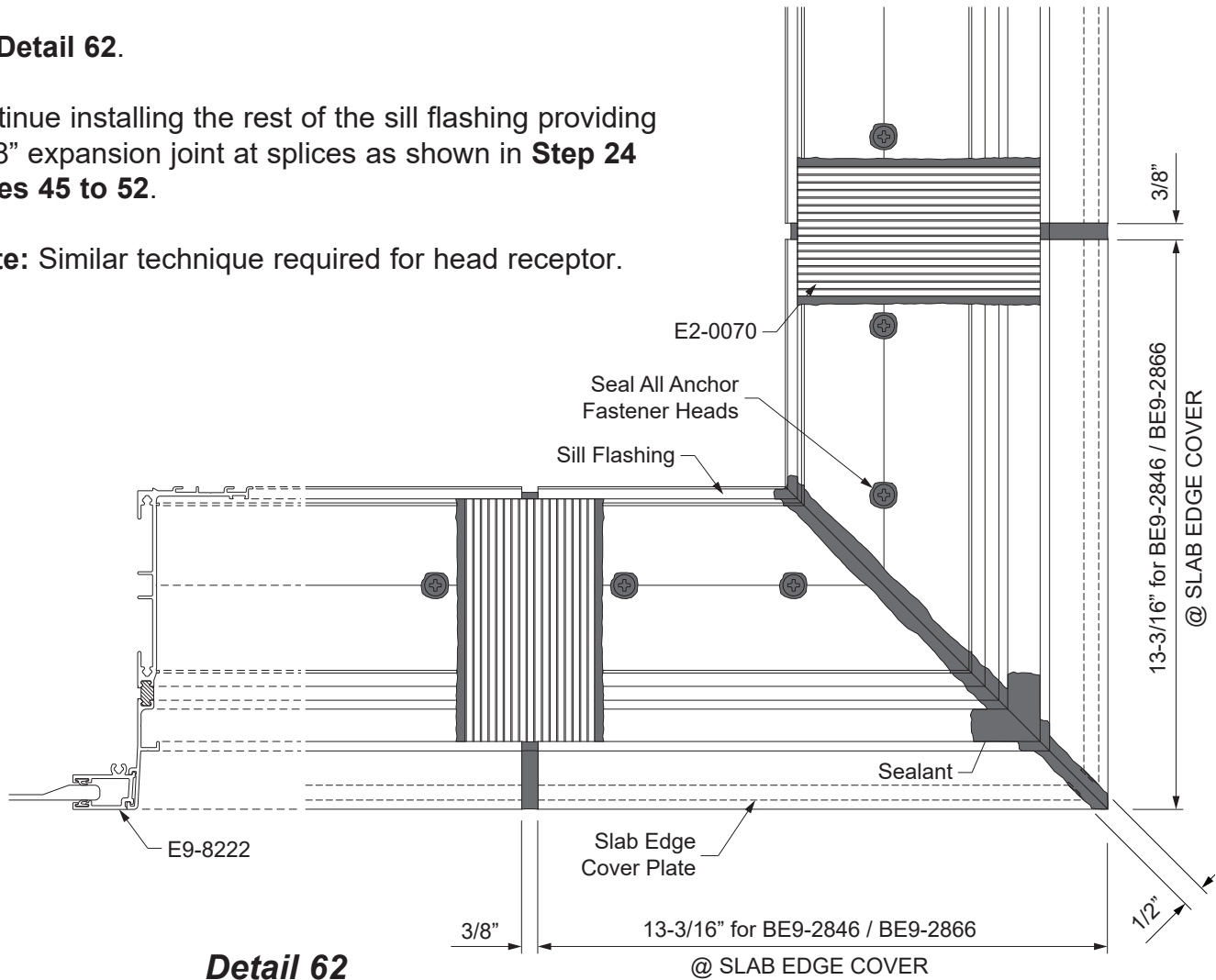

FRAME INSTALLATION

**STEP 27
INSTALL FRAMES**

- The female mullion half of the second unit engages into the male mullion half of the previously installed unit, from the side.
- For frames that utilize the E1-1190 channel shaped head anchor, secure the anchor to the head using masking tape as shown in **Detail 63** prior to installation into the frame opening.
- Set the frame into place. See **Detail 64** for shim space at head.
- Taking care to ensure the framing unit is plumb, level, square, and true, anchor the framing unit to the substrate, first at the head using fasteners as specified by engineering calculations.

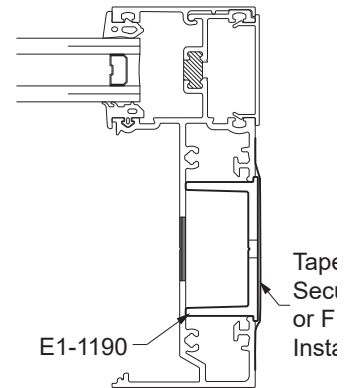

Detail 63

See **Detail 64**.

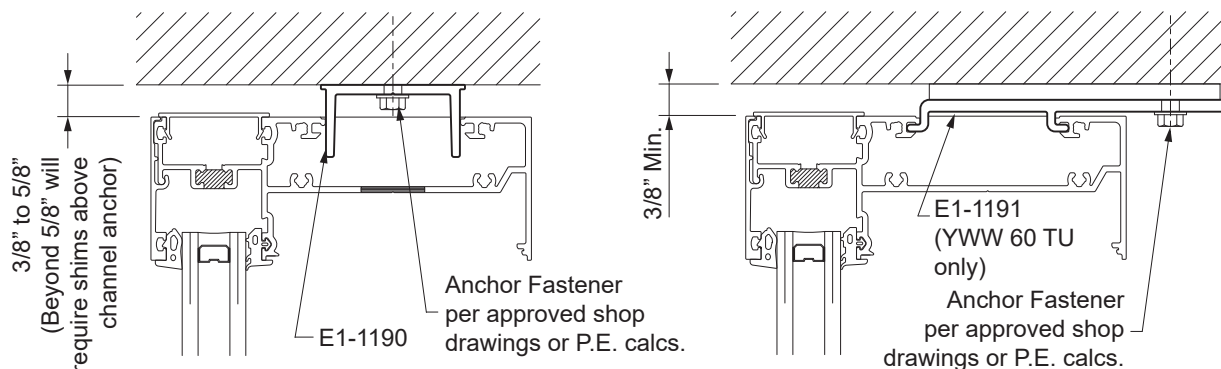

Detail 64

FRAME INSTALLATION**STEP 27 (Continued)
INSTALL FRAMES WITH
HEAD RECEPTOR**

- Set the frame into place, taking care to ensure the unit is plumb, level, square, and true.
- Snap on the receptor snap cover with the E2-0051 airtight gasket onto the head receptor.

See **Detail 65**.

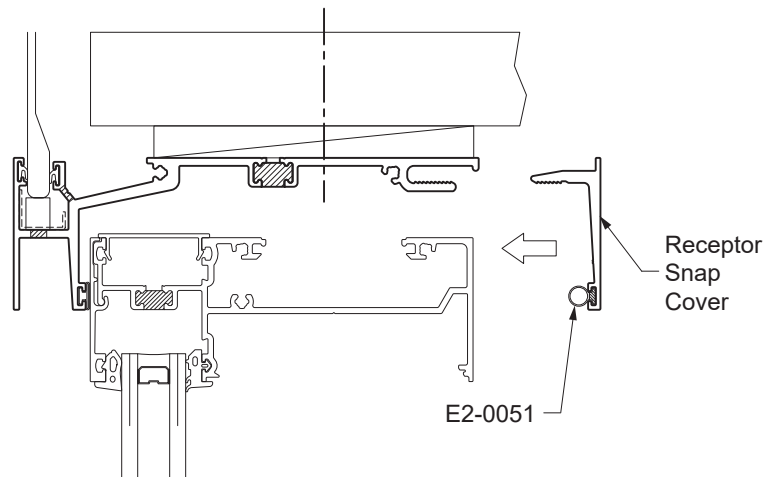

Detail 65

FRAME INSTALLATION

STEP 28 (Continued)
INSTALL FRAMES

-Fasten the sill to the sill flashing using seven (7) PM-1010 screws. Seal the screw heads. See **Detail 66**.

-Then anchor the jamb strap anchors to the substrate, if applicable.

-Just prior to installing the next unit, apply sealant to the interior reglet of the female mullion where it will interface with the male mullion of the installed unit (from bottom of mullion and 6" up.) See **Detail 67**.

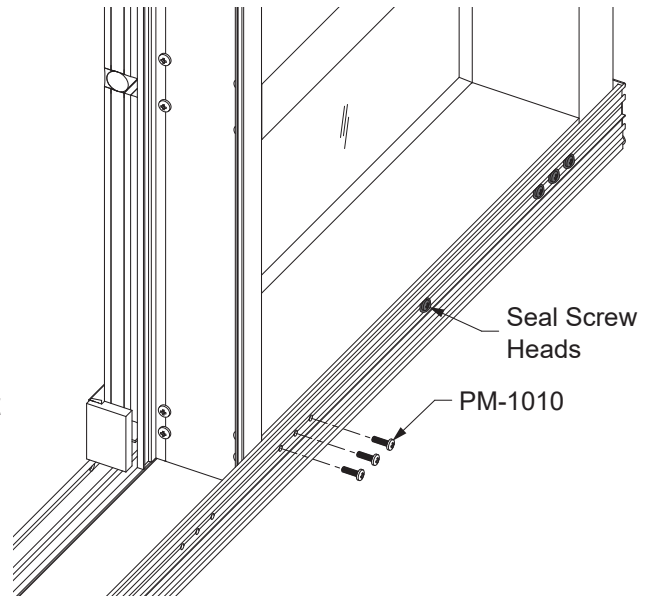

Detail 66

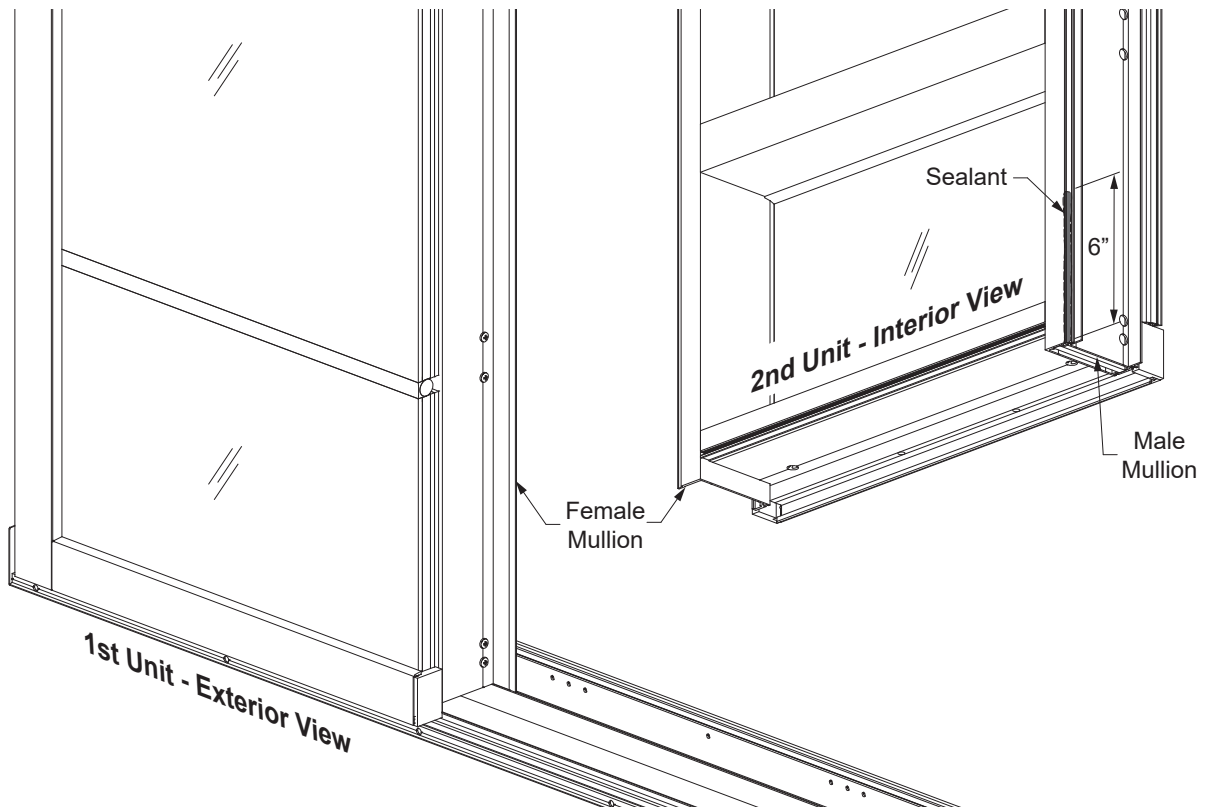

Detail 67

FRAME INSTALLATION**STEP 28 (Continued)
INSTALL FRAMES**

-Install the next framing unit, taking care to ensure that the unit is plumb, level, square, and true, and that the female mullion fully interfaces with the male mullion from the previous unit.

See **Detail 68 & 69**.

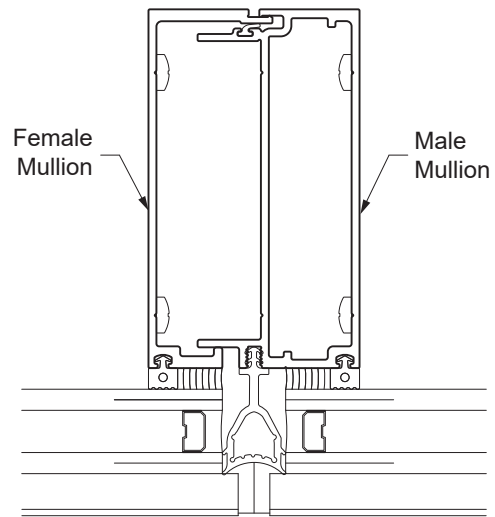

Detail 68

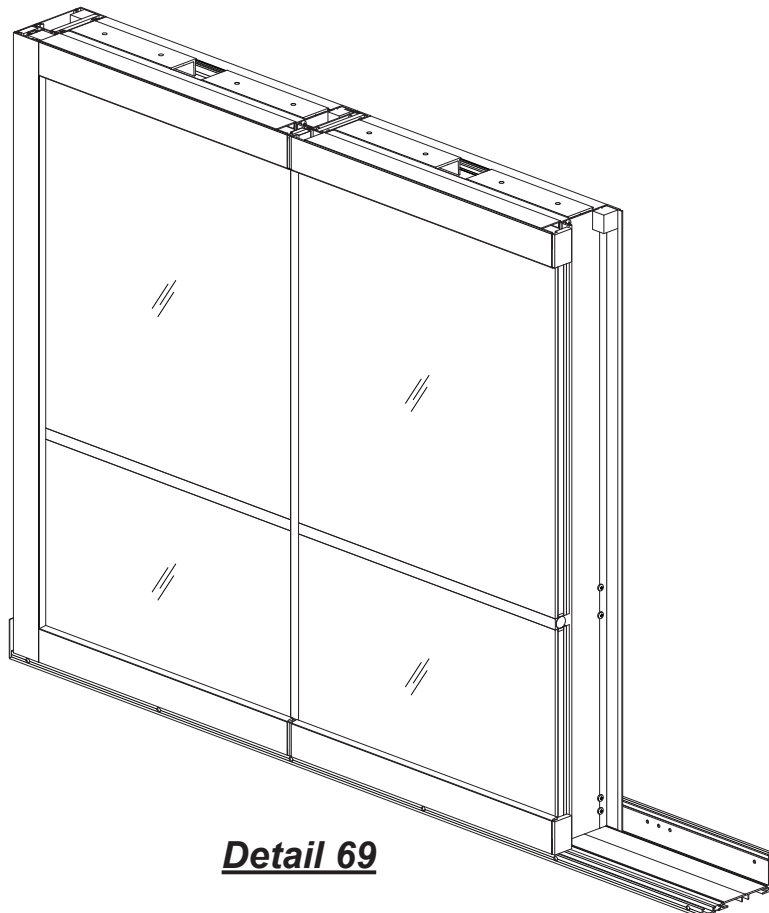

Detail 69

FRAME INSTALLATION

STEP 28 (Continued)
INSTALL FRAMES

-Fill the void between the two units at the back of the sill flashing with sealant.

See **Detail 70**.

-Repeat **Step 28** until all units are installed.

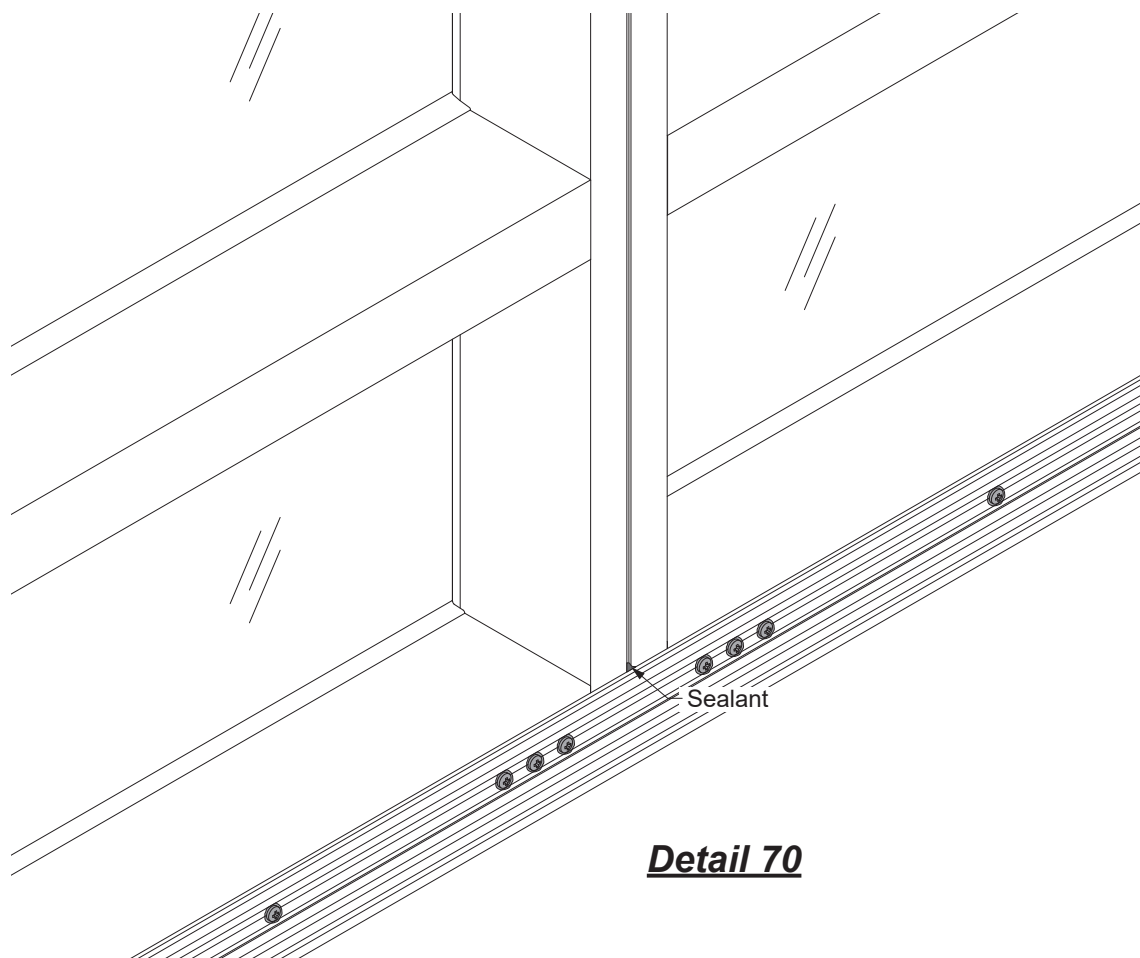

Detail 70

FRAME INSTALLATION

STEP 29

APPLY PERIMETER SEALANT

- Once all the units are installed, apply perimeter sealant required on interior and exterior of the window wall system.
- Install backer rod around the perimeter of the frame.
- Apply perimeter sealant to the joint between the frame and the structure.
- Avoid getting sealant into the sill flashing weep holes.

See **Detail 71**.

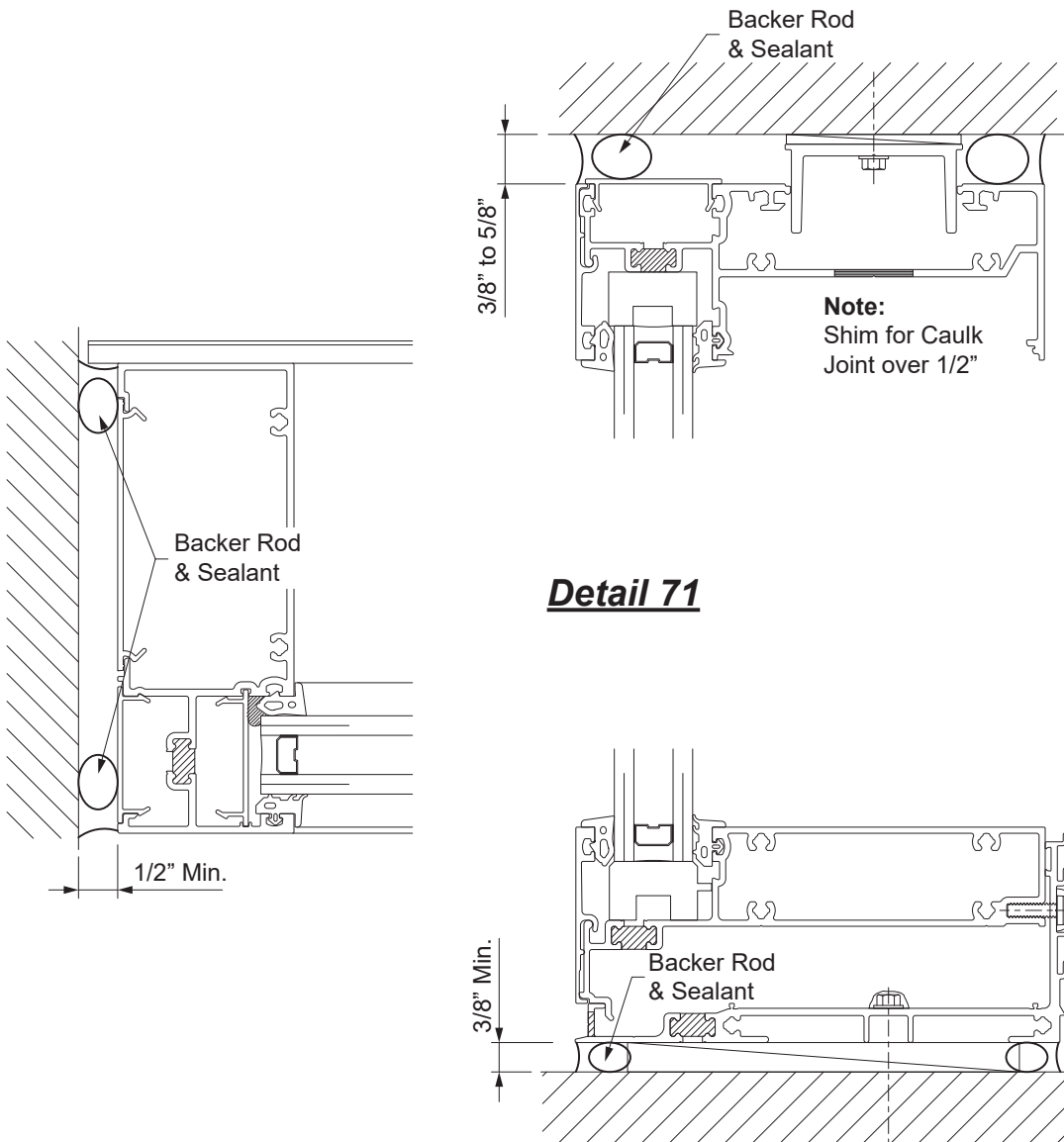

FRAME INSTALLATION

STEP 29A

APPLY PERIMETER SEALANT AT SLAB EDGE COVERS

- For slab edge covers at the head and sill, install a backer rod and apply sealant to the back of the sill flashing and head receptor.
- Tool sealant prior to skinning over.
- Install a backer rod and seal the jamb edge of the slab edge covers.

See **Detail 72**.

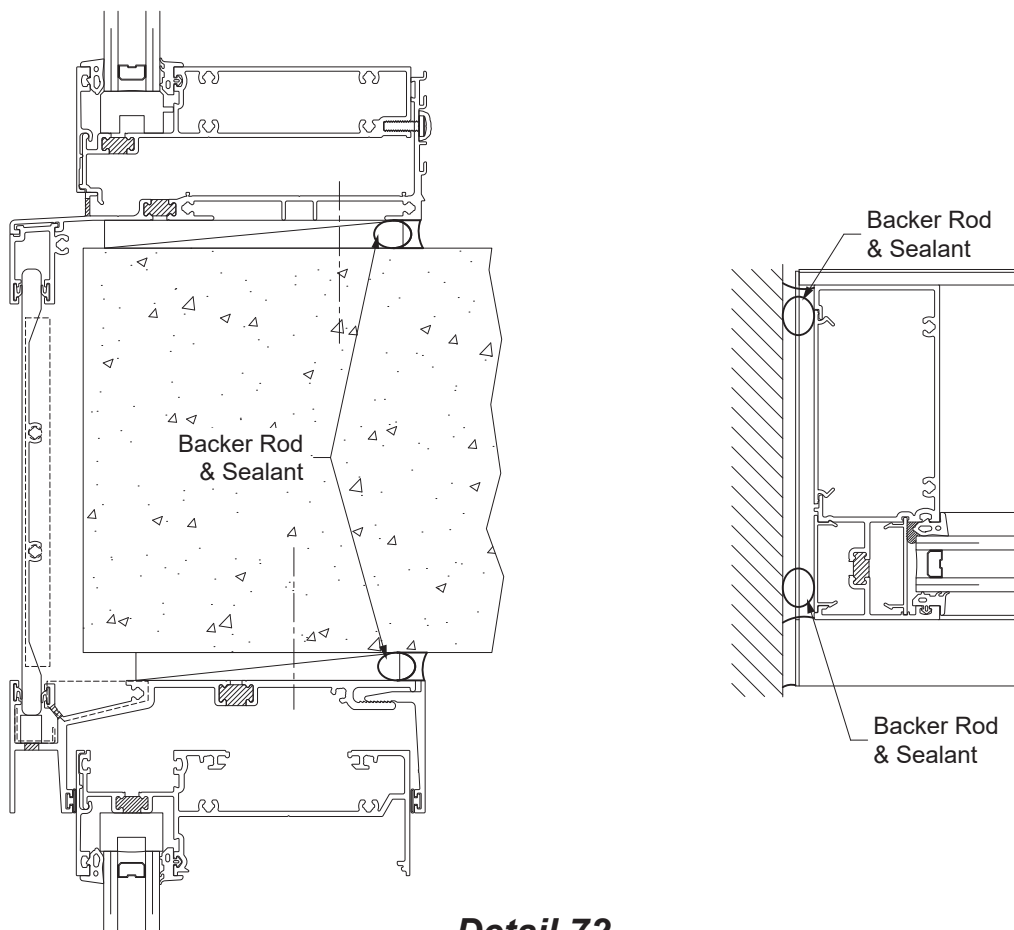

Detail 72

FRAME INSTALLATION**STEP 29B
APPLY SEALANT AT CORNER MULLIONS**

-Apply backer rod and sealant the at the interior of the corner mullion, the full height of the mullion.
Do not seal the exterior side.

See **Detail 73**.

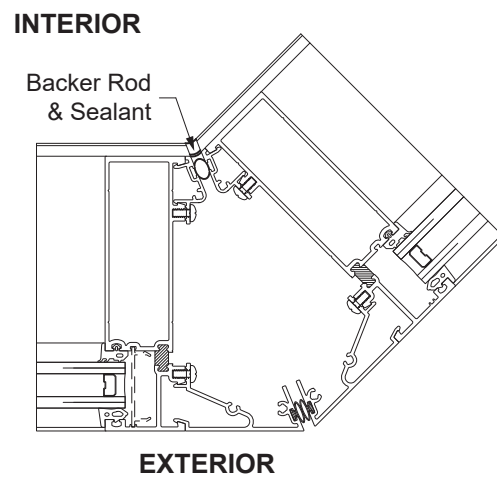
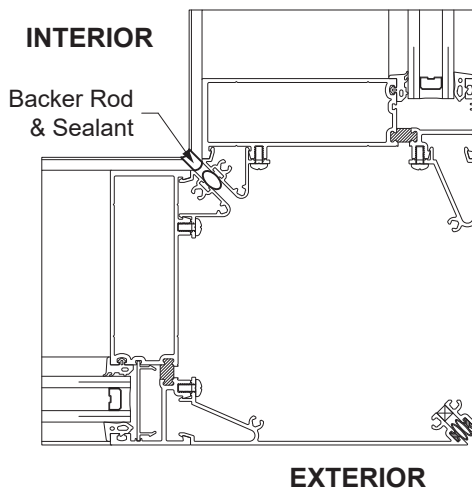

Detail 73

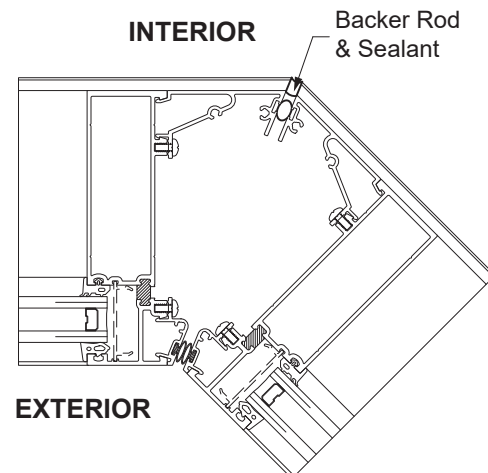
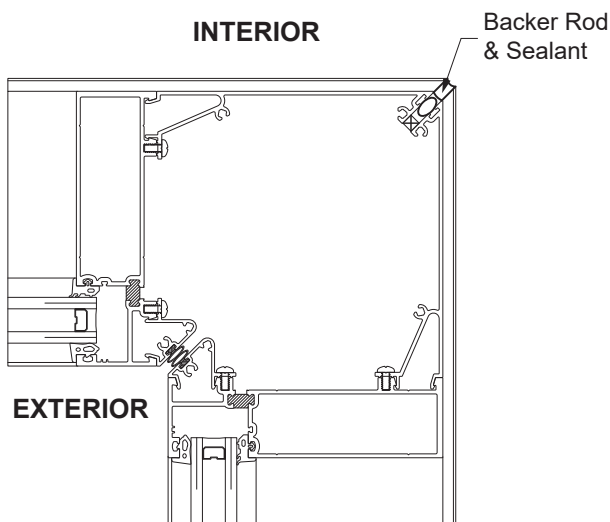

FRAME INSTALLATION

**STEP 30
INSTALL INTERIOR COVERS**

-Prior to snapping on the interior covers, cover the access holes for the head anchor fasteners by adhering cut pieces of E2-0070 sheets onto the head members with sealant.

-Snap on the interior covers at the heads.

YWW 50 TU
E9-2780 @ head

YWW 60 TU
E9-2762 @ head

See **Detail 74**.

-For all sill members, apply continuous sealant to the top of the back leg of the sill flashing as shown on **Detail 75**. Tool sealant and remove excess that would interfere with the installation of the interior cover. Then snap on the E9-2868 interior cover.

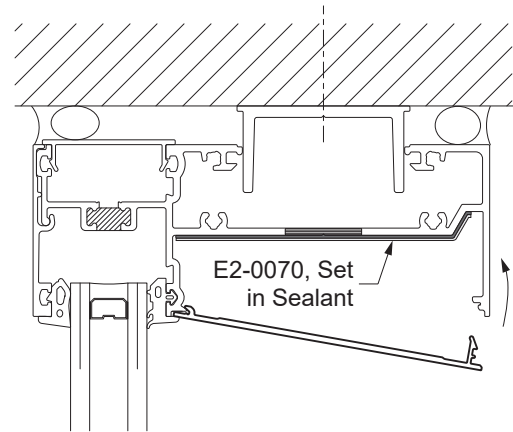

Detail 74

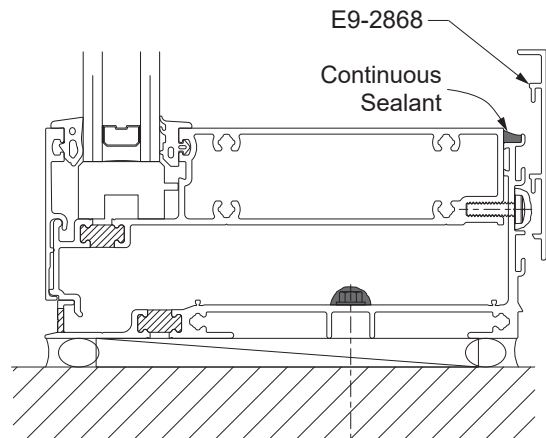

Detail 75

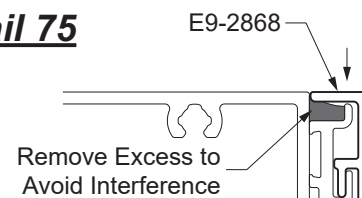

 **YKK AP America Inc.**

101 Marietta Street NW

Suite 2100

Atlanta, Georgia 30303

www.ykkap.com