

YWW 50 TU / YWW 60 TU Window Wall Installation Manual Field Glazed Captured

This instruction set is for the new sill flashing cover.
Please verify ordered material before proceeding.

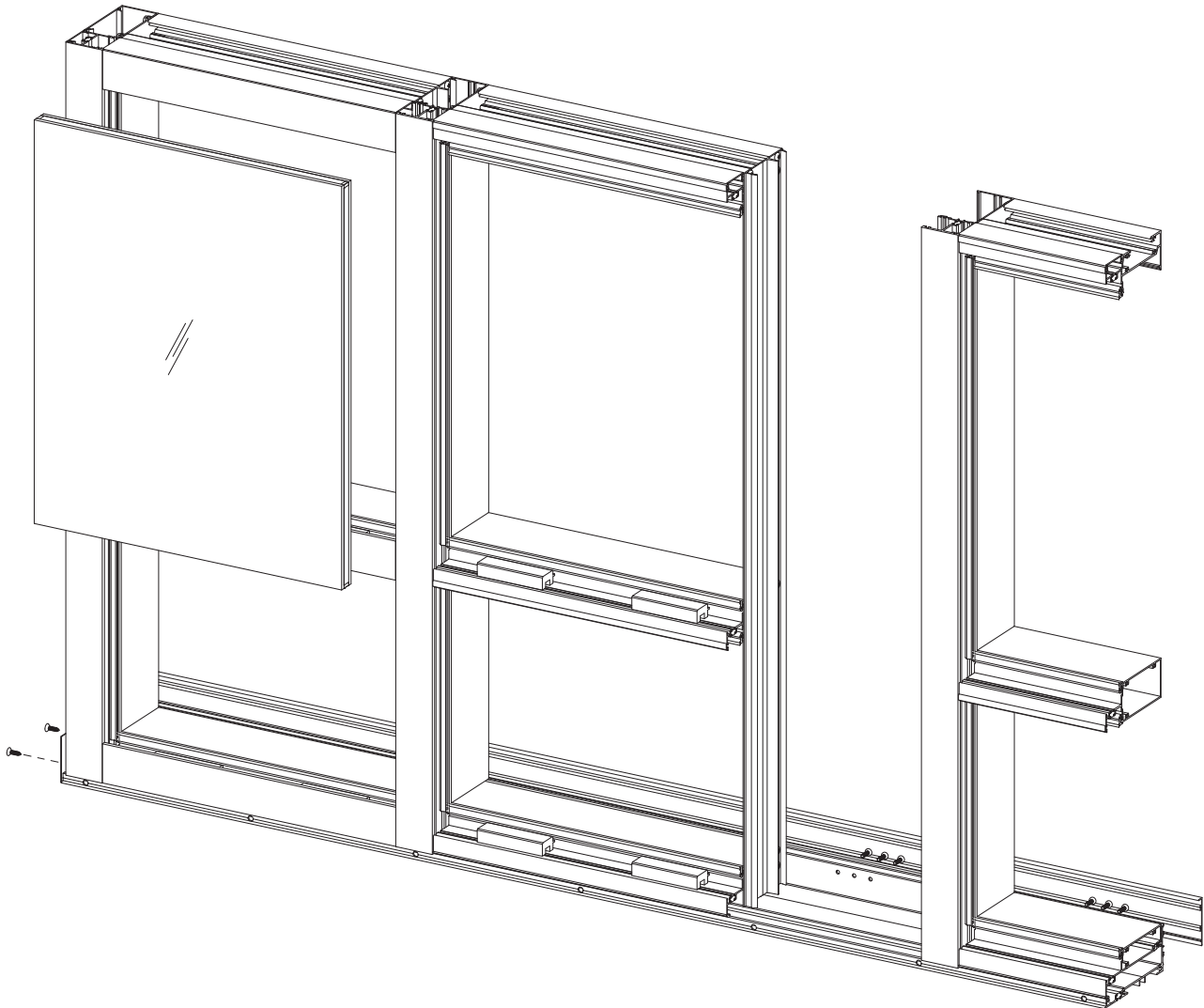

This page intentionally left blank.

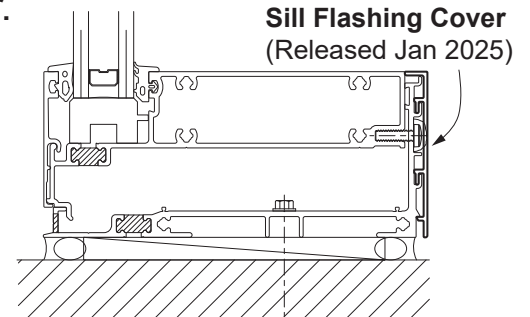
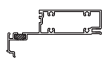

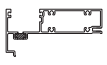



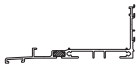
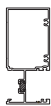





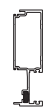



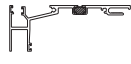



TABLE OF CONTENTS

Installation Notes	Page ii
PARTS DESCRIPTION	
YWW 50 TU Framing Members	Pages 1 & 2
YWW 60 TU Framing Members	Pages 3 & 4
Accessories	Pages 5 to 7
FRAME FABRICATION	
Determine Frame Size.....	Pages 8 & 9
Fabricate Vertical Members.....	Pages 10 to 13
Fabricate Horizontals.....	Pages 14 & 15
Fabricate Fillers & Glass Stops	Page 16
Fabricate Sill Flashing	Pages 17 & 18
Fabricate Corner Covers	Page 18
Fabricate Head Receptors.....	Page 19
FRAME ASSEMBLY	
Assemble Frame	Pages 20 to 22
Install Perimeter Fillers	Page 23
Install Foam Plugs at Head	Page 24
Install Sill Flashing End Dams.....	Pages 25 & 26
Install Sill Flashing.....	Page 27
Install Sill Flashing Splice Sleeve.....	Pages 27 & 28
Install Slab Edge Cover.....	Pages 29 to 37
Install Sill Flashing at Corners.....	Pages 37 & 38
Install Assembled Frames	Page 39
Anchor / Seal Frames.....	Pages 40 to 42
Install Water Deflector	Page 43
GLAZING	
Install Dart Gaskets	Page 44
Install Setting / Side Blocks	Page 45
Install Glass	Pages 46 & 47
Snap On Sill Flashing Cover.....	Page 48
DOOR FRAME INSTALLATION	
Install Door Frame	Pages 49 & 50
Glaze Door Transom	Page 51

Installation Notes

1. Do not drop, roll or drag boxes of aluminum framing. Move and stack boxes with proper support to prevent distortion. If fork lifts are used, be especially careful about striking the boxes when lifting or moving.
2. Store in a dry, out of the way area. If rain exposure, condensation or any water contact is likely, then all packaging material should be removed. Wet packaging materials will discolor and may stain aluminum finishes and paints.
3. All materials should be checked for quality and quantity upon receipt, YKK AP must be notified immediately of any discrepancies in shipment. Check to make sure that you have the required shims, sealants, supplies and tools necessary for the installation.
4. Carefully check the openings and surrounding conditions that will receive your material. Remember, if the construction is not per the construction documents, it is your responsibility to notify the general contractor in writing. Any discrepancies must be brought to the general contractor's attention before you proceed with the installation.
5. Gather your shop drawings, materials, packing list, and this installation manual. Carefully review parts location, the sequence it goes therein, when you glaze it and how you seal it. Installation instructions are of a general nature and may not cover every condition you will encounter. The shop drawings and/or installation manuals were prepared specifically for the product.
6. Any material substitutions must be of equal or greater quality.
7. Make certain that material samples have been sent for compatibility testing for all manufacturer's sealants involved. Make certain sealants have been installed in strict accordance with the manufacturer's recommendations and specifications.
8. Remember to isolate, in an approved manner, all aluminum from uncured masonry or other incompatible materials.
9. System-to-structure fasteners are not supplied by YKK AP. Fasteners called out on shop drawings are to indicate minimum sizes for design loading.
10. If any questions arise concerning YKK AP products or their installation, contact YKK AP for clarification before proceeding.
11. YKK AP storefront and/or curtain wall framing is typically completed before drywall, flooring and other products which may still be in process. Take the extra time to wrap and protect the work produced.
12. Cutting tolerances are plus zero, minus one thirty second unless otherwise noted.
13. Check our website, www.ykkap.com, for the latest installation manual update prior to commencing work.











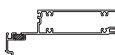

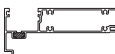



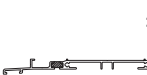



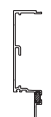

YWW 50 TU FRAMING MEMBERS

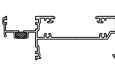
	Mullion 2-1/4" x 5"	BE9-2767		Sill (OG)	BE9-2843
	Tubular Mullion 2-1/4" x 5"	BE9-2791		Sill (IG)	BE9-2844
	Flat Filler Use with BE9-2767	E9-8715		Sill Flashing	BE9-2845
	Jamb 2-1/4" x 5"	BE9-2766		Sill Flashing for Slab Edge Cover	BE9-2846
	Jamb 2-1/4" x 5"	BE9-2790		Sill Flashing Interior Cover Used with BE9-2845 & BE9-2846	E9-2868
	Corner Mullion Half 2-1/4" x 5"	BE9-2779		Deep Sill Flashing Interior Cover Used with BE9-2845 & BE9-2846	E9-2869
	Female Mullion	BE9-2764		Strap Anchor Used with BE9-2845 & BE9-2846	E9-2847
	Male Mullion	BE9-2765		Head Receptor	BE9-7635
	Head (OG) 2-1/2" x 5"	BE9-2771		Optional Head Receptor	BY7-8426
	Head (IG)	BE9-2785		Head Receptor w/ Plate Adaptor	BE9-2819
	Horizontal (OG)	BE9-2789		Receptor Snap Cover Used with BE9-7635	E9-8720
	Horizontal (IG)	BE9-2786		HD Receptor Snap Cover Used with BE9-2819	E9-8157

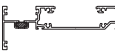
YWW 50 TU FRAMING MEMBERS

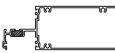
	90° Corner Cover (Large) E9-2783		7-7/8" Slab Edge Cover For Use with 7-7/8" Slab E9-8231
	90° Corner Cover (Small) E9-2741		8" Slab Edge Cover For Use with 7" Slab E9-8589
	135° Corner Cover (Large) E9-2784		9" Slab Edge Cover For Use with 8" Slab E9-8428
	135° Corner Cover (Small) E9-2743		Head Anchor E9-2732
	Glazing Adaptor for 1/4" Gl. E9-3340		Door Jamb Adaptor Subframe E9-2344
	Interior Glass Stop E9-2781		4-1/2" x 1-3/4" Door Head O/P For 20D/35D/50D Doors E2-0051 Included AS-0402
	Flush Filler E9-2780		Door Stop For 20D/35D/50D Doors E2-0051 Included Use with E9-2344 AS-0417
	Exterior Glass Stop E9-1715		Flat Filler BY7-9241
	Aluminum Plate Adaptor For BE9-2735 E9-8222		Door Jamb Adaptor Subframe For 25T/35T/50T Doors Use with AS-1539 BE9-1526
	6-1/8" Slab Edge Cover For Use with 5-1/8" Slab E9-8059		Door Head Subframe For 25T/35T/50T Doors E2-0051 Not Included BE9-2582
	6-5/8" Slab Edge Cover For Use with 5-5/8" Slab E9-7723		Door Stop For 25T/35T/50T Doors E2-0051 Included Use with BE9-1526 AS-1539
	7-3/8" Slab Edge Cover For Use with 6-3/8" Slab E9-8223		

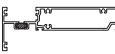









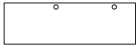
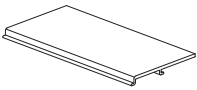

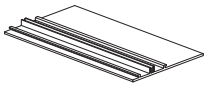
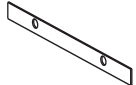
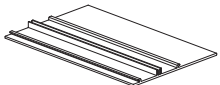
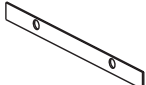

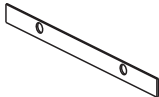

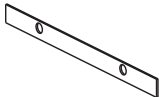
YWW 60 TU FRAMING MEMBERS

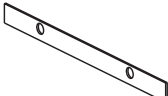
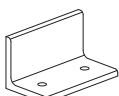
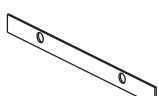
	Mullion	BE9-2749		Sill (OG)	BE9-2863
	Tubular Mullion 2-1/4" x 6"	BE9-2794		Sill (IG)	BE9-2864
	Flat Filler Use with BE9-2749	E9-7934		Sill Flashing	BE9-2865
	Jamb 2-1/4" x 6"	BE9-2748		Sill Flashing for Slab Edge	BE9-2866
	Tubular Jamb 2-1/4" x 6"	BE9-2793		Sill Flashing Interior Cover Used with BE9-2845 & BE9-2846	E9-2868
	Corner Mullion Half 2-1/4" x 6"	BE9-2761		Deep Sill Flashing Interior Cover Used with BE9-2845 & BE9-2846	E9-2869
	Female Mullion	BE9-2746		Head Receptor	BE9-7736
	Male Mullion	BE9-2747		Head Receptor w/ Plate Adaptor	BE9-7299
	Head (OG) 2-1/2" x 6"	BE9-2753		HD Receptor Snap Cover Used with BE9-7736 & BE9-7299	E9-8157
	Head (IG)	BE9-2787		90° Corner Cover (Large)	E9-2740
	Horizontal (OG)	BE9-2792		90° Corner Cover (Small)	E9-2741
	Horizontal (IG)	BE9-2788		135° Corner Cover (Large)	E9-2784

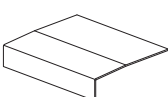
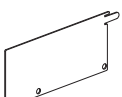
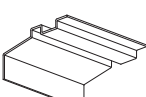

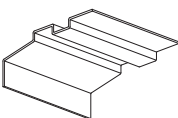







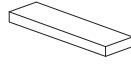







YWW 60 TU FRAMING MEMBERS

	135° Corner Cover (Small)	E9-2743		Strap Anchor	E9-2733
	Interior Glass Stop	E9-2763		Strap Anchor Used with BE9-2865 & BE9-2866	E9-2867
	Flush Filler	E9-2762		Head Anchor	E9-2732
	Exterior Glass Stop	E9-1715		Door Jamb Adaptor Subframe	E9-2344
	Aluminum Plate Adaptor For BE9-2735	E9-8222		4-1/2" x 1-3/4" Door Head O/P	AS-0402
	6-1/8" Slab Edge Cover For Use with 5-1/8" Slab	E9-8059		Door Stop For 20D/35D/50D Doors E2-0051 Included Use with E9-2344	AS-0417
	6-5/8" Slab Edge Cover For Use with 5-5/8" Slab	E9-7723		Flat Filler Use with BE9-2765	BY7-9241
	7-3/8" Slab Edge Cover For Use with 6-3/8" Slab	E9-8223		Door Jamb Adaptor Subframe For 25T/35T/50T Doors Use with AS-1539	BE9-1526
	7-7/8" Slab Edge Cover For Use with 7-7/8" Slab	E9-8231		Door Head Subframe For 25T/35T/50T Doors E2-0051 Not Included	BE9-2582
	8" Slab Edge Cover For Use with 7" Slab	E9-8589		Door Stop For 25T/35T/50T Doors E2-0051 Included Use with BE9-1526	AS-1539
	9" Slab Edge Cover For Use with 8" Slab	E9-8428			

ACCESSORIES

	Anchor 10" Cut Length	E1-1190		End Cap (YWW 60 TU) For BE9-7299 Slab Edge Head Receptor	E1-9822
	Head Strap Anchor 10" Cut Length For YWW 60 TU	E1-1191		End Cap For Slab Edge Sill Flashing Adaptor	E1-1196
	Sill Strap Anchor 10" Cut Length For YWW 50 TU	E1-2853		End Cap For E9-8059 Slab Edge Cover Plate	E1-9984
	Sill Strap Anchor 10" Cut Length For YWW 60 TU	E1-2854		End Cap For E9-7723 Slab Edge Cover Plate	E1-9985
	Jamb Strap Anchor 4" Cut Length For YWW 50 T	E1-1143		End Cap For E9-8223 Slab Edge Cover Plate	E1-9953
	Jamb Strap Anchor 4" Cut Length For YWW 60 T	E1-1149		End Cap For E9-8231 Slab Edge Cover Plate	E1-9954
	Door Jamb Mullion Anchor (1-7/8")	E1-1195		End Cap For E9-8589 Slab Edge Cover Plate	E1-9955
	Door Jamb Anchor (3-5/8")	E1-1199		End Cap For E9-8428 Slab Edge Cover Plate	E1-9956
	End Dam For YWW 50 TU Sill Flashing	E1-2851		Splice Sleeve For Sill Flashing at Slab Edge	E1-2855
	End Dam For YWW 60 TU Sill Flashing	E1-2852		Head Receptor Splice Sleeve (YWW 50 TU) For BE9-2819	E1-2813
	End Cap (YWW 50 TU) For BE9-7635 & BY7-8426 Head Receptor	E1-9841		Head Receptor Splice Sleeve (YWW 60 TU) For BE9-7299	E1-9824
	End Cap (YWW 50 TU) For BE9-2819 Slab Edge Head Receptor	E1-9952		Head Receptor Splice Sleeve For Slab Edge	E1-9961
	End Cap (YWW 60 TU) For BE9-7736 Head Receptor	E1-9855		Silicone Splice Sleeve	E2-0070

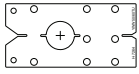
ACCESSORIES

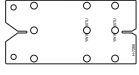
	Flat Filler PVC For YWW 50 TU	E3-0032		Setting Block for Intermediate Horizontals	E2-0178
	Flat Filler PVC For YWW 60 TU	E3-0023		Setting Block For Slab Edge Cover	E2-0054
	PVC Perimeter/Pocket Filler	E3-3664		Water Deflector	E2-0047
	Airtight Gasket	E2-0051		Foam Backer Tape 1" x 1-1/4" (Roll)	E2-0259
	Weather Seal Gasket For Mullion Halves	E2-7010		1/4" x 1/4" Spacer Tape	E2-0110
	Weathering Gasket For Slab Edge Cover	E2-0065		Dart Gasket 1/4" F.C.	E2-0801
	Anti-Walk Block For Female Mullion	E2-0546		Wedge Gasket 1/4" F.C.	E2-0808
	Side Block For Mullion	E2-0019		Weep Baffle	E2-0099
	Side Block For Male Mullion	E2-0133		Drill Fixture	H-7264
	Setting Block	E2-0150		Drill Fixture For Sill	H-7266

FASTENERS

	<p>#10" x 3/8" PHMS Stainless Steel, For Corner Cover Attachment</p>	<p>PM-1006 -SS</p>		<p>#12 x 2-1/2" FHSMS Type AB, Used at Door Transom Bar</p> <p>FC-1240</p>
	<p>#12 x 3/4" UFHSMS Type A, Zinc Plated Steel, For End Dam Attachment</p>	<p>UA-1212</p>		<p>#12 x 5/8" PHSMS Type AB, Zinc Plated Steel</p> <p>PC-1210</p>
	<p>#10-24 x 1/2" UCFH Type F, Stainless Steel</p>	<p>UF-1008- SS</p>		<p>#12 x 1" PHSMS Type AB, Zinc Plated Steel, Used at Male Mullion at Door Jamb</p> <p>PC-1216</p>
	<p>#12 x 1" FHSMS Type AB, Used with Jamb Strap Anchor</p>	<p>FC-1216</p>		<p>#12 x 1-1/4" PHSMS Type AB, Zinc Plated Steel</p> <p>PC-1220</p>
	<p>#12 x 1-1/2" FHSMS Type AB, Zinc Plated Steel, Used at Female Mullion at Door Jamb</p>	<p>FC-1224</p>		<p>#10 x 5/8" PHMS For Attachment of Sill to Sill Flashing</p> <p>PM-1010</p>

FRAME FABRICATION

STEP 1 DETERMINE FRAME SIZE

Determine Frame Width:

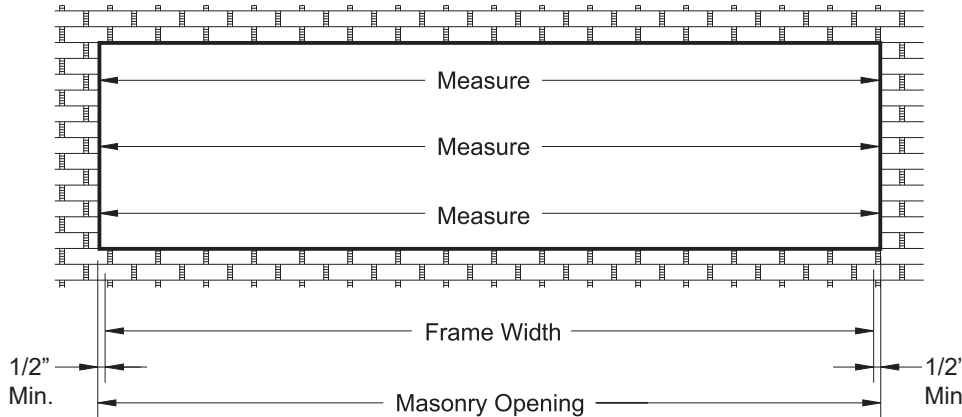

Note: Check opening for squareness of plumb at both ends, units must be installed in a true rectangle.

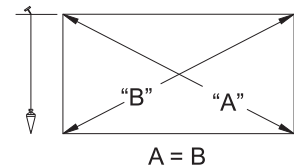

DETAIL 1

- Measure the width of the masonry opening at the top, middle, and bottom.
 - Select the smallest dimension measured and subtract 1" to determine the frame width.
- See **Detail 1**.

Note: For additional possibilities such as slab edge cover application, it is recommended to increase the caulk joint at the jambs to facilitate installation of the last framed unit. (Unit width will proportionally affect caulk joint width.)

Determine Frame Height:

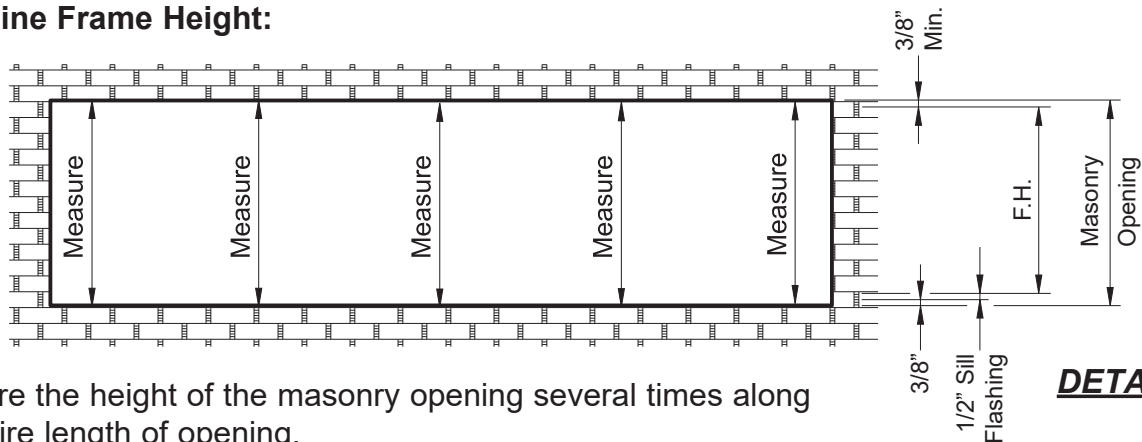

DETAIL 2

- Measure the height of the masonry opening several times along the entire length of opening.
- Select the smallest dimension measured and subtract 1-1/4" to determine the frame height to be used.
 - Minimum of 3/8" shim/caulk joint at the head.
 - 1/2" for the sill flashing.
 - Minimum 3/8" shim/caulk joint below the sill flashing.

See **Detail 2**.

Notes: Vertical through frame widths over 24'-0" require expansion mullions every 12 to 15 feet (best location at vertical next to door jamb.) *1-1/4" is based on 3/8" perimeter caulk joint, which can vary per project.

FRAME FABRICATION

STEP 1 (Continued)
DETERMINE FRAME SIZE

Determine Frame Height for Slab Edge Conditions:

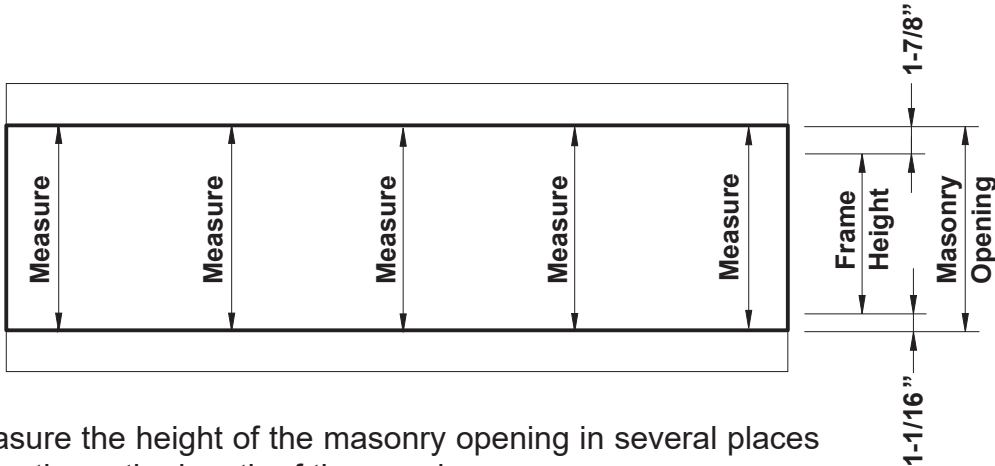

- Measure the height of the masonry opening in several places along the entire length of the opening.
- Select the smallest dimension measured and subtract *3" to determine the frame height to be used:
 - 5/8" for the shim/caulk joint at the head.
 - 1-1/4" for the head receptor.
 - 1/2" for the sill flashing.
 - 5/8" for the shim/caulk joint below the sill flashing.

Detail 3

See **Detail 3**.

* **Note:** 3" is based on 5/8" perimeter caulk joint, which can vary per project.

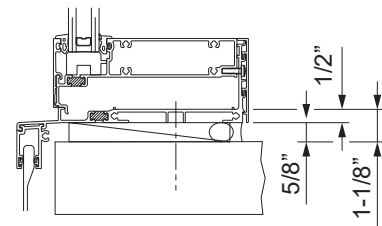
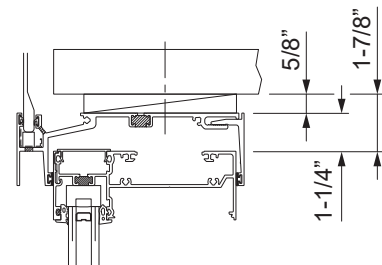

FRAME FABRICATION

STEP 2 FABRICATE VERTICAL MEMBERS

- Cut all jamb and two piece vertical members to the frame height determined in **Step 1**.
 - Fabricate holes in the vertical members for screw spline attachment using one of the methods below:
 - Using the H-7264 and H-7266 drill fixture as a template, line up the glazing pockets and mark hole locations through the screw splines of the templates.
 - OR**
 - Layout hole locations on vertical members as shown in **Detail 4**.
- Drill 0.236" diameter (#B drill bit) holes at each location marked.

Notes: Additional fabrication will be required for the inclusion of steel reinforcing. Drill fixture plate can be used.

* A 5/16" diameter access hole can be used at the very top to eliminate sharp edges.

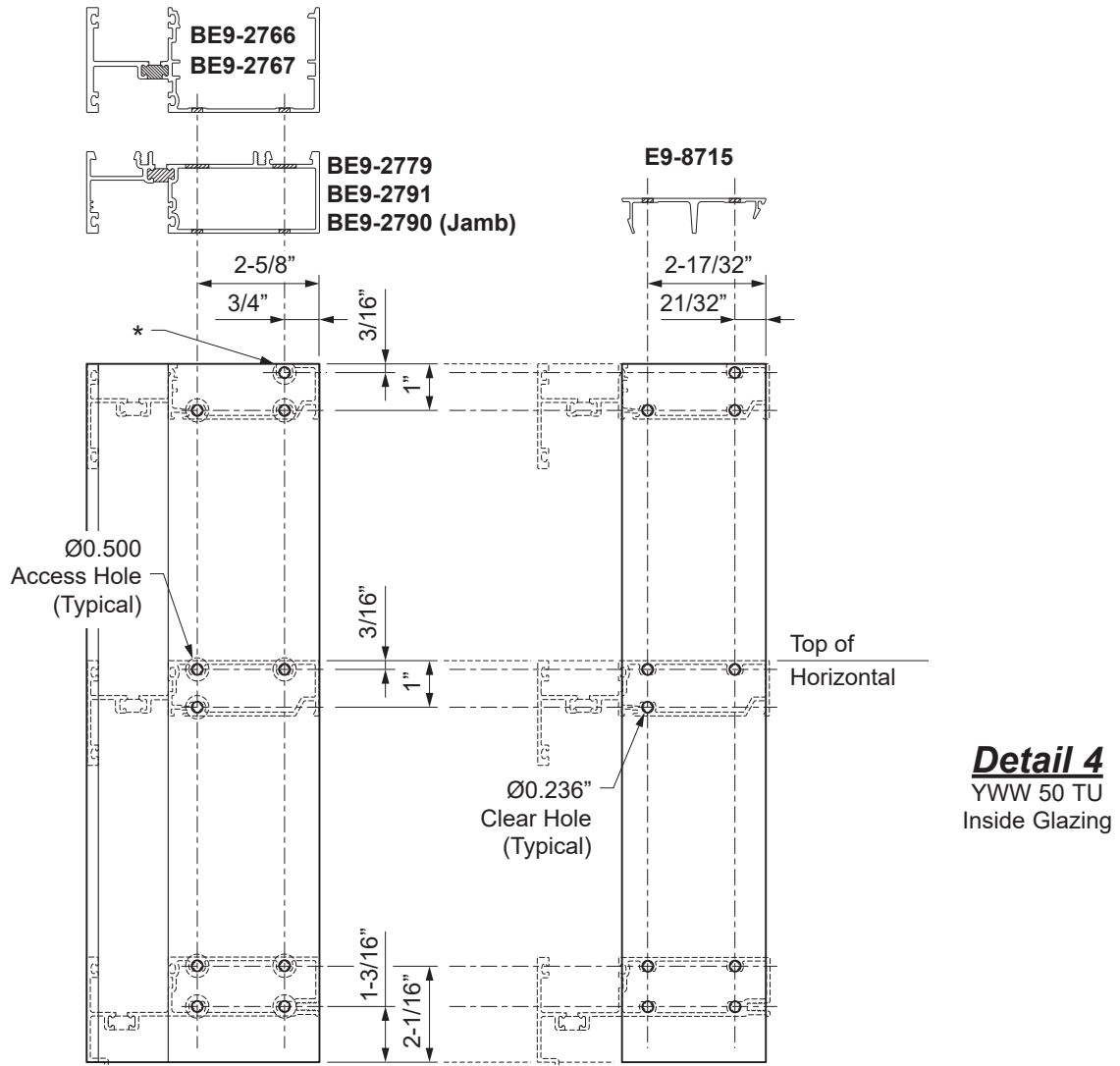

Detail 4
YWW 50 TU
Inside Glazing

FRAME FABRICATION

STEP 2 (Continued)
FABRICATE VERTICAL MEMBERS

-For hollow vertical members, fabricate access holes in addition to the clear holes according to the methods previously shown and in **Detail 5**.

Notes: Additional fabrication will be required for the inclusion of steel reinforcing.

* A 5/16" diameter access hole can be used at the very top to eliminate sharp edges.

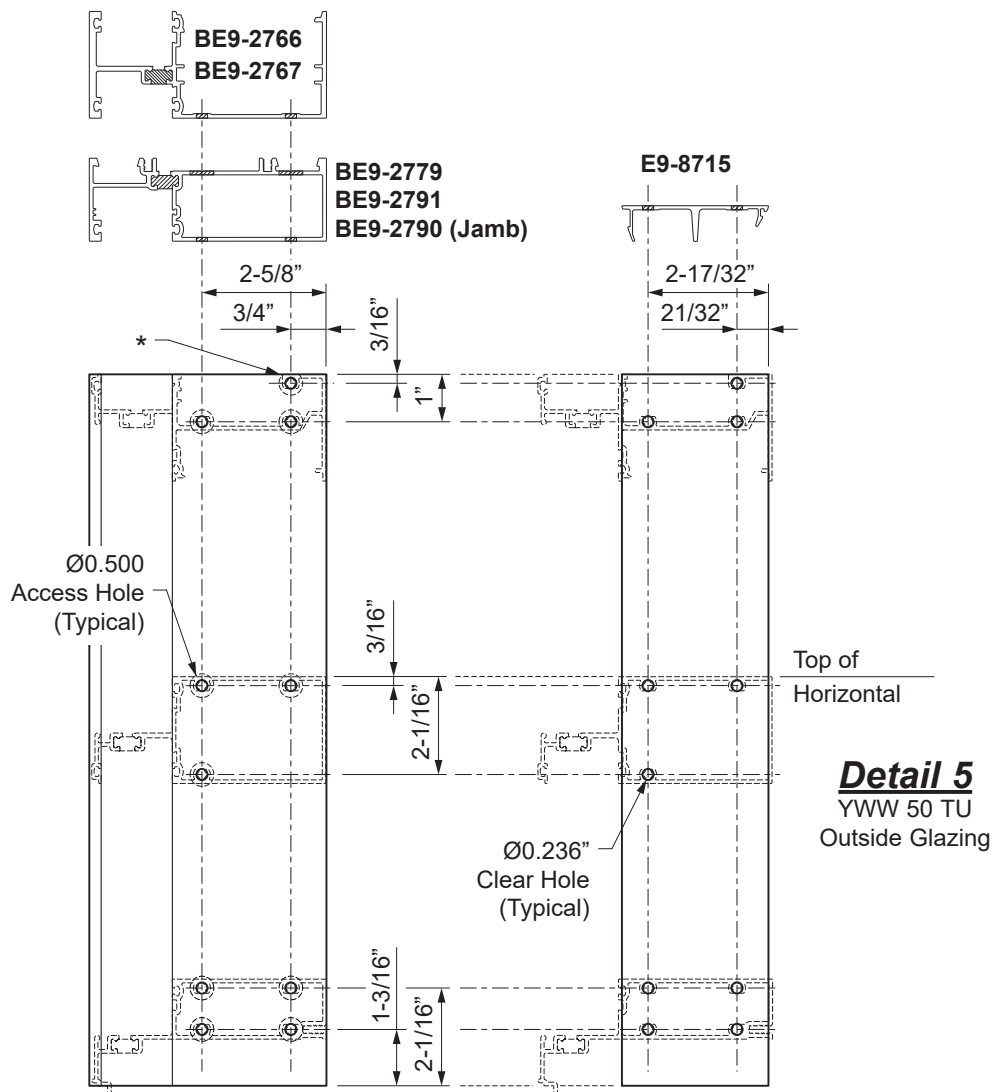

FRAME FABRICATION

**STEP 2 (Continued)
FABRICATE VERTICAL MEMBERS**

- Cut all jamb and two piece vertical members to the frame height determined in **Step 1**.
- Fabricate holes in the vertical members for screw spline attachment using one of the methods below:
 - Using the H-7264 drill fixture as a template, line up the glazing pockets and mark hole locations through the screw splines of the templates.
- OR**
- Layout hole locations on vertical members as shown in **Detail 6**.
- Drill 0.236" diameter (#B drill bit) holes at each location marked.

Notes: Additional fabrication will be required for the inclusion of steel reinforcing. Drill fixture plate can be used.

* A 5/16" diameter access hole can be used at the very top to eliminate sharp edges.

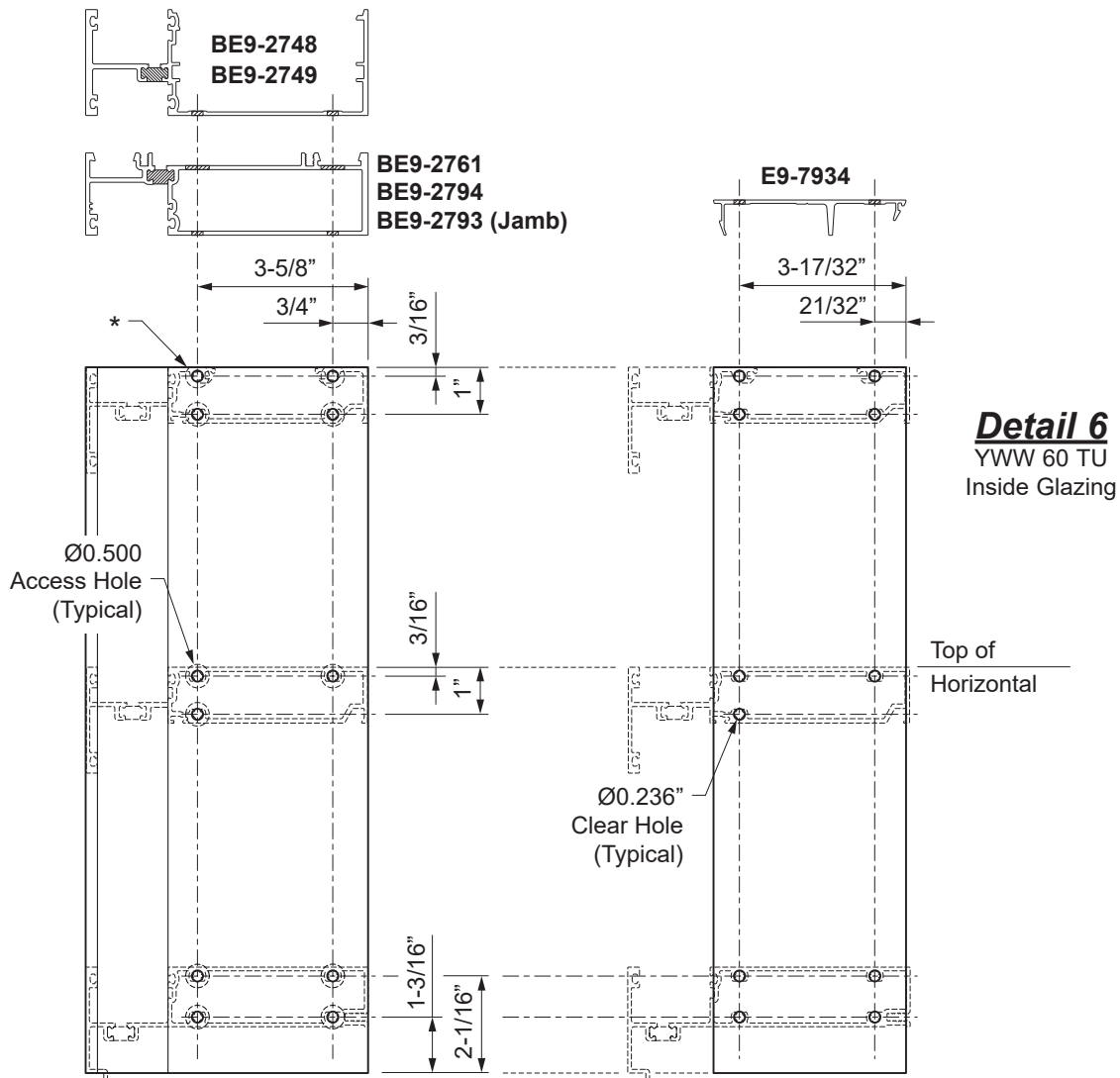

FRAME FABRICATION

STEP 2 (Continued)
FABRICATE VERTICAL MEMBERS

-For hollow vertical members, fabricate access holes in addition to the clear holes according to the methods previously shown and in **Detail 7**.

Notes: Additional fabrication will be required for the inclusion of steel reinforcing.

* A 5/16" diameter access hole can be used at the very top to eliminate sharp edges.

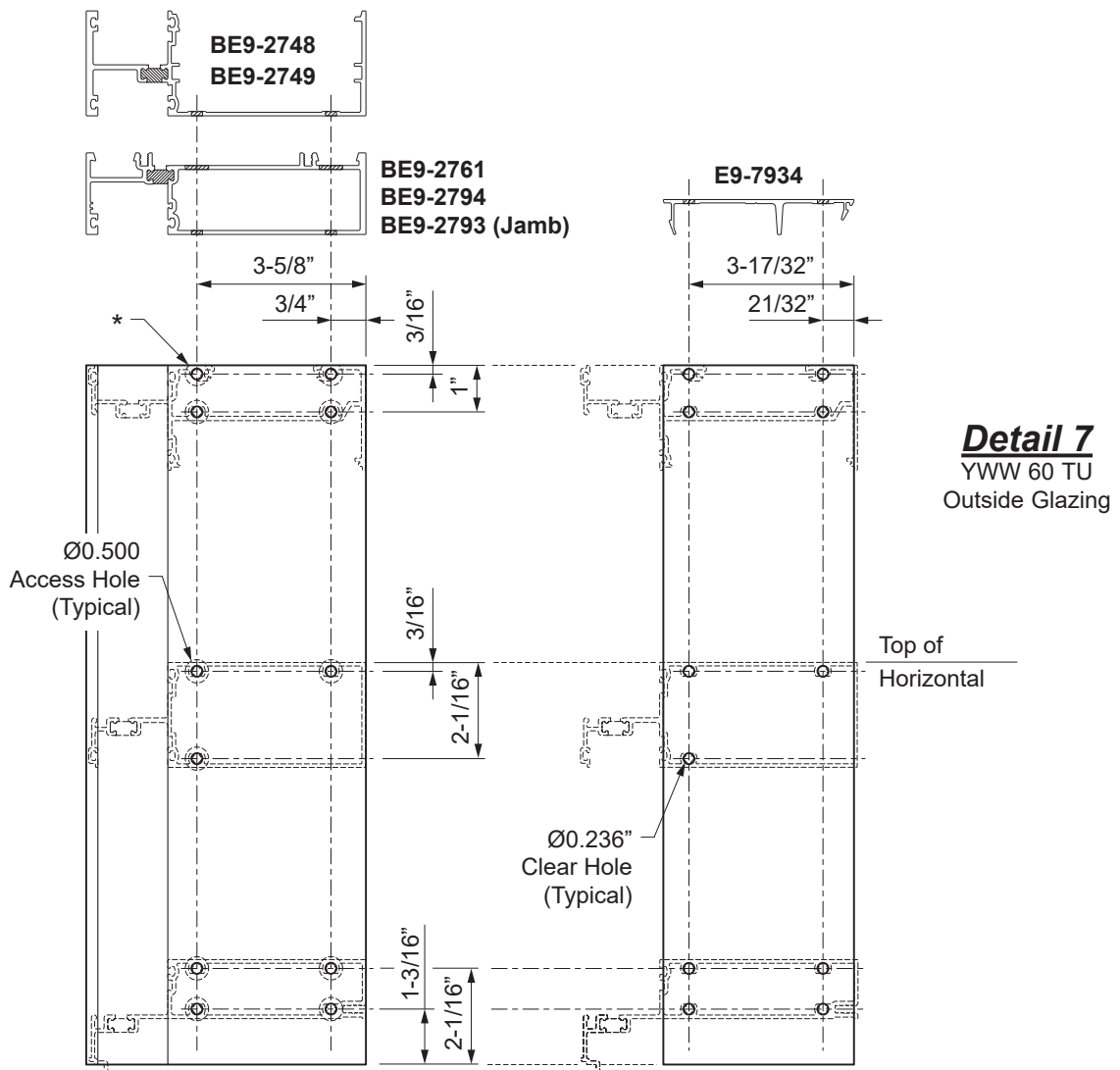

FRAME FABRICATION

**STEP 3
FABRICATE HORIZONTALS**

-Cut all head members, immediate horizontals, and sill members to the horizontal daylight opening.
See **Detail 8**.

-Sill members (both inside and outside glazed) will require 0.500" diameter drain holes, 2" from each end along the "V" Groove.

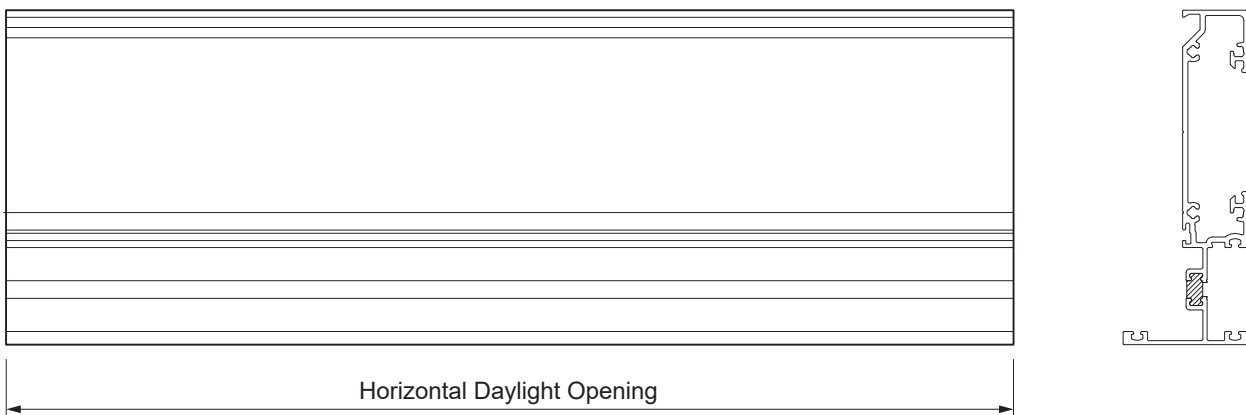

Detail 8

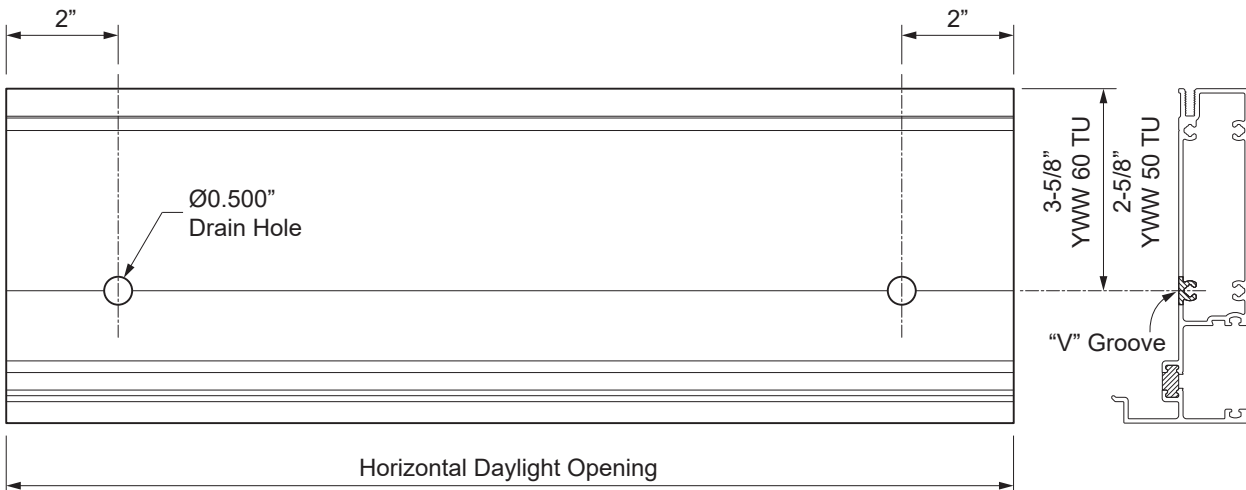

FRAME FABRICATION

STEP 3 (Continued)
FABRICATE HORIZONTALS

When the head is anchored to the substrate with the E1-1190 anchor, access holes will need to be drilled into the head member.

- Temporarily clamp the E1-1190 anchor onto the head where it will be in relation to the head member once anchored to the substrate.
- Drill 5/16" diameter holes into the head in line with the holes in the anchor. Unclamp the anchor. Then drill the access holes out to 3/4" diameter.

Notes: This is in addition to the 0.189" diameter tap holes for the glass stop. Refer to FPA drawings or shop drawings for appropriate fastener and hole locations as determined by a qualified engineer.

See **Detail 9**.

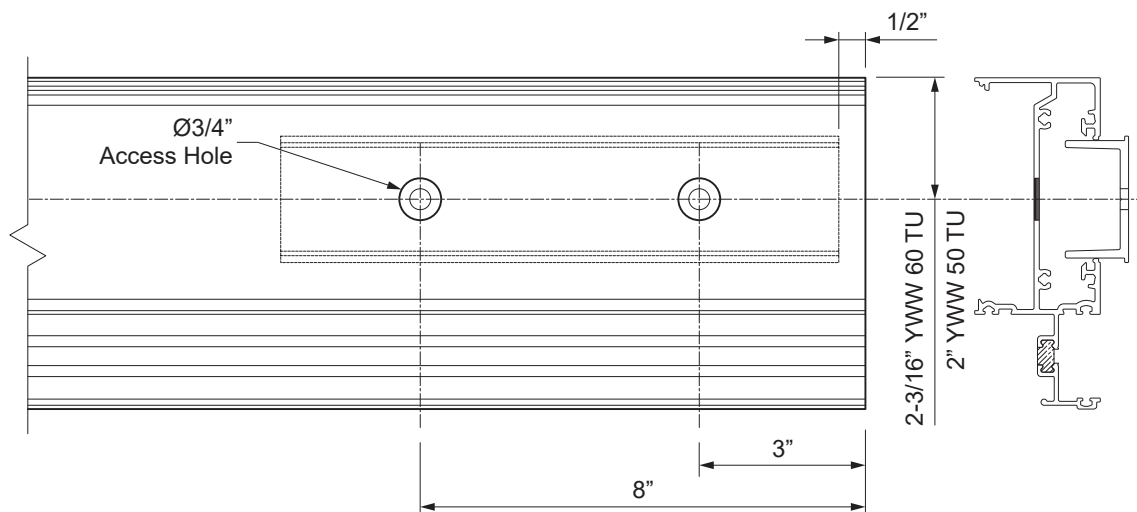

Detail 9

FRAME FABRICATION

**STEP 4
FABRICATE FILLERS & GLASS STOPS**

- Cut all vertical perimeter PVC flat fillers to the length of the jambs, except where strap anchors would interfere with the jamb filler.
- Cut all horizontal flush fillers, flat fillers, and interior covers to horizontal daylight opening minus(-) 1/32".

See **Detail 10**.

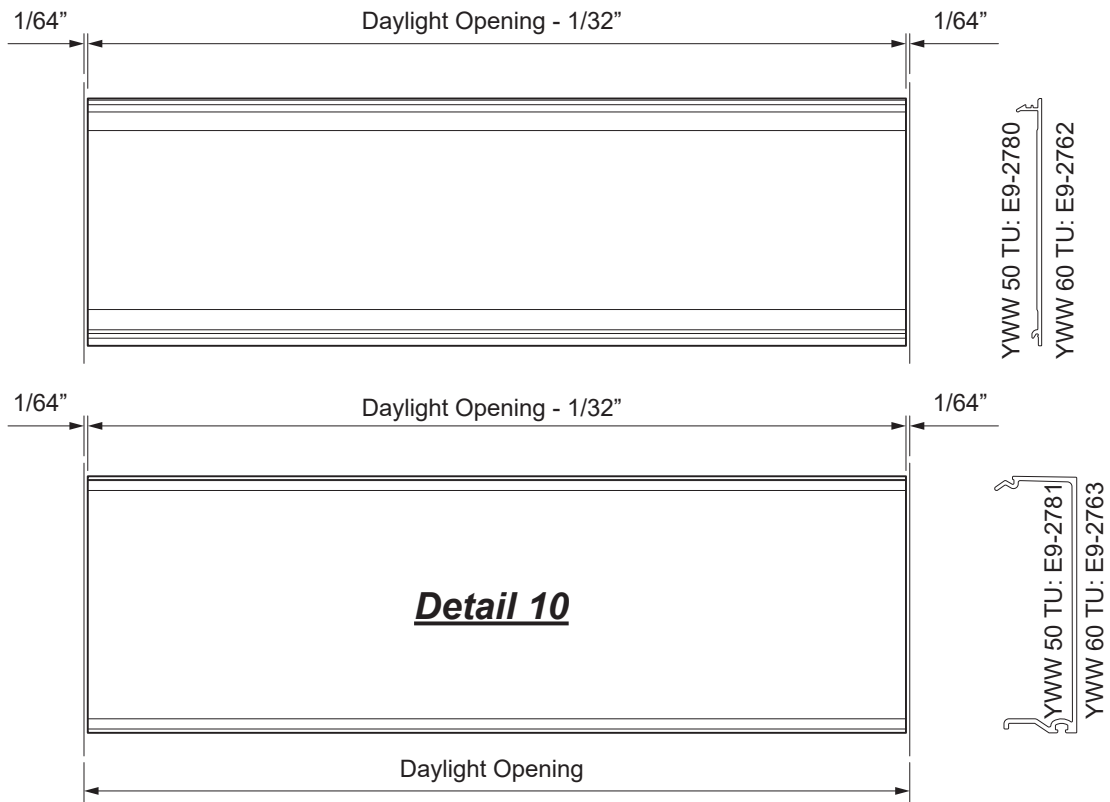

- Cut E9-1715 exterior glass stops to horizontal daylight opening minus(-) 1/16". See **Detail 10A**.

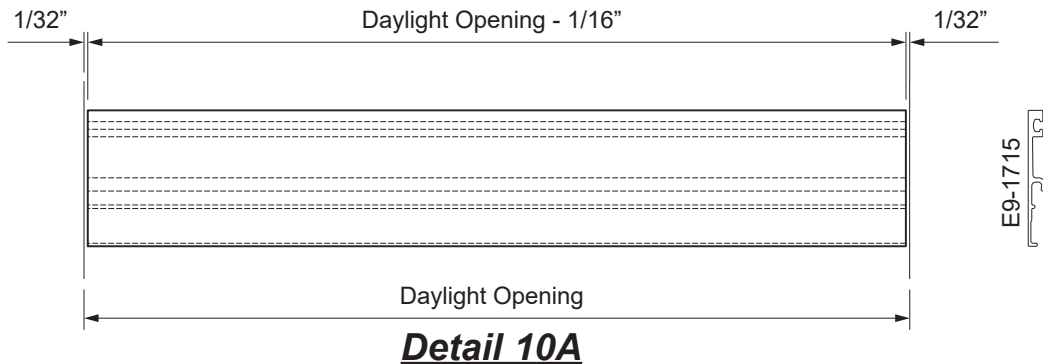

FRAME FABRICATION

STEP 5
FABRICATE SILL FLASHING

- Cut the sill flashing to the frame width plus(+) 5/16" at each jamb.
- For door jambs, allow the sill flashing extend beyond the YWW framing by 1/8".
- Cut the E9-2868 interior cover to the same dimension as the sill flashing.
- Note:** For additional possibilities such as slab edge cover application, it is recommended to provide additional space between the edge of the sill flashing and the jamb substrate.
- For frame openings longer than 24'-0", allow for a 3/8" splice joint between sill flashing members every twelve to fifteen feet at the center of a daylight opening.
- Mark the front face of the sill flashing at the center of each vertical location and the midpoint of the daylight opening between the verticals.
- Drill a Ø5/16" weep hole in the face of the sill flashing at each location marked.
- Also, drill a Ø0.213" clear hole in the back of the sill flashing at each location marked.

See **Detail 11**.

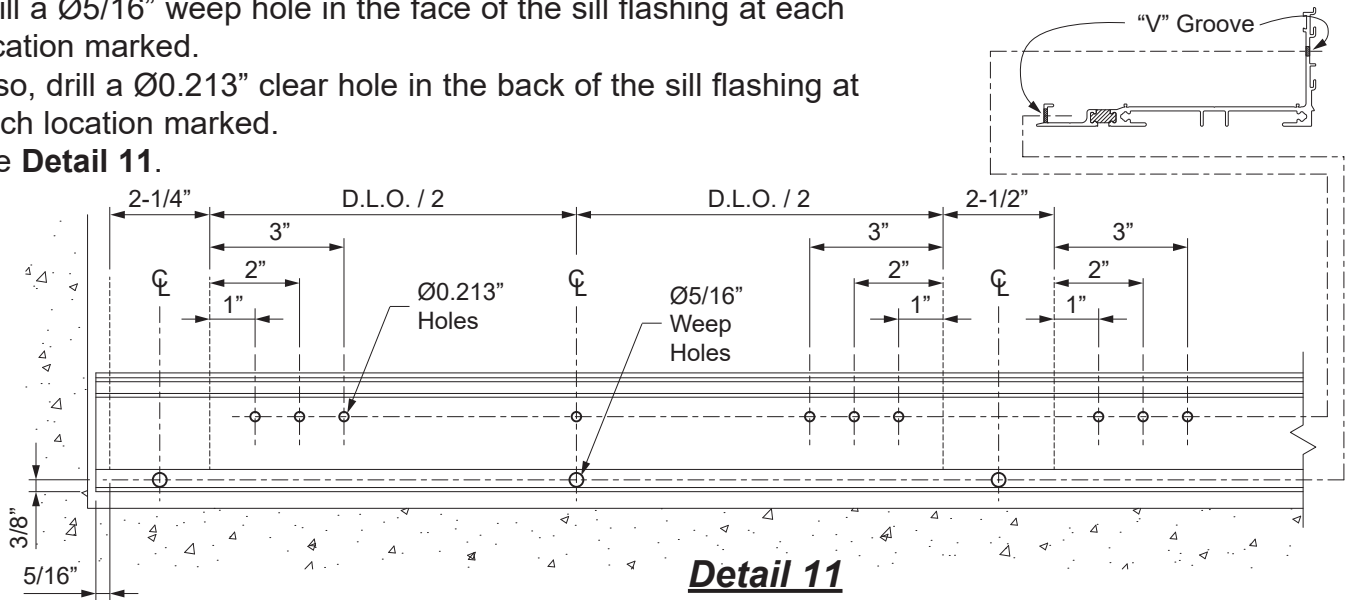

Additional fabrication will be required for BE9-2846 and BE9-2866 sill flashings used at slab edge covers if splices are needed.

- Notch the sill flashing as shown in **Detail 12**.

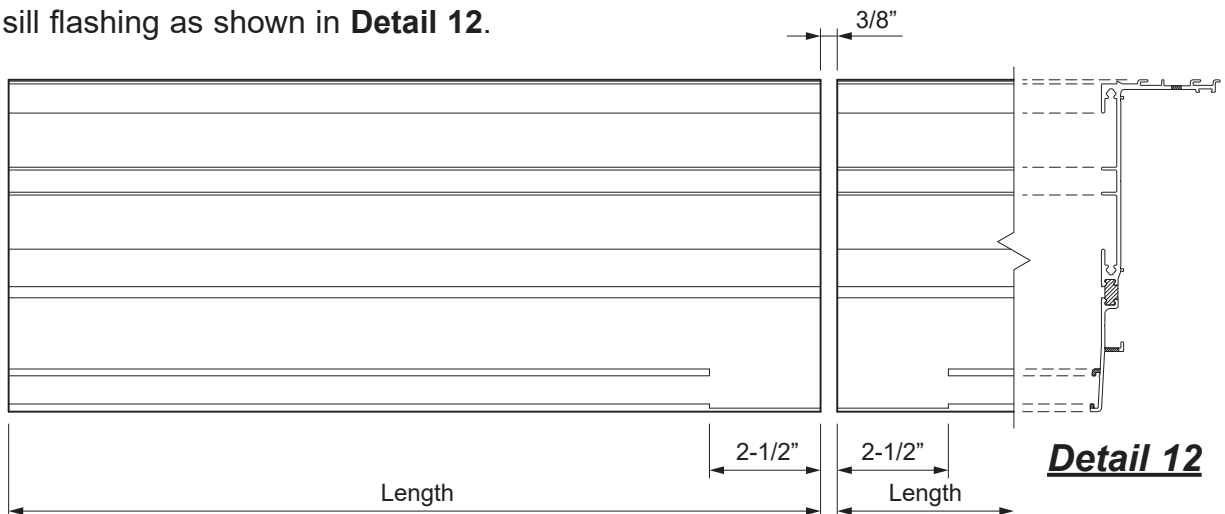

FRAME FABRICATION

**STEP 5A
FABRICATE SLAB EDGE PLATE ADAPTOR**

- Cut the aluminum plate adaptor E9-8222 to the same length as the sill flashing.
- Notch the aluminum plate adaptor 2-1/2" from each end at each splice joint location as shown in **Detail 13**.
- Cut slab edge cover plates to length as indicated on the approved shop drawings

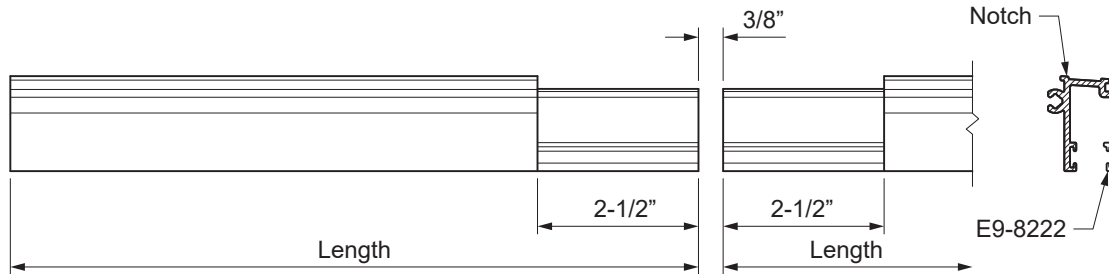

Detail 13

**STEP 6
FABRICATE CORNER COVERS**

- Cut the corner cover components to the mullion length. Drill 0.213" diameter holes into the cover at the v-groove where the cover will be fastened to the mullion at 3" from each end and at 24" maximum on center.

See **Detail 14**.

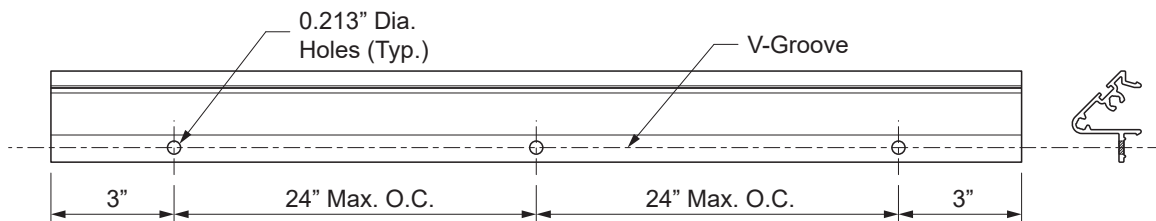

Detail 14

E9-2741 Shown,
Others Similar

FRAME FABRICATION

**STEP 7
FABRICATE HEAD RECEPTOR**

-Cut the head receptor to the frame width plus(+) 5/16” at each jamb.

Note: For additional possibilities such as slab edge cover application, it is recommended to provide additional space between the edge of the head receptor and the jamb substrate.

- For frame openings longer than 24’-0”, allow for a 3/8” splice joint between sill flashing members every twelve to fifteen feet at the center of a D.L.O.
- Mark the front face of the head receptor at the center of each vertical location and the midpoint of the daylight opening between the verticals.
- Drill 5/16” diameter weep holes in the head receptor at each location marked.
- Drill clear holes for anchor fasteners into the head receptor as indicated on the approved shop drawings and or P.E. calculations.

See **Detail 15**.

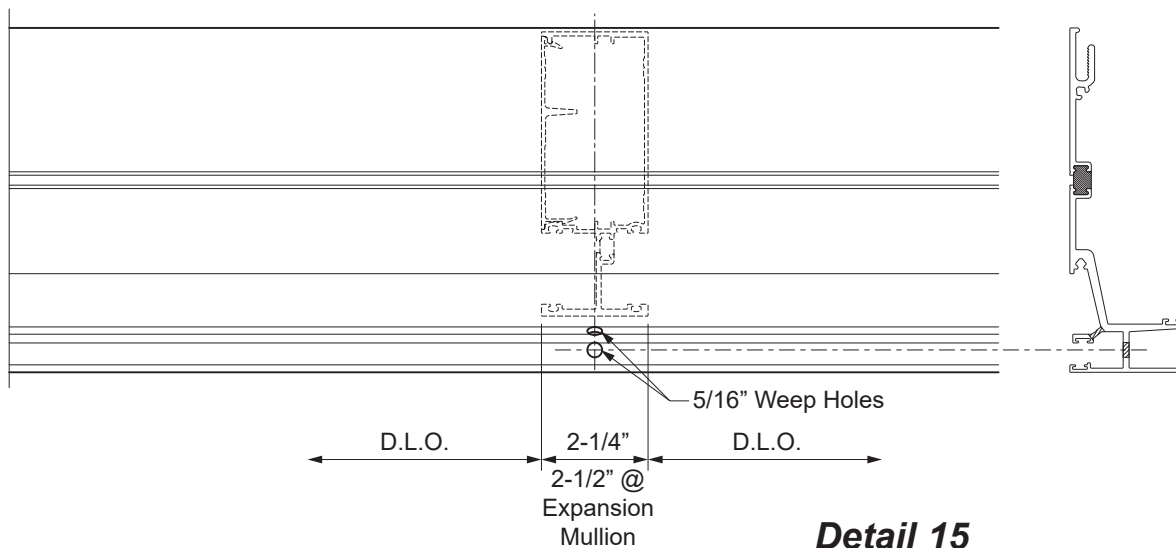

Detail 15
 Note: Anchor Hole Locations Shown for Reference Only

FRAME ASSEMBLY

**STEP 8 (Continued)
ASSEMBLE FRAME -- CORNER MULLION**

- Apply sealant to the interior snap interface of the interior corner cover, 6" up from the bottom of the mullion. Snap the cover pieces onto the corner mullion half. Fasten with PM-1006-SS fasteners at the holes previously drilled in fabrication.
- The exterior corner covers will require E2-0051 bulb gaskets cut to the length of the mullion. Apply dabs of sealant to the bottom of the bulb gasket to adhere it to the cover so that it will not slide out during unit installation. Do not overseal. Insert the gasket into the reglet at the cover.
- The 90° corner cover will also require an E2-0110 spacer tape adhered to the cover for one side of the corner. (The other corner half for the adjoining unit will not need this spacer tape.)

See **Detail 16** for YWW 50 TU and **Detail 16A** for YWW 60 TU.

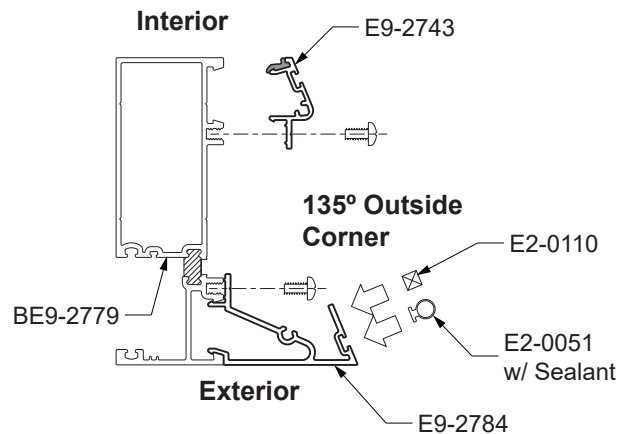
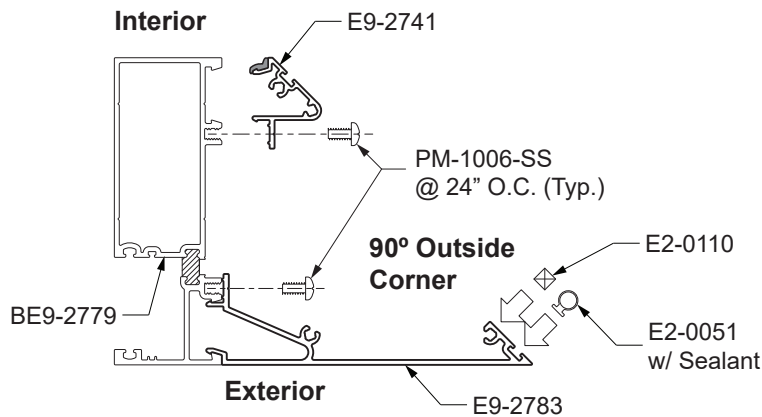

Detail 16
YWW 50 TU

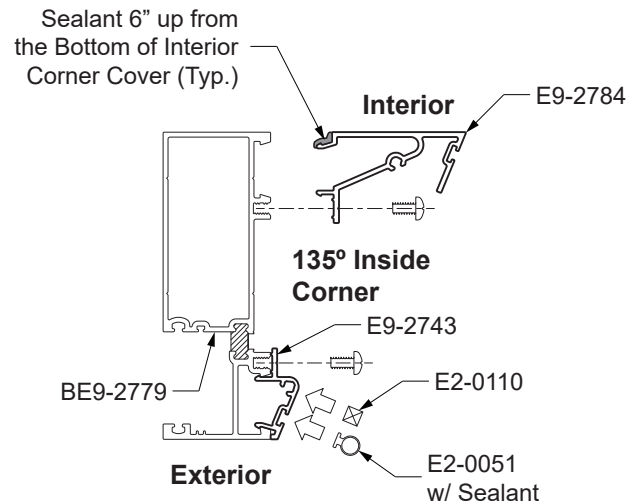
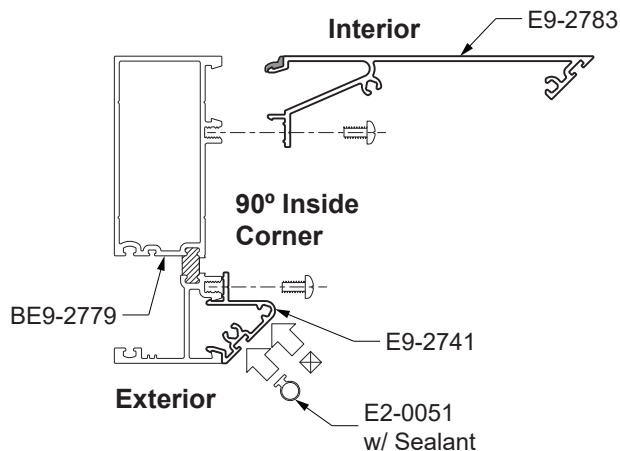

FRAME ASSEMBLY

STEP 8 (Continued)
ASSEMBLE FRAME -- CORNER MULLION

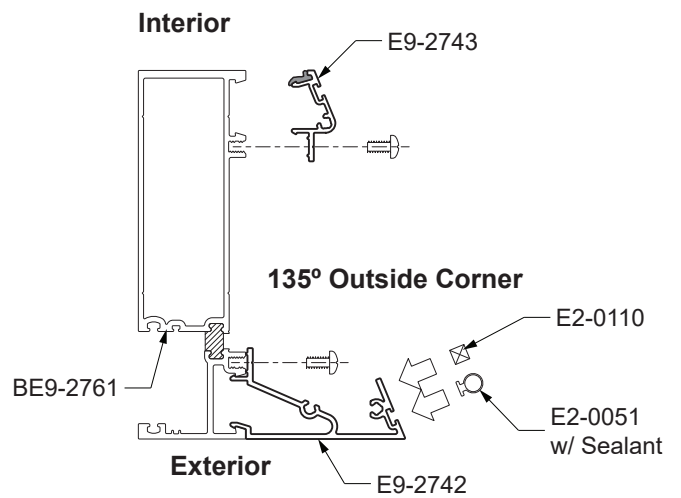
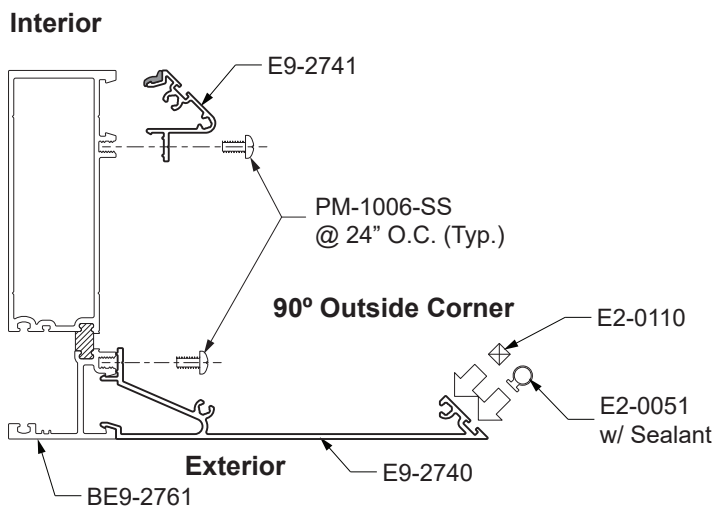

Detail 16A
YWW 60 TU

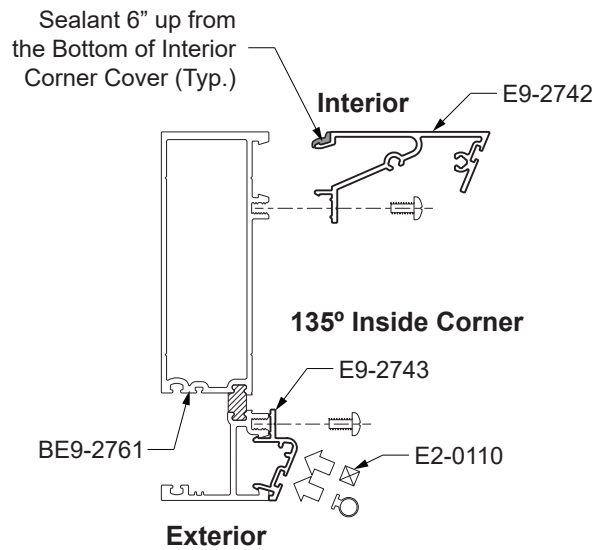
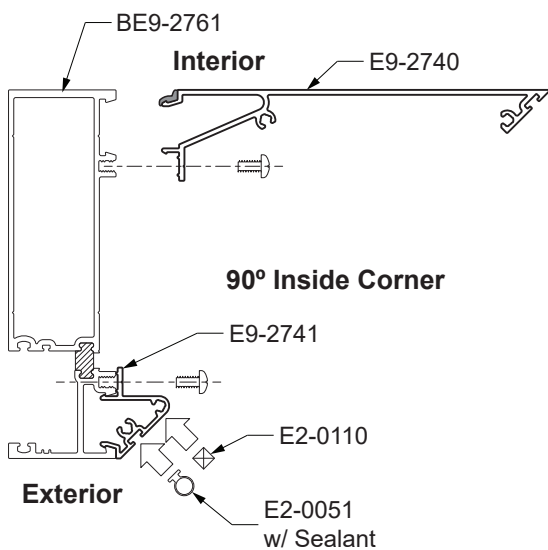

FRAME ASSEMBLY

**STEP 8 (Continued)
ASSEMBLE FRAME**

- If strap anchors are used at the head, insert them into the head member prior to assembly (2 per Daylight Opening, unless otherwise noted).
- Apply sealant to the end of the head, horizontals, and sill that is to be attached to the second mullion or jamb as previously shown in **Detail 17**.
- Attach the horizontal members to the mullion using PC-1220 screws.

See **Detail 18**.

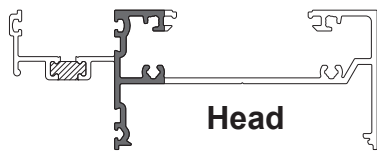

Head



**Intermediate
Horizontal**

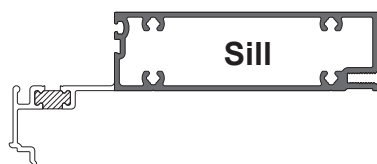

Sill

Detail 17

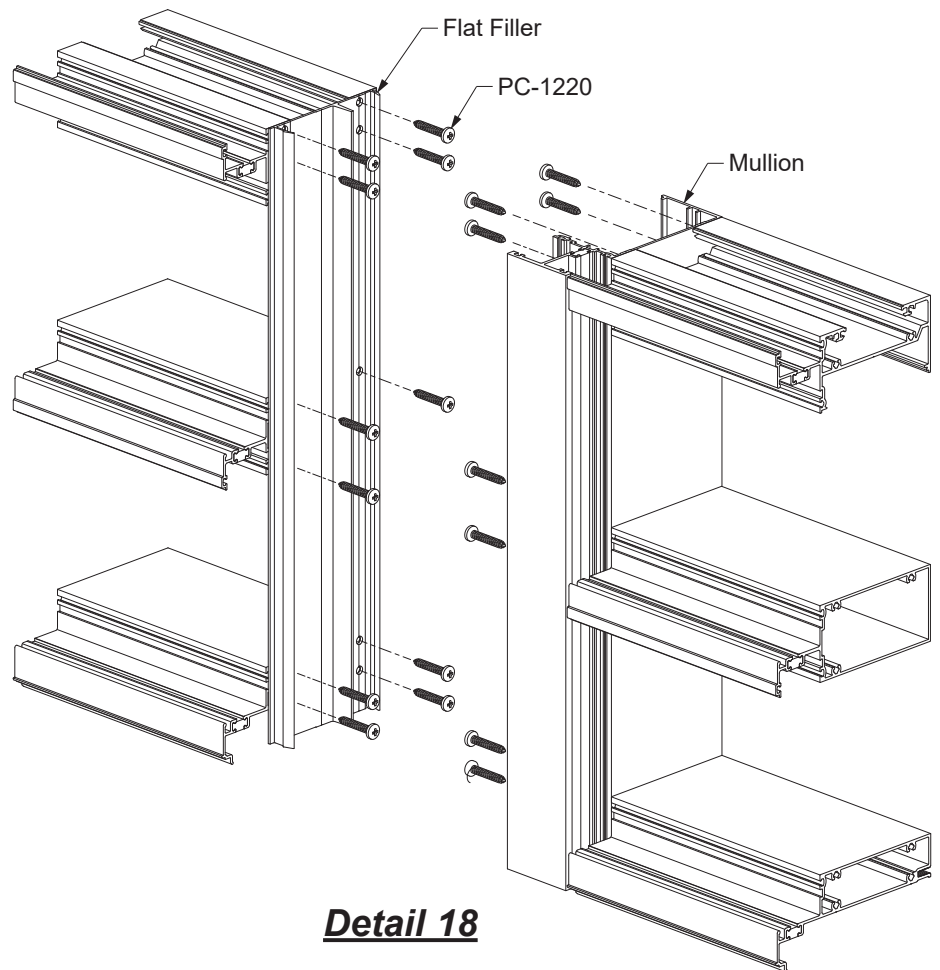

Detail 18

FRAME ASSEMBLY

STEP 9
INSTALL PERIMETER FILLERS

Install perimeter fillers into the jamb mullions and the head member.

-For the head, cut the E3-3664 pocket filler to horizontal daylight opening minus(-) 1/32" and snap it into the perimeter glazing pocket.

-If jamb strap anchors are used, install them into the jambs prior to installing perimeter fillers.
See **Detail 19**.

-At the jamb, cut the E3-3664 pocket filler to length of vertical and install it into the jamb.
-Cut the E2-0023 or E2-0032 to the length of the jamb, except where strap anchors would interfere.
Snap the filler into place.

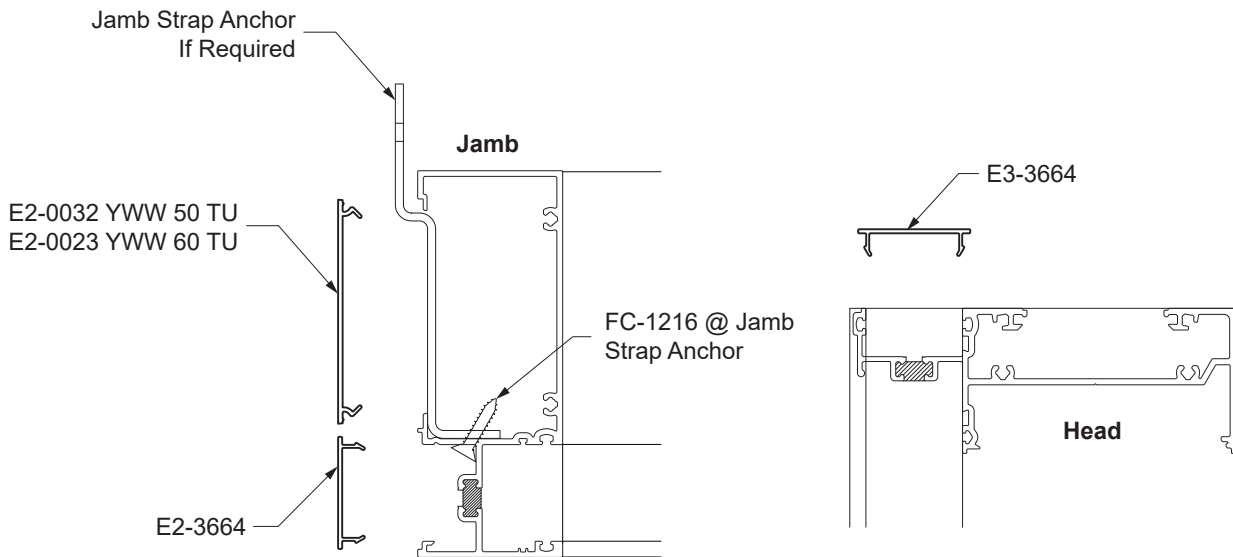

Detail 19

FRAME ASSEMBLY**STEP 10 (Not Necessary with Head Receptor)
INSTALL FOAM PLUGS AT HEAD**

- Cut E2-0259 foam backer tape (maximum 1-1/4" long) to be adhered at the head only. These will act as end caps for perimeter backer rods and sealant.
- Peel the adhesive tape from the foam and adhere it the mullion as shown in **Detail 20**. The foam can be easily compressed around physical obstacles in the assembled verticals.
- In the case where steel reinforcing is present at the head, the foam plugs may be adhered to the steel.
- Fill the cavities at the front of the verticals with sealant

Note: For best adhesion, make sure the contact surfaces of the verticals and or steel members are clean and dry.

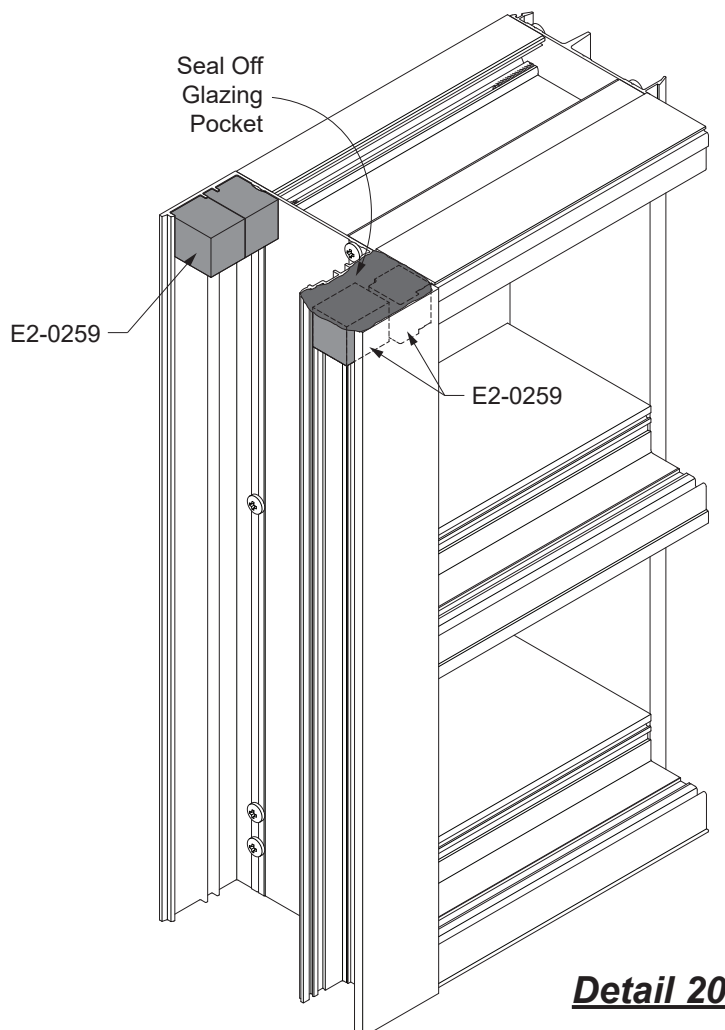

FRAME INSTALLATION

STEP 11 INSTALL SILL FLASHING END DAMS

-Bend the end dam tab left or right 90 degrees in order to “hand” the end dam for the left or right end of the flashing.

See **Detail 21**.

- Clean all joint surfaces using cleaner approved by sealant manufacturer.
- Apply sealant to the end of the sill flashing as shown in **Detail 22**.
- Slide the tab into the top portion of the sill flashing.
- Tap the tab into place with a small tool until the end dam is snug against the end of the flashing.
- Fasten the end dam to the sill flashing with three UA-1212 screws, starting at the back, followed by the front as shown in **Detail 22**.
- Tool sealant along the joint between the end dam and the sill flashing as shown in **Detail 23**.

E1-2851 for YWW 50 TU
E1-2852 for YWW 60 TU

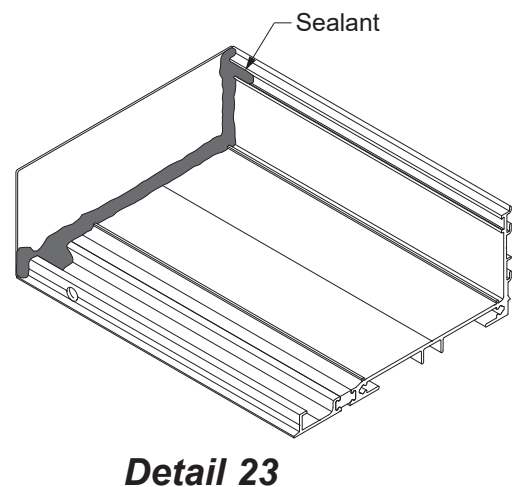
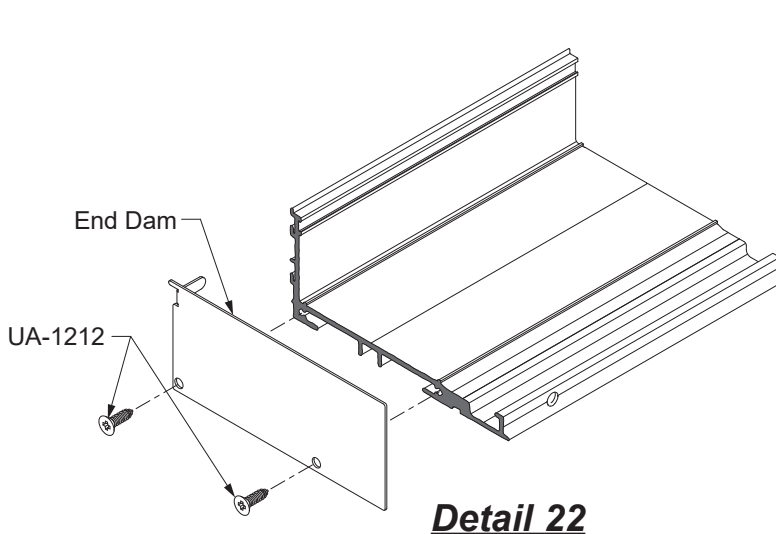
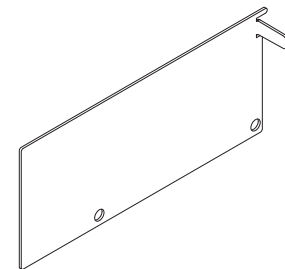
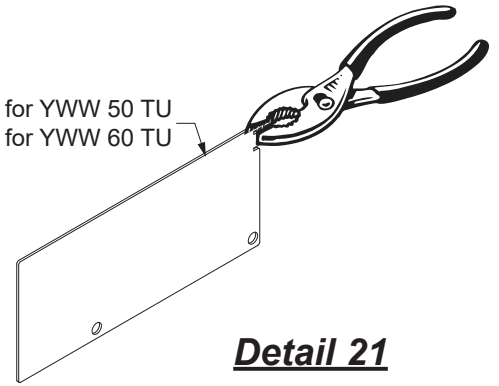

FRAME INSTALLATION

**STEP 11A
INSTALL SILL FLASHING END DAMS FOR SLAB
EDGE COVER**

- Sill flashings with slab edge covers will require an aluminum plate adaptor E9-8222 to be attached prior to field installation.
- Insert (2) E2-0065 weathering gaskets cut to the length of the reglets on the adaptor.
- Slide the slab edge adaptor onto the sill flashing.

See **Detail 24**.

- Installation of the E1-1196 end dam is the same as illustrated in the previous page, except that the end of the installed slab edge adaptor will also require sealant.
- Fasten an E1-1196 end cap onto the slab edge assembly using an additional UA-1212 screw.

See **Detail 25**.

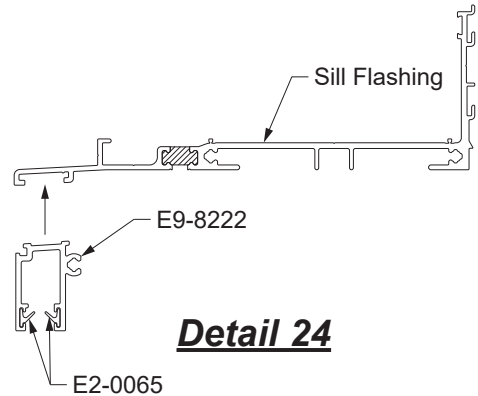

Detail 24

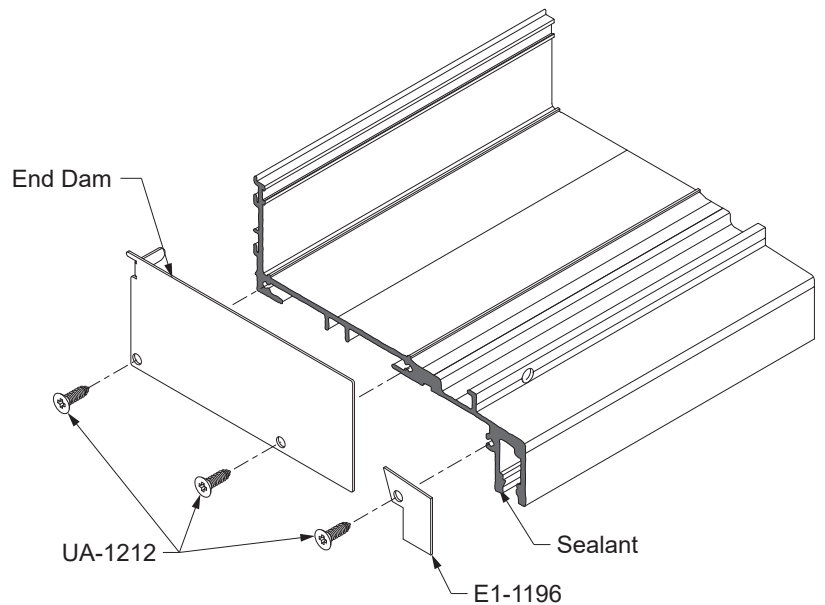

Detail 25

FRAME INSTALLATION

STEP 12

INSTALL BE9-2845/BE92846 (YWW 50 TU) OR BE9-2865/BE9-2866 (YWW 60 TU) SILL FLASHING

- Prior to installing the sill flashing, slide in E1-2853/E1-2854 strap anchors (2 per DLO) if they are being used.
- Install the sill flashing with a minimum of 3/8" shim space underneath. Sill flashing must be installed level.
- Anchor the sill flashing to the structure a maximum of 4" from each end and then 18" to 24" on center, per P.E. calculations, or per FPA drawings.
- Apply and tool sealant to cover the heads of all anchors and screws.

STEP 13

INSTALL SILL FLASHING SPLICE SLEEVE

- Remove the nub with a chisel or pliers on both sides of the splice joint 1-1/2" as shown in **Detail 26**.
- After the sill flashing has been shimmed and anchored to the building structure, insert a small backer rod under the sill flashing as shown in **Detail 27**.
- Position the Silicone Splice Sleeve against the back wall below the groove.
- Bend the Silicone Splice Sleeve into the front on the channel as shown. Mark and cut the sleeve at this position.
- Clean Sill Flashing and Silicone Splice Sleeve with isopropyl alcohol at the splice location.
- Seal the flashing at the splice location as shown in **Detail 27**, before positioning the flashing. Set the Silicone Splice Sleeve into the sealant.
- Tool sealant tight as shown in **Detail 27**, squeezing the sheet flat with a seam roller.

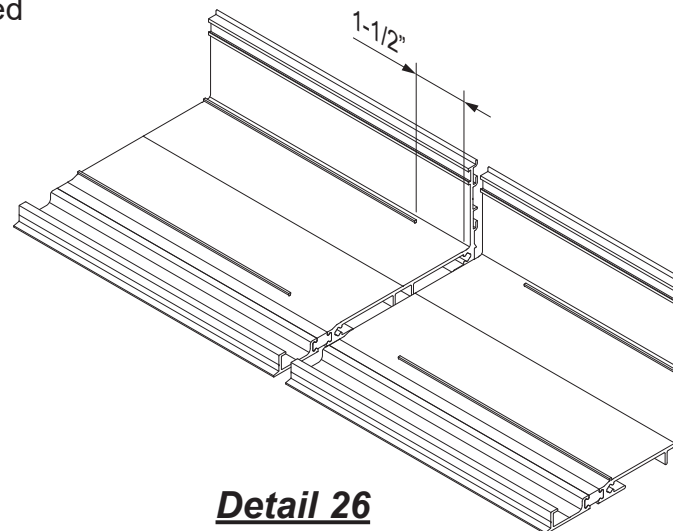
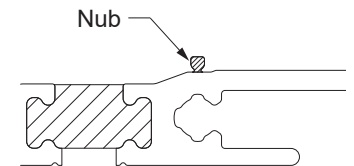

Detail 26

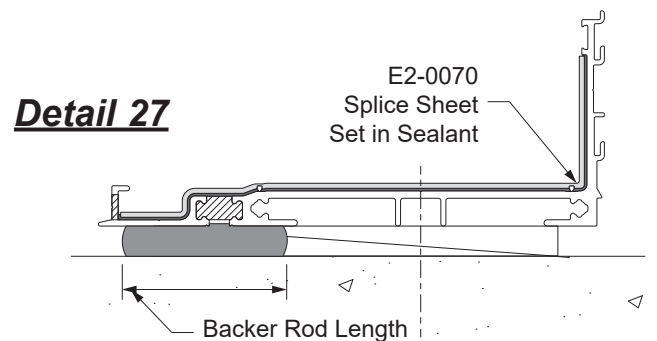
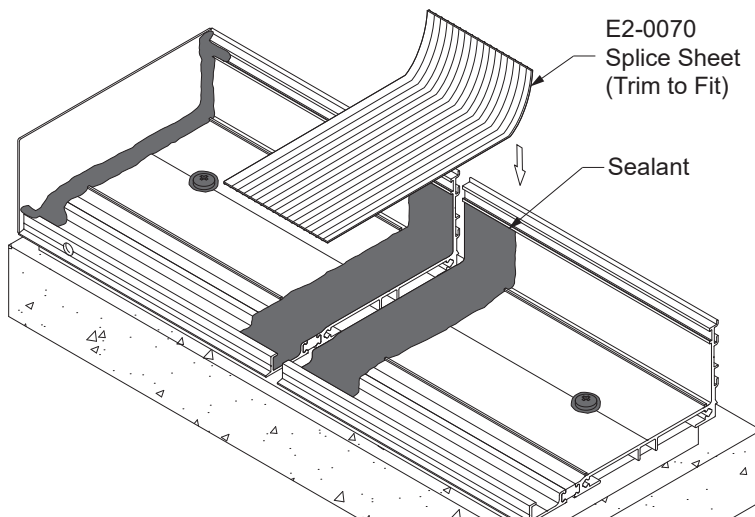

Detail 27

FRAME INSTALLATION**STEP 13 (Continued)
INSTALL SILL FLASHING SPLICE SLEEVE**

-Thoroughly seal the small joint directly in front of the Silicone Splice Sleeve as shown in **Detail 28**.

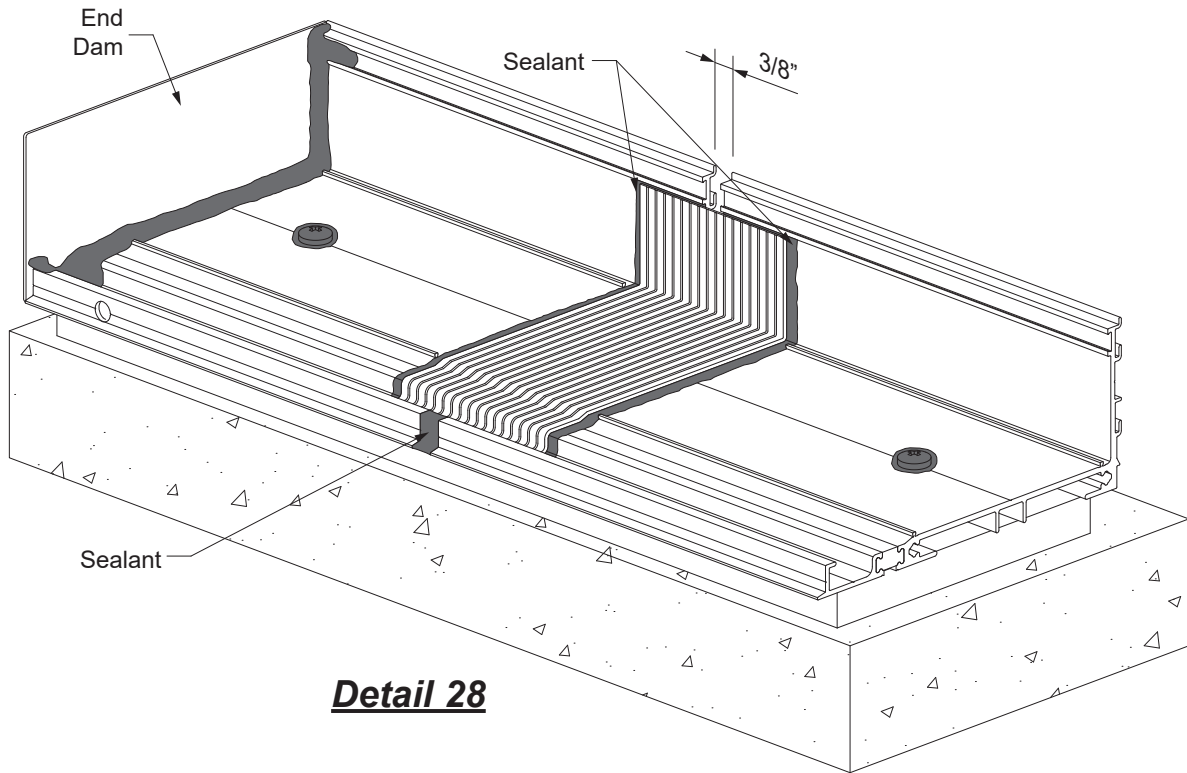

FRAME INSTALLATION

**STEP 14
SLAB EDGE COVER INSTALLATION**

Slab edge covers are installed from the head of the lowest elevation on upward. The head receptors are installed first, then slab edge plates, then the BE9-2846/BE9-2866 sill flashings with the E9-8222 slab edge adaptors.

**STEP 14A
INSTALL HEAD RECEPTOR END DAMS & WEATHERING GASKETS**

- Clean all joint surfaces using cleaner approved by sealant manufacturer.
- Apply sealant to the end of the head receptor as shown in **Detail 29**.
- Fasten the end dam to the head receptor with two UA-1212 screws, starting at the back, followed by the front.
- Tool sealant along the joint between the end dam and the head receptor as shown in **Detail 29**.
- Tape down the top corners to hold the end cap in place until the sealant cures.

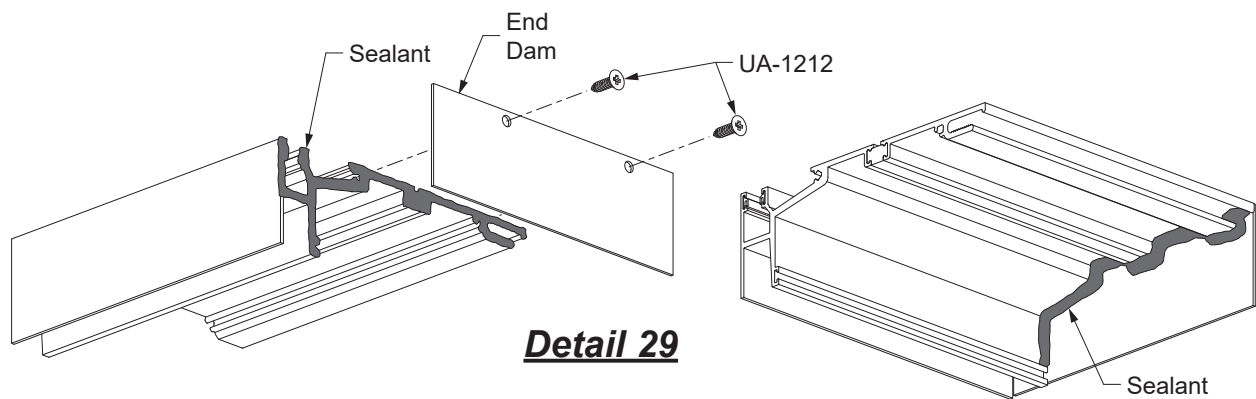

- Cut the E2-0051 airtight gasket to head receptor length plus 3/16” at each end for the splice joint, and insert it into its reglet for both the receptor and snap cover as shown in **Details 30 & 30A**.
- Cut the E2-0065 slab edge weathering gaskets to head receptor length. Insert the gaskets into the slab edge reglets in the orientation as shown in **Details 30A**.

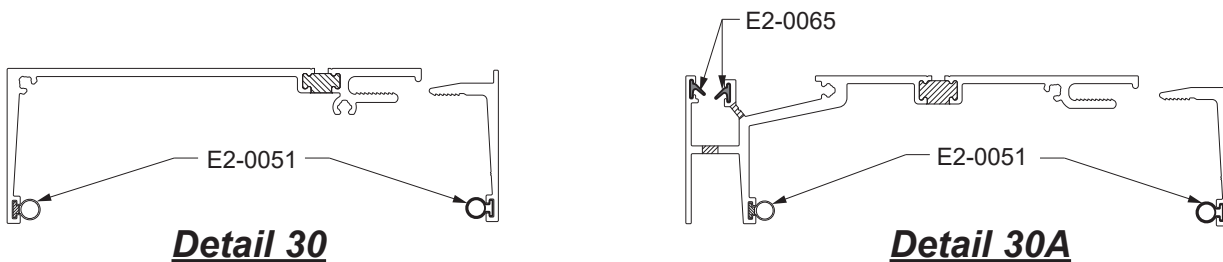

FRAME INSTALLATION**STEP 14B
INSTALL HEAD RECEPTOR**

- Starting at the smallest opening height, install the head receptor with the appropriate shim space (1/2" minimum) to ensure the dimensions from the approved shop drawings. Head receptor must be installed level.
- Anchor the head receptor to the structure according to approved shop drawings and or P.E. calculations.
- Apply and tool sealant to the heads of all fasteners.

See **Detail 31**.

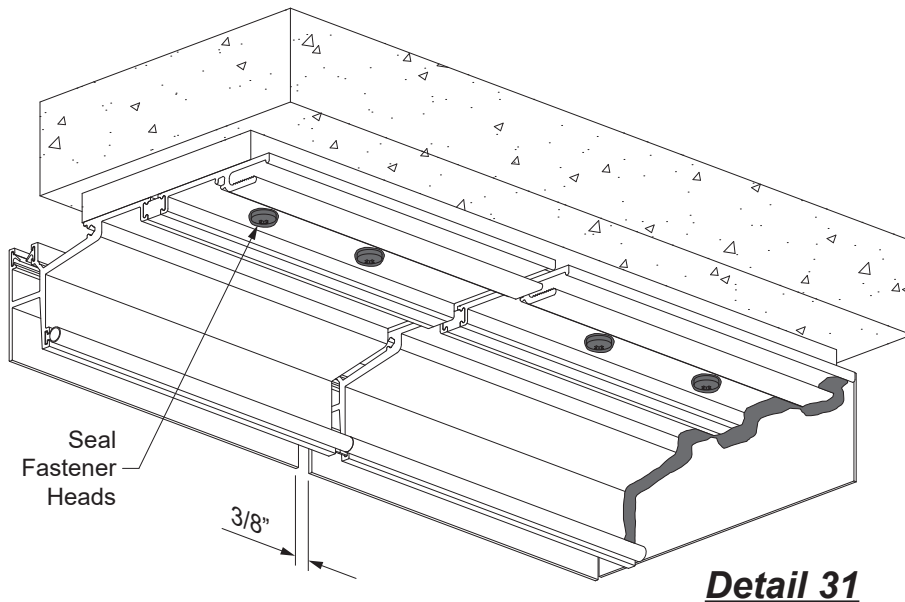

FRAME INSTALLATION

STEP 14B (Continued)
INSTALL HEAD RECEPTOR

-Prior to installing the Splice Sleeve, clean head receptor and Splice Sleeve with isopropyl alcohol at the splice location.

-Refer to the splice chart at the right for proper splice selection per head receptor used.

System	Head Receptor	Splice
YWW 50 TU	BE9-7635	E2-0070
YWW 50 TU	BY7-8426	E2-0070
YWW 50 TU	BE9-2819	E1-2813
YWW 60 TU	BE9-7736	E2-0070
YWW 60 TU	BE9-7299	E1-9824

- Position the Splice Sleeve against the front wall inside the head receptor, set in sealant centered on the splice joint as shown in **Detail 32**. For E2-0070 sheet, trim as necessary to fit.
- Tool the sealant. For E2-0070 sheet, use a seam roller to press the sheet tight against the receptor.
- Seal the ends of the E2-0051 gasket together at the splice.

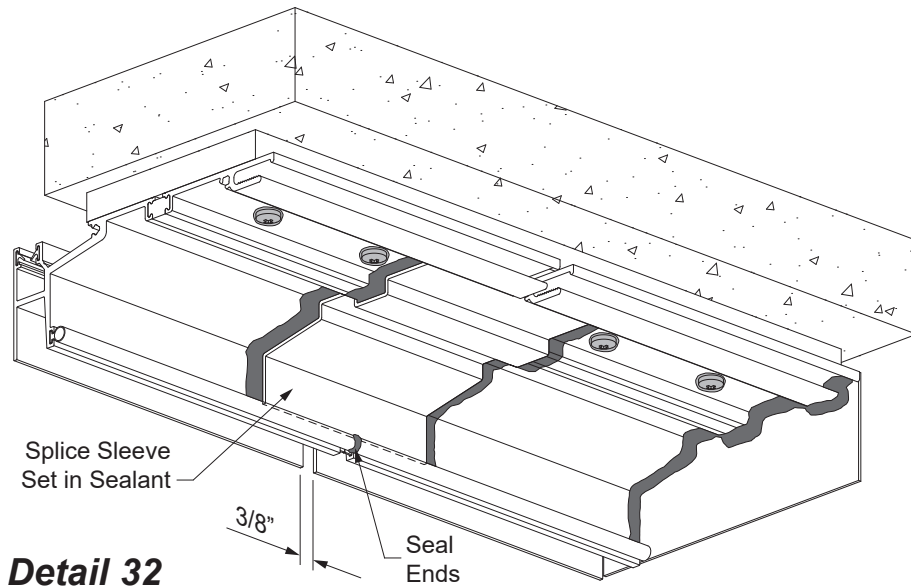

Detail 32

FRAME INSTALLATION**STEP 14B (Continued)
INSTALL HEAD RECEPTOR SPLICE SLEEVE**

-At the slab edge receptacle of the head receptor, position an E1-9961 splice sleeve centered on the splice joint. Set the splice sleeve in sealant, similar to the procedure previously outlined for the underside of the head receptor.

See **Detail 33**.

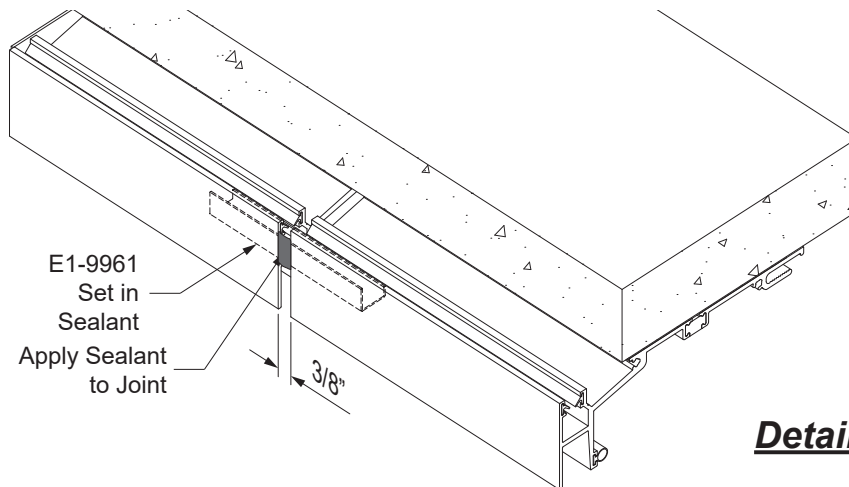
**Detail 33**

FRAME INSTALLATION

**STEP 14B (Continued)
INSTALL HEAD RECEPTOR GASKETS**

- Install E2-0054 setting blocks at 1/4 points of the aluminum plate.
- Install a weep baffle, E2-0099, over every weep hole location.
- Do not install the snap cover yet.

See **Detail 35**.

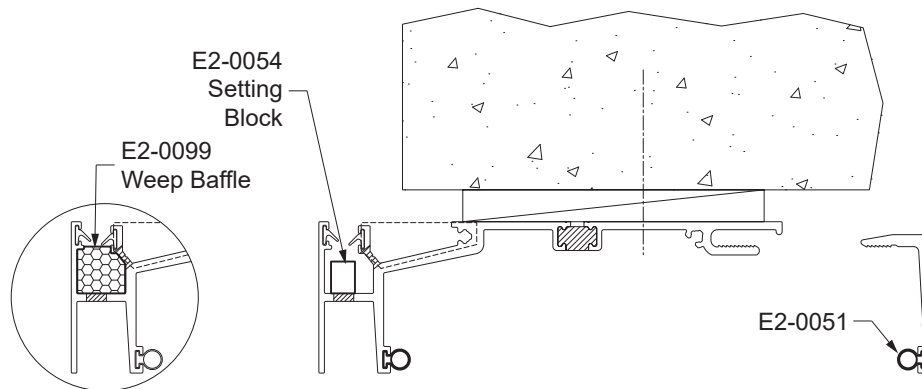

Detail 35

**STEP 14C
ASSEMBLE SLAB EDGE COVER PLATES**

- Clean the ends of the slab edge cover and attachment areas of end caps using a cleaner approved by sealant manufacturer.
- Apply and tool sealant to each end of the slab edge cover prior to attaching the end caps.
- Attach end caps to each end of the slab edge cover using (2) UA-1212 fasteners.
- Tool and wipe away any excess sealant at the joints.

See **Detail 36**.

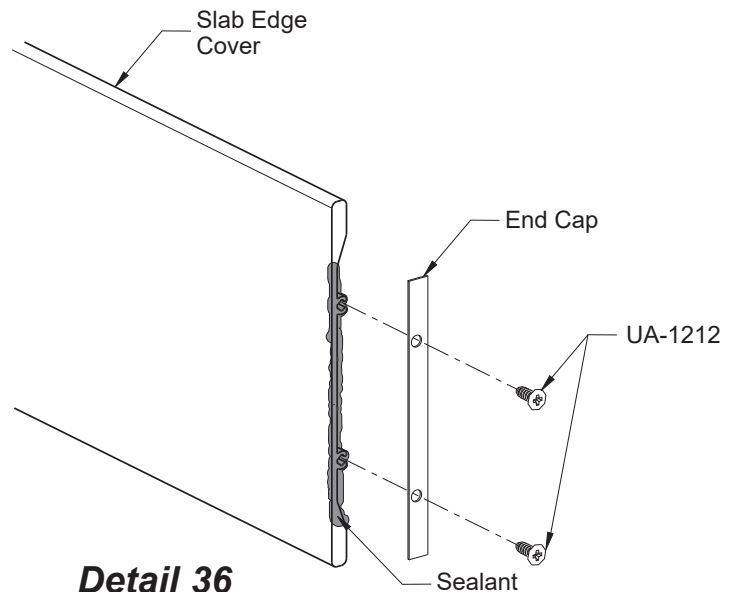

Detail 36

FRAME INSTALLATION

**STEP 14D
INSTALL SLAB EDGE COVER FASCIA**

- Slide the slab edge cover plate into the head receptor receptacle, seating it on top of the setting blocks.
- Be sure to leave a 3/8" joint between the plates for runs longer than 24'-0".

See **Detail 37**.

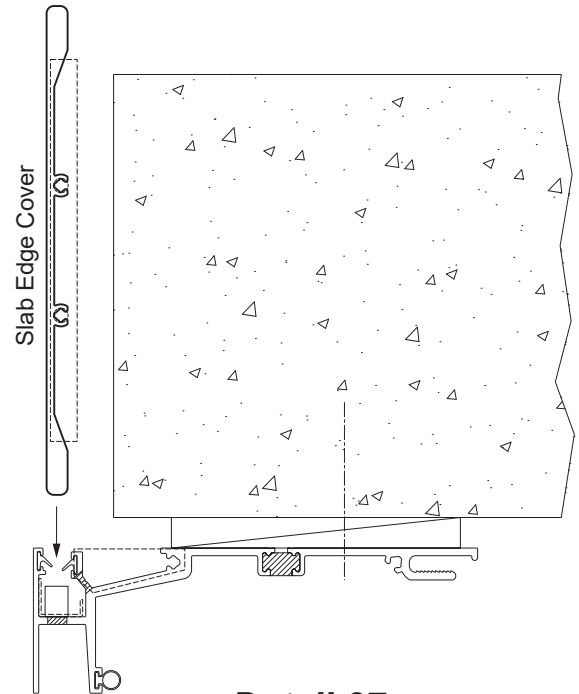

Detail 37

**STEP 14E
INSTALL SILL FLASHING SPLICE SLEEVE FOR
SLAB EDGE COVER**

Before installing the sill flashing, install an E1-2855 splice sleeve at the underside of the sill flashing and slab edge adaptor.

- Apply bond breaker tape down the middle of the splice sleeve and sealant to one side of the splice sleeve as shown in **Detail 38**.
- Adhere the sealed half of the splice sleeve to the underside of the sill flashing.

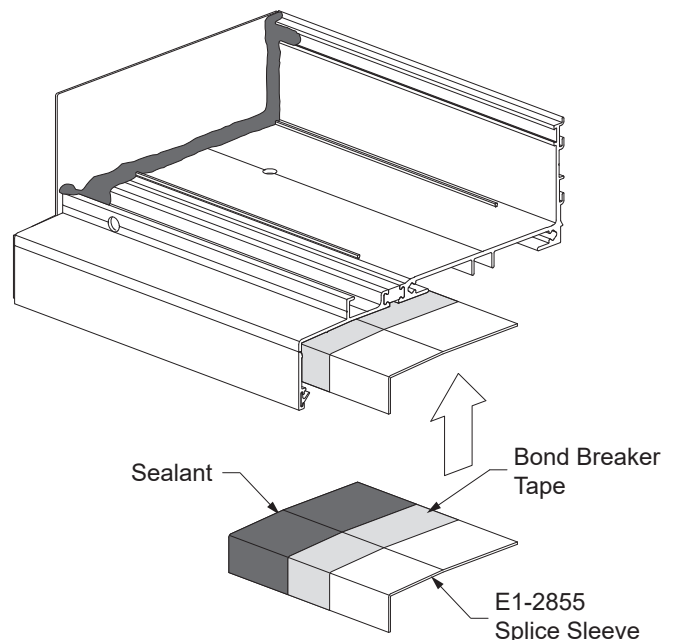

Detail 38

FRAME INSTALLATION

STEP 14E (Continued)

INSTALL SILL FLASHING SPLICE SLEEVE AT SLAB EDGE

- Install the sill flashing assembly onto the substrate, with 1/2" minimum shim space, engaging the slab edge cover plates below and sealing all anchor fastener heads.
- Install the next slab edge sill flashing assembly onto the splice sleeve as shown in **Detail 39**. Be sure to leave a 3/8" splice joint between the sill flashing assemblies.

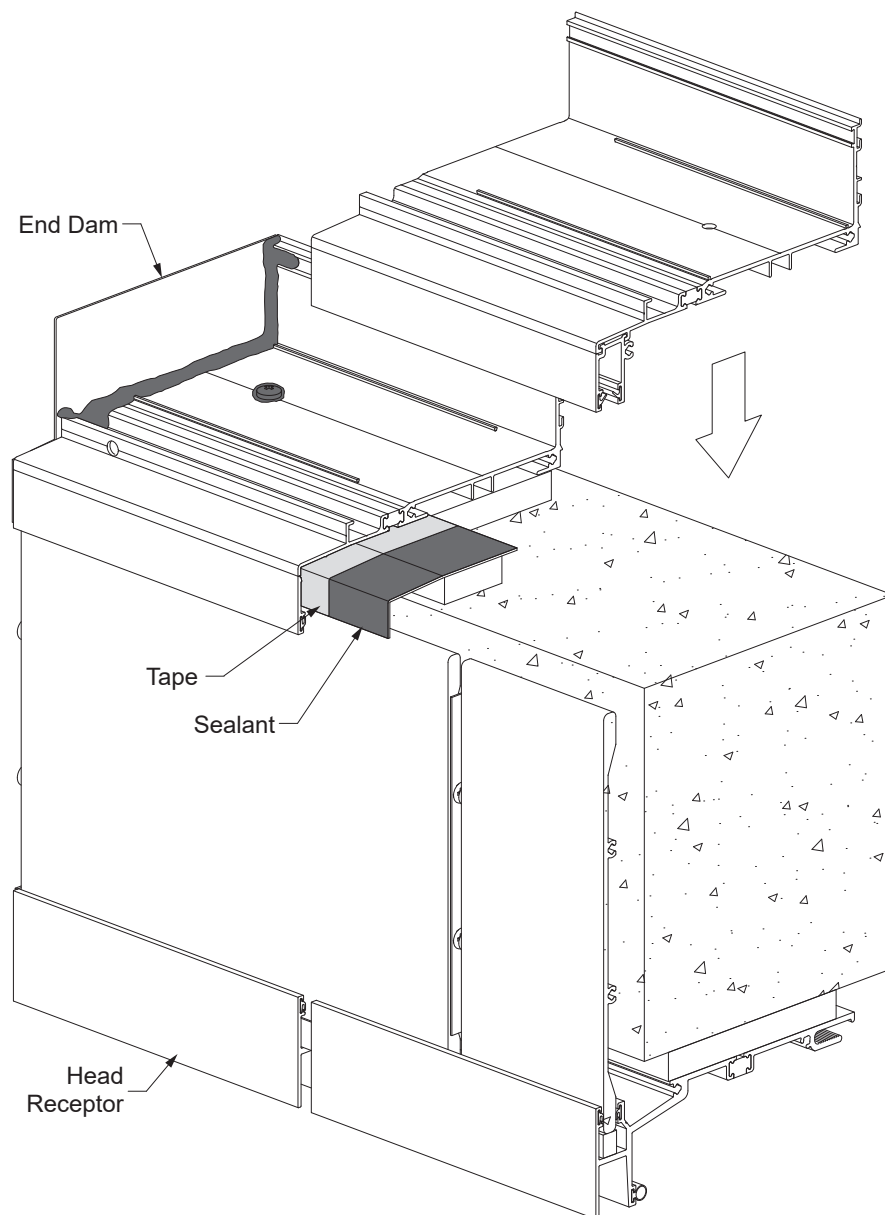

Detail 39

FRAME INSTALLATION**STEP 14E (Continued)****INSTALL SILL FLASHING SPLICE SLEEVE AT SLAB EDGE**

-Installation of the E2-0070 splice sleeve is the same as previously outlined in **Step 13**, except to apply sealant to the joint at the slab edge cover plate, adaptor, and head receptor as shown in **Detail 40**.

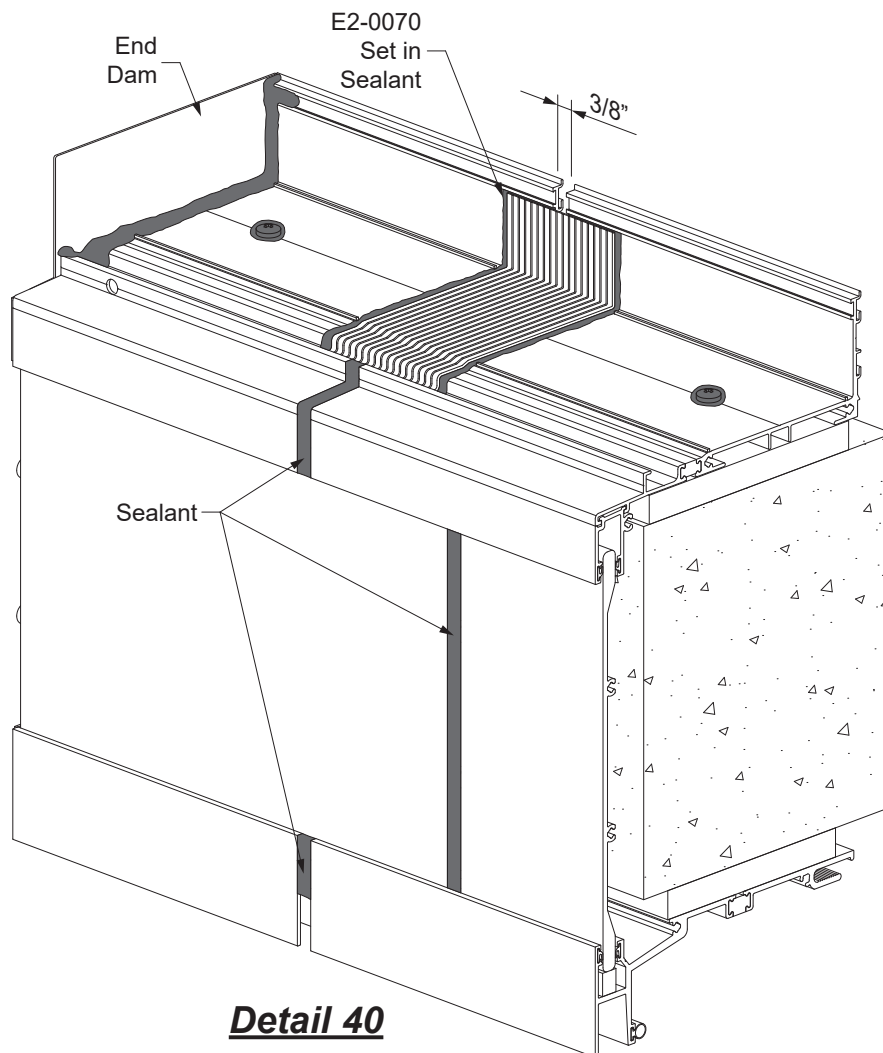

FRAME INSTALLATION

STEP 15

INSTALL BE9-2845 / BE9-2865 SILL FLASHING AT CORNERS

- Cut two 12" long pieces of sill flashing and miter(45° for 90° corners).
- Align the two pieces at the corner condition with the mitered ends pushed together tight and anchor the sill flashing as indicated on the approved shop drawings and or P.E. calculations.
- Apply and tool sealant to the mitered joint and anchor heads.

See **Detail 41**.

-Continue installing the rest of the sill flashing providing a 3/8" expansion joint at splices as shown in **Step 12 & 13 on Page 27 & 28**.

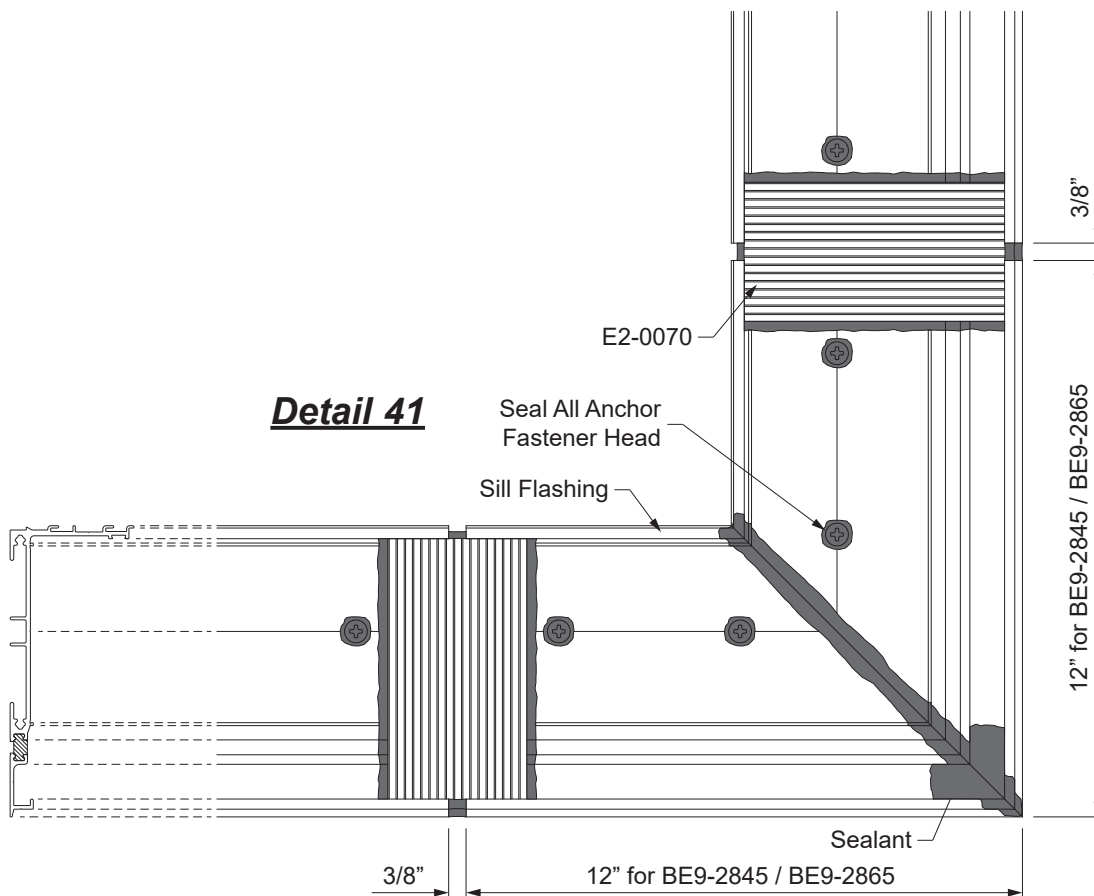

FRAME INSTALLATION

STEP 15A

INSTALL BE9-2846 / BE9-2866 SILL FLASHING AT CORNERS *

- Cut two 13-3/16" long pieces of sill flashing and E9-8222 slab edge cover adaptor, and miter (45° for 90° corners). The head receptor that is to be installed below will also receive the same miter cut fabrication.
- Install the head receptor using similar procedure as previously described for the sill flashing.
- Miter cut the slab edge cover plates 45° for 90° corners, such that upon installation, they leave a 1/2" gap at the corner.
- Fasten end caps onto the edge of the slab edge cover plates.
- Install the slab edge plates onto the setting blocks of the head receptor below.
- Align the two pieces of the sill flashing at the corner condition with the mitered ends pushed together tight and anchor the sill flashing as indicated on the approved shop drawings and or P.E. calculations.
- Apply and tool sealant to the mitered joint and anchor heads.

See **Detail 42**.

- Continue installing the rest of the sill flashing providing a 3/8" expansion joint at splices as shown in **Step 14 Pages 29 to 36**.

* **Note:** Similar technique required for head receptor.

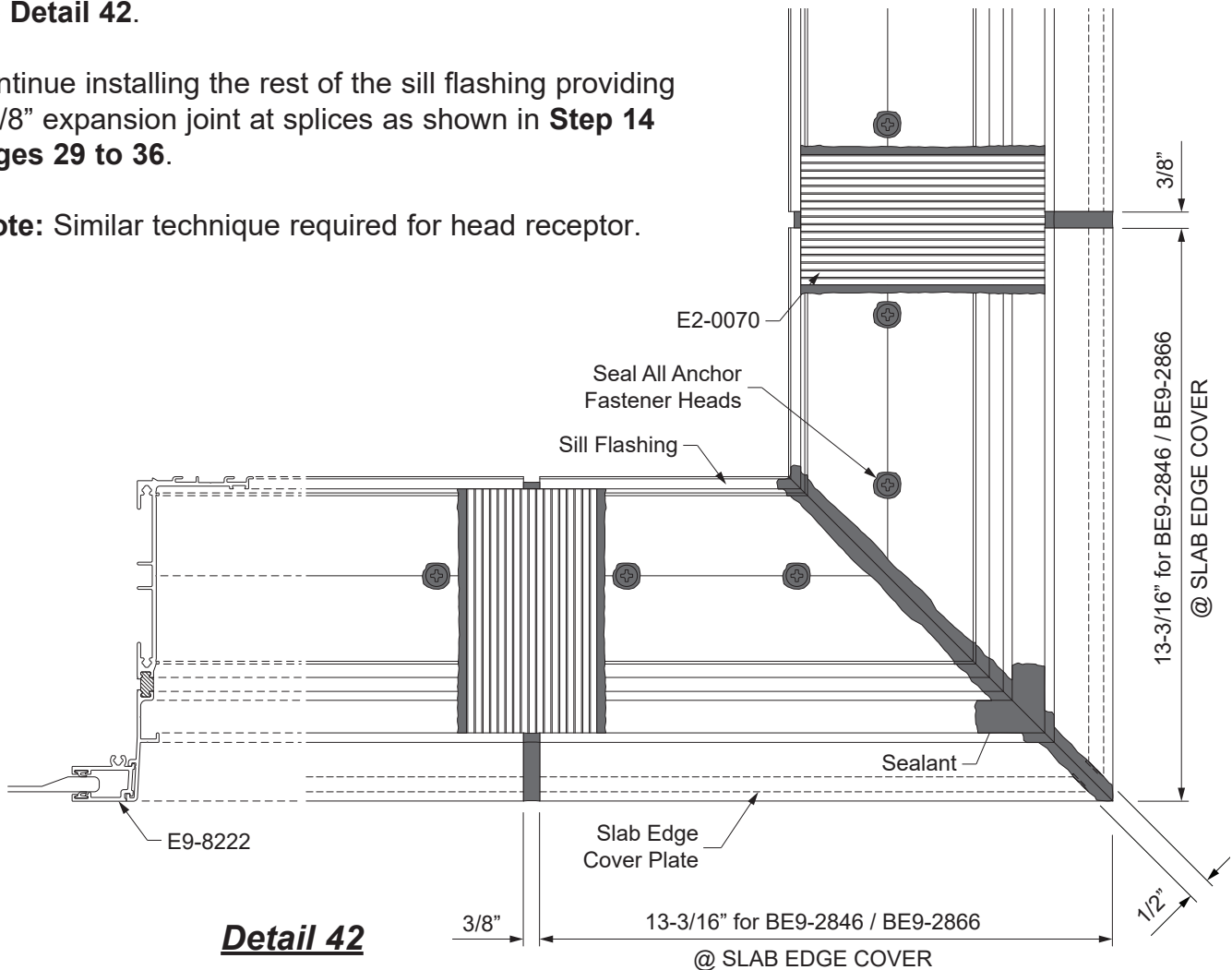

FRAME INSTALLATION

STEP 16
INSTALL ASSEMBLED FRAMES

-Clean the ends of horizontal members and attachment areas of the vertical members using a cleaner approved by the sealant manufacturer.

Make sure all the surfaces are clean.

-Apply and tool sealant to the shaded areas just prior to snapping the mullion together. Ensure the sealant does not get into the glass stop reglets of the head, horizontal, and sill.

-Snap the mullion filler into the mullion.

-Apply sealant to the inside of the glazing pocket of the horizontals at the verticals as shown in **Detail 43**.

-Tool and wipe away excess sealant at the joints.

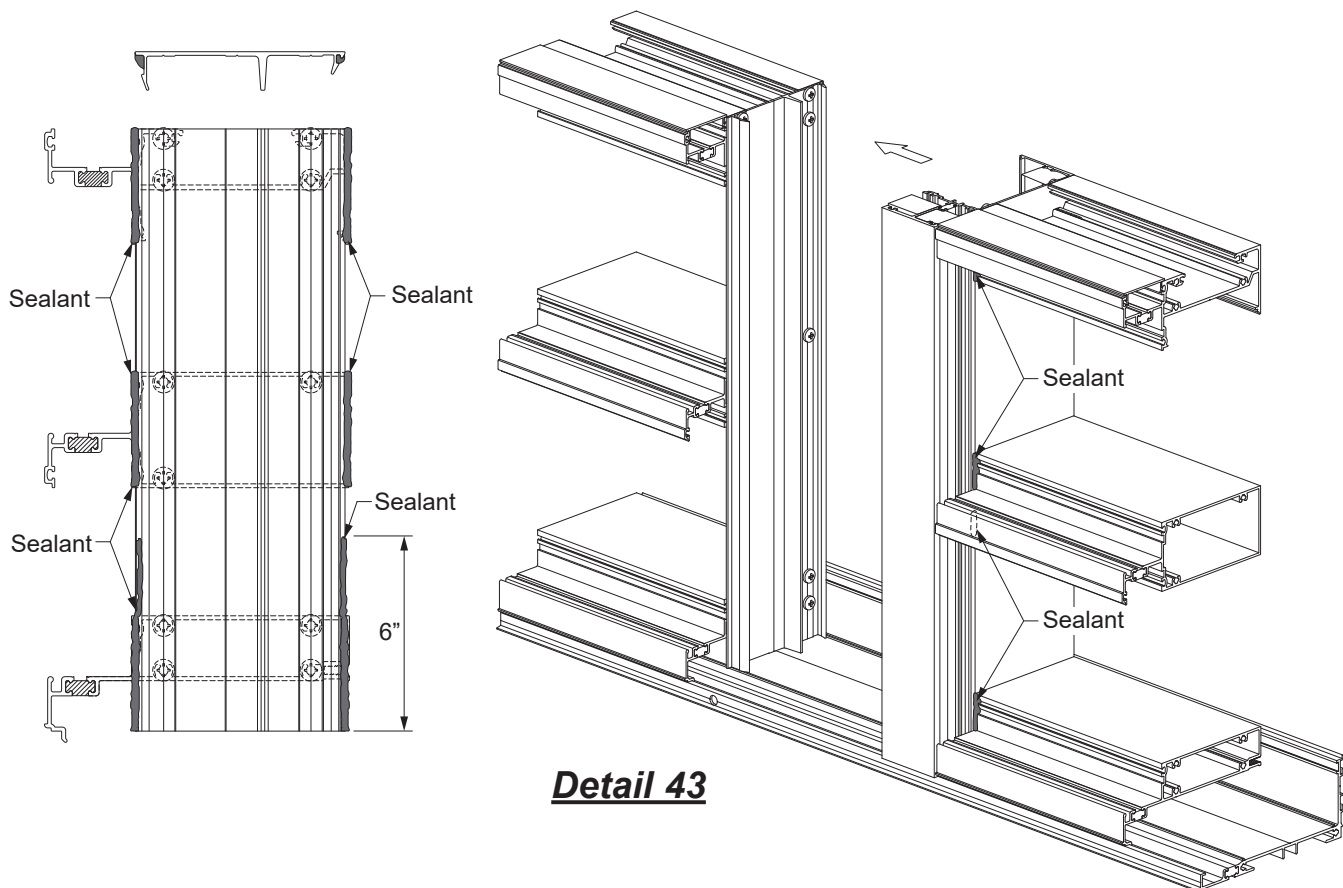

Detail 43

FRAME INSTALLATION

**STEP 17
ANCHOR / SEAL FRAMES**

- Anchor frames at the head and jambs per fasteners as specified by approved shop drawings and or P.E. calculations, providing a minimum of 3/8" shim space at the head and sill, and 1/2" minimum shim space at the jambs.
- Fasten the sill member to the sill flashing using PM-1010 fasteners, 7 per DLO. Seal the screw heads.
- Install backer rods around the perimeter of the frame.
- Apply and tool sealant to ensure a watertight seal.

Note: Interior and exterior seals are required.

See **Detail 44**.

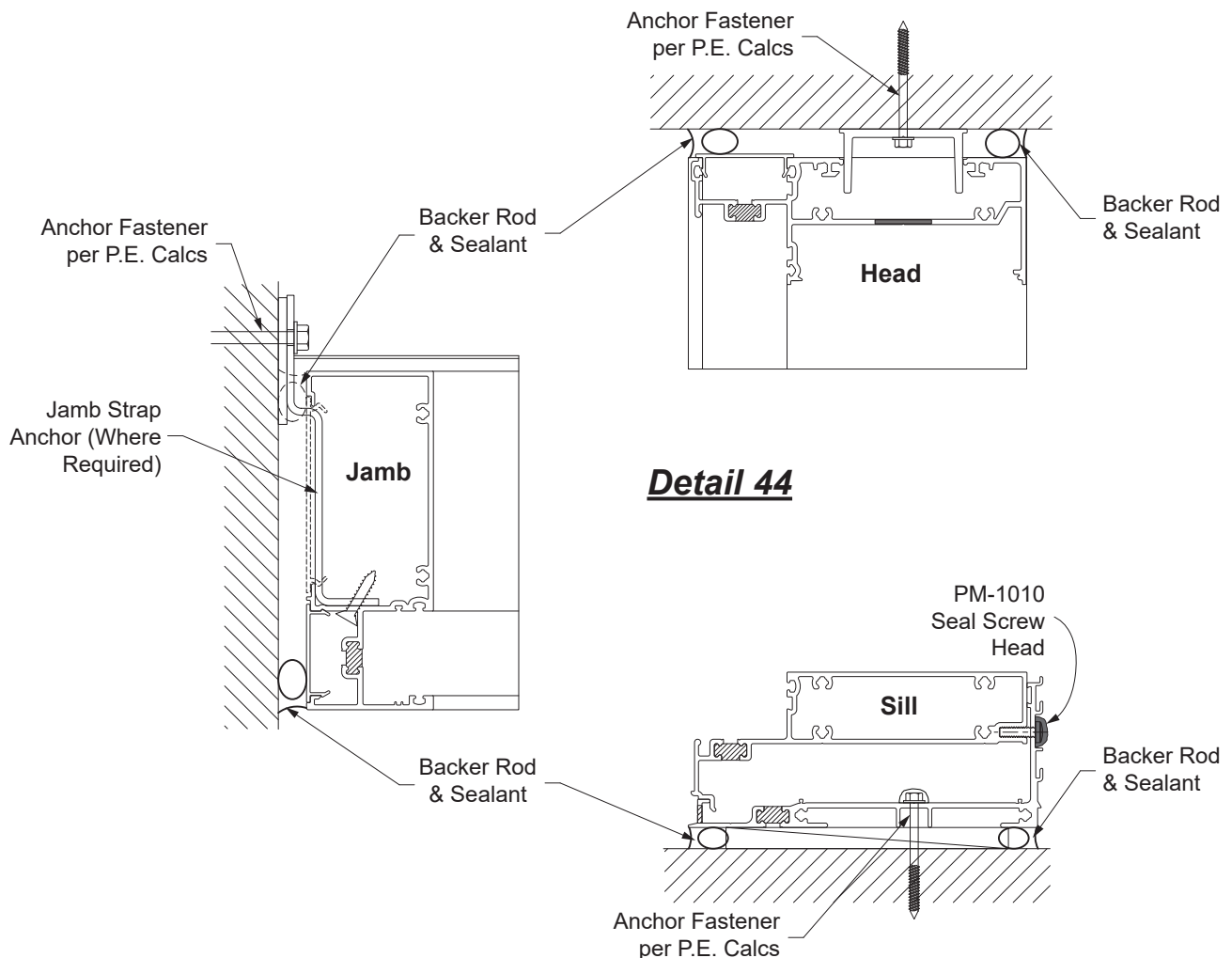

FRAME INSTALLATION

STEP 17A
ANHCOR / SEAL FRAMES AT HEAD RECEPTOR

-In the case of where a head receptor is used, secure the E9-1715 exterior glass stop to the head member with two UF-1008-SS fasteners (each at 2" from each end of the glass stop) prior to attaching the receptor snap cover and its E2-0051 bulb gasket.

See **Detail 45**.

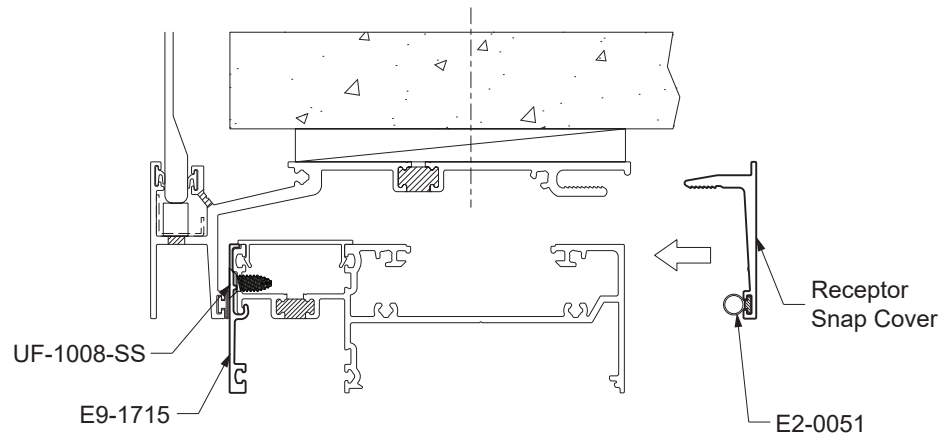

Detail 45

-At slab edge covers, install a backer rod at the interior of the sill flashing and head receptor.
-Apply and tool sealant to ensure a watertight seal.

See **Detail 46**.

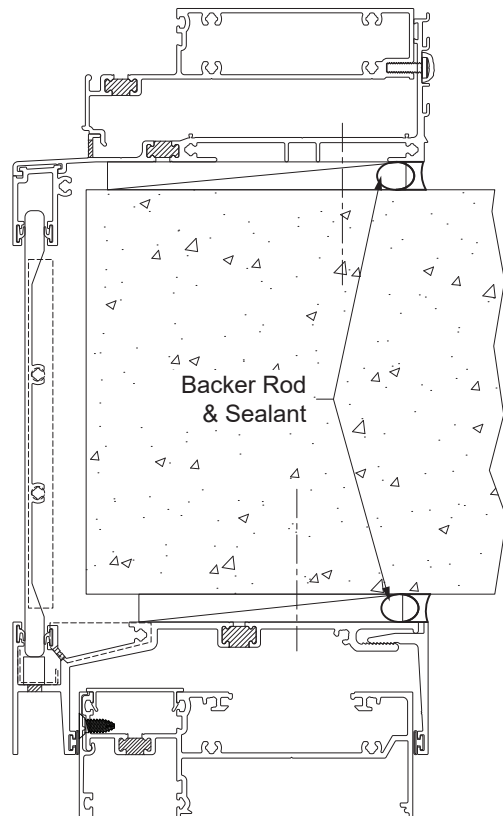

Detail 46

FRAME INSTALLATION

**STEP 17B
APPLY SEALANT AT CORNER MULLIONS**

-Apply backer rod and sealant the at the interior of the corner mullion, the full height of the mullion.
Do not seal the exterior side.

See **Detail 47**.

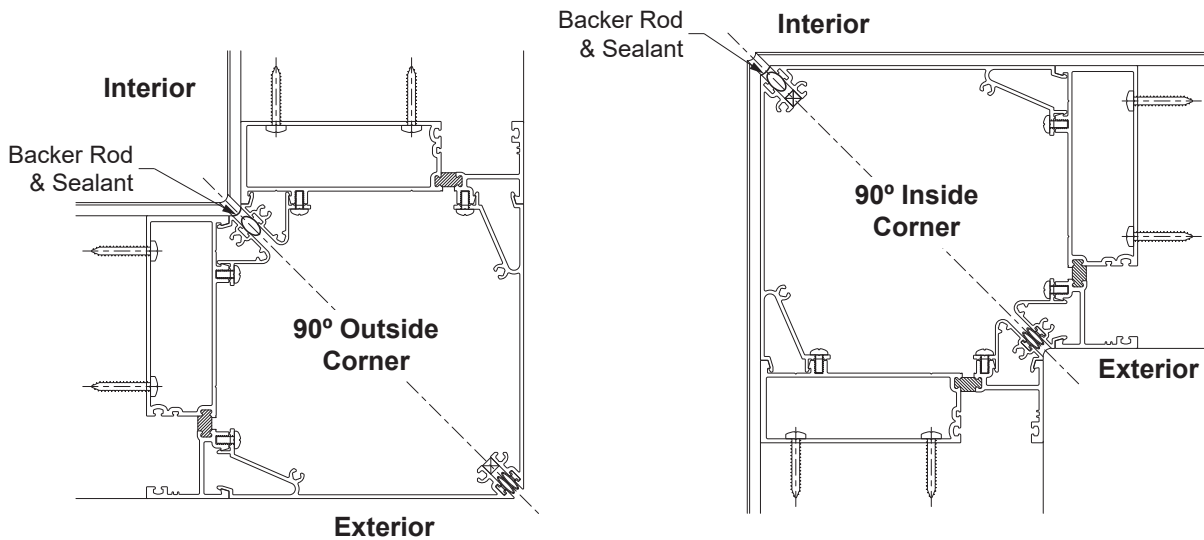

Detail 47

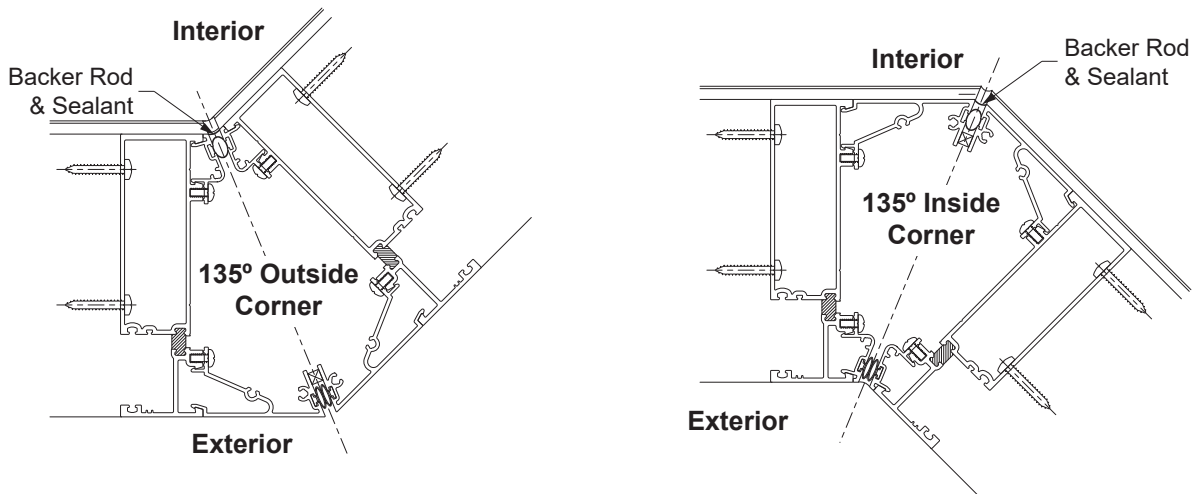

FRAME INSTALLATION

STEP 18
INSTALL WATER DEFLECTOR

YWW 50 TU and YWW 60 TU require the installation of a water deflector, E2-0047, at the ends of every intermediate horizontal to keep water off of the insulating glass units.

-Peel away the protective paper from the bottom of the water deflector, E2-0047, and install the water deflector at the ends of each horizontal. See **Detail 48**.

-Position the vertical leg of the water deflector against the end of the horizontal.

Note: For best adhesion, make sure that the horizontal is clean and dry.

-Apply and tool sealant along the edges of the deflector and down onto the horizontal. Seal the ramp of the water deflector to the glazing pocket, filling the gap at the thermal isolator as shown on **Detail 49**.

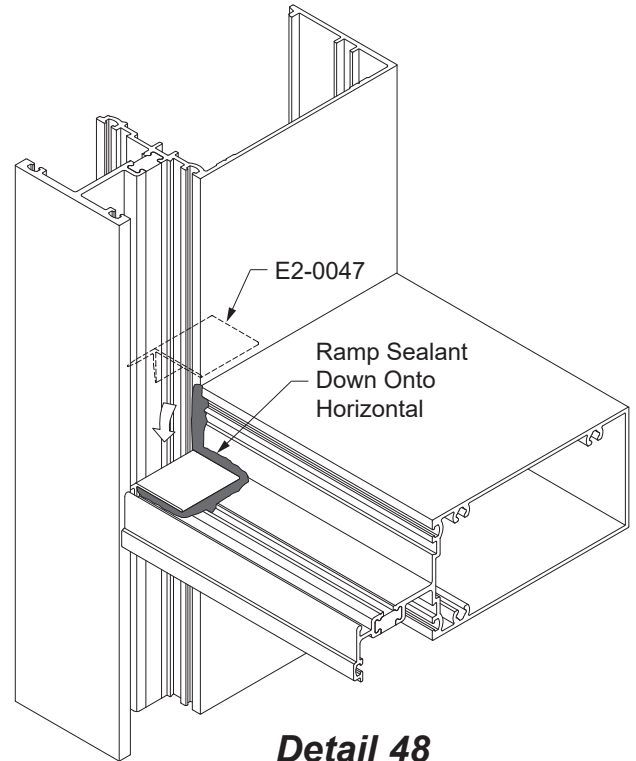

Detail 48

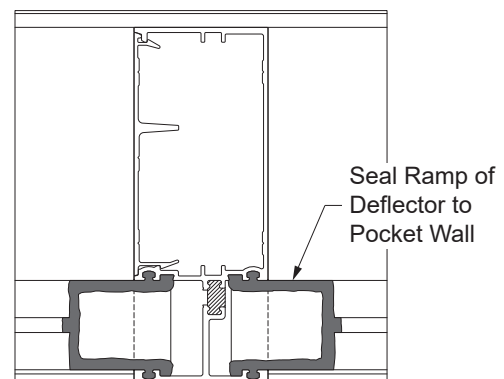

Detail 49

GLAZING

**STEP 19
INSTALL DART GASKETS**

-Using a small brush, clean out any dirt that may have accumulated in the gasket reglets.

Vertical glazing gaskets must be installed first:

- Cut vertical gaskets to the Daylight Opening plus(+) 3/4" plus(+) an additional 1/4" for each foot of length. Notch the ends of the vertical gasket as shown in **Detail 50**.
- Insert the gasket into the reglets at each end first; then insert the gasket at the midpoint of the opening.
- Push the gasket into the reglet starting at the ends and work towards the midpoint.

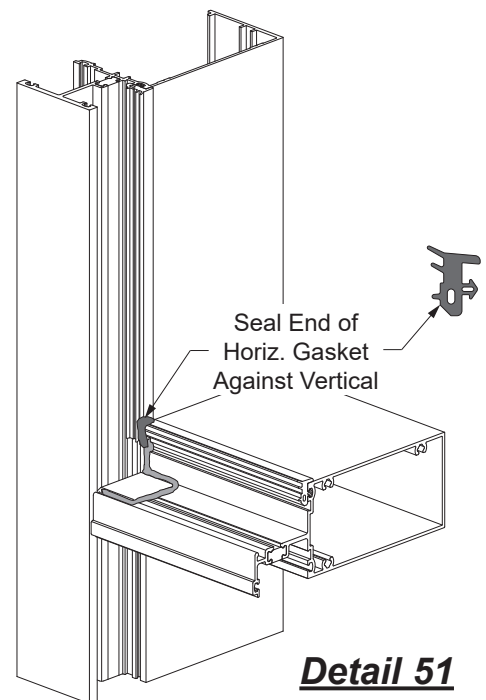
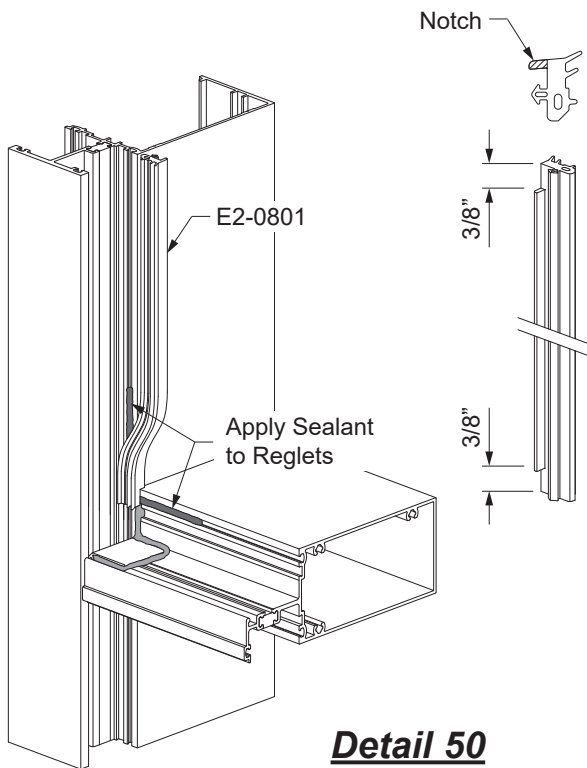

Install horizontal glazing gaskets next:

- Cut horizontal glazing gaskets to Daylight Opening plus(+) 1/4" for each foot of length.
- Apply sealant to each end of the horizontal glazing gasket prior to inserting into the reglet.
- Insert the gasket into the reglet at each end first; then insert the gasket at the midpoint of the opening.
- Tool the excess sealant at the gasket corners to ensure a watertight seal.

See **Detail 51**.

GLAZING

**STEP 20
INSTALL SETTING / SIDE BLOCKS**

Determine the glass size:

	Width	Height
Standard Glazing	D.L.O. + 7/8"	D.L.O. + 7/8"

- Apply setting blocks at 1/4 points or according to P.E. calculations.
At intermediate horizontals: E2-0150 for 1" glazing and E2-0192 for 1/4" glazing
At sill conditions: E2-0150 for 1" glazing and E2-0190 for 1/4" glazing.
- See **Detail 52**.

- Install Side blocks E2-0019 in the shallow glazing pocket of each vertical of daylight opening. (Use E2-0133 in the case of expansion mullions.)
- Carefully install the glass into the frame, making sure the setting and side blocks are aligned with the glass.

Note: Be careful not to disengage any gaskets that have already been installed when installing the glass.

After the glass is set, install one (1) E2-0546 anti-walk block at the deep pocket locations.

See **Details 52 & 53**.

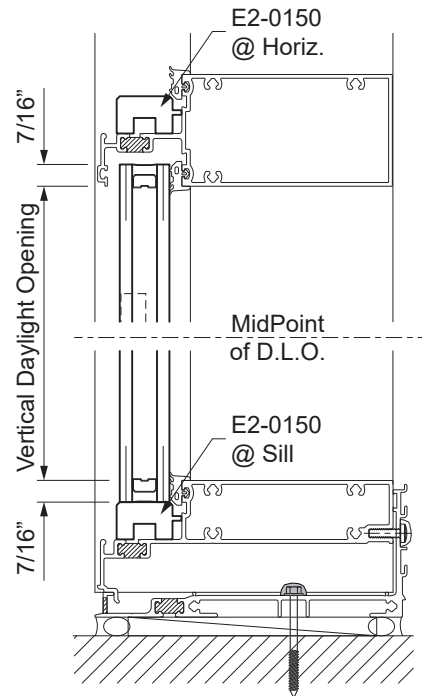

Detail 52

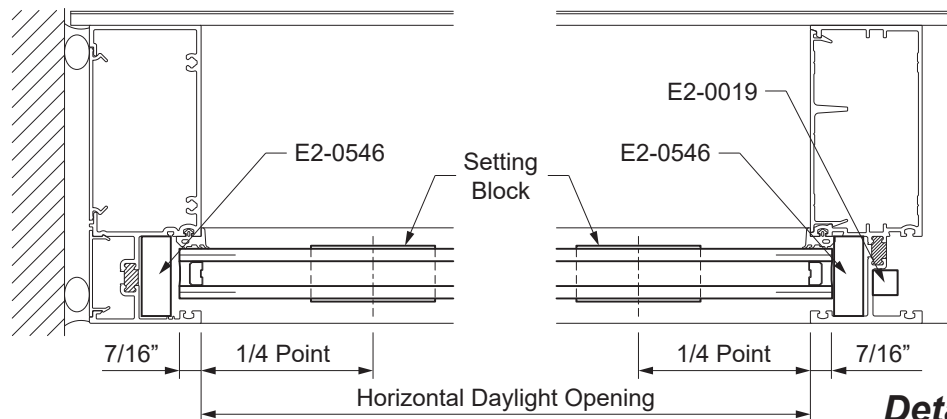

Detail 53

GLAZING

**STEP 20 (Continued)
INSTALL GLASS FOR STANDARD GLAZING**

For Interior Glazing:

Interior glass stops are required at all head and intermediate horizontals:

E9-2781 for YWW 50 TU

E9-2763 for YWW 60 TU

- Prior to snapping on the interior covers, cover the access holes for the head anchor fasteners by adhering cut pieces of E2-0070 sheets onto the head members with sealant.
- Apply sealant to each end of the glass stops and snap them into position.
- Tool the sealant into the joint between the glass stop and the vertical to ensure a watertight seal and wipe away any excess sealant.

See **Detail 54**.

- Cut the vertical wedge gasket to vertical Daylight Opening plus (+) 3/4", plus 1/4" for each foot of length. Notch the ends of the gasket as shown in **Detail 55**.

- Insert the vertical gasket into the glazing pocket, pushing the notched ends into the horizontals first, then working towards the mid point.

- Install the interior horizontal wedge gaskets, E2-0808, to the Daylight Opening plus(+) 1/4" for each foot of length, starting at the ends first and working towards the midpoint.

- Apply sealant to the ends of the horizontal wedge gaskets and finish inserting them into the glazing pocket against the vertical wedge gaskets.

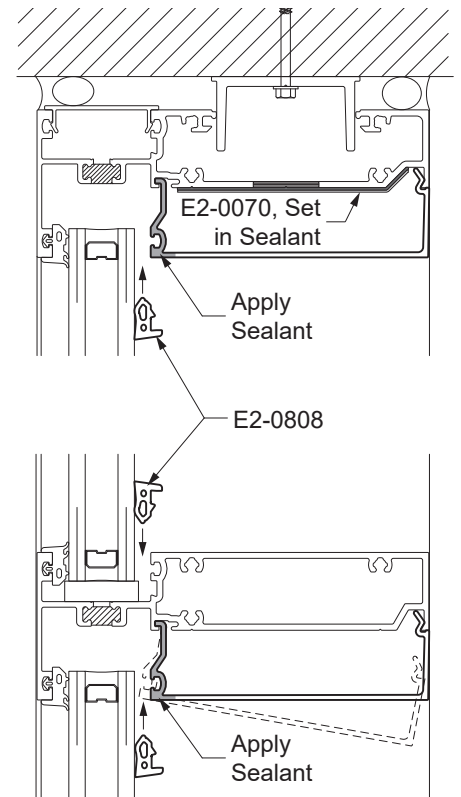

Detail 54



Detail 55

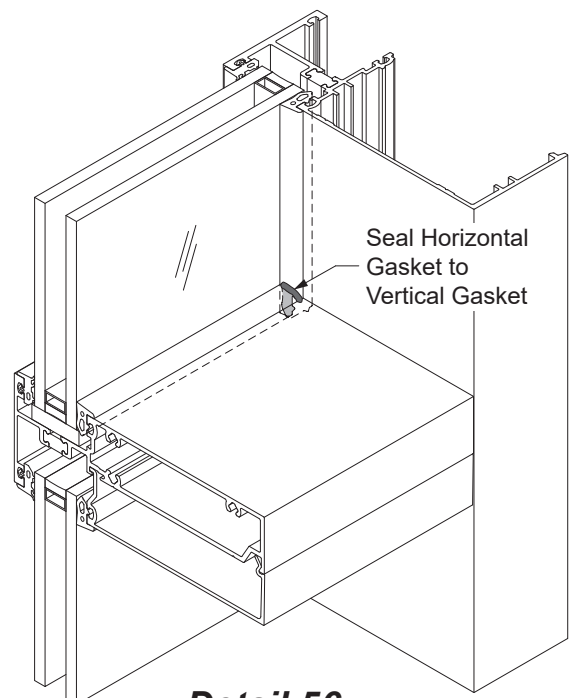

Detail 56

See **Detail 56**.

GLAZING

STEP 20 (Continued)
INSTALL GLASS FOR STANDARD GLAZING

For Outside Glazing:

Exterior glass stops are required at all head and intermediate horizontals:

E9-1715 for tubular horizontal members.

- Apply sealant to the ends of the exterior glass stop, and engage the hook of the glass stop with the ball of the horizontal members and rotate them into position.
- Apply sealant to the back of the sill member of the installed unit at the sill flashing as shown in **Detail 57**.
- Snap in the interior flat fillers into the head and sill members.
- Cut the vertical wedge gasket to vertical Daylight Opening plus (+) 3/4". Notch the ends of the gasket as previously shown in **Detail 57**.
- Insert the vertical gasket into the glazing pocket, pushing the notched ends into the horizontals.
- Install the exterior horizontal wedge gaskets, E2-0808, to the Daylight Opening plus (+) 1/4" for each foot of length, starting at the ends first and working towards the midpoint.
- Apply sealant to the ends of the horizontal wedge gaskets and finish inserting them into the glazing pocket against the vertical wedge gaskets.

See **Detail 58**.

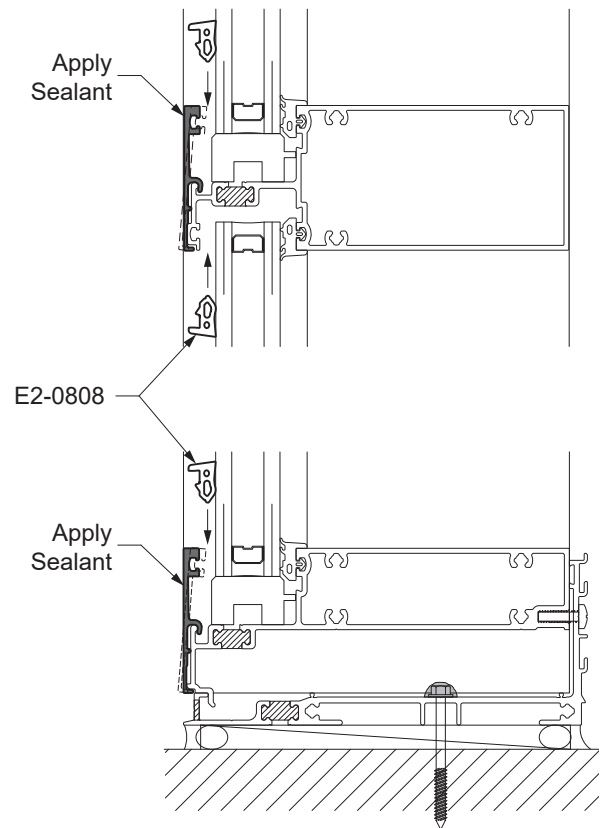

Detail 57

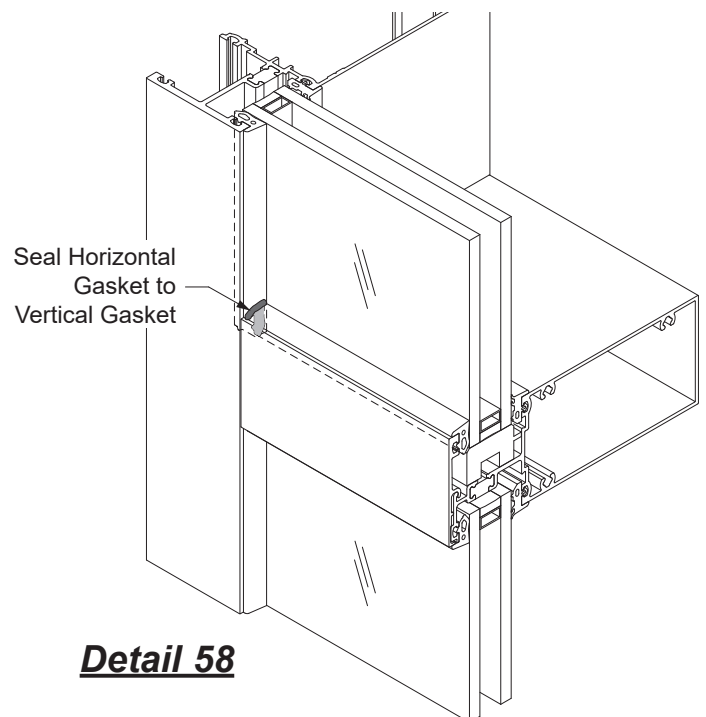

Detail 58

**STEP 21
SNAP ON INTERIOR FLASHING COVER**

-For all sill members, apply continuous sealant to the top of the back leg of the sill flashing as shown on **Detail 59**. Tool sealant and remove excess that would interfere with the installation of the interior cover. Then snap on the E9-2868 interior cover.

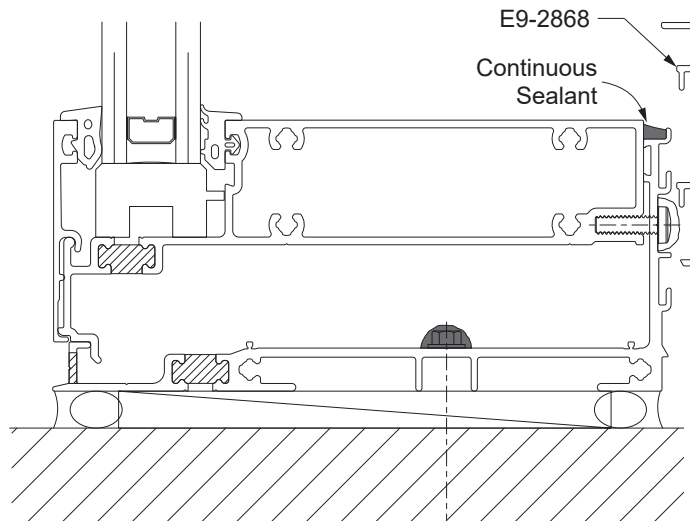
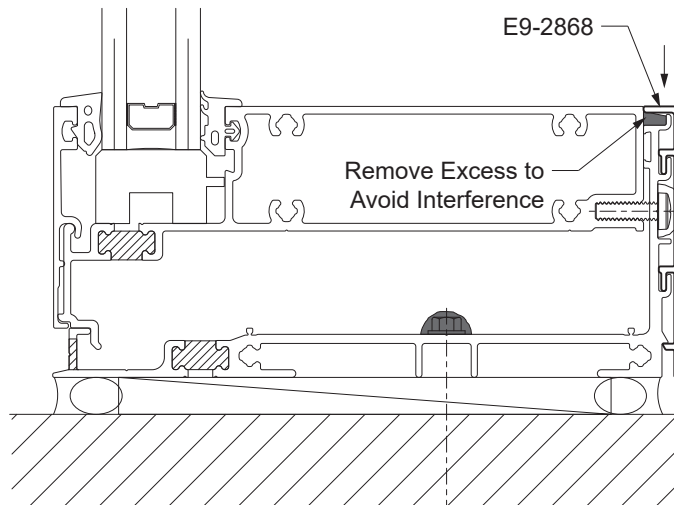
**Detail 59**

DOOR FRAME INSTALLATION

**STEP 22
INSTALL DOOR FRAME**

Doors are shipped assembled, and door frames will be fabricated and shipped knocked down. Please refer to the 20D, 35D, & 50D **Entrances Installation Manual** for door installation.

-Door jamb mullions are made from tubular mullions and their flat fillers, as shown below in **Detail 61**. Door transoms bars are made with tubular horizontals and BY7-9241 pocket filler (cut to transom horizontal length minus(-) 1/32") and E9-1715 glass stop.

- Install the BY7-9241 flat filler (cut to length and notched as shown in **Detail 60**) into the door jamb mullions.
- Install the E9-1715 glass stop and flat filler onto the transom bar.

- Install sill flashing end dams into the ends of the sill flashing using the same method as previously shown in **Step 11 on Page 24**.

See **Detail 61**.

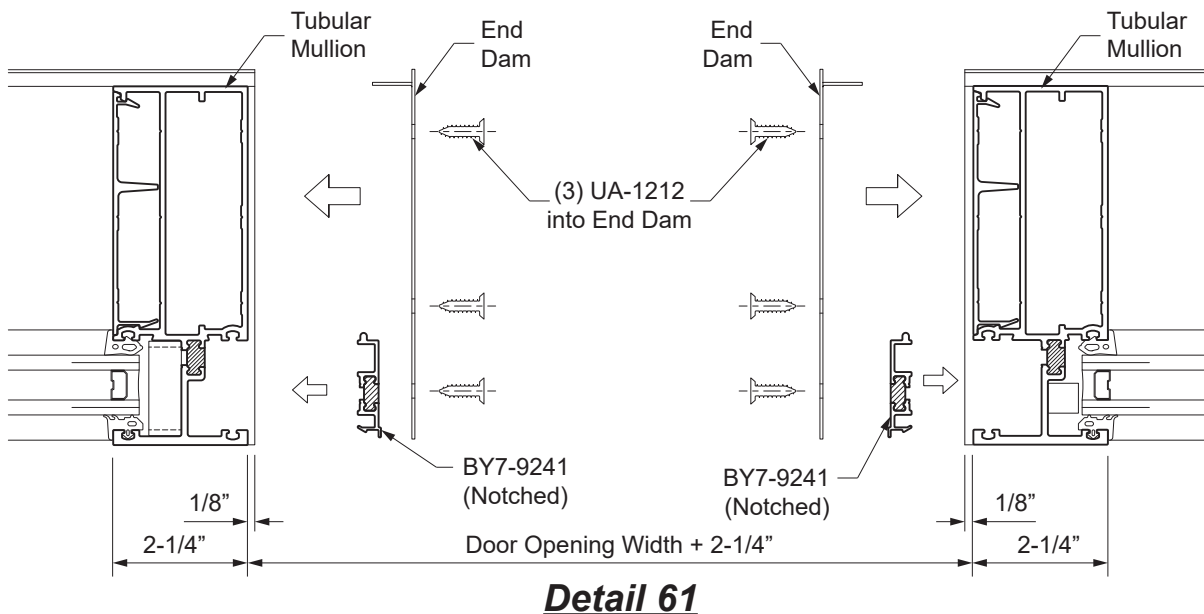
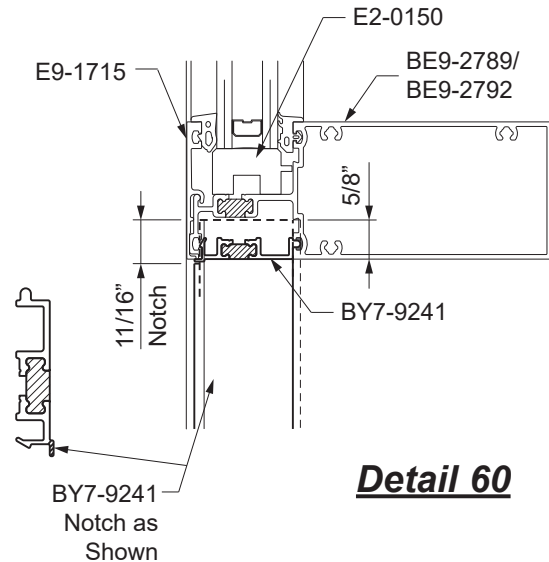

DOOR FRAME INSTALLATION

**STEP 22 (Continued)
INSTALL DOOR FRAME**

- Assemble the door subframe and install the door jamb subframes to the tubular door jambs with PC-1228 fasteners, spaced according to the approved shop drawings and or P.E. calculations. Provide a 3/8" shim space between the jamb subframes and the jamb mullions, 1/4" shim space at the transom bar. Maintain a 1/2" inset between the subframe and the front of the window wall framing.
- Snap in the AS-0417 fillers into the door jamb subframes.

See **Details 62 & 63.**

- Install backer rods between the subframes and the window wall framing, both front and back. Apply and tool sealant to the backer rods to ensure a water-tight seal.

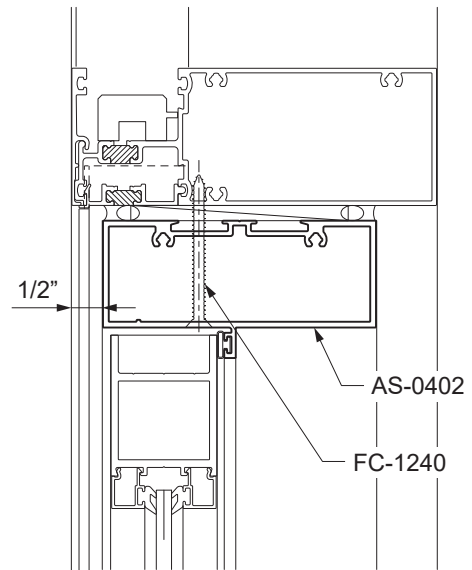

Detail 62

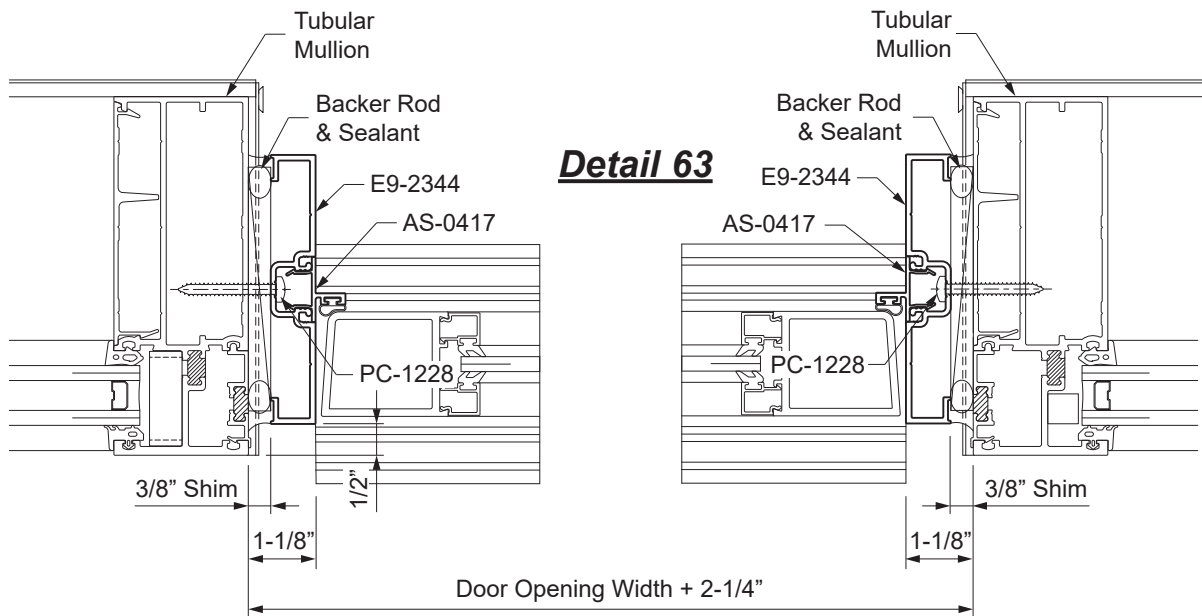

Detail 63

DOOR FRAME INSTALLATION

**STEP 23
GLAZE DOOR TRANSOM**

Door transoms for YWW 50 TU and YWW 60 TU are outside glazed only.

-Repeat **Steps 19** and **20** for gasket, setting block, and glazing instructions for the transom.

See **Details 64 & 65**.

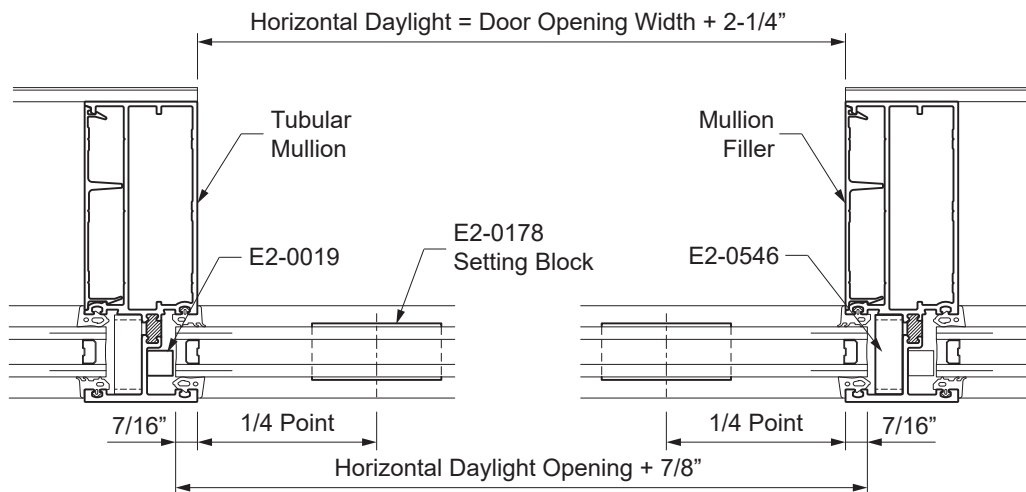
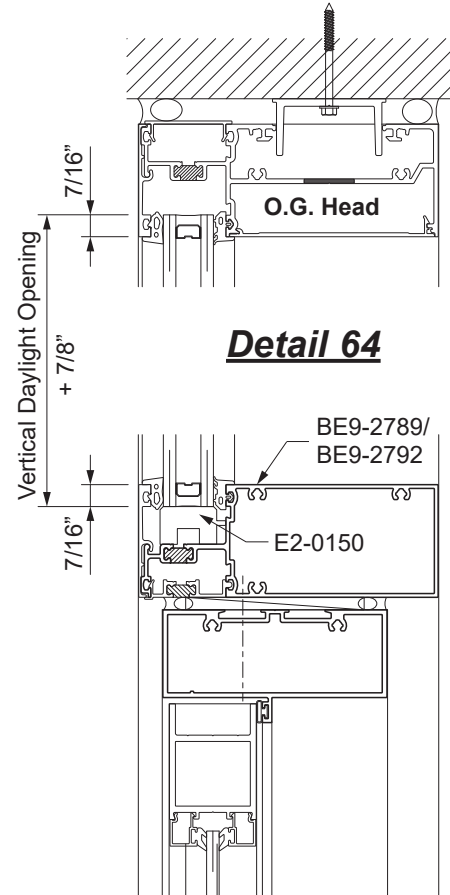

Detail 65

 **YKK AP America Inc.**

101 Marietta Street NW

Suite 2100

Atlanta, Georgia 30303

www.ykkap.com