

## YWW 60 XT Window Wall Installation Manual Preglazed Captured

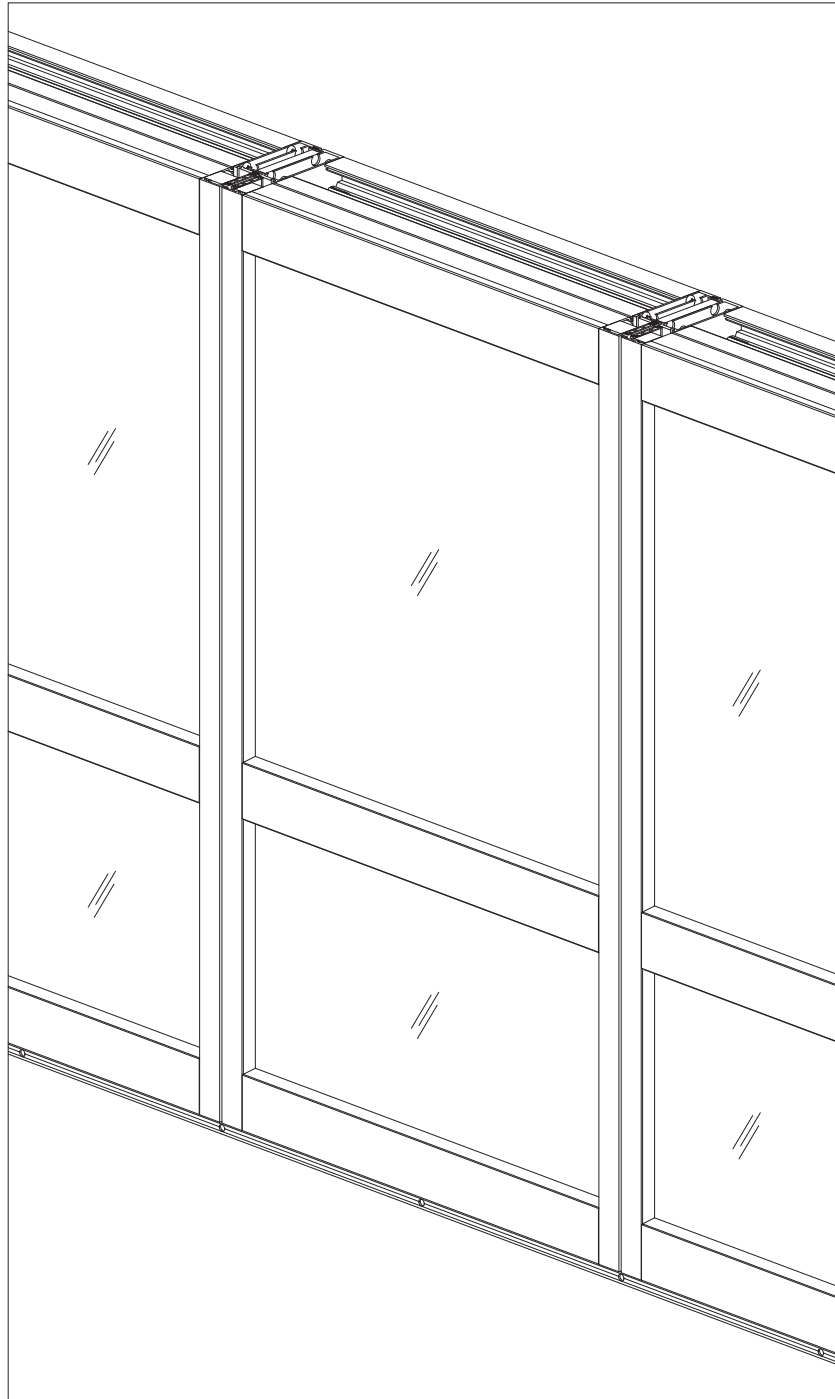



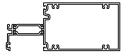

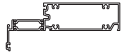
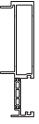
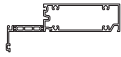

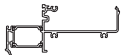

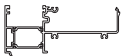
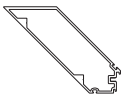





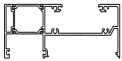

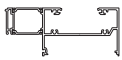



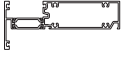

**TABLE OF CONTENTS**

Installation Notes.....	Page ii
<b>PARTS DESCRIPTION</b>	
Framing Members.....	Pages 1 & 2
Accessories.....	Pages 3 & 4
Glazing Chart.....	Page 5
<b>FRAME FABRICATION</b>	
Determine Frame Size.....	Pages 6 & 7
Fabricate Vertical Members.....	Pages 8 & 10
Fabricate Horizontals.....	Pages 11 to 12
Fabricate Glass Stops.....	Page 13
Fabricate Sill Flashing.....	Page 14
Fabricate Slab Edge Plate Adaptor.....	Page 15
Fabricate Corner Adaptors.....	Page 15
Fabricate Head Receptors.....	Page 16
<b>FRAME ASSEMBLY</b>	
Assemble Frame.....	Pages 17 to 21
Install Steel Reinforcing (Optional).....	Page 22
Install Perimeter Fillers.....	Page 23
Install Corner Adaptors.....	Page 23
Install Corner End Caps.....	Page 24
Install Weather Seal.....	Page 25
Install Foam Plugs at Head.....	Page 26
Install Water Deflector.....	Page 27
Install Dart Gaskets.....	Pages 28 & 29
<b>GLAZING</b>	
Install Setting / Side Blocks.....	Pages 30 & 31
Install Glass.....	Pages 32 & 33
Install Setting Blocks (Outside Glazing).....	Page 34
Install Anti-Walk Blocks.....	Pages 35 & 36
Install Glass Stops (Outside Glazing).....	Page 37
Install Glass Stops (Inside Glazing).....	Page 38
Seal Glass to PVC Fillers at Jambs.....	Page 39
Install Wedge Gaskets.....	Pages 40 to 41
<b>FRAME INSTALLATION</b>	
Install Sill Flashing End Dams.....	Page 42 & 43
Install Sill Flashing.....	Page 44
Install Flashing Splice Sleeve.....	Pages 44 & 45
Install Slab Edge Covers.....	Pages 46 to 52
Install Sill Flashing at Corners.....	Pages 53 & 54
Sill Preparation.....	Pages 55
Install Frames.....	Pages 56 to 61
Apply Perimeter Sealant.....	Pages 62 to 63
Seal Head Anchor Access Holes.....	Page 64
Apply Sealant at Corner Mullions.....	Page 65
Install Interior Covers.....	Page 66
<b>DOOR FRAME INSTALLATION</b>	
Install Door Frame.....	Pages 67 & 68
Glaze Door Transom.....	Page 69











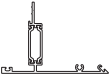









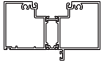

## Installation Notes

1. Do not drop, roll or drag boxes of aluminum framing. Move and stack boxes with proper support to prevent distortion. If fork lifts are used, be especially careful about striking the boxes when lifting or moving.
2. Store in a dry, out of the way area. If rain exposure, condensation or any water contact is likely, then all packaging material should be removed. Wet packaging materials will discolor and may stain aluminum finishes and paints.
3. All materials should be checked for quality and quantity upon receipt, YKK AP must be notified immediately of any discrepancies in shipment. Check to make sure that you have the required shims, sealants, supplies and tools necessary for the installation.
4. Carefully check the openings and surrounding conditions that will receive your material. Remember, if the construction is not per the construction documents, it is your responsibility to notify the general contractor in writing. Any discrepancies must be brought to the general contractor's attention before you proceed with the installation.
5. Gather your shop drawings, materials, packing list, and this installation manual. Carefully review parts location, the sequence it goes therein, when you glaze it and how you seal it. Installation instructions are of a general nature and may not cover every condition you will encounter. The shop drawings and/or installation manuals were prepared specifically for the product.
6. Any material substitutions must be of equal or greater quality.
7. Make certain that material samples have been sent for compatibility testing for all manufacturer's sealants involved. Make certain sealants have been installed in strict accordance with the manufacturer's recommendations and specifications.
8. Remember to isolate, in an approved manner, all aluminum from uncured masonry or other incompatible materials.
9. System-to-structure fasteners are not supplied by YKK AP. Fasteners called out on shop drawings are to indicate minimum sizes for design loading.
10. If any questions arise concerning YKK AP products or their installation, contact YKK AP for clarification before proceeding.
11. YKK AP storefront and/or curtain wall framing is typically completed before drywall, flooring and other products which may still be in process. Take the extra time to wrap and protect the work produced.
12. Cutting tolerances are plus zero, minus one thirty second unless otherwise noted.
13. Check our website, [www.ykkap.com](http://www.ykkap.com), for the latest installation manual update prior to commencing work.

YWW 60 XT FRAMING MEMBERS

	<b>Female Mullion</b> Used with BE9-6306 Mullion	<b>BE9-6303</b>		<b>Horizontal (OG)</b>	<b>BE9-6321</b>
	<b>Female Tubular Mullion</b> Used with BE9-6306 Mullion	<b>BE9-6308</b>		<b>Optional Horizontal (IG/OG)</b> Not Re-glazable from Outside w/ Head Receptor	<b>BE9-6351</b>
	<b>Male Mullion</b> Used with BE9-6303 & BE9-6308 Mullion	<b>BE9-6306</b>		<b>Optional Horizontal (IG/OG)</b> For Reglaze	<b>BE9-6324</b>
	<b>Jamb Mullion</b> 2-1/2" x 6"	<b>BE9-6311</b>		<b>Sill (IG/OG)</b>	<b>BE9-6327</b>
	<b>Tubular Jamb Mullion</b> 2-1/2" x 6"	<b>BE9-6313</b>		<b>Sill (IG)</b>	<b>BE9-6353</b>
	<b>90° Corner Mullion Half</b>	<b>E9-6344</b>		<b>Sill Flashing</b>	<b>BE9-6328</b>
	<b>135° Corner Mullion Half</b>	<b>E9-6345</b>		<b>Sill Flashing for Slab Edge</b>	<b>BE9-6330</b>
	<b>Head (IG)</b>	<b>BE9-6347</b>		<b>Head Receptor</b>	<b>BE9-6329</b>
	<b>Head (OG)</b>	<b>BE9-6315</b>		<b>Head Receptor w/ Plate Adaptor</b>	<b>BE9-6331</b>
	<b>Optional Head (OG)</b>	<b>BE9-6367</b>		<b>Receptor Snap Cover</b> Used with BE9-6329 & BE9-6331	<b>E9-6343</b>
	<b>Optional Head (IG/OG)</b>	<b>BE9-6318</b>		<b>Flashing Interior Face Cover</b> Used with BE9-6328 & BE9-6330	<b>E9-6342</b>
	<b>Horizontal (IG)</b>	<b>BE9-6350</b>		<b>Optional Sill Flashing Interior Face Cover</b> Used with BE9-6328 & BE9-6330	<b>E9-6346</b>

YWW 60 XT FRAMING MEMBERS (Continued)

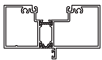





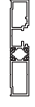



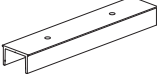
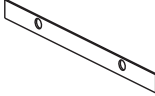
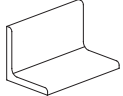
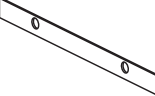
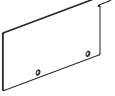
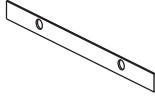
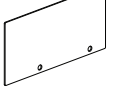

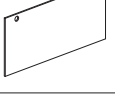

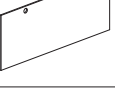

	<b>90° Corner Cover</b>	<b>BE9-6334</b>		<b>6-1/8" Slab Edge Cover</b>	<b>E9-8059</b>
	<b>135° Corner Cover</b>	<b>BE9-6336</b>		<b>6-5/8" Slab Edge Cover</b>	<b>E9-7723</b>
	<b>Corner Mullion</b>	<b>BE9-6374</b>		<b>7-3/8" Slab Edge Cover</b>	<b>E9-8223</b>
	<b>90° Inside Corner Adaptor</b>	<b>BE9-6375</b>		<b>7-7/8" Slab Edge Cover</b>	<b>E9-8231</b>
	<b>135° Inside Corner Adaptor</b>	<b>BE9-6376</b>		<b>8" Slab Edge Cover</b>	<b>E9-8589</b>
	<b>90° Corner Cover (Large)</b>	<b>E9-2740</b>		<b>9" Slab Edge Cover</b>	<b>E9-8428</b>
	<b>135° Corner Cover (Large)</b>	<b>E9-2742</b>		<b>Head Anchor</b>	<b>E9-6340</b>
	<b>Glass Stop</b>	<b>E9-7852</b>		<b>4-1/2" x 2-1/4" Door Head</b> For 35XT/50XT Doors* E2-0051 Not Included	<b>BE9-1532</b>
	<b>Interior Cover</b>	<b>E9-6339</b>		<b>Door Jamb Adaptor</b> For 35XT/50XT Doors* E2-0051 Not Included Use with BE9-1540	<b>BE9-1533</b>
	<b>Flush Filler</b>	<b>E9-6337</b>		<b>Narrow Door Jamb</b> For 35XT/50XT Doors* Use with BE9-1533	<b>BE9-1540</b>
	<b>Exterior Glass Stop</b>	<b>E9-6338</b>		<b>Pocket Filler</b>	<b>BE9-6365</b>
	<b>Aluminum Plate Adaptor</b> For BE9-6330	<b>E9-8222</b>		<b>Single Acting Transom Bar</b> For 25T/35T/50T Doors E2-0051 Not Included	<b>BE9-2582</b>

\*Note: 35XT/50XT Doors to be discontinued after April 30, 2024.

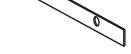

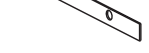

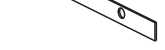





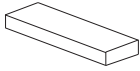
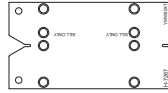
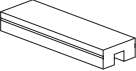







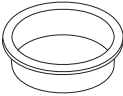

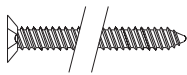

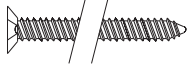
YWW 60 XT FRAMING MEMBERS (Continued)

	<p><b>Door Jamb Flat Subframe</b> For 25T/35T/50T Doors Use with AS-1539</p>	<p><b>BE9-1526</b></p>		<p><b>Door Stop</b> For 25T/35T/50T Doors E2-0051 Included Use with BE9-1526</p>	<p><b>AS-1539</b></p>
---	--	------------------------	---	--	-----------------------

ACCESSORIES







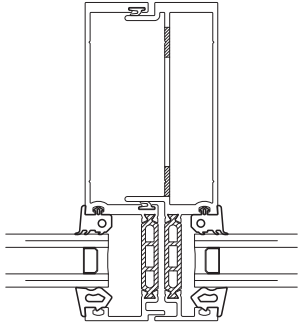
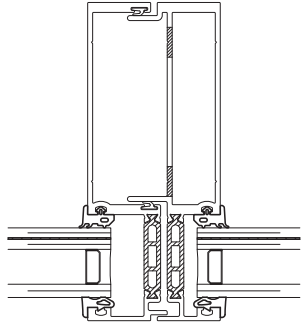

	<p><b>Head Anchor</b> 10" Cut Length</p>	<p><b>E1-2830</b></p>		<p><b>End Cap</b> For E9-8231 Slab Edge Cover Plate</p>	<p><b>E1-9954</b></p>
	<p><b>Door Jamb Mullion Anchor (3-1/2")</b></p>	<p><b>E1-2819</b></p>		<p><b>End Cap</b> For E9-8589 Slab Edge Cover Plate</p>	<p><b>E1-9955</b></p>
	<p><b>End Dam</b> For Sill Flashing</p>	<p><b>E1-2820</b></p>		<p><b>End Cap</b> For E9-8428 Slab Edge Cover Plate</p>	<p><b>E1-9956</b></p>
	<p><b>End Dam</b> For Sill Flashing @ Door Jamb</p>	<p><b>E1-2826</b></p>		<p><b>90° Corner Half End Cap</b></p>	<p><b>E1-2824</b></p>
	<p><b>End Cap</b> For BE9-6329 Head Receptor</p>	<p><b>E1-2821</b></p>		<p><b>135° Corner Half End Cap</b></p>	<p><b>E1-2825</b></p>
	<p><b>End Cap</b> For BE9-6331 Head Receptor</p>	<p><b>E1-2822</b></p>		<p><b>PVC Back Jamb Filler</b></p>	<p><b>E3-3667</b></p>
	<p><b>End Cap</b> For Head Receptor</p>	<p><b>E1-2823</b></p>		<p><b>Head Receptor Splice Sleeve</b> For Slab Edge</p>	<p><b>E1-9961</b></p>
	<p><b>End Cap</b> For Slab Edge Sill Flashing Adaptor</p>	<p><b>E1-1196</b></p>		<p><b>Silicone Splice Sleeve</b></p>	<p><b>E2-0070</b></p>
	<p><b>End Cap</b> For E9-8059 Slab Edge Cover Plate</p>	<p><b>E1-9984</b></p>		<p><b>Setting Block Chair</b> For 1" Glazing</p>	<p><b>E1-2831</b></p>
	<p><b>End Cap</b> For E9-7723 Slab Edge Cover Plate</p>	<p><b>E1-9985</b></p>		<p><b>Setting Block Chair</b> For 1-5/16" Glazing</p>	<p><b>E1-2833</b></p>
	<p><b>End Cap</b> For E9-8223 Slab Edge Cover Plate</p>	<p><b>E1-9953</b></p>		<p><b>Setting Block</b> For 1" Glazing</p>	<p><b>E2-0704PC</b></p>

ACCESSORIES (Continued)

	<b>Setting Block</b> For 1-5/16" Glazing	E2-0611		<b>Drill Fixture</b>	H-7267
I.D. 	<b>Setting Block</b> For Top of Glass	E2-0068		<b>Drill Fixture</b> For 90° Corner Mullion	H-7268
	<b>Setting Block</b> For Shipping	E2-0020		<b>#10" x 3/8" PHMS</b> Stainless Steel, For Corner Cover Attachment	PM-1006 -SS
	<b>Setting Block</b> For Slab Edge Cover	E2-0054		<b>#12 x 3/4" UFHSMS</b> Type A, Zinc Plated Steel, For End Dam Attachment	UA-1212
	<b>Water Deflector</b>	E2-0049		<b>#10 x 3/8" FHSMS Type AB</b> For Corner End Cap Installation	FC-1006
	<b>1-1/2" Air Seal Plug</b>	E3-1166		<b>#12 x 1-3/4" FHSMS</b> Type AB, Zinc Plated Steel, For Corner Frame Assembly	PC-1228
	<b>Foam Backer Tape</b> 1" x 1-1/4" (Roll)	E2-0259		<b>#12 x 2-1/4" FHSMS</b> Type AB, Zinc Plated Steel, Used at Door Jamb	FC-1236
	<b>1/4" x 1/4" Spacer Tape</b>	E2-0110		<b>#12 x 3-1/2" FHSMS</b> Type AB, Zinc Plated Steel, Used at Door Transom Bar	FC-1256
	<b>Anti-Walk Block</b> For Female Mullion and Jamb Mullion	E2-0546		<b>#10 x 1/2" PHSMS Type AB</b> , Zinc Plated Steel, For Sill Flashing Attachment	PC-1008
	<b>Side Block</b> For Male Mullion	E2-0133		<b>#12 x 5/8" PHSMS Type AB</b> , Zinc Plated Steel	PC-1210
	<b>Airtight Gasket</b>	E2-0051		<b>#12 x 1-1/4" PHSMS</b> Type AB, Zinc Plated Steel	PC-1220
	<b>Weathering Gasket</b> For Slab Edge Cover	E2-0065		<b>"This Side Down"</b> Static Label	E4-0008
	<b>Weep Baffle</b>	E2-0099			

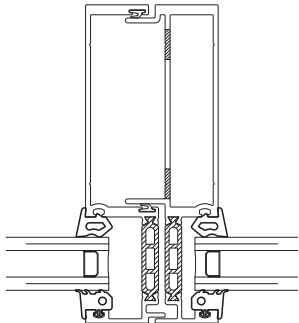
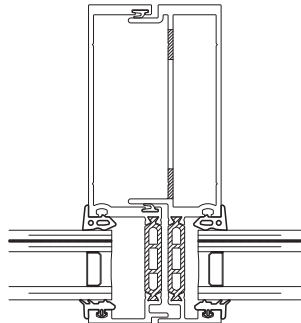

GLAZING CHART

1" Insulating Glass			1-5/16" Laminated Insulating Glass		
<p style="text-align: center;"><b>Outside Glazing</b></p> 			<p style="text-align: center;"><b>Outside Glazing</b></p> 		
Interior Gasket		<p style="text-align: center;"><b>E2-0811</b>  <b>Dart Gasket (EPDM)</b>                      3/8" F.C.</p>	Interior Gasket		<p style="text-align: center;"><b>E2-0801</b>  <b>Dart Gasket (EPDM)</b>                      1/4" F.C.</p>
Exterior Gasket		<p style="text-align: center;"><b>E2-0818</b>  <b>Wedge Gasket (EPDM)</b>                      3/8" F.C.</p>	Exterior Gasket		<p style="text-align: center;"><b>E2-0195</b>  <b>Wedge Gasket (EPDM)</b>                      3/16" F.C.</p>
<p style="text-align: center;"><b>Inside Glazing</b></p> 			<p style="text-align: center;"><b>Inside Glazing</b></p> 		
Interior Gasket		<p style="text-align: center;"><b>E2-0818</b>  <b>Wedge Gasket (EPDM)</b>                      3/8" F.C.</p>	Interior Gasket		<p style="text-align: center;"><b>E2-0808</b>  <b>Wedge Gasket (EPDM)</b>                      1/4" F.C.</p>
Exterior Gasket		<p style="text-align: center;"><b>E2-0811</b>  <b>Dart Gasket (EPDM)</b>                      3/8" F.C.</p>	Exterior Gasket		<p style="text-align: center;"><b>E2-9801</b>  <b>Dart Gasket (EPDM)</b>                      3/16" F.C.</p>

## FRAME FABRICATION

### STEP 1 DETERMINE FRAME SIZE

#### Determine Frame Width:

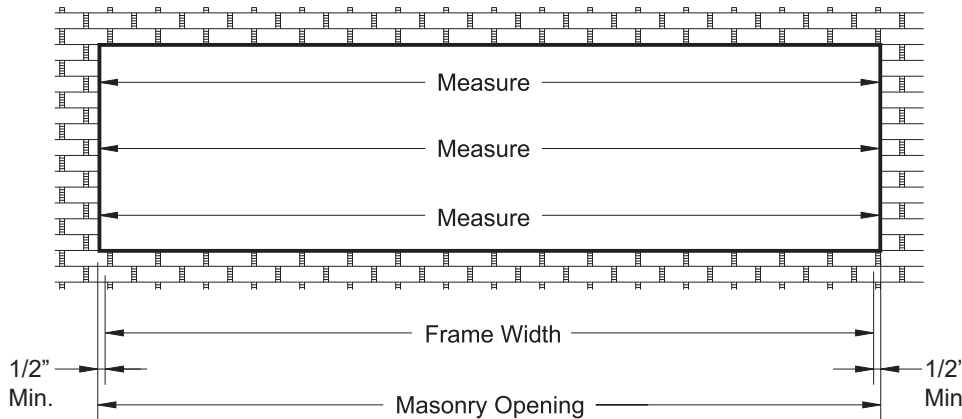

**Note:** Check opening for squareness of plumb at both ends, units must be installed in a true rectangle.

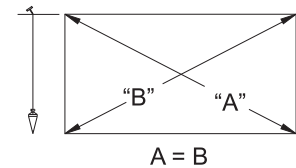

**DETAIL 1**

- Measure the width of the masonry opening at the top, middle, and bottom.
  - Select the smallest dimension measured and subtract 1" to determine the frame width.
- See **Detail 1**.

**Note:** For additional possibilities such as slab edge cover application, it is recommended to increase the caulk joint at the jambs to facilitate installation of the last framed unit. (Unit width will proportionally affect caulk joint width.)

#### Determine Frame Height for Non-Head Receptor Conditions:

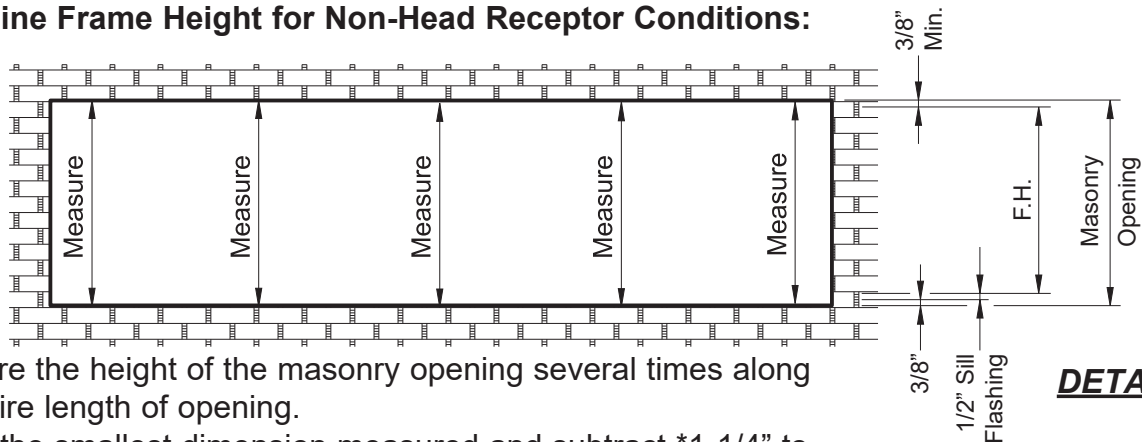

- Measure the height of the masonry opening several times along the entire length of opening.
- Select the smallest dimension measured and subtract \*1-1/4" to determine the frame height to be used.

Minimum of 3/8" shim/caulk joint at the head.

1/2" for the sill flashing.

Minimum 3/8" shim/caulk joint below the sill flashing.

See **Detail 2**.

\* **Note:** 1-1/4" is based on 3/8" perimeter caulk joint, without use of head receptor, which can vary per project.

FRAME FABRICATION

STEP 1 (Continued)  
DETERMINE FRAME SIZE

Determine Frame Height for Slab Edge Cover Conditions:

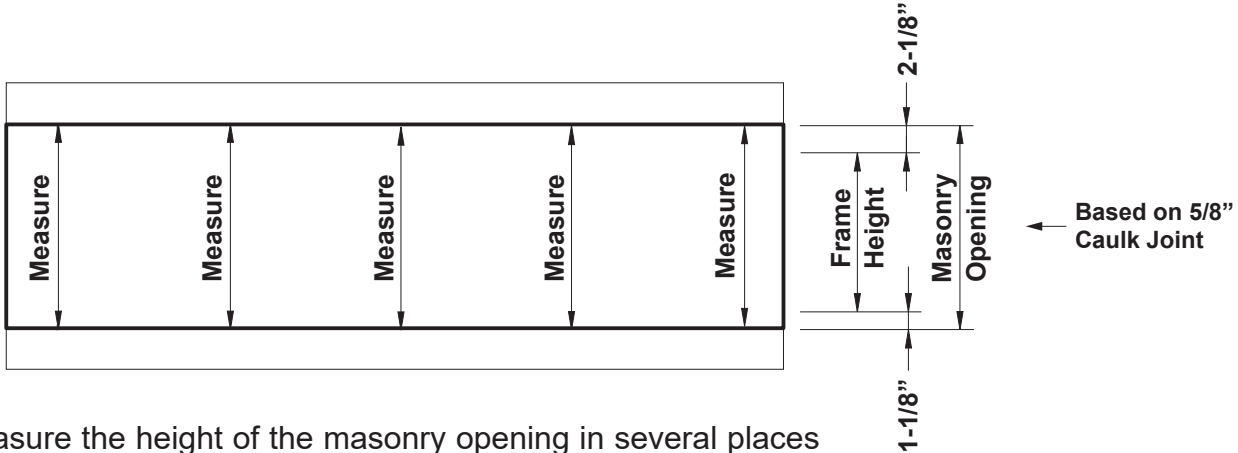

- Measure the height of the masonry opening in several places along the entire length of the opening.
- Select the smallest dimension measured and subtract \*3-1/4" to determine the frame height to be used:
  - 5/8" for the shim/caulk joint at the head.
  - 5/8" for the shim/caulk joint below the sill flashing.

See **Detail 3**.

\* **Note:** 3-1/4" is based on 5/8" perimeter caulk joint, which can vary per project.

**Detail 3**

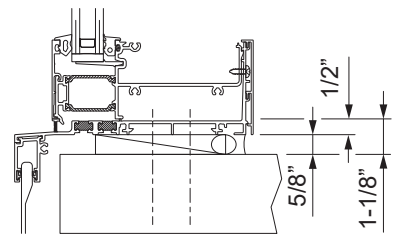
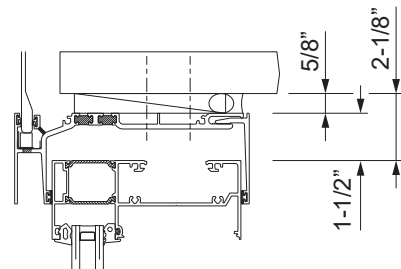

**FRAME FABRICATION**

**STEP 2  
FABRICATE VERTICAL MEMBERS**

- Cut all jamb and two piece vertical members to the frame height determined in **Step 1**.
- Fabricate holes in the vertical members for screw spline attachment using one of the methods below:
  - Using the H-7267 drill fixture as a template, line up the glazing pockets and mark hole locations through the screw splines of the templates.
- OR**
- Layout hole locations on vertical members as shown in **Detail 4**.
- Drill 0.236" diameter (#B drill bit) holes at each location marked.

**Notes:** A square cut piece of head, horizontal or sill clamped to the mullion can also be used. Additional fabrication will be required for the inclusion of steel reinforcing.

\* Tops of mullions with access holes will have sharp edges.

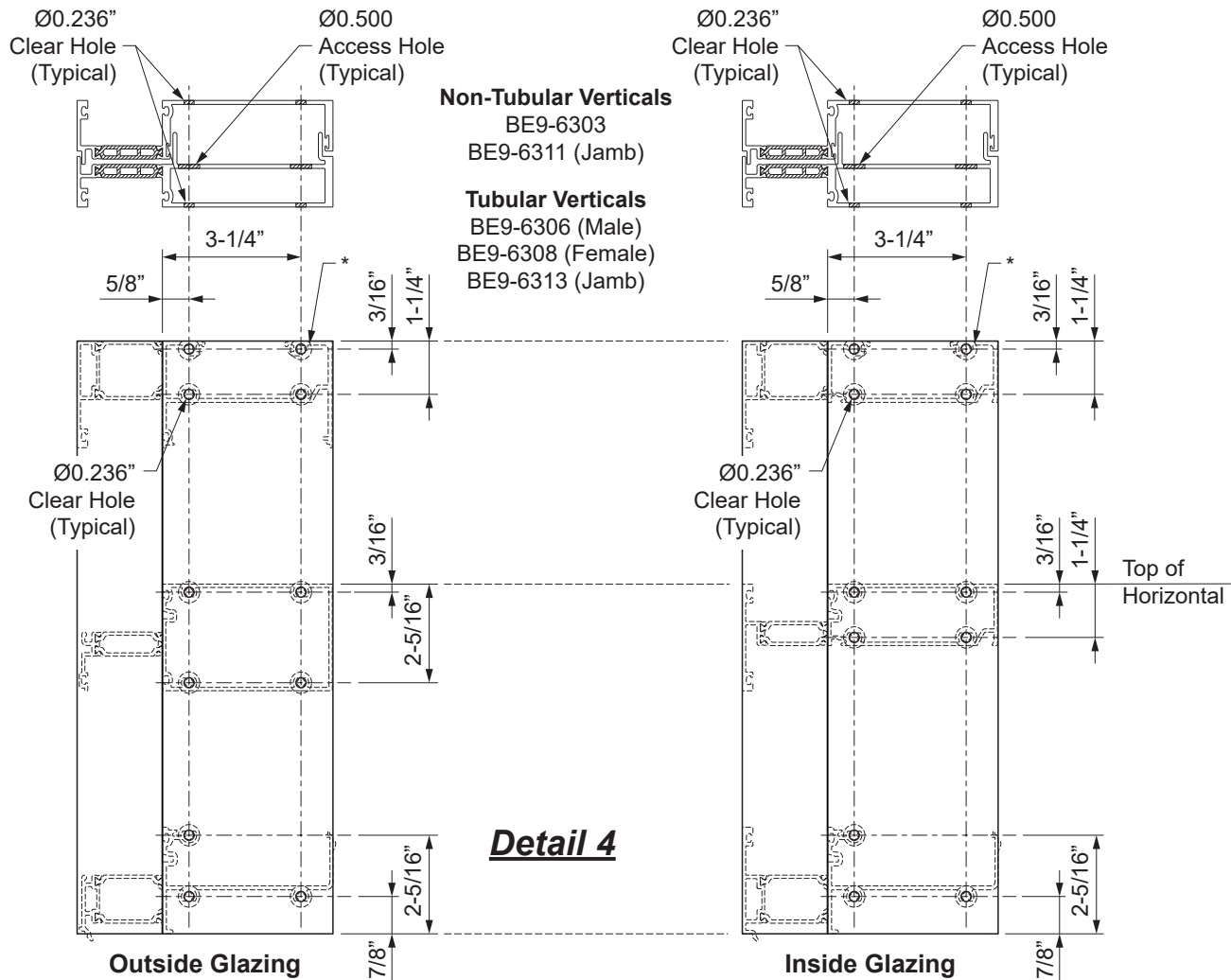

FRAME FABRICATION

STEP 2 (Continued)  
FABRICATE VERTICAL MEMBERS

To fabricate the clear holes for the 90° corner mullion half or 135° corner mullion half, the following procedure is recommended, if you don't have a suitable drill fixture.

- Cut a mitered piece of the head, horizontal, or sill and clamp it onto the mullion where the appropriate horizontal is intended to meet the corner mullion.
- Using a 0.236" drill bit, drill through the screw splines of the mitered piece into the corner mullion. The hole should align with the v-groove in the corner mullion.

See **Detail 5**.

**Note:** For 90° corner mullion, an H-7268 drill fixture can also be used.

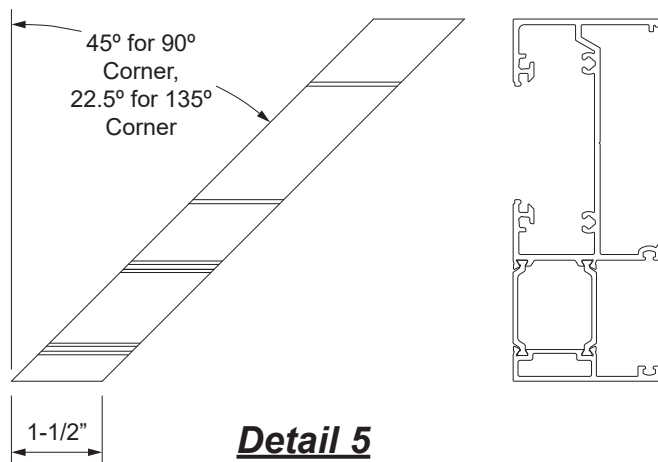

**Detail 5**  
Head Member Shown,  
Horiz. & Sill Similar

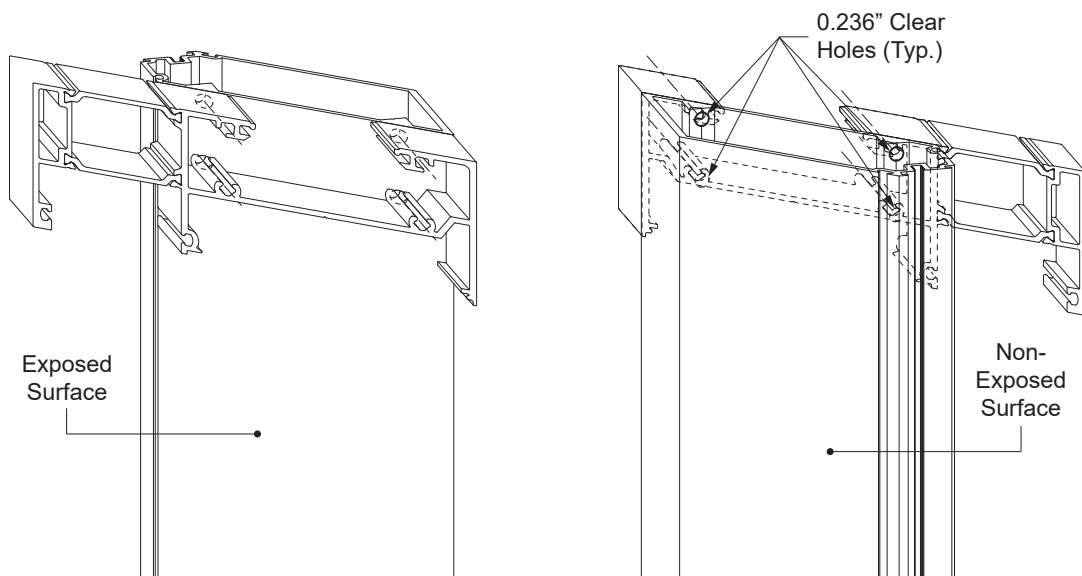

**FRAME FABRICATION**

**STEP 2 (Continued)  
FABRICATE VERTICAL MEMBERS**

-Corner mullion halves also require access holes: 0.500" diameter for the front screw splines, and 0.750" for the rear screw splines as shown in **Detail 6**.

**Notes:** Additional fabrication will be required for the inclusion of steel reinforcing.

\* Tops of mullions with access holes will have sharp edges.

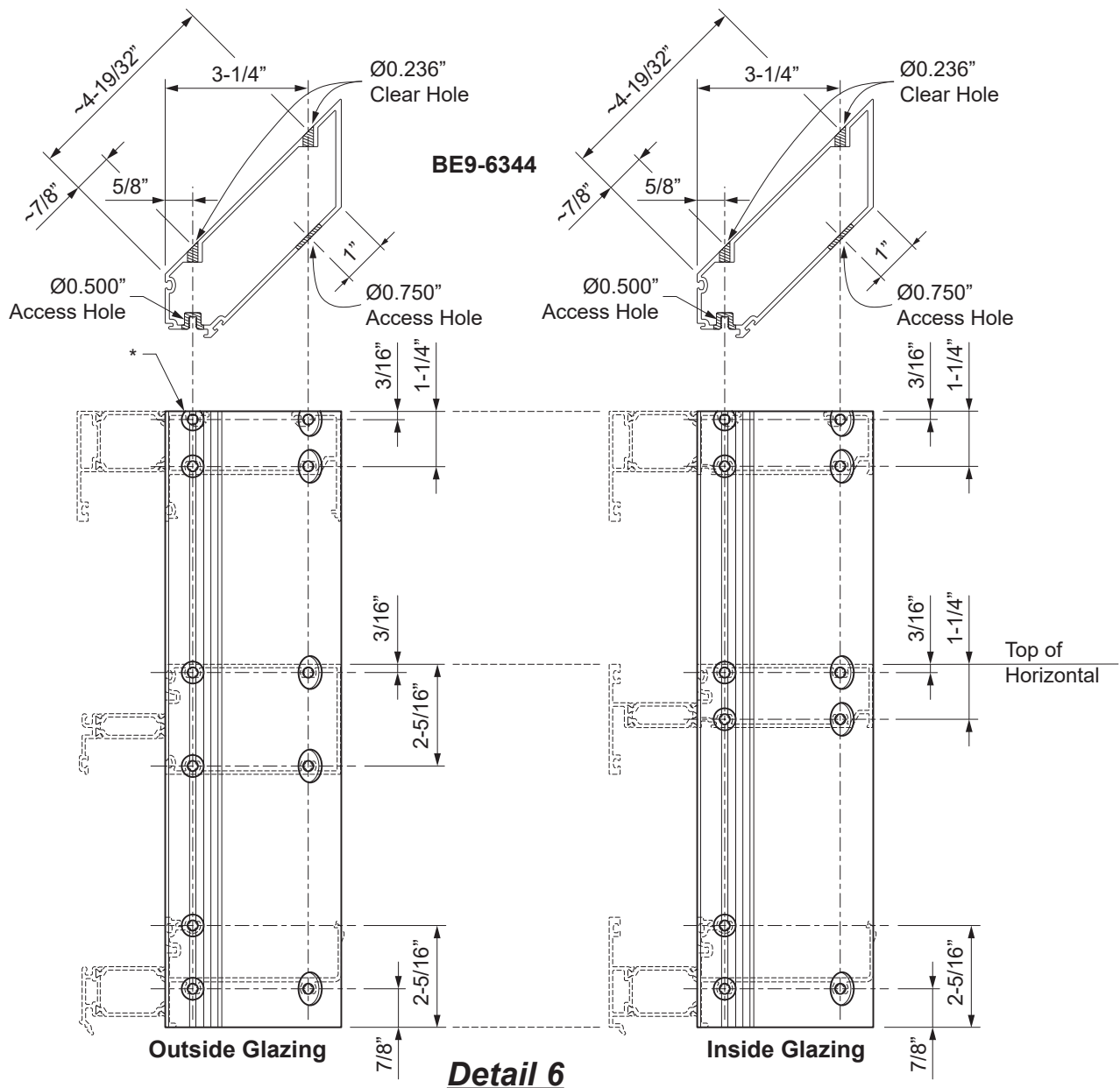

FRAME FABRICATION

STEP 3  
FABRICATE HORIZONTALS

- Cut all horizontals, head, and sill members to the horizontal daylight opening.
- Head and intermediate horizontal members will require 0.189" diameter holes for the glass stops, at 2" from the ends and one at the midpoint, as shown in **Detail 7**.

**Note:** Ø0.189" tap hole for glass stop is 2-5/8" from the end at 90° and 135° corner.

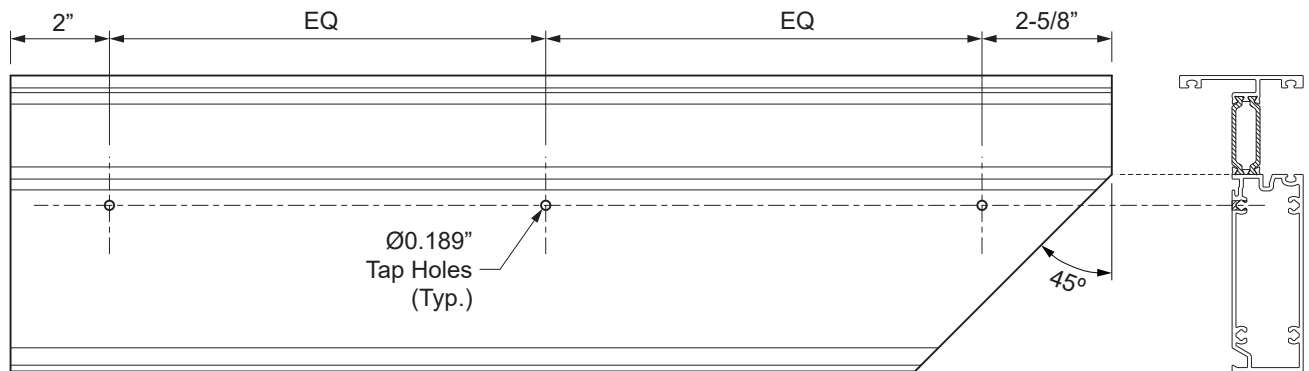
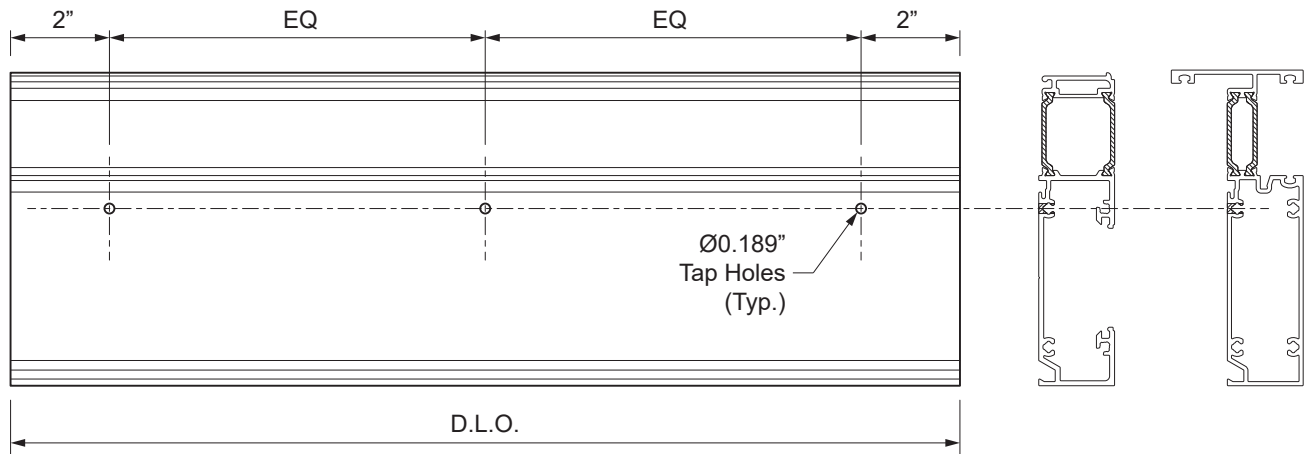

**Detail 7**

**FRAME FABRICATION**

**STEP 3 (Continued)  
FABRICATE HORIZONTALS**

When the head is anchored to the substrate with the E1-2830 anchor, access holes will need to be drilled into the head member.

- Temporarily clamp the E1-2830 anchor onto the head where it will be in relation to the head member once anchored to the substrate.
- Drill 5/16" diameter holes into the head in line with the holes in the anchor. Unclamp the anchor. Then drill the access holes out to 1-1/2" diameter.

**Notes:** This is in addition to the 0.189" diameter tap holes for the glass stop. Refer to approved shop drawings for appropriate fastener and hole locations as determined by a qualified engineer.

See **Detail 8**.

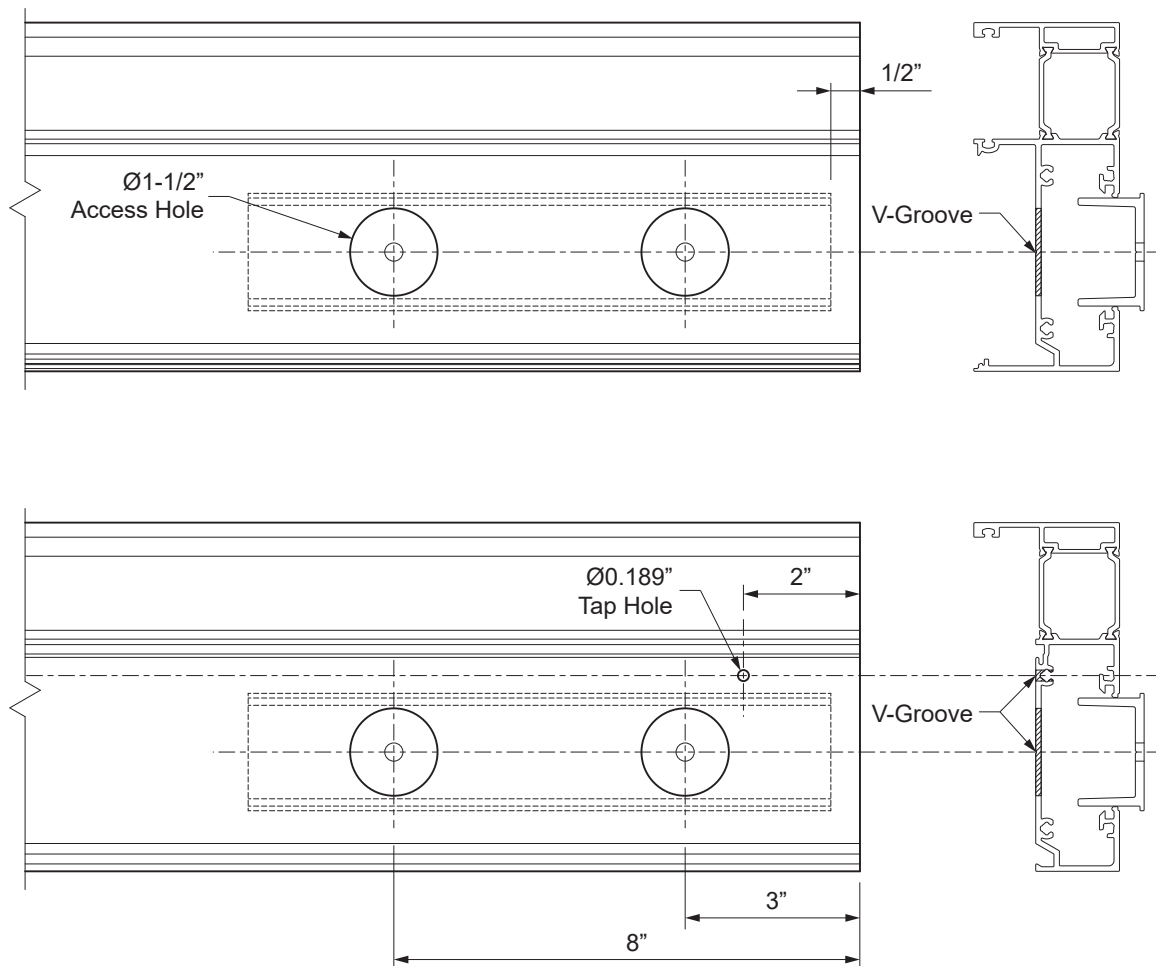

**Detail 8**



FRAME FABRICATION

STEP 4  
FABRICATE FILLERS & GLASS STOPS

-Cut all horizontal flush fillers, flat fillers, and interior covers to horizontal daylight opening minus(-) 1/32". See **Detail 9**.

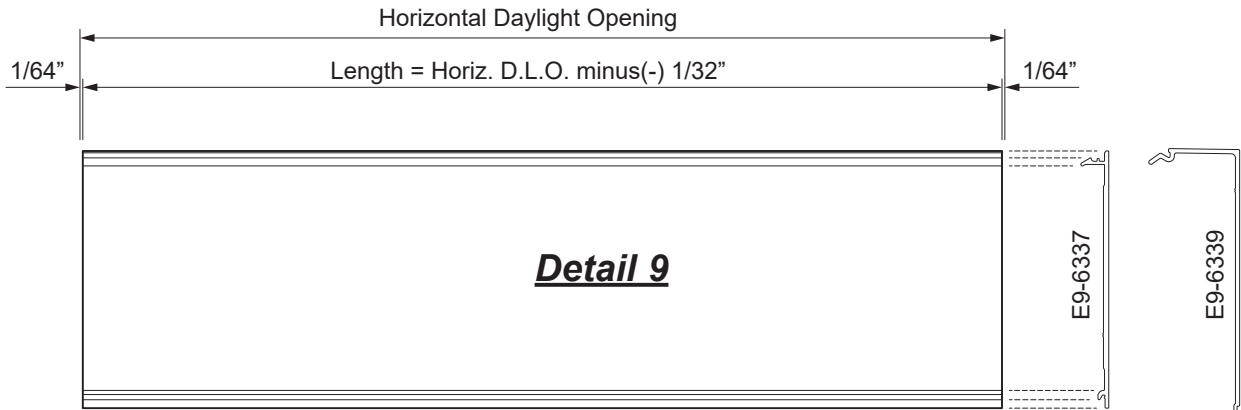

-Cut exterior glass stops to horizontal daylight opening minus(-) 1/16". See **Detail 9A**.

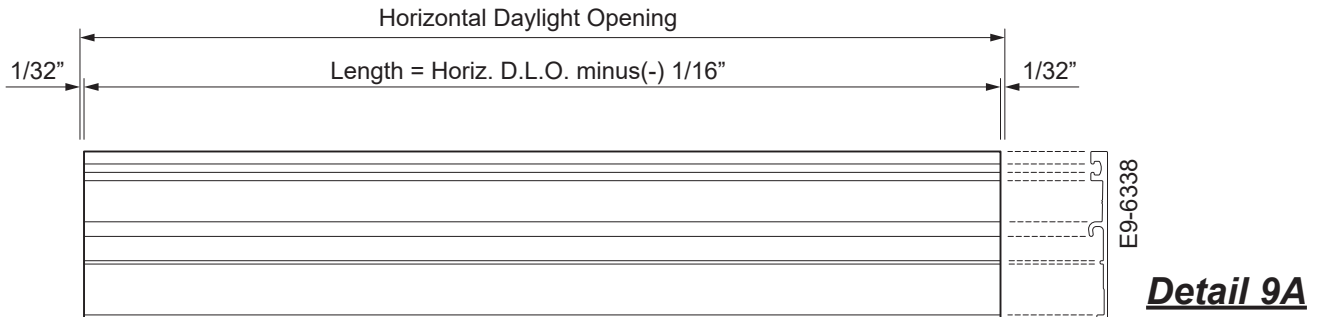

- Cut interior glass stops to horizontal daylight opening minus(-) 1/8".
- For the E9-7852 interior glass stops, drill two Ø0.236" clear holes along the v-groove in the glass stop as shown in **Detail 10**.
- Add a third hole at centerline for glass stops over 48" in length.

**Note:** Ø0.236" clear hole for glass stop is 2-9/16" from the end at 90° and 135° corner.

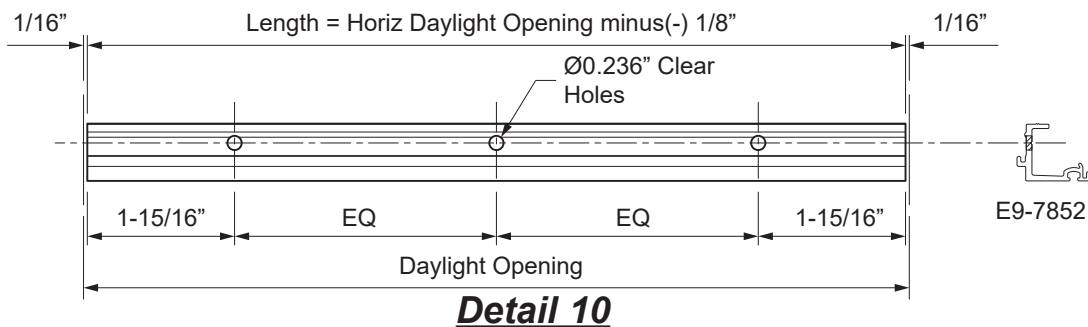

**FRAME FABRICATION**

**STEP 5  
FABRICATE SILL FLASHING & FLASHING FACE COVER**

- Cut the sill flashing to the frame width plus(+) 5/16” at each jamb.
- Cut the E9-6342 flashing face cover to the same dimension as the interior of the flashing.
- For door jambs, allow the sill flashing extend beyond the YWW framing by 1/8”.

**Note:** For additional possibilities such as slab edge cover application, it is recommended to provide additional space between the edge of the sill flashing and the jamb substrate.

- For frame openings longer than 24’-0”, allow for a 3/8” splice joint between sill flashing members every twelve to fifteen feet at the center of a daylight opening.
- Mark the front face of the sill flashing at the center of each vertical location and the midpoint of the daylight opening between the verticals.
- Drill a 5/16” diameter weep hole in the face of the sill flashing at each location marked.
- Drill a Ø0.213” clear hole in the back of the sill flashing at each location marked.

See **Detail 11**.

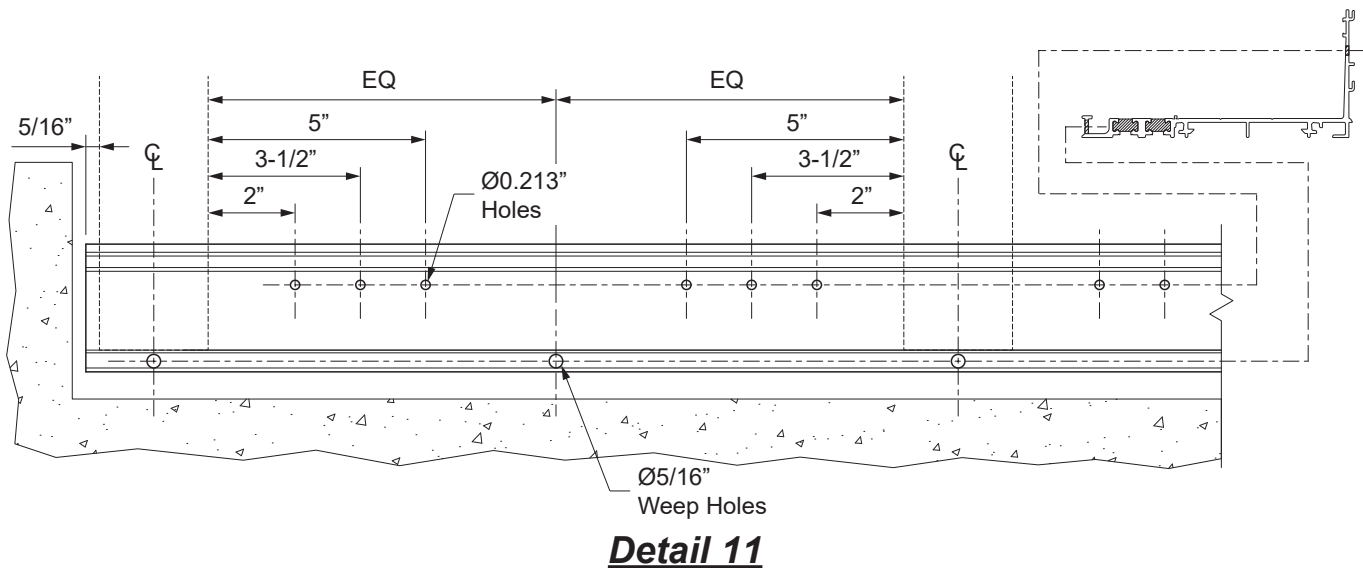

FRAME FABRICATION

**STEP 5A**  
**FABRICATE SLAB EDGE PLATE ADAPTOR**

- Cut the aluminum plate adaptor E9-8222 to the same length as the sill flashing.
- Cut slab edge cover plates to length as indicated on the approved shop drawings.

See **Detail 12**.

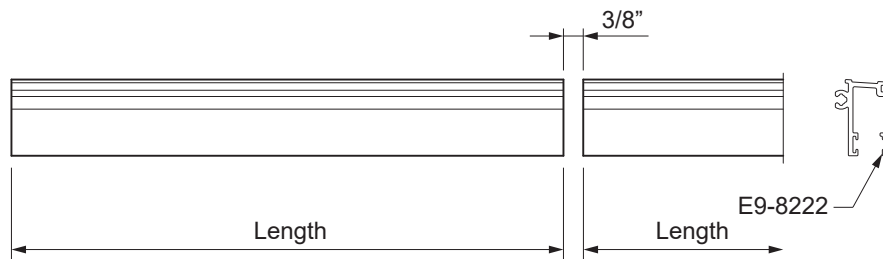

***Detail 12***

**STEP 6**  
**FABRICATE CORNER COVERS**

- Cut the corner cover components to the mullion length. Drill 0.213" diameter holes into the cover at the v-groove where the cover will be fastened to the mullion at 3" from each end and at 9" maximum on center. Avoid drilling where the clear holes in the corner mullion would be.

See **Detail 13**.

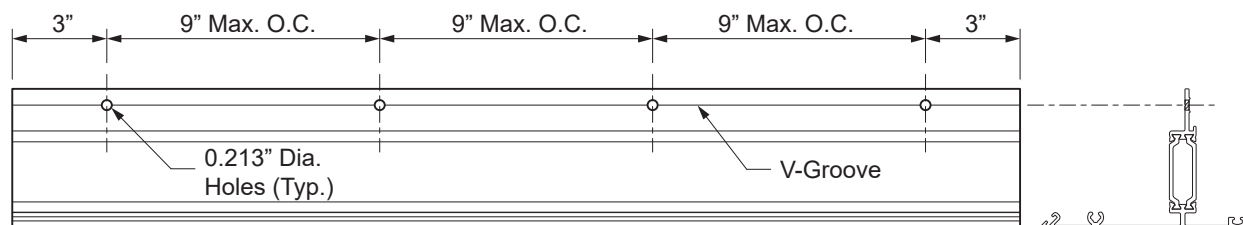

***Detail 13***

BE9-6334 Shown,  
BE9-6336 Similar

**FRAME FABRICATION**

**STEP 7  
FABRICATE HEAD RECEPTOR**

- Cut the head receptor to the frame width plus(+) 5/16” at each jamb.
- Cut the E9-6343 head receptor snap cover to the same dimension as the interior of the head receptor.

**Note:** For additional possibilities such as slab edge cover application, it is recommended to provide additional space between the edge of the head receptor and the jamb substrate.

- For frame openings longer than 24’-0”, allow for a 3/8” splice joint between sill flashing members every twelve to fifteen feet at the center of a D.L.O.
- Mark the front face of the head receptor at the center of each vertical location and the midpoint of the daylight opening between the verticals.
- Drill a 5/16” diameter weep holes in the head receptor at each location marked.
- Drill clear holes for anchor fasteners into the head receptor as indicated on the approved shop drawings and or P.E. calculations.

See **Detail 14**.

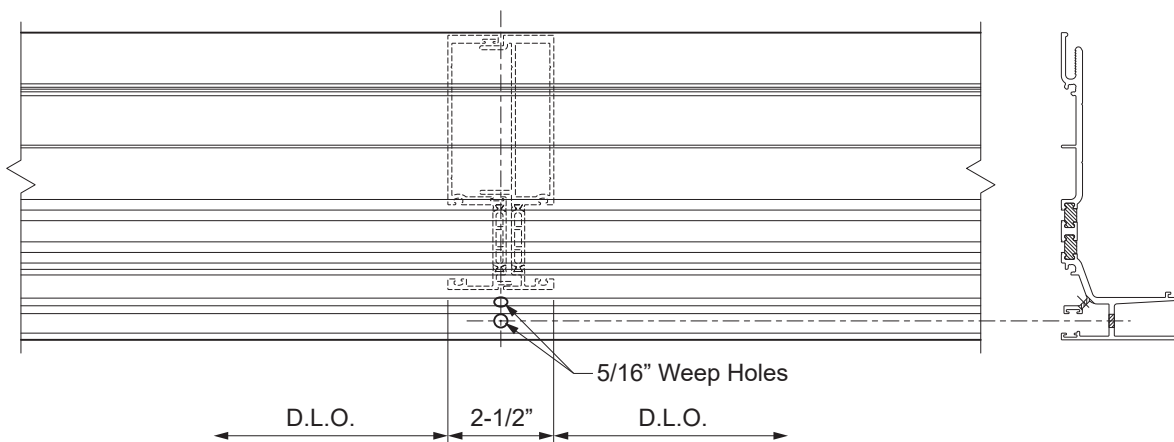

**Detail 14**

FRAME ASSEMBLY

STEP 8  
ASSEMBLE FRAME

**Note:** It is recommended to lay out the unit pieces face up on a table or saw horses during assembly, fully supporting the mullions. If using saw horses, a brace tying the two together will be required.

- Clean all joint surfaces using cleaner approved by sealant manufacturer.
- Apply sealant to the end of the horizontals members to be attached to the first mullion or jamb, at the shaded areas of the head and intermediate horizontals and the entire end of the sill.

See **Detail 15**.

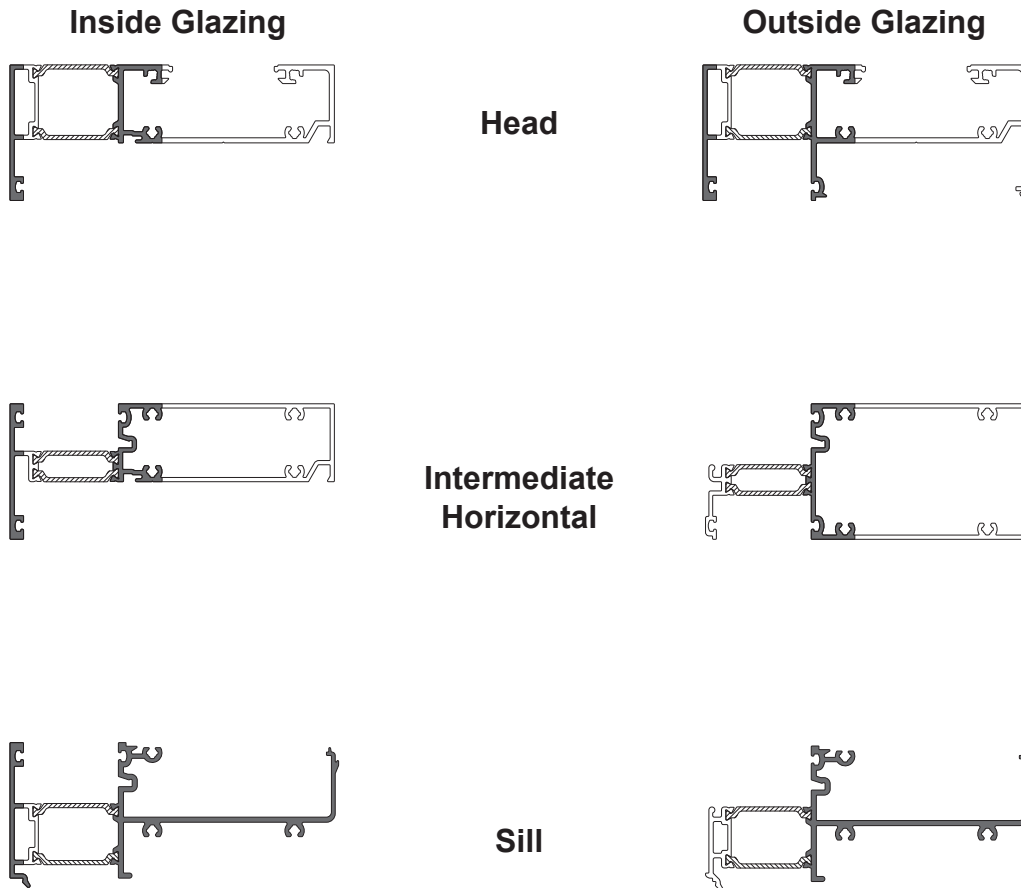

**Detail 15**

**FRAME ASSEMBLY**

**STEP 8 (Continued)  
ASSEMBLE FRAME**

- Attach the horizontal members to the first mullion or jamb using PC-1220 screws, ensuring the bottom and back of the sill aligns with the bottom and back of the mullion as shown in **Detail 16A**.
- At corner mullions, use PC-1228 screws.

See **Detail 16**.

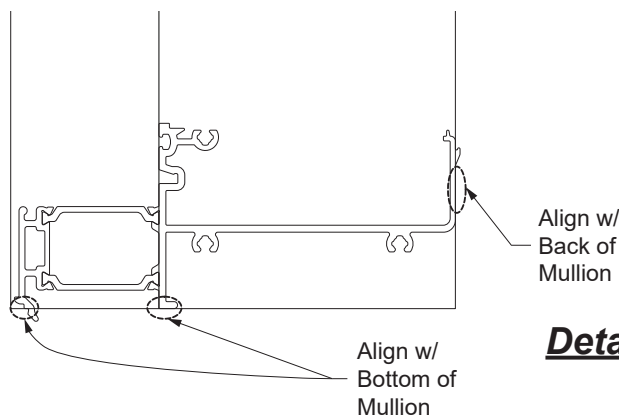
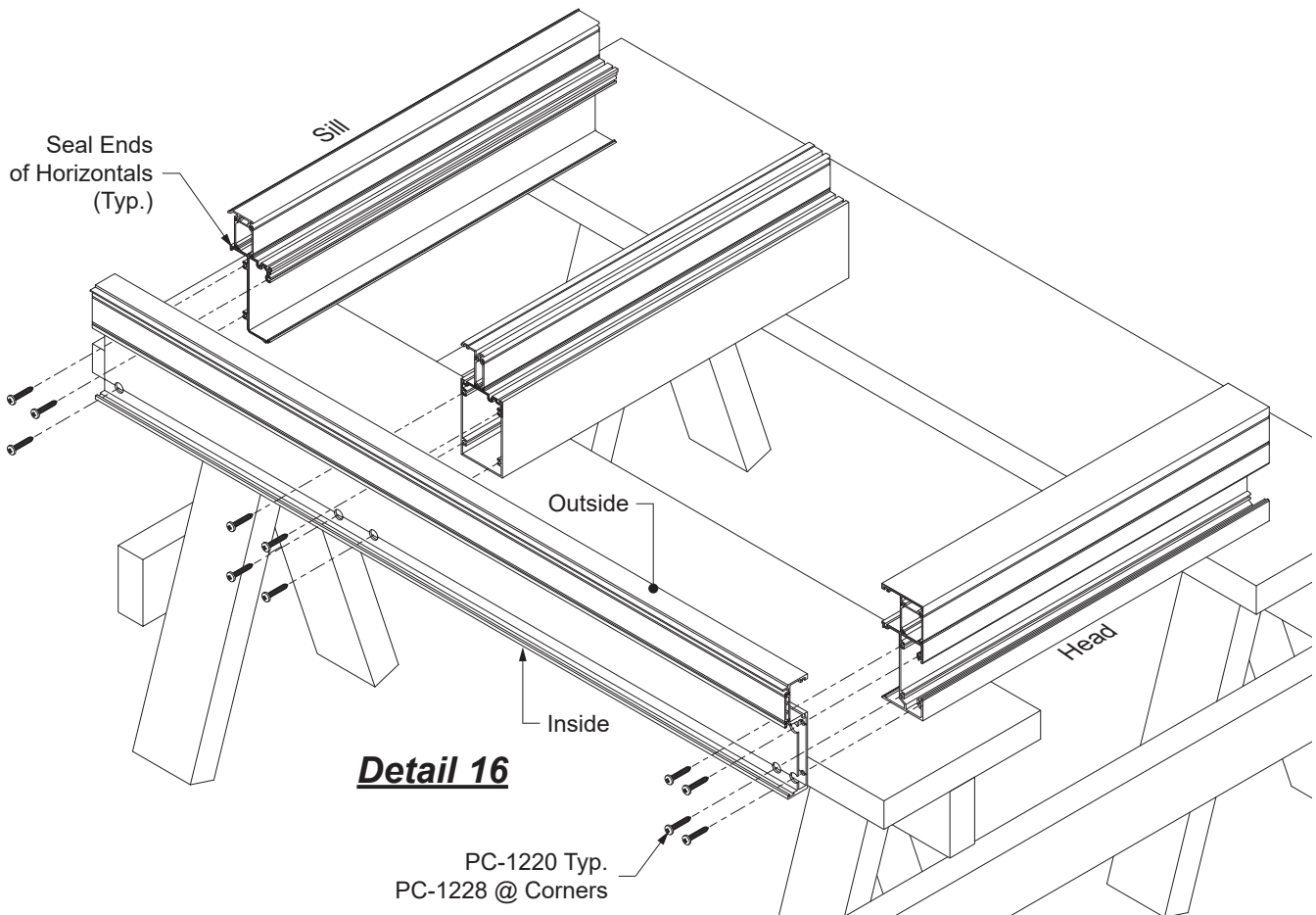

FRAME ASSEMBLY

**STEP 8 (Continued)**  
**ASSEMBLE FRAME**

- Apply sealant to the end of the head, horizontals, and sill that is to be attached to the second mullion or jamb as previously shown in **Detail 15**, also ensuring proper alignment at the bottom of the mullion.
- Attach the horizontal members to the mullion using PC-1220 screws. See **Detail 17**.

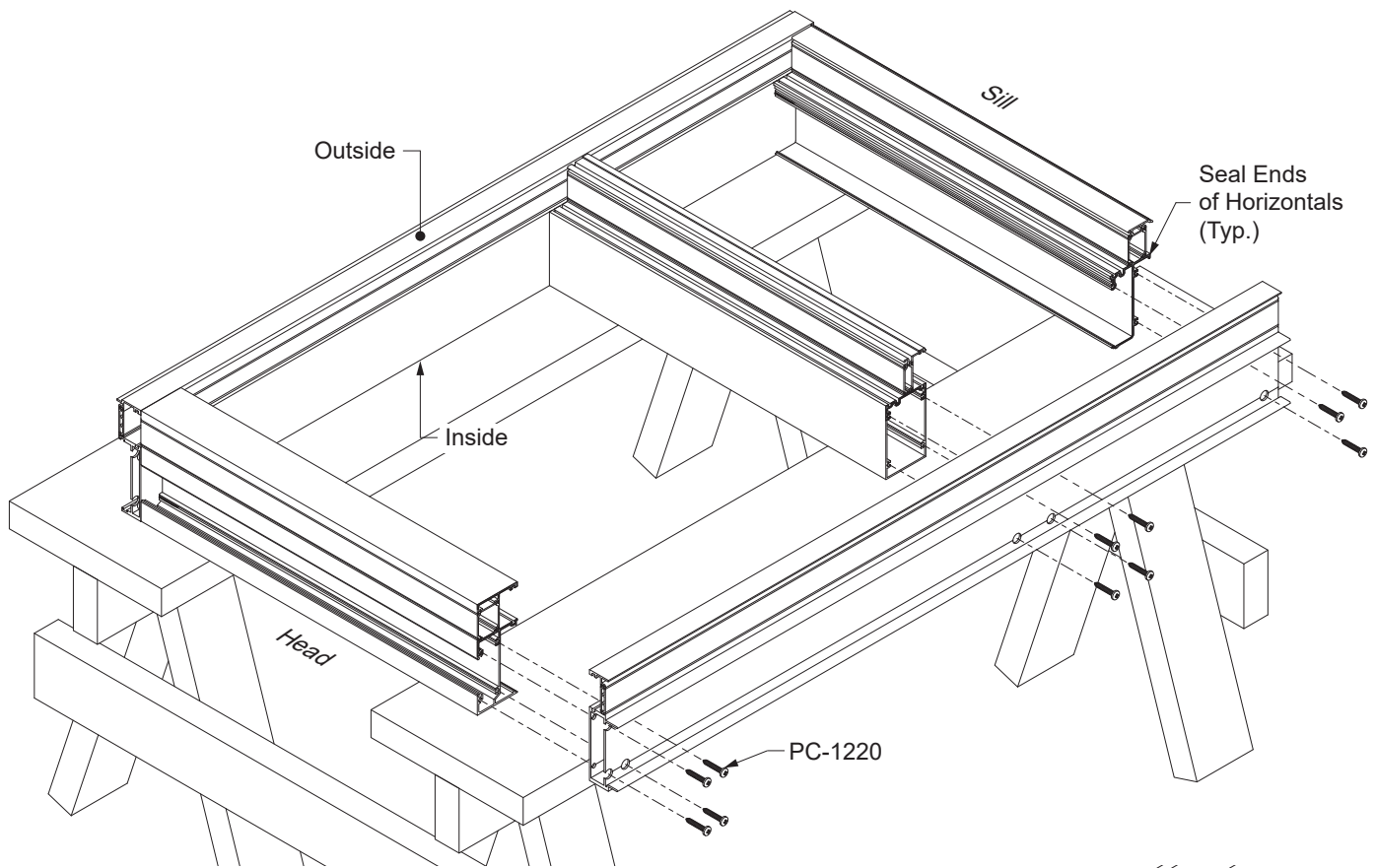

**Detail 17**  
Outside Glazing shown,  
Inside Glazing Similar

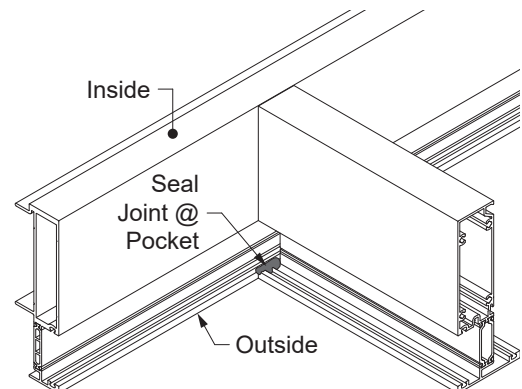

**Detail 17A**  
Inside Glazed  
Units Only

- For inside glazed units, apply sealant to the inside of the glazing pocket of the horizontal at the verticals as shown in **Detail 17A**.

**FRAME ASSEMBLY**

**STEP 8 (Continued)  
ASSEMBLE FRAME (BE9-6318 OPTIONAL HEAD)**

-If BE9-6318 optional head is used, apply continuous sealant across the reglet where the E9-7852 glass stop will hook into. See **Detail 18**.

-Also, apply sealant to the top corners of the mullions where the glass stops will be joined against the verticals.  
-Install the glass stop using PC-1210 screws. See **Detail 19**.

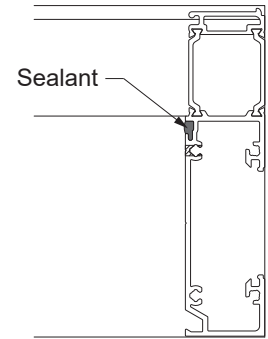

**Detail 18**

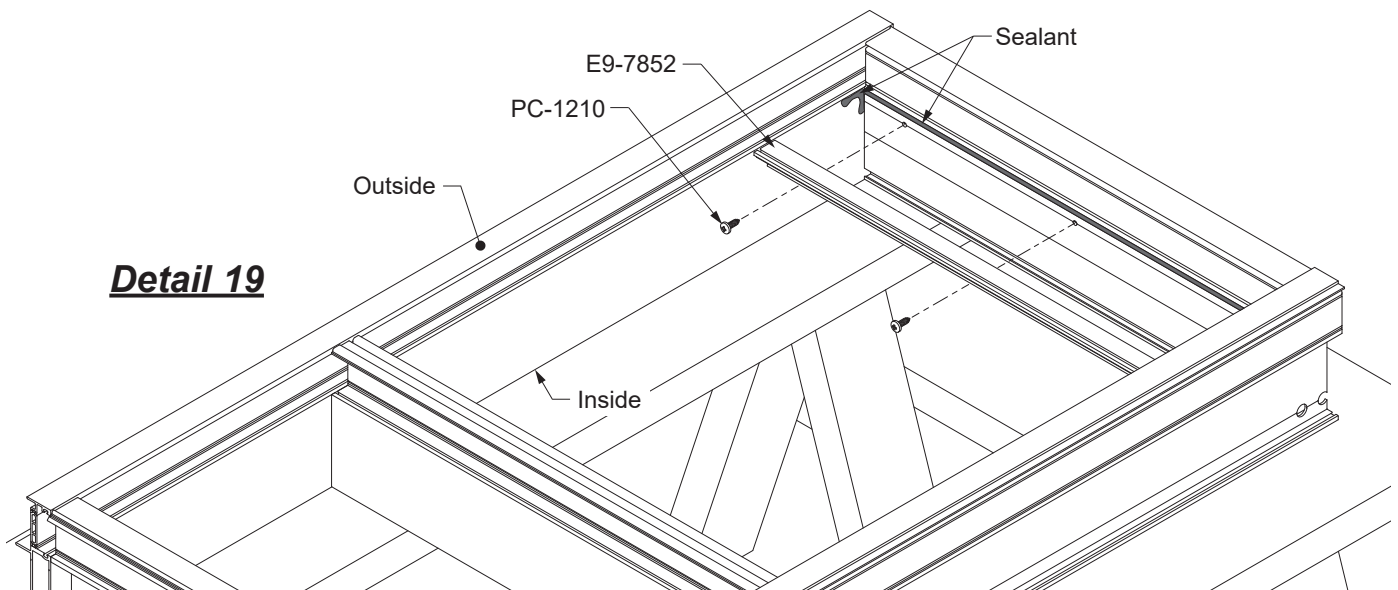

**Detail 19**

-Tool sealant at the interior of the glass stop where it meets the vertical.

See **Detail 20**.

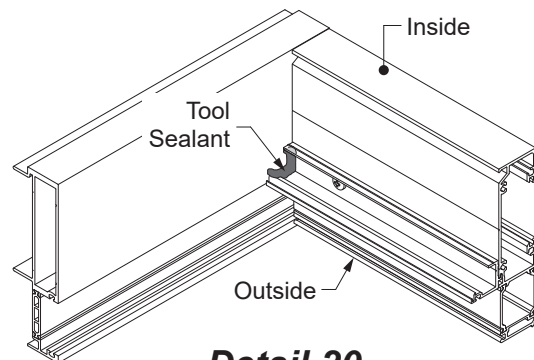

**Detail 20**  
As Shown from  
Underside



## FRAME ASSEMBLY

### STEP 8 (Continued) ASSEMBLE FRAME

-Apply and tool additional sealant to the head and sill as shown in **Details 21 & 22**.

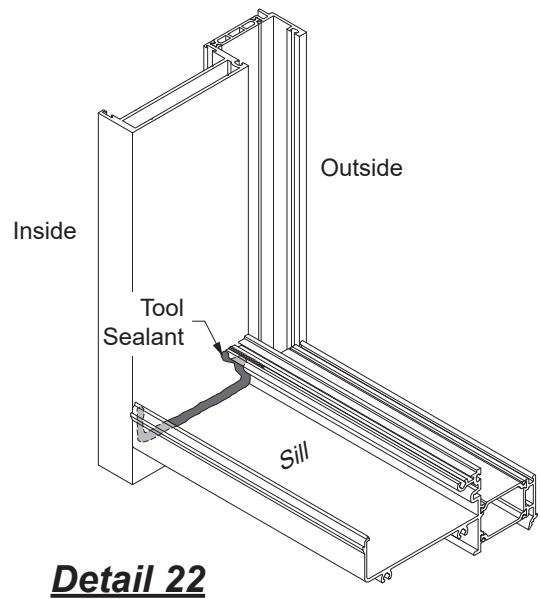
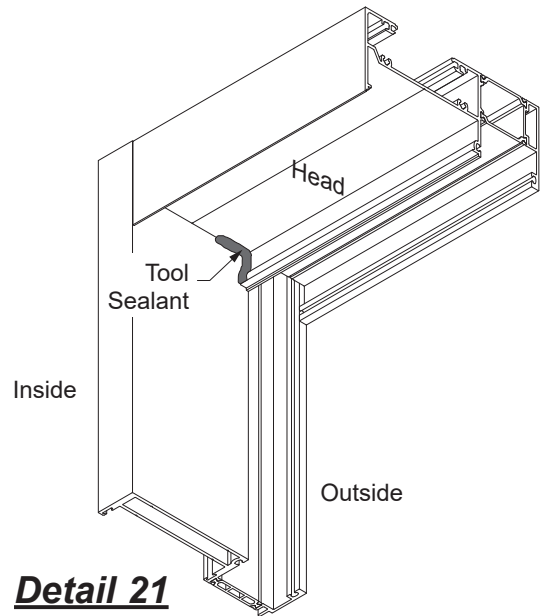

**FRAME ASSEMBLY****STEP 9 (Optional)  
INSTALL STEEL REINFORCING**

- Install steel reinforcing into the mullions and jambs as required by the P.E. calculations and or approved shop drawings.
- Take care that the fasteners do not interfere with the horizontals nor would be visible when the unit is installed.

See **Detail 23**.

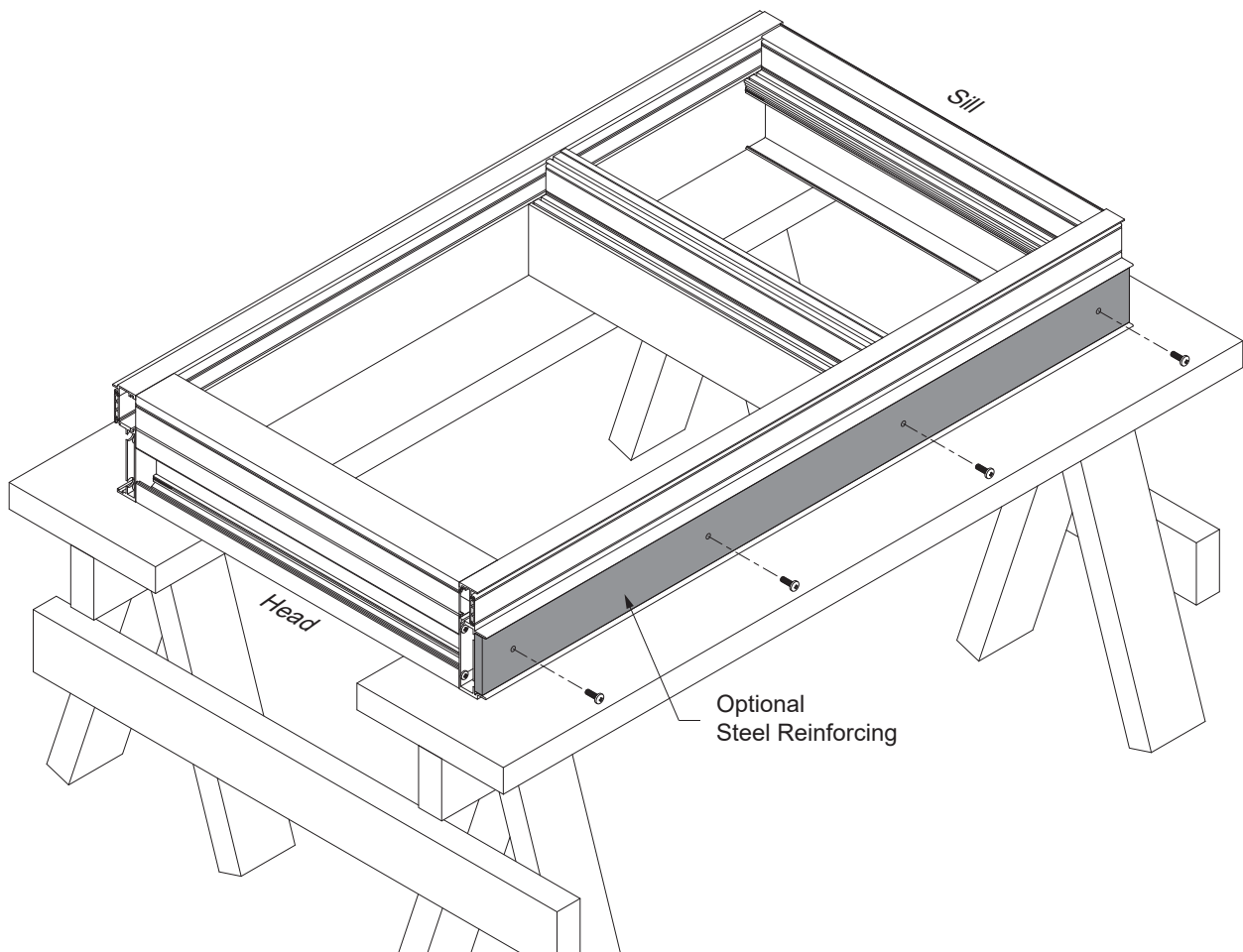

**Detail 23**

FRAME ASSEMBLY

**STEP 10  
INSTALL PERIMETER FILLERS**

For the open back Jamb, BE9-6311, snap on the PVC back jamb filler E3-3667, cut to the length of the jamb mullion, into place as shown in **Detail 24**.

**Note:** Silicone can be added to keep the back jamb filler from sliding out.

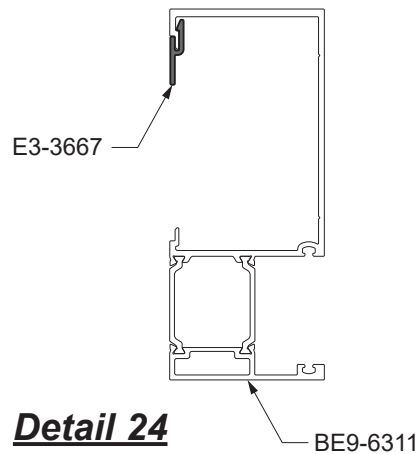

**STEP 11  
INSTALL CORNER COVERS**

For corner mullions, attach the corner covers to the mullion with PM-1006-SS fasteners at the holes previously drilled during fabrication. Also insert E2-0051 bulb gaskets, cut to unit height plus 3", into the corner mullion assembly, leaving the ends to hang out at the top and bottom of the mullion. Apply dabs of sealant to the bottom of the bulb gasket reglets to adhere it to the corner mullion so that it will not slide out during unit installation.

See **Detail 25**.

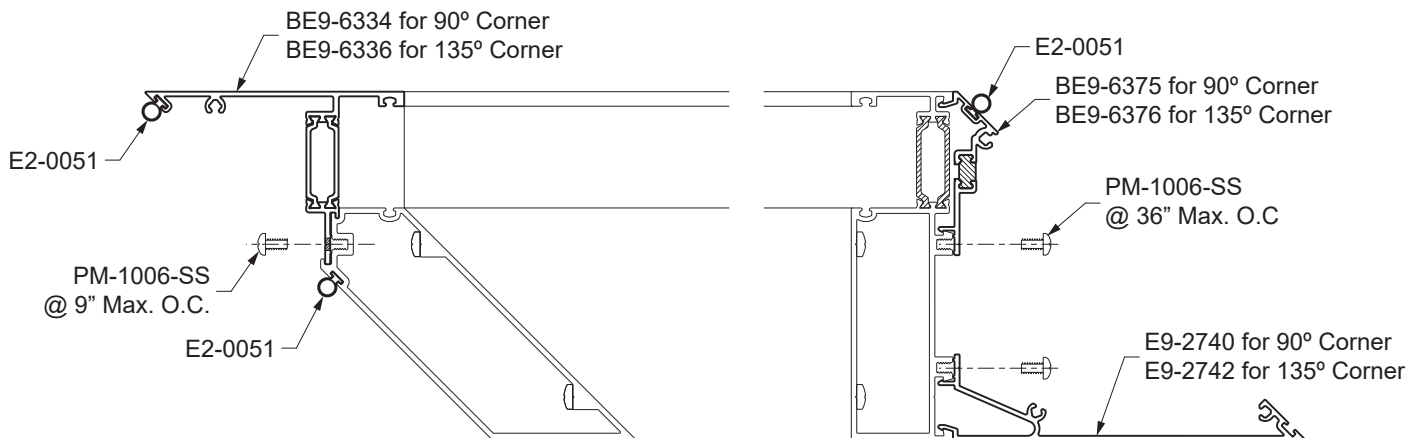

**Detail 25**

**FRAME ASSEMBLY****STEP 12  
INSTALL OUTSIDE CORNER END CAPS**

- Prior to attaching outside corner end caps at the head, trim off the excess bulb gasket.
- Apply sealant to the top of the mullion as shown in **Detail 26A**.

Attach the corner end cap using (2) FC-1006 screws. See **Detail 26B**.

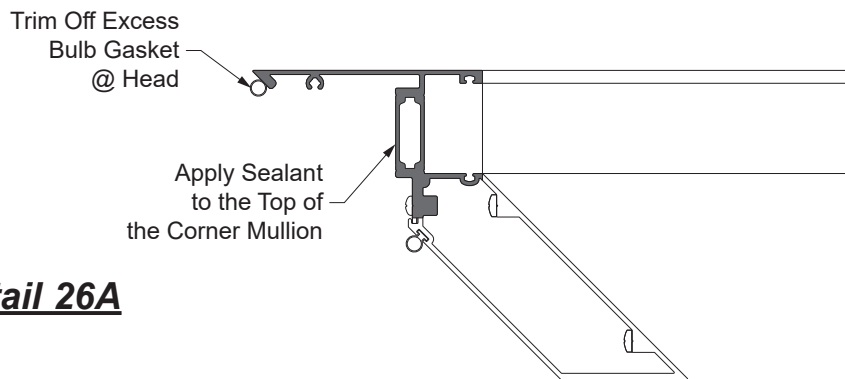
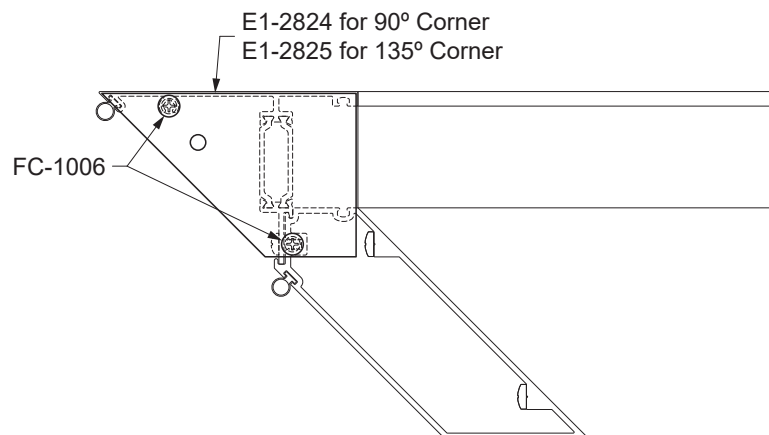
**Detail 26A****Detail 26B**

**Note:** Inside corner members utilize E2-0259 foam backer tape as previously shown on **Page 24**.

## FRAME ASSEMBLY

### STEP 13 INSTALL WEATHER SEAL

Weather seal gaskets (E2-0065) are installed in the female mullion only.

- Cut the weather seal gasket to length of the vertical plus (+) 3", and install into the reglets of the female mullion in the proper orientation as shown in **Detail 28**.
- Apply dabs of sealant to the bottom of the weather seal gasket to adhere it to the mullion so that it will not slide out during unit installation. Do not overseal. Too much silicone will deter mullion engagement.
- Trim the gasket after shrinkage.

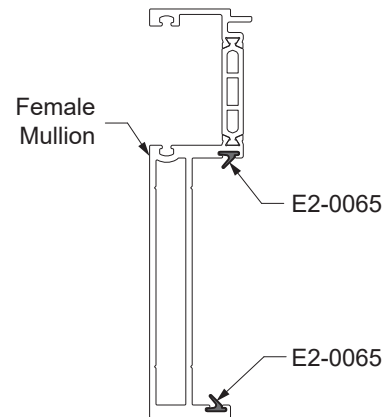

**Detail 27**

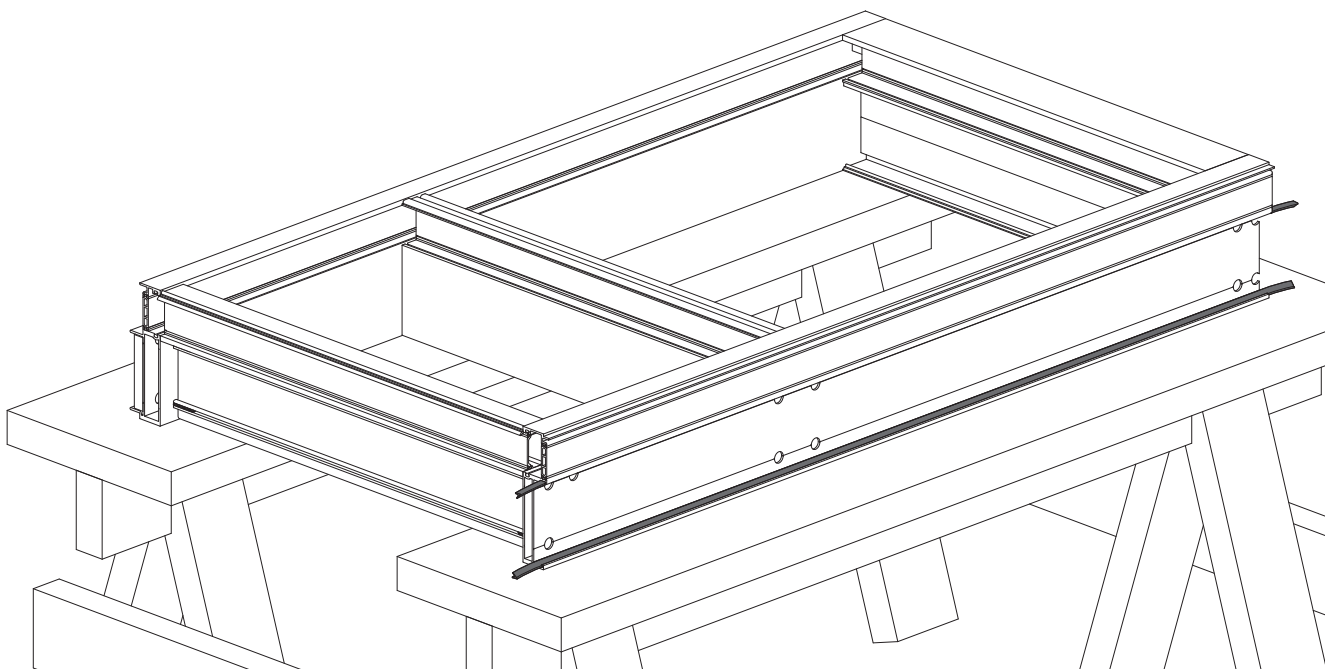

**FRAME ASSEMBLY**

**STEP 14 (Optional, Not Necessary with Head Receptor Applications)  
INSTALL FOAM PLUGS AT HEAD**

- Cut E2-0259 foam backer tape (maximum 1-1/4" long) to be installed at the head only. These will act as end caps for perimeter backer rods and sealant.
- Peel the adhesive tape from the foam and adhere it to the mullion as shown in **Detail 26**. The foam can be easily compressed around physical obstacles in the assembled verticals.
- In the case where steel reinforcing is present at the head, the foam plugs may be adhered to the steel.
- Fill the cavities at the front of the mullion with sealant.

**Notes:** For best adhesion, make sure the contact surfaces of the verticals and or steel members are clean and dry.  
Also, take care to ensure the interior foam plug does not interfere with mullion engagement.

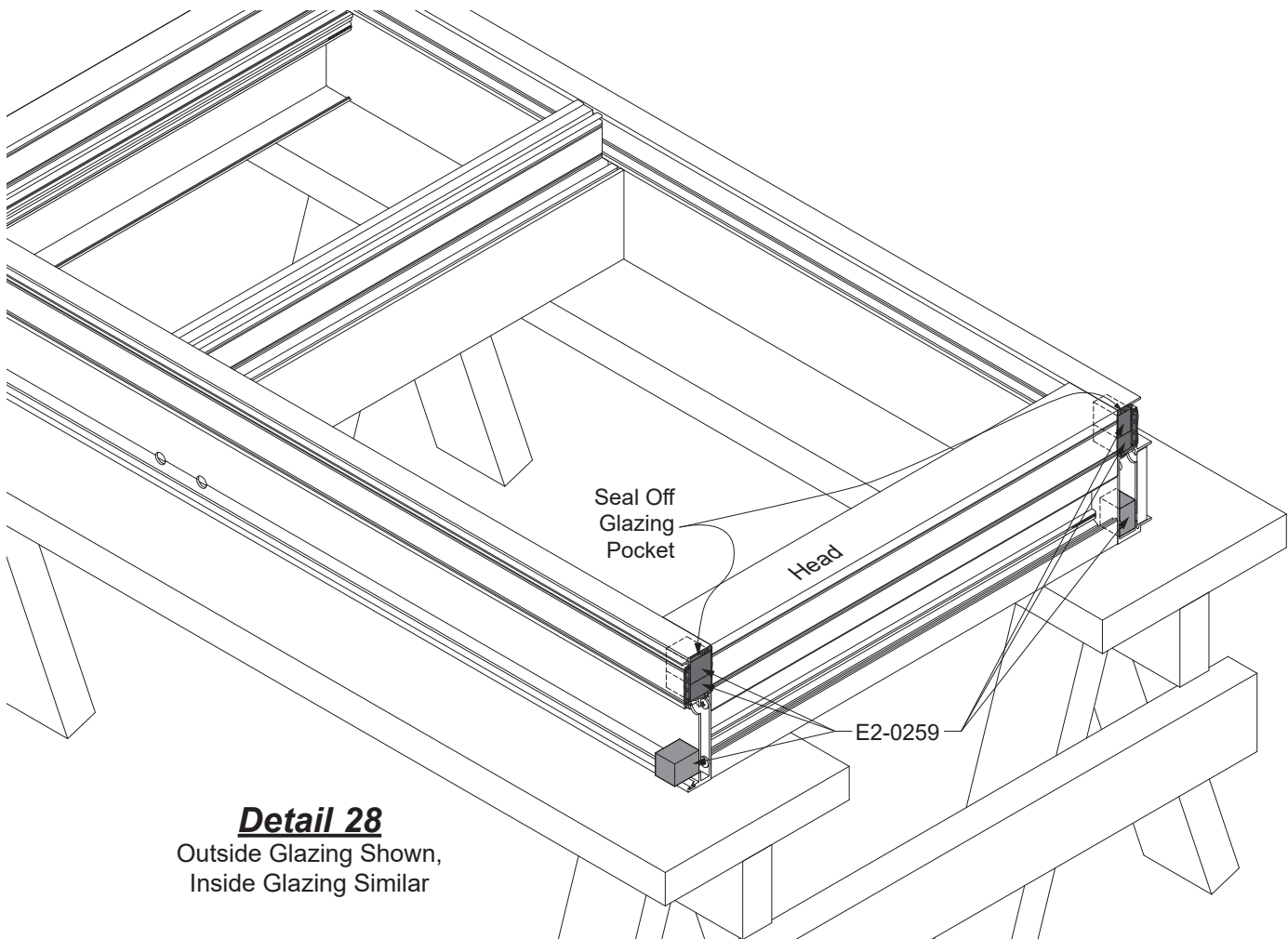

## FRAME ASSEMBLY

### STEP 15 INSTALL WATER DEFLECTOR

YWW 60 XT requires the installation of a water deflector, E2-0049, at the ends of every intermediate horizontal to keep water off of the insulating glass units.

-Peel away the protective paper from the bottom of the water deflector, E2-0049, and install the water deflector at the ends of each horizontal.

See **Detail 29**.

-Position the vertical leg of the water deflector against the end of the horizontal.

**Note:** For best adhesion, make sure that the horizontal is clean and dry.

-Apply and tool sealant along the edges of the deflector and down onto the horizontal. Seal the ramp of the water deflector to the glazing pocket, filling the gap at the thermal isolator as shown.

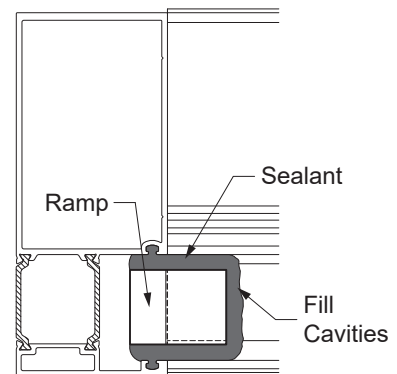

### **Detail 29**

Jamb Mullion shown,  
Others Similar

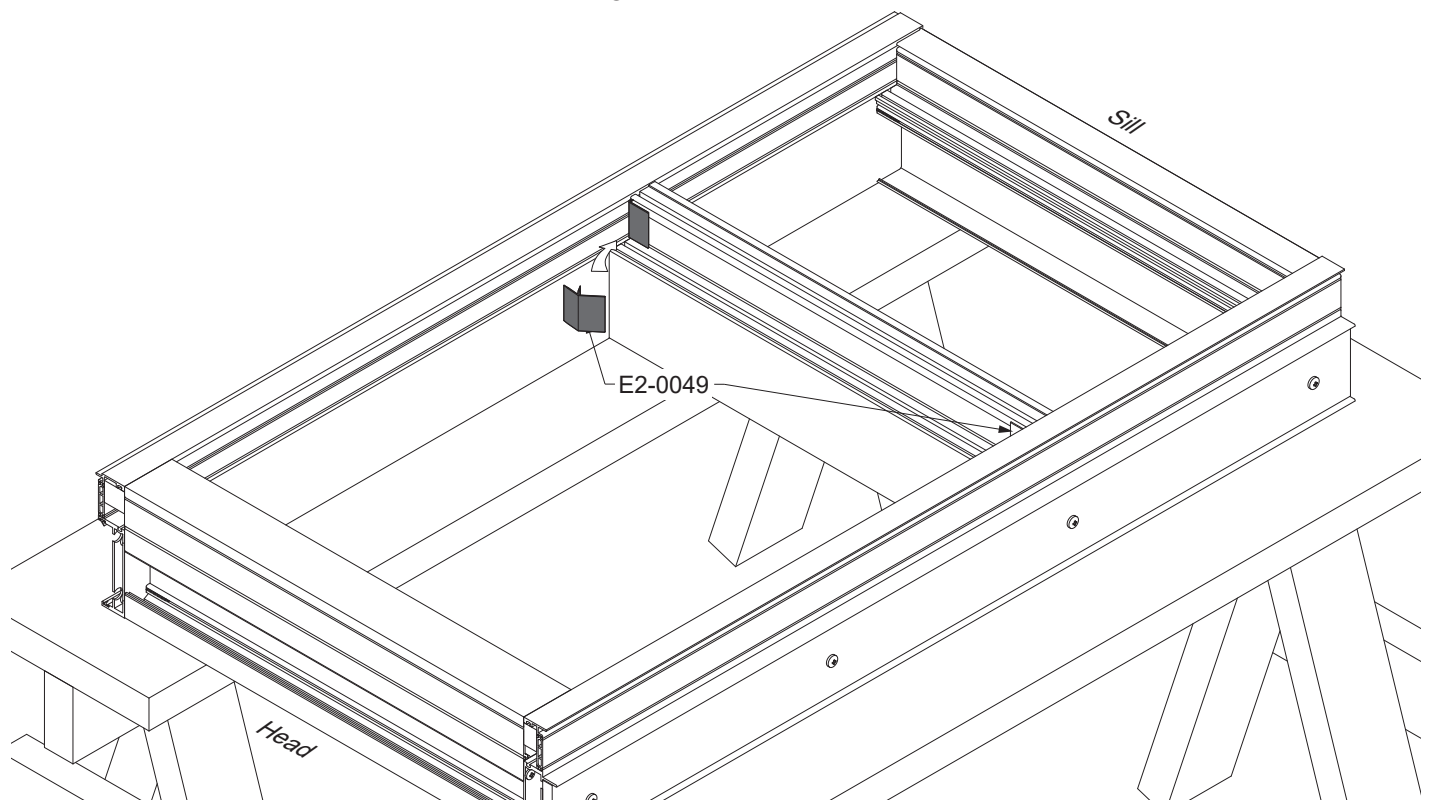

**FRAME ASSEMBLY**

**STEP 16  
INSTALL DART GASKETS**

-Using a small brush, clean out any debris that may have accumulated in the gasket reglets.

**Vertical glazing gaskets must be installed first:**

- Cut vertical dart gaskets to the Daylight Opening plus(+) 3/4" plus(+) an additional 1/4" for each foot of length.  
Notch the ends of the vertical gasket as shown.
- Insert the gasket into the reglets at each end first; then insert the gasket at the midpoint of the opening.
- Push the gasket into the reglet starting at the ends and work towards the midpoint.

See **Detail 30**.

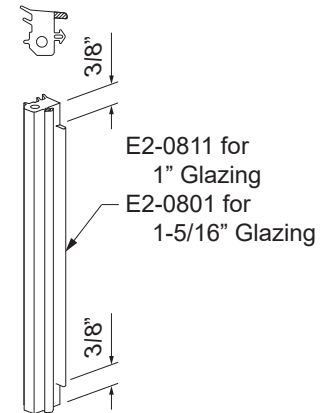

**Detail 30**  
Outside Glazing  
Shown, Inside  
Glazing Similar

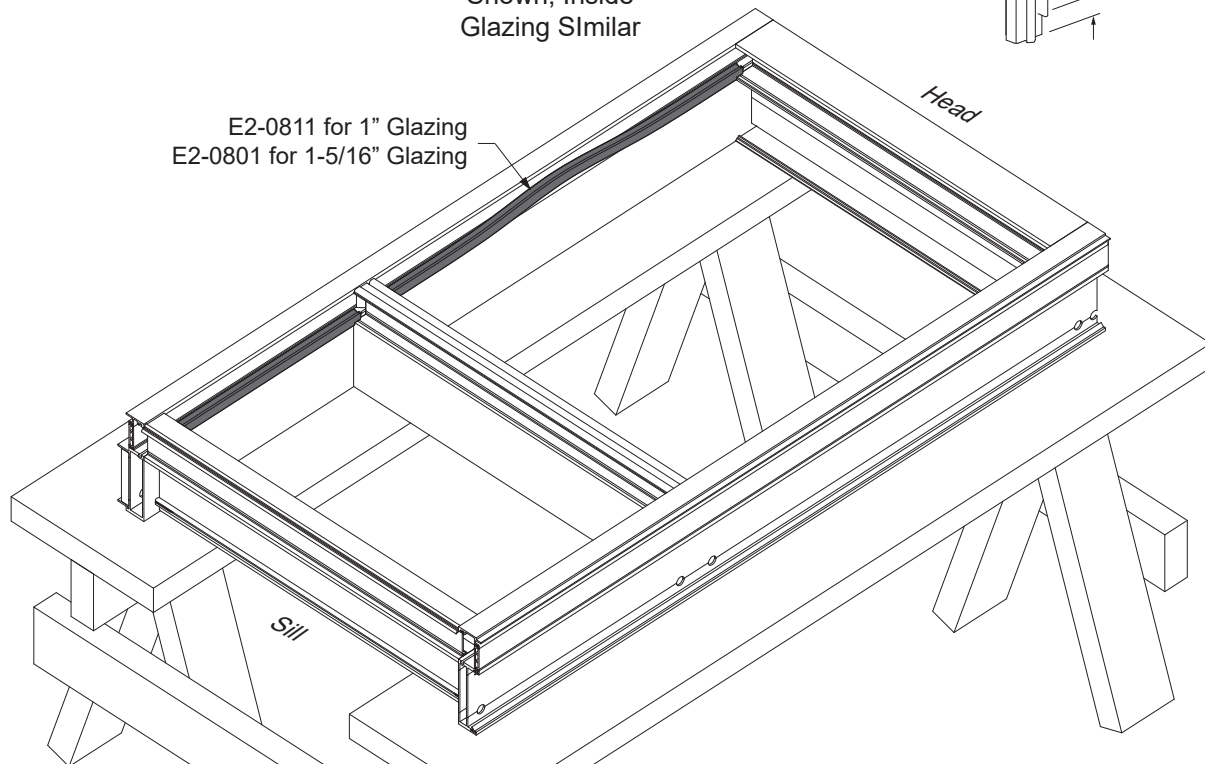



## FRAME ASSEMBLY

### STEP 16 (Continued) INSTALL DART GASKETS

#### Install horizontal glazing gaskets next:

- Cut horizontal glazing gaskets to Daylight Opening plus(+) 1/4" for each foot of length.
- Apply sealant to each end of the horizontal glazing gasket prior to inserting into the reglet.
- Insert the gasket into the reglet at each end first; then insert the gasket at the midpoint of the opening.
- Push the gasket into the reglet starting at each end and work towards the midpoint.
- Tool the excess sealant at the gasket corners to ensure a watertight seal.

See **Detail 31**.

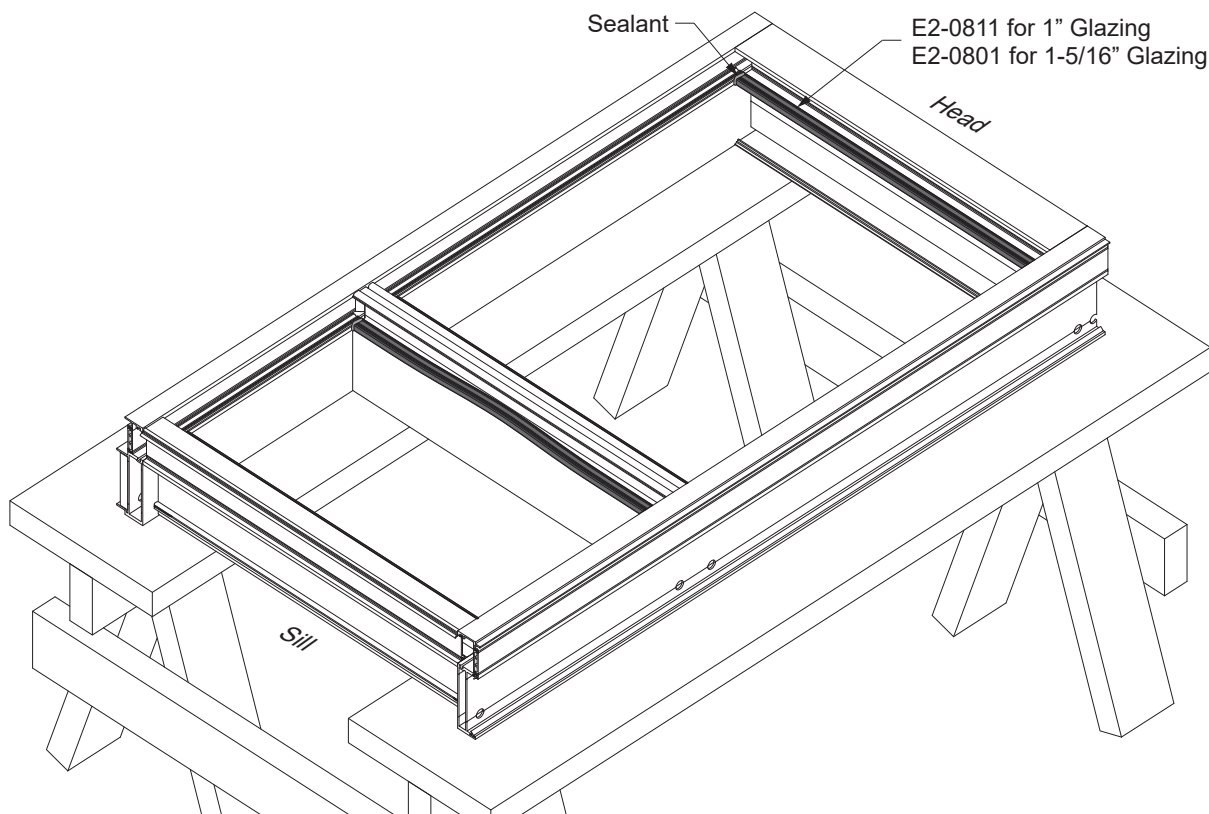

**Detail 31**  
Outside Glazing  
Shown, Inside  
Glazing Similar

**GLAZING**

**STEP 17A  
INSTALL SETTING / SIDE BLOCKS (INSIDE GLAZING)**

-Apply setting blocks into the glazing pockets for every intermediate horizontal as shown in **Detail 32A** at quarter points at every daylight opening. Adhere the sill setting blocks with sealant.

-Apply E2-0133 to every male mullion (shallow pocket).

-Adhere the E2-0020 side blocks to the female mullion for units with a corner mullion for side shipping.

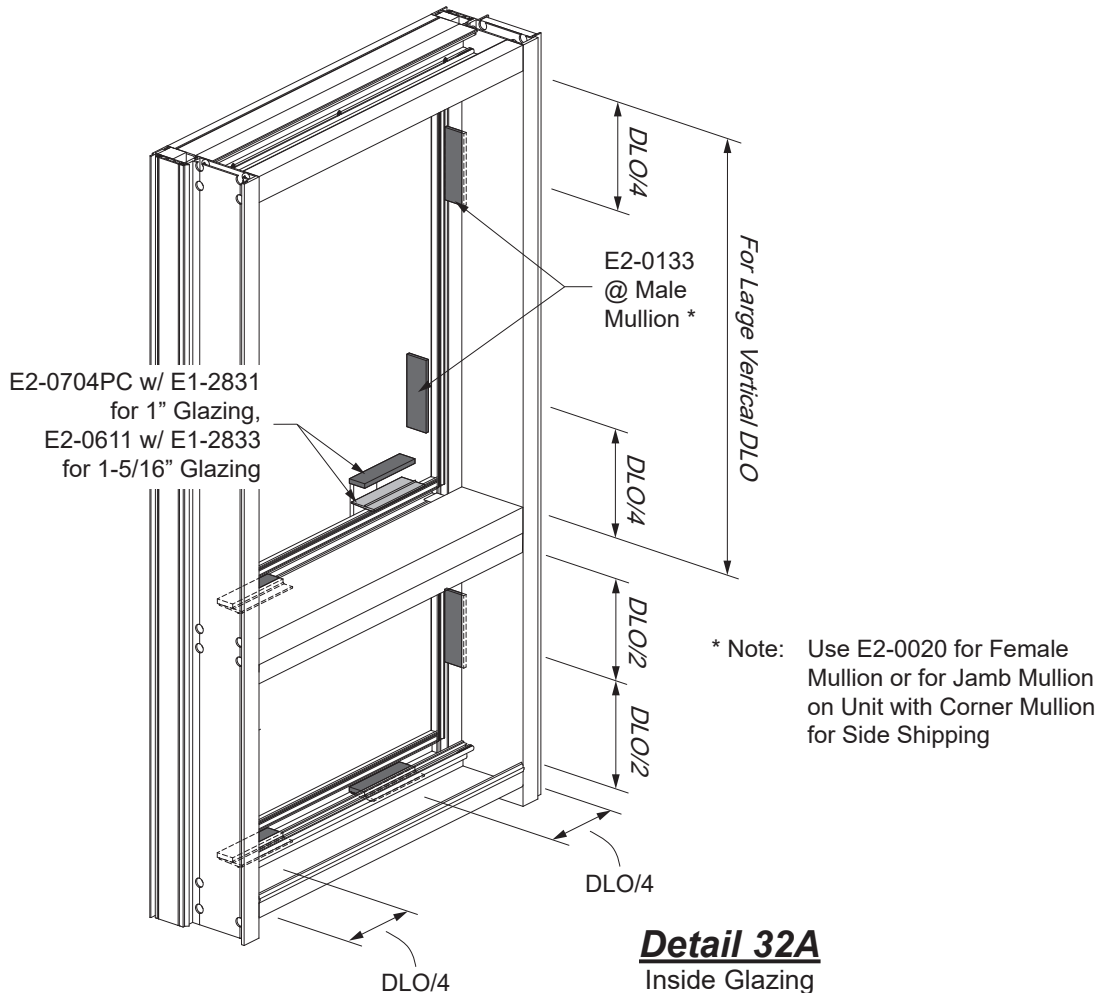

**Packing/Shipping Notes:**

If packing units horizontally, set units with shallow pocket (male mullion side) down. Also on conditions without a shallow pocket (male mullion), use a setting block E2-0020 on one side only and ship with that side down. Ship with corner mullion up if possible. See **Page 41** for application of “This Side Down” label.

GLAZING

**STEP 17B**  
**INSTALL SETTING / SIDE BLOCKS (OUTSIDE GLAZING)**

-Apply setting blocks into the glazing pockets for the uppermost intermediate horizontal as shown in **Detail 32B** at quarter points at every daylight opening. Adhere the setting blocks with sealant.

**Note:** Do not apply setting blocks to the sill member nor the other intermediate horizontals at this point.

- Apply E2-0133 to every male mullion (shallow pocket) and E2-0704PC to the underside of every intermediate horizontal at each end of the daylight opening.
- Adhere the E2-0068 side blocks to the head members with sealant.
- Adhere the E2-0020 side blocks to the female mullion for units with a jamb or corner mullion for side shipping.

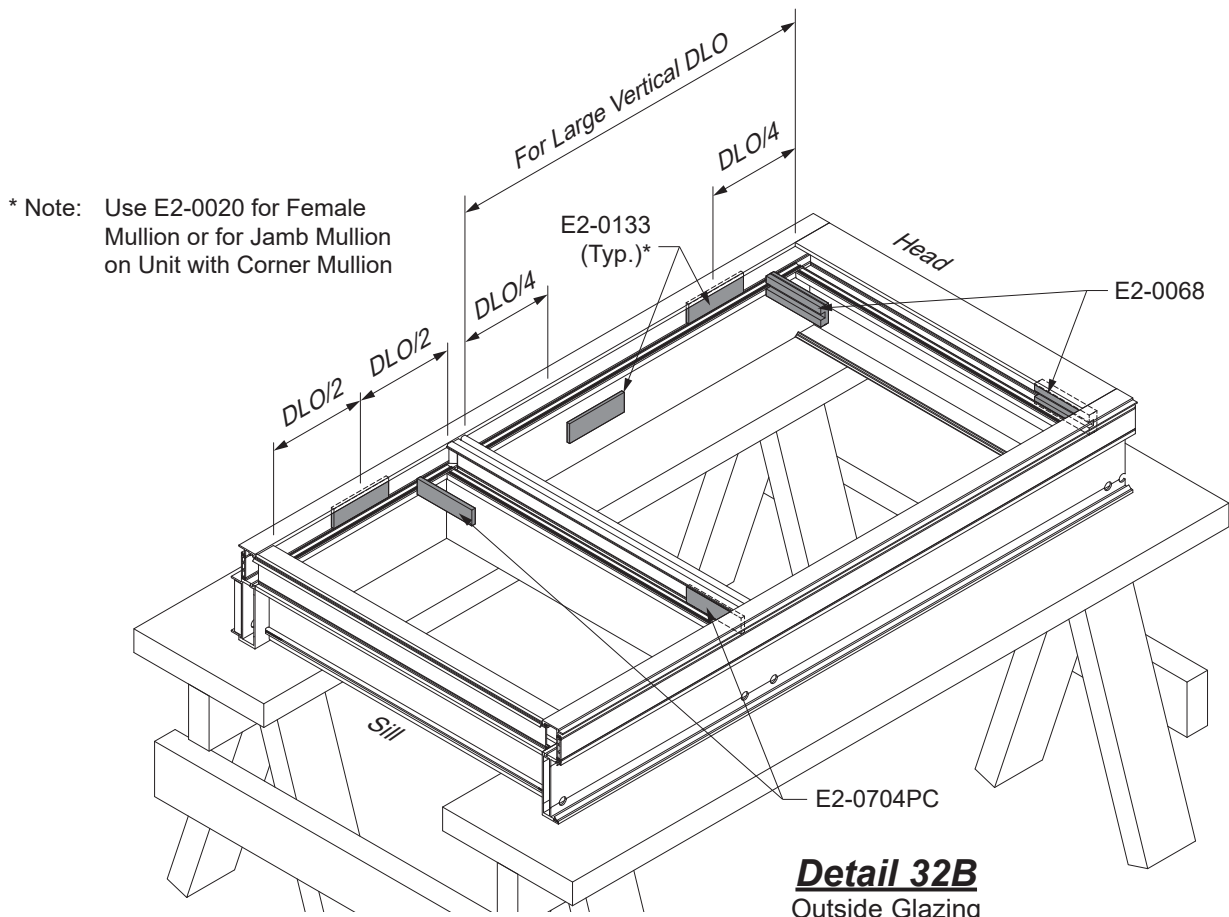

**Packing/Shipping Notes:**

If packing units horizontally, set units with shallow pocket (male mullion side) down. Also on conditions without a shallow pocket (male mullion), use a setting block E2-0020 on one side only and ship with that side down. Ship with corner mullion up if possible. See **Page 41** for application of “This Side Down” label.

**GLAZING**

**STEP 18  
INSTALL GLASS**

Determine the glass size:

	Width	Height
Standard Glazing	D.L.O. + 7/8"	D.L.O. + 7/8"

-Install the glass lites into the daylight openings. Bring the glass lites into the deep glazing pocket first. Then move the glass lites to their proper positions ensuring a 7/16" glass bite all around and tight against the setting and side blocks.

See **Details 33 & 34.**

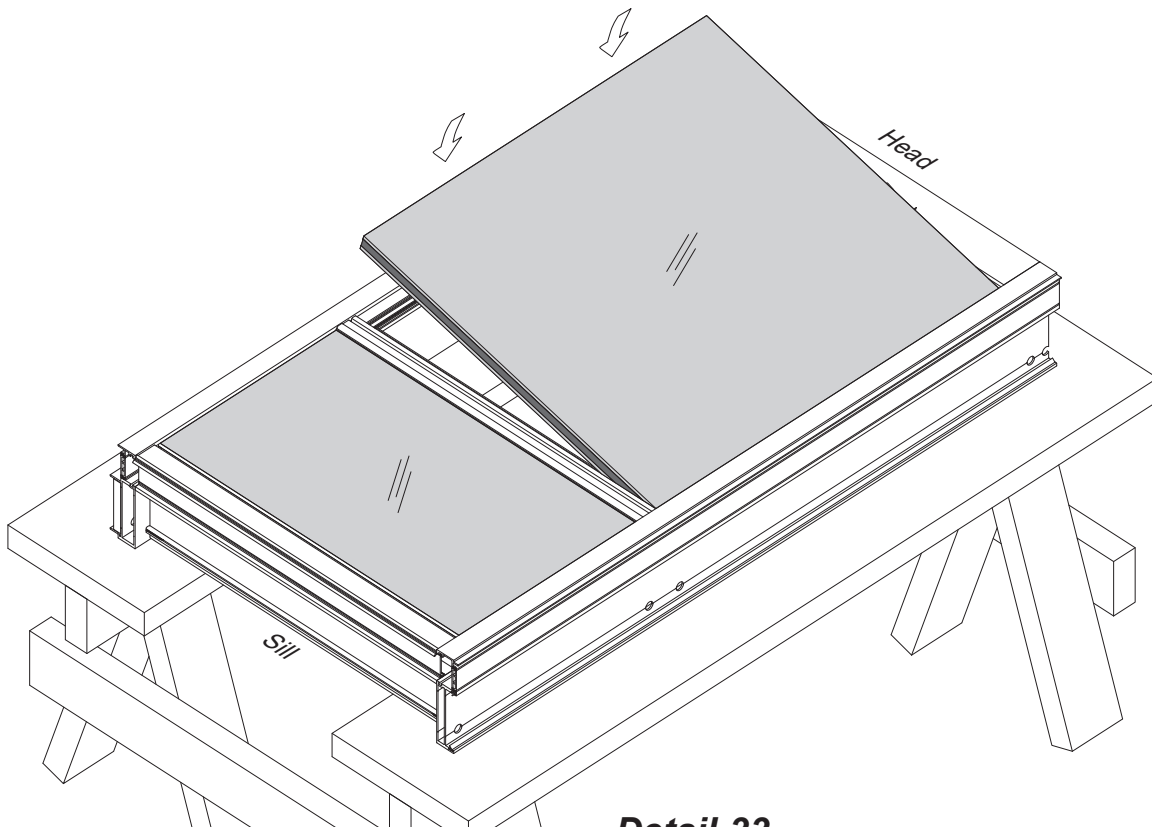

**Detail 33**  
 Outside Glazing  
 Shown, Inside  
 Glazing Similar

GLAZING

STEP 18 (Continued)  
INSTALL GLASS

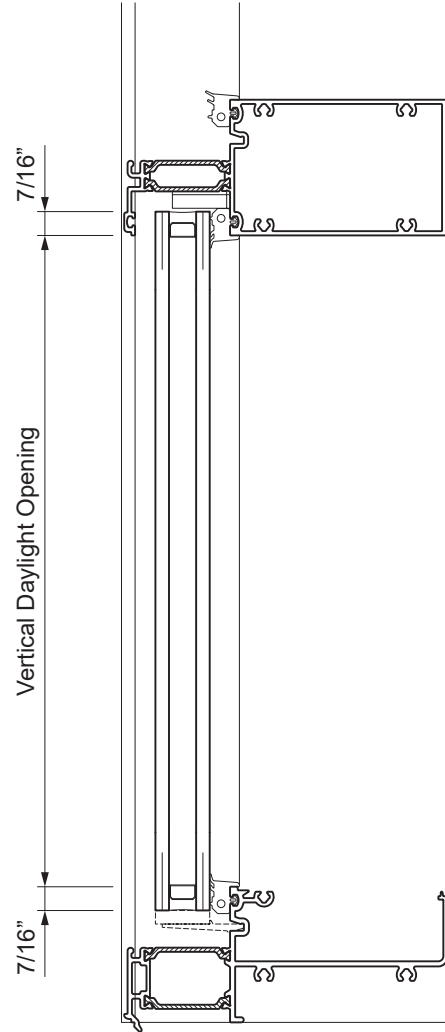

***Detail 34***  
Outside Glazing  
Shown, Inside  
Glazing Similar

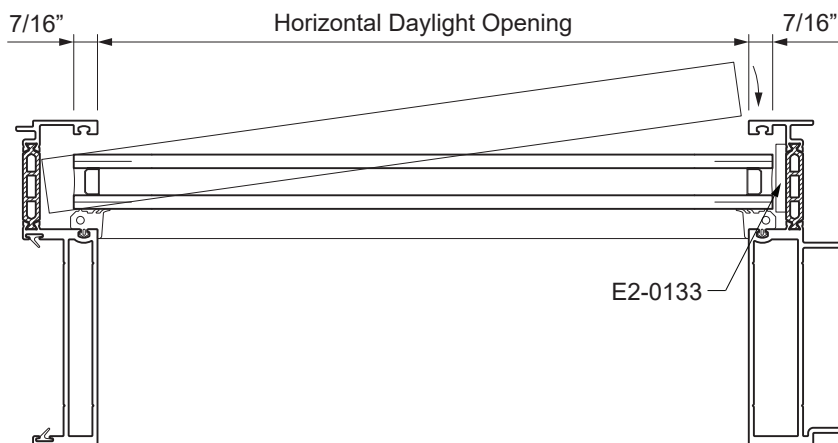

**GLAZING**

**STEP 19  
INSTALL SETTING BLOCKS (OUTSIDE GLAZING)**

- Setting blocks are installed at quarter points of the daylight opening, or according to the engineering calculations.
- Set the setting block chairs into the horizontals as shown in **Detail 35**.
- Apply sealant to the setting blocks and set them between the setting block chairs and the glass.
- Adhere the setting block chairs in place with sealant.

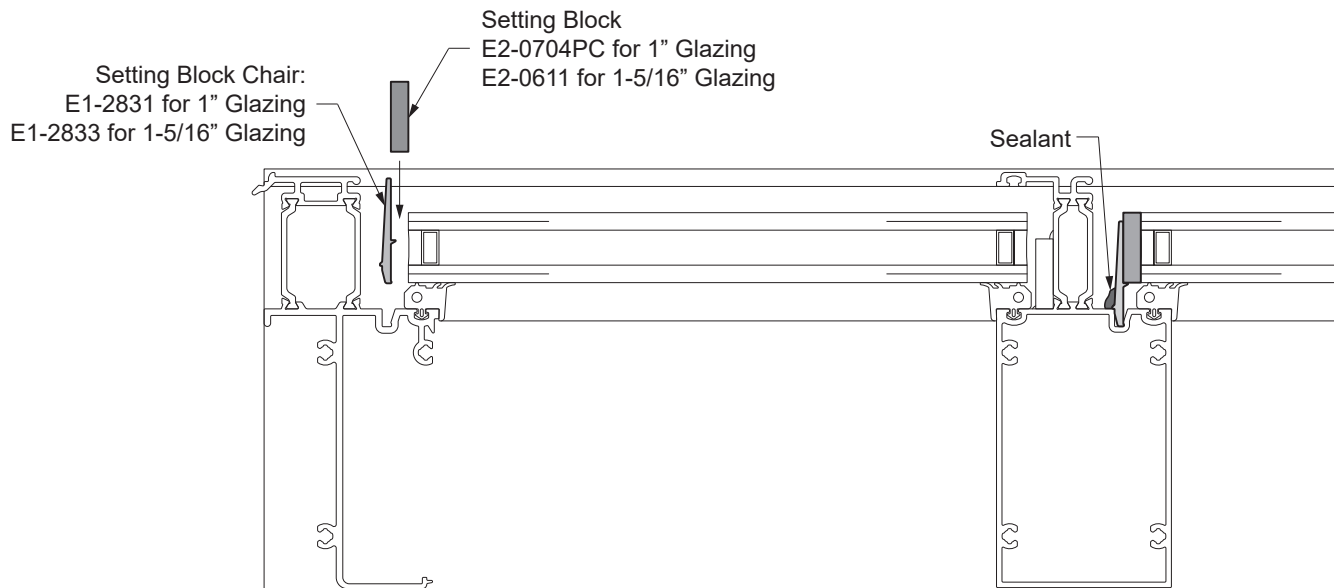

**Detail 35**  
Outside Glazing  
Shown, Inside  
Glazing Similar

GLAZING

**STEP 20A**  
**INSTALL ANTI-WALK BLOCKS (INSIDE GLAZING)**

Anti-walk blocks must be installed in the vertical deep glazing pocket of each lite centered along the daylight opening.

E2-0546 for all female mullions

-Flatten the anti-walk block against the surface of the glass and push it into the opening between the glass and the mullion until it is released into the glazing pocket.

-Adhere E2-0068 setting blocks with silicone to the frame at the topside of each lite at each end of the daylight opening. Be sure to set the setting block in the proper orientation as shown in **Detail 36A**. This will keep the glass from shifting as the unit is raised for installation. If the glass is oversized, trim the blocks to fit.

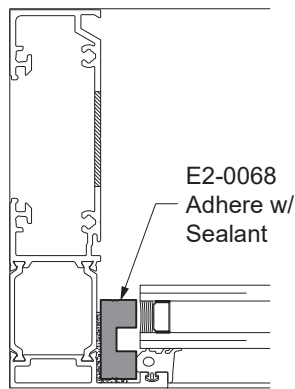

**Detail 36A**  
 Inside Glazing Shown

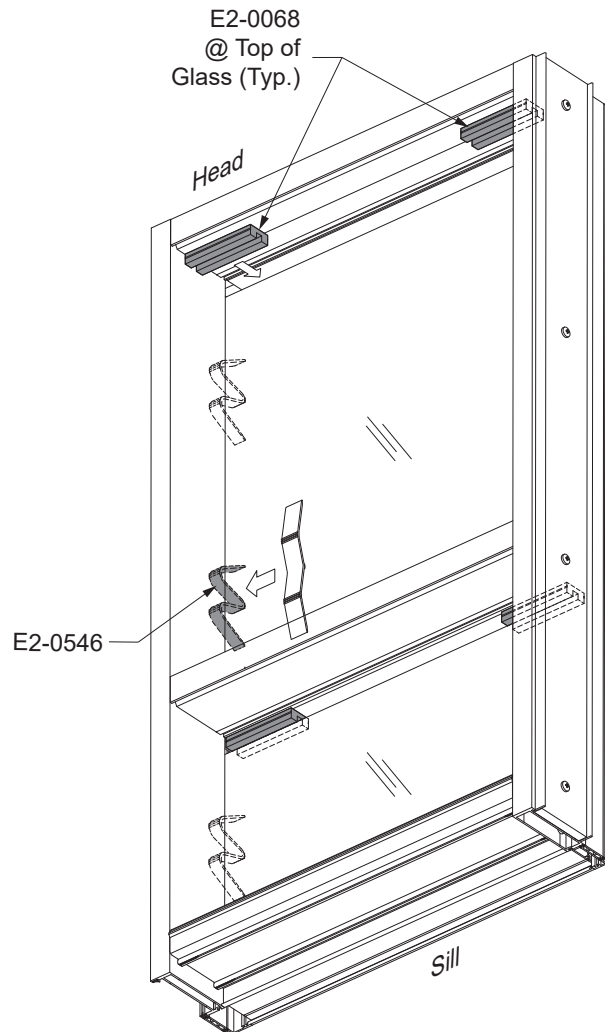

**Detail 36B**  
 Inside Glazing Shown

**GLAZING**

**STEP 20B  
INSTALL ANTI-WALK BLOCKS (OUTSIDE GLAZING)**

For all female mullions, anti-walk blocks (E2-0546) must be installed in the vertical deep glazing pocket of each lite centered along the daylight opening.

-Flatten the anti-walk block against the surface of the glass and push it into the opening between the glass and the mullion until it is released into the glazing pocket.

See **Detail 36C**.

**For Optional Head Members:**

-Adhere E2-0068 setting blocks with silicone to the frame at the topside of the uppermost glass lite at each end of the daylight opening as shown in **Detail 36D**. This will keep the glass from shifting as the unit is raised for installation. If the glass is oversized, trim the blocks to fit.

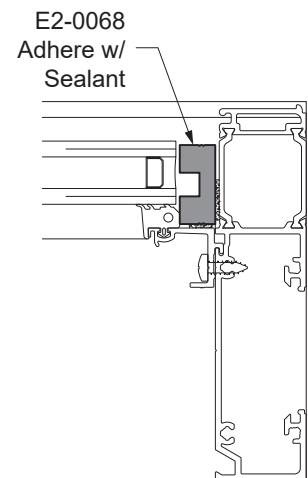

**Detail 36D**  
Outside Glazing Shown

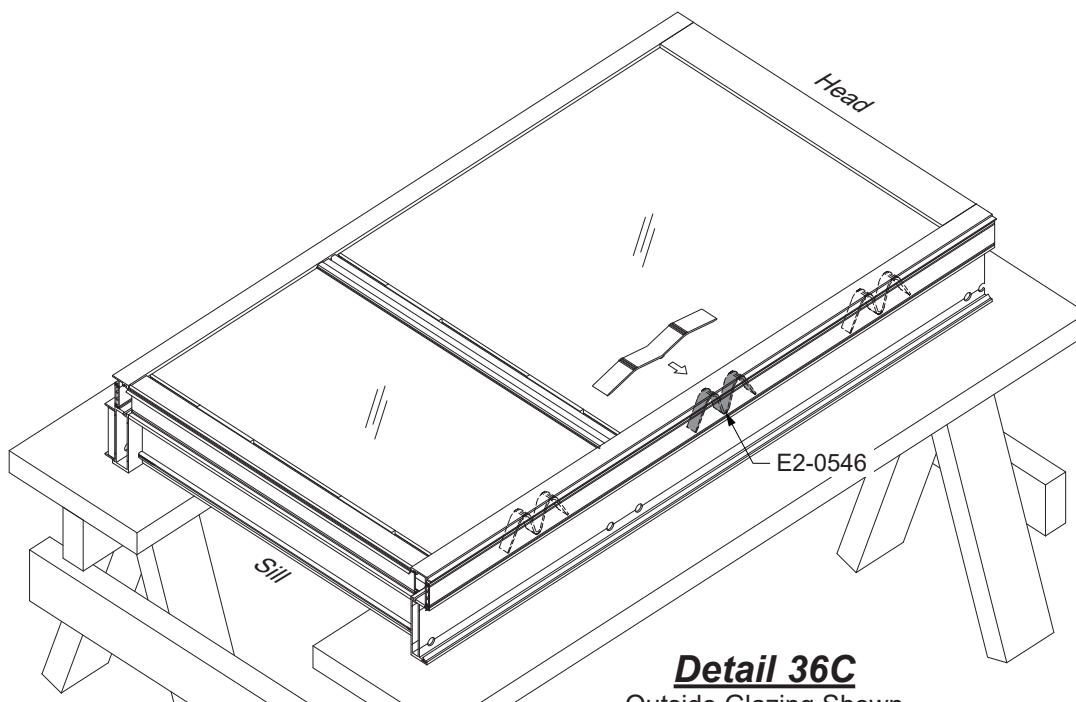

**Detail 36C**  
Outside Glazing Shown



**GLAZING**

**STEP 21A  
INSTALL GLASS STOPS (OUTSIDE GLAZING)**

- Seal the ends of the horizontal members against the exterior edge of the verticals.
- Set the glass stops in place.

See **Detail 37**.

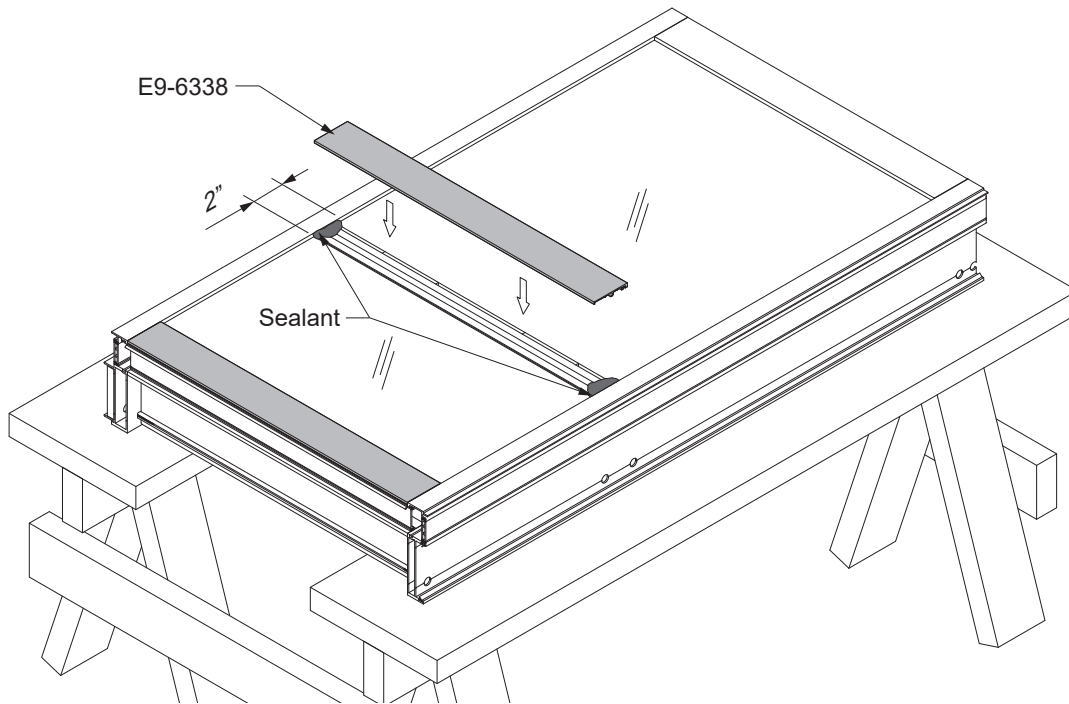

**Detail 37**

- To secure the intermediate glass stop to the unit, insert the wedge gasket (cut to D.L.O.) into the exterior of the glazing pocket, leaving the ends of the gasket out until the vertical gaskets are inserted.

See **Detail 38**.

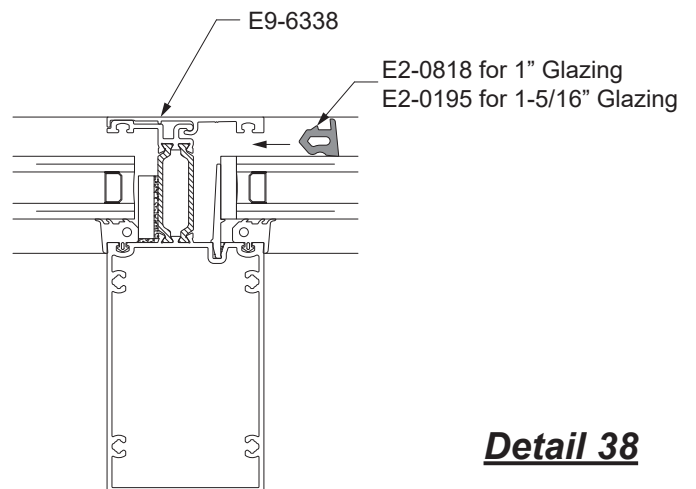

**Detail 38**

**GLAZING**

**STEP 21B  
INSTALL GLASS STOPS (INSIDE GLAZING)**

- Apply continuous sealant across the reglet where the E9-7852 glass stop will hook into.
- Also apply sealant to the top corners of the mullions where the glass stops will be joined against the mullion.
- Set the glass stops in place at the top of each daylight opening and secure the stop in place by drilling #12 tap holes (0.189" dia.) and using PC-1210 fasteners.
- Tool sealant at intersection of the glass stop to the vertical mullion.

See **Detail 39**.

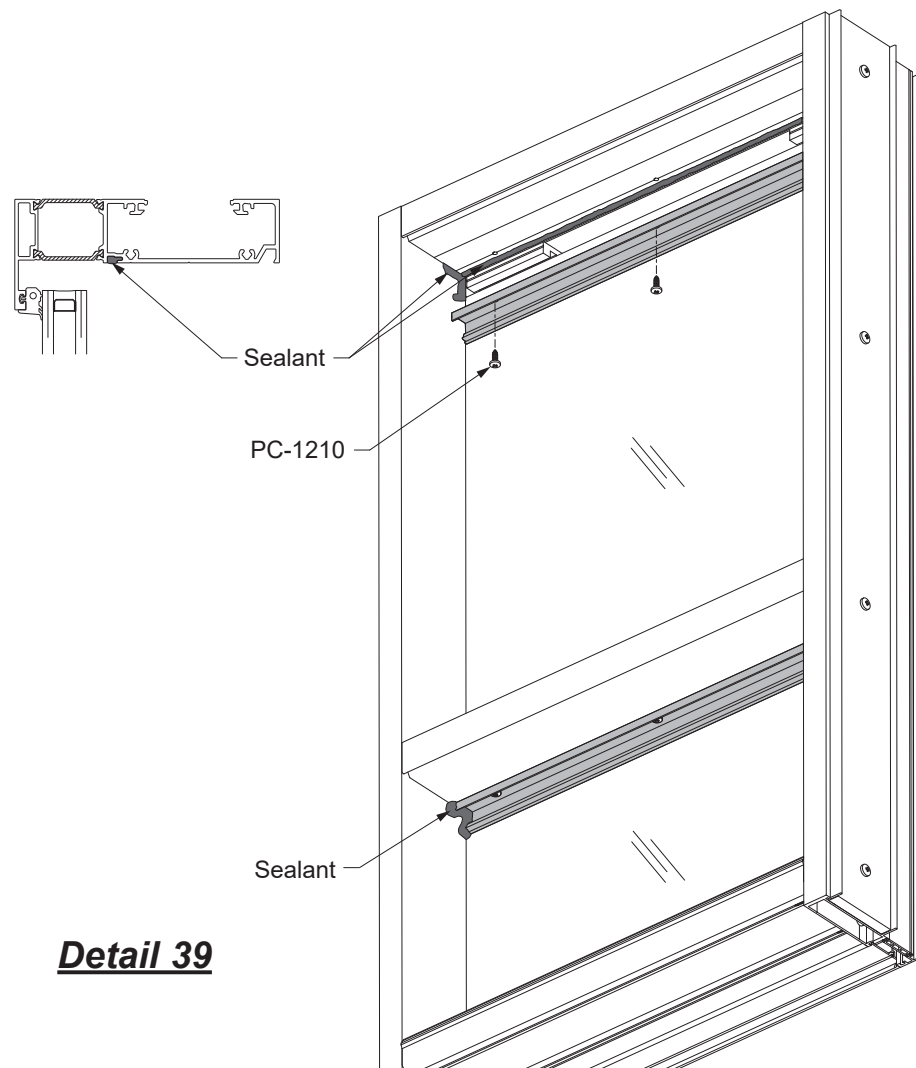

**Detail 39**

**Note:** Interior glass stops can be used on outside glazed units with inside reglazing option.

## GLAZING

### STEP 22

### SEAL GLASS TO SHALLOW POCKETS AT MALE MULLION

-In order to ensure the glass will not shift during transit, apply 6” of silicone sealant between the glass and the side blocks for the verticals of which side blocks are used. Avoid filling the entire pocket with sealant. Do not let the sealant cure before inserting the wedge gasket.

See **Detail 40**.

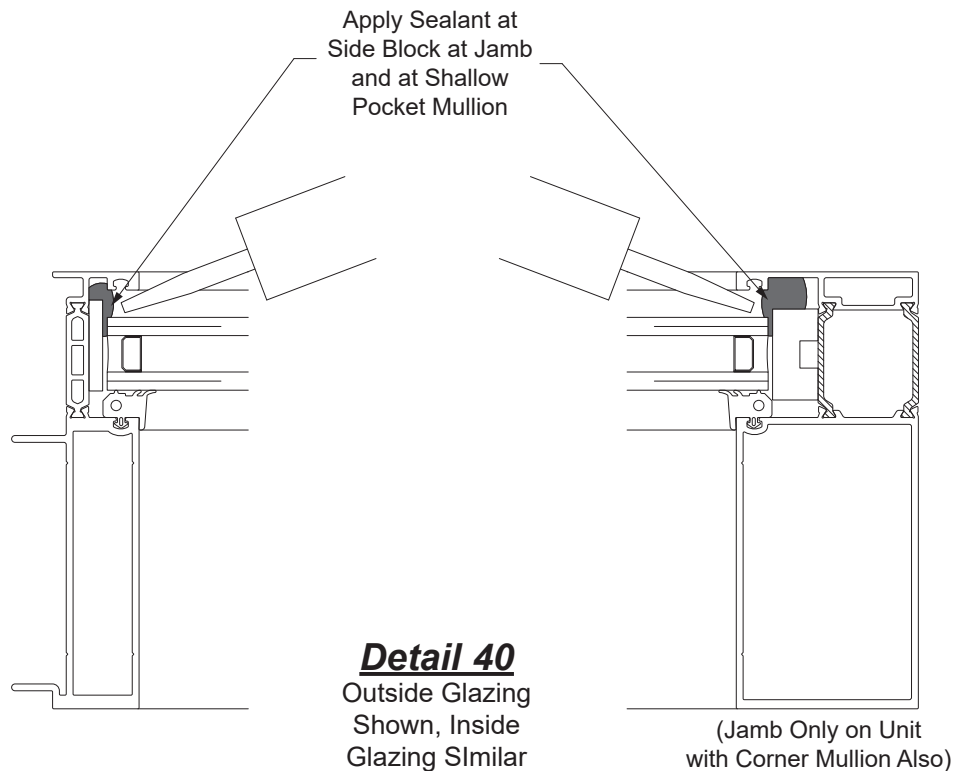

**GLAZING**

**STEP 23  
INSTALL WEDGE GASKETS**

-Cut vertical wedge gasket to Daylight Opening plus(+) 3/4", plus(+) an additional 1/4" every foot of length. Notch the ends of the gasket by 3/8" as shown in **Detail 41**.

-Insert the wedge gasket into the glazing pocket at end points first, then work towards the midpoint.

See **Detail 42**.

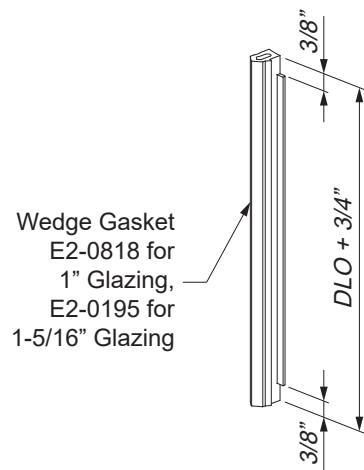

**Detail 41**

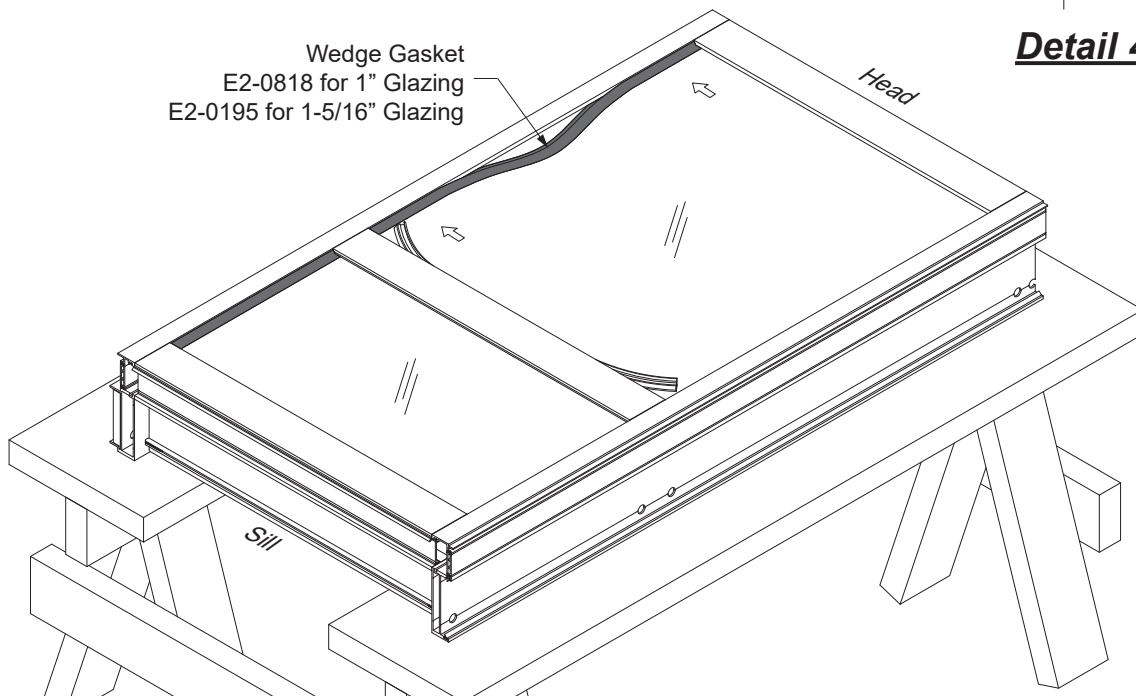

**Detail 42**  
Outside Glazing  
Shown, Inside  
Glazing Similar

## GLAZING

### STEP 23 (Continued) INSTALL WEDGE GASKETS

- Cut head and sill wedge gaskets to Daylight Opening plus(+) 1/4" for each foot of length.
- Apply silicone to each end of the gasket and also to the ends of the intermediate horizontal gaskets already inserted.
- Next, insert the horizontal gasket into the glazing pocket, centered on the Daylight Opening at each end first; then insert the gasket at the midpoint of the opening and work towards each end. Ensure the horizontal and vertical gaskets are sealed together. Tool excess silicone smooth.
- Affix E4-0008 (This Side Down) Static label to the glass, orienting the arrows to the sill and the mullion with the shallow pocket or the female with the setting blocks.

See **Detail 43**.

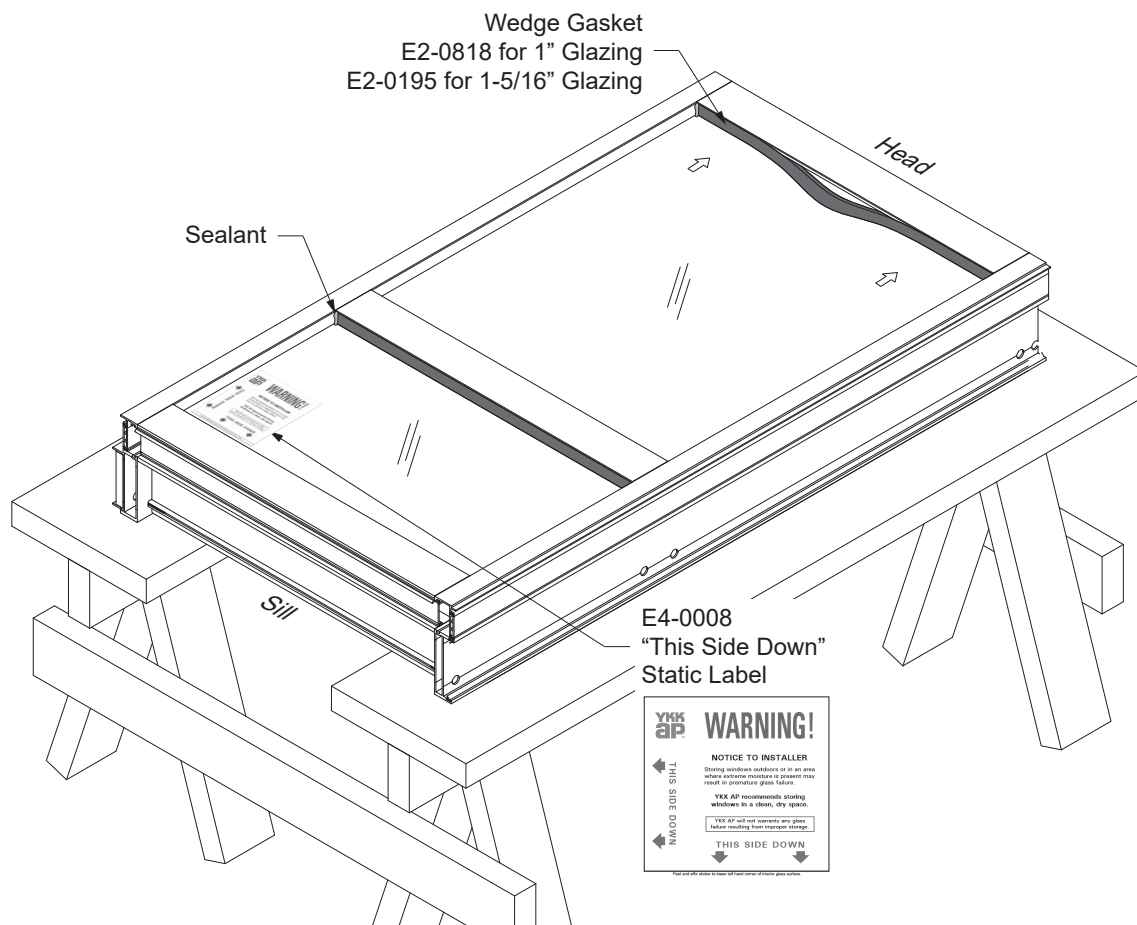

**Detail 43**  
Outside Glazing  
Shown, Inside  
Glazing Similar

**FRAME INSTALLATION**

**STEP 24  
INSTALL SILL FLASHING END DAMS**

-Bend the end dam tab left or right 90 degrees in order to “hand” the end dam for the left or right end of the flashing.

See **Detail 44**.

- Clean all joint surfaces using cleaner approved by sealant manufacturer.
- Apply sealant to the end of the sill flashing as shown in **Detail 45**.
- Slide the tab into the top portion of the sill flashing.
- Tap the tab into place with a small tool until the end dam is snug against the end of the flashing.
- Fasten the end dam to the sill flashing with two UA-1212 screws, starting at the back, followed by the front as shown in **Detail 45**.
- Tool sealant along the joint between the end dam and the sill flashing as shown in **Detail 46**.

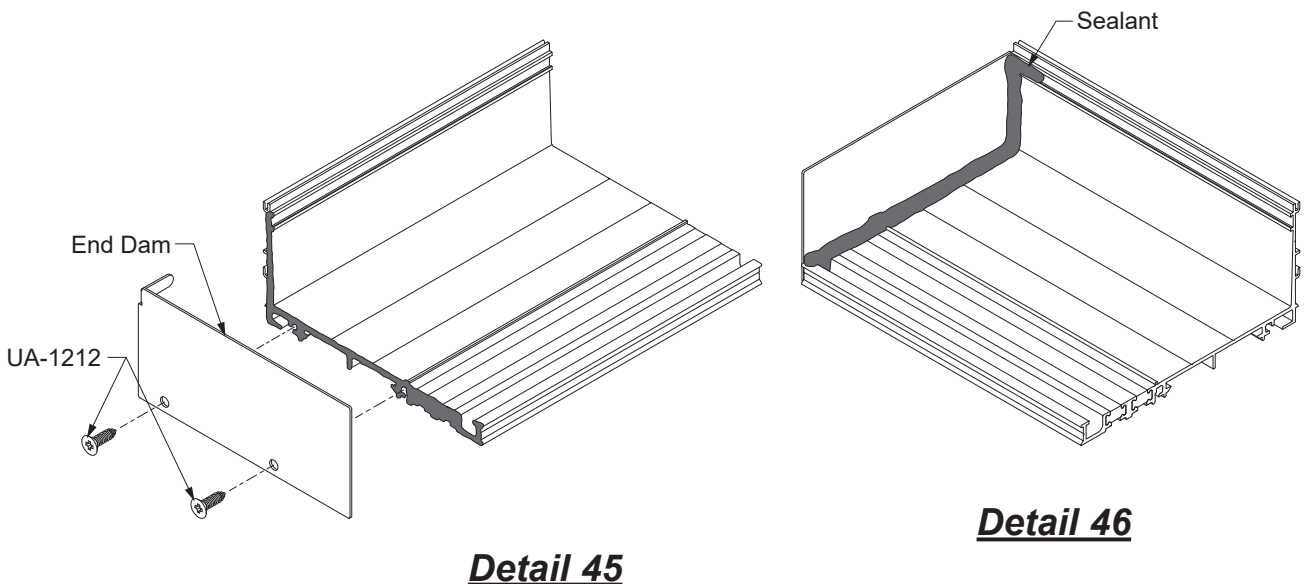
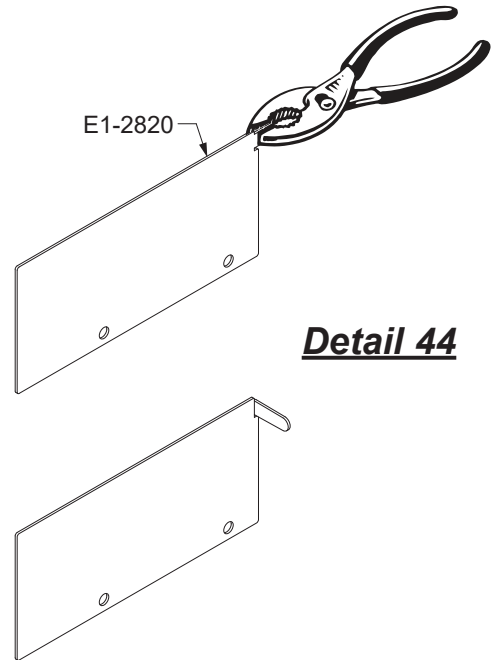

FRAME INSTALLATION

**STEP 24A**  
**INSTALL SILL FLASHING END DAMS FOR SLAB**  
**EDGE COVER**

- Sill flashings with slab edge covers will require an aluminum plate adaptor E9-8222 to be attached prior to field installation.
- Cut (2) E2-0065 weathering gaskets to length of the plate adaptor plus(+) 12". This will account for shrinkage.
- Insert the weathering gaskets into the reglets of the adaptor, leaving 6" on each side, and in the fin up orientation as shown in **Detail 47**.
- Slide the slab edge adaptor onto the sill flashing.
  
- Installation of the E1-1196 end dam is the same as illustrated in the previous page, except that the end of the installed slab edge adaptor will also require sealant.
- Fasten an E1-1196 end cap onto the slab edge assembly using an additional UA-1212 screw.

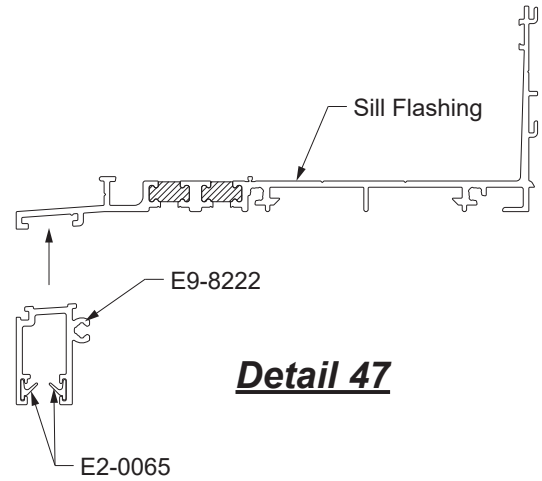

**Detail 47**

See **Detail 48**.

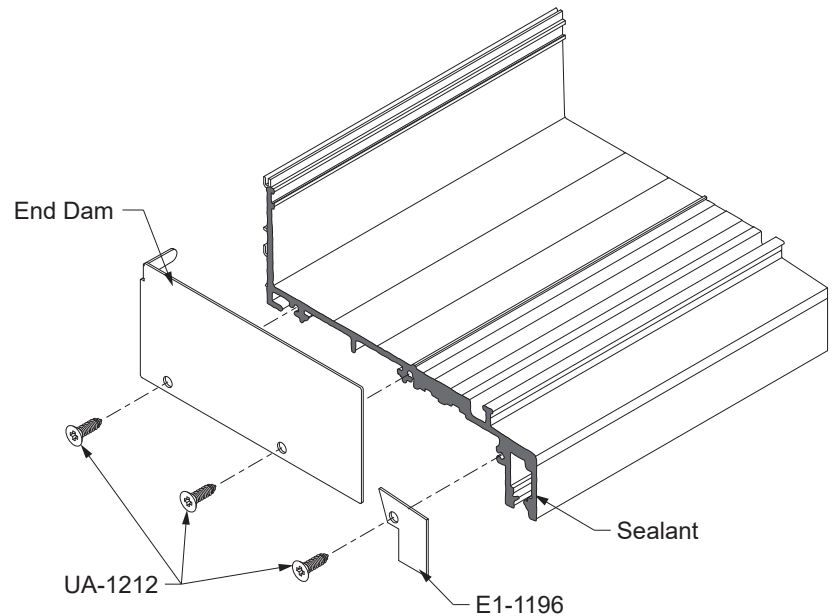

**Detail 48**

**FRAME INSTALLATION**

**STEP 25  
INSTALL BE9-6328 SILL FLASHING**

- Install the sill flashing with a minimum of 3/8" shim space underneath. Sill flashing must be installed level.
- Anchor the sill flashing to the structure a maximum of 4" from each end and then 18" to 24" on center or per P.E. calculations.
- Apply and tool sealant to cover the heads of all anchors and screws.

**STEP 26  
INSTALL SILL FLASHING SPLICE SLEEVE**

- Remove the nub with a chisel or pliers on both sides of the splice joint 1-1/2" as shown in **Detail 49**.
- After the sill flashing has been shimmed and anchored to the building structure, insert a small backer rod under the sill flashing as shown in **Detail 50**.
- Position the Silicone Splice Sleeve against the back wall below the groove.
- Bend the Silicone Splice Sleeve into the front on the channel as shown. Mark and cut the sleeve at this position.
- Clean Sill Flashing and Silicone Splice Sleeve with isopropyl alcohol at the splice location.
- Seal the flashing at the splice location as shown in **Detail 50**, before positioning the flashing. Set the Silicone Splice Sleeve into the sealant.
- Tool sealant tight as shown in **Detail 50**, squeezing the sheet flat with a seam roller.

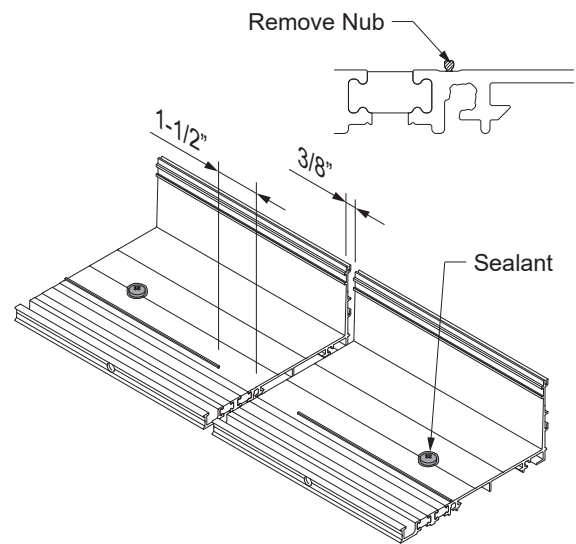

**Detail 49**

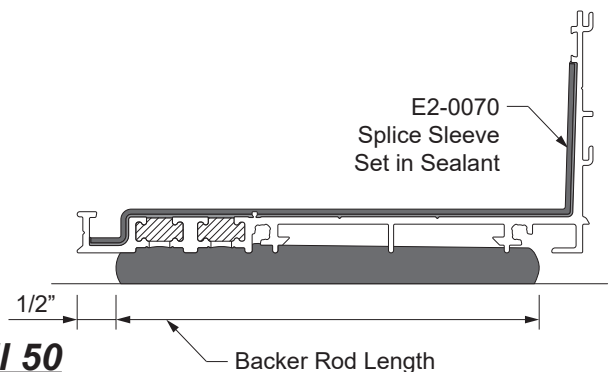
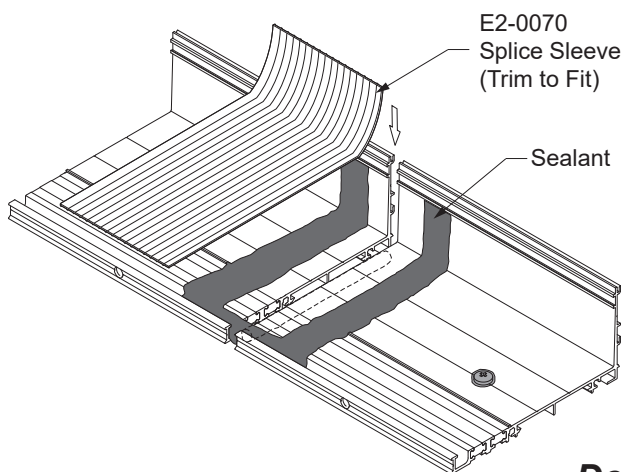

**Detail 50**



## FRAME INSTALLATION

### STEP 26 (Continued) INSTALL SILL FLASHING SPLICE SLEEVE

-Thoroughly seal the small joint directly in front of the Silicone Splice Sleeve as shown in **Detail 51**.

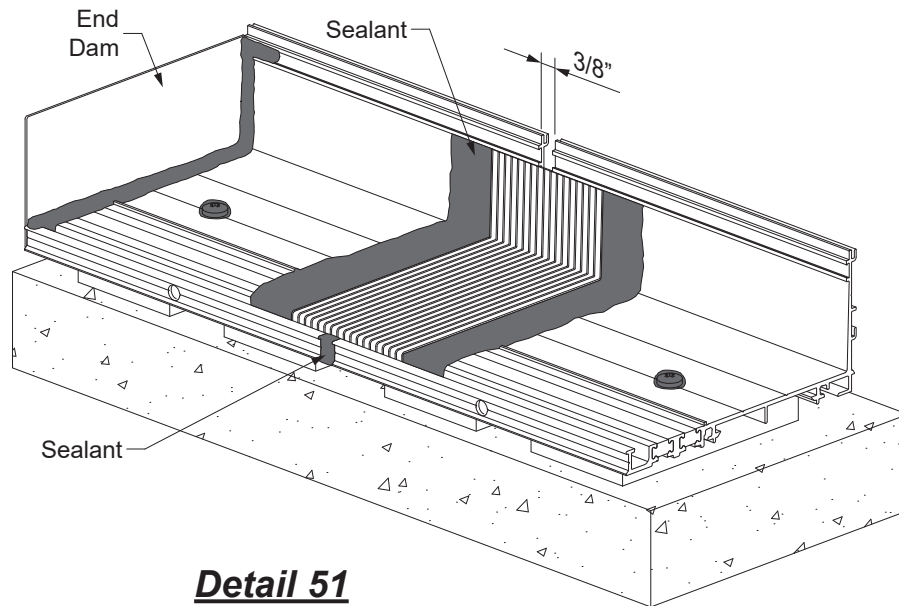

**Detail 51**

**FRAME INSTALLATION**

**STEP 27  
SLAB EDGE COVER INSTALLATION**

Slab edge covers are installed from the head of the lowest elevation on upward. The BE9-6331 head receptors are installed first, then slab edge plates, then the BE9-6330 sill flashings with the E9-8222 slab edge adaptors.

**STEP 27A  
INSTALL HEAD RECEPTOR END DAMS & WEATHERING GASKETS**

- Cut the E2-0051 airtight gasket to head receptor length plus 3/16" at each end for the splice joint, and insert it into its reglet for both the receptor and snap cover as shown in **Details 52 & 52A**.
- Cut the E2-0065 slab edge weathering gaskets to head receptor length plus 12". Insert the gaskets into the slab edge reglets in the fin down orientation as shown in **Detail 52A**, leaving 6" on each side.

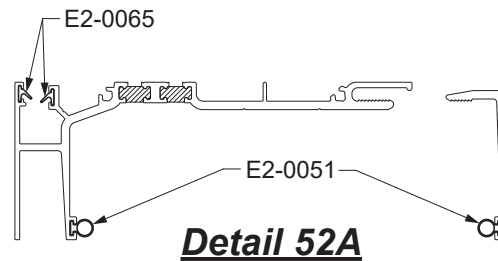
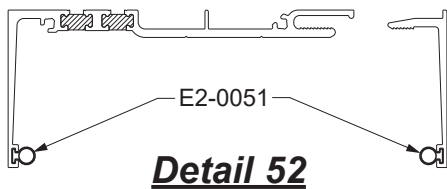

- Clean all joint surfaces using cleaner approved by sealant manufacturer.
- Apply sealant to the end of the head receptor as shown in **Detail 50**.
- Fasten the end dam to the head receptor with two UA-1212 screws, starting at the back, followed by the front.
- Tool sealant along the joint between the end dam and the head receptor as shown in **Detail 53**.
- Tape down the top corners to hold the end cap in place until the sealant cures.

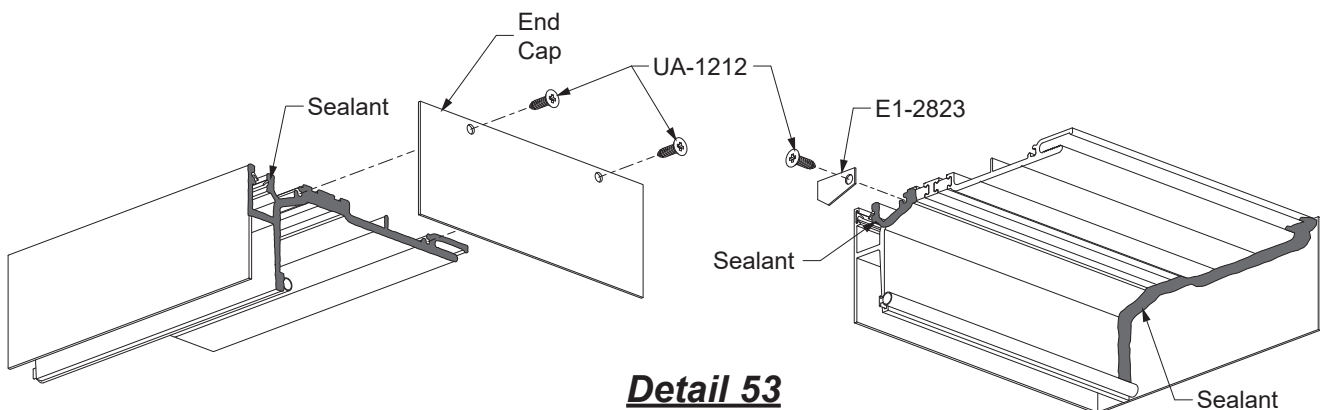

## FRAME INSTALLATION

### STEP 27B INSTALL HEAD RECEPTOR

- Prior to installing the head receptor, trim the E2-0065 to length of the receptor.
- Starting at the smallest opening height, install the head receptor with the appropriate shim space (1/2" minimum) to ensure the dimensions from the approved shop drawings. Head receptor must be installed level.
- Anchor the head receptor to the structure according to approved shop drawings and or P.E. calculations.
- Apply and tool sealant to the heads of all fasteners as shown in **Detail 54**.

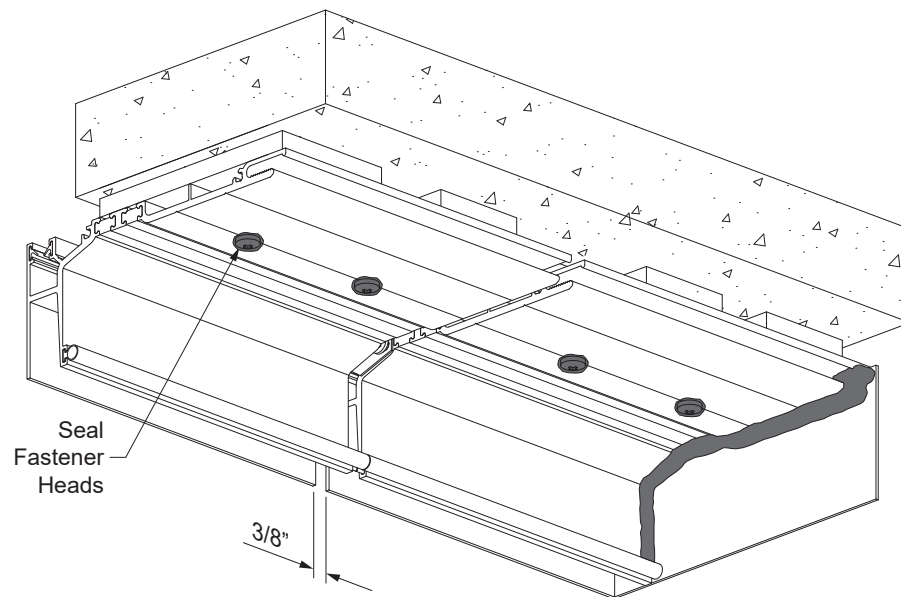

**Detail 54**

**FRAME INSTALLATION**

**STEP 27B (Continued)  
INSTALL HEAD RECEPTOR**

- Prior to installing the Silicone Splice Sleeve, clean head receptor and Splice Sleeve with isopropyl alcohol at the splice location.
- Position the Splice Sleeve, E2-0070, against the front wall inside the head receptor, set in sealant centered on the splice joint as shown in **Detail 55**. Trim as necessary to fit.
- Tool the sealant. Use a seam roller to press the sheet tight against the receptor.
- Seal the ends of the E2-0051 gasket together at the splice.

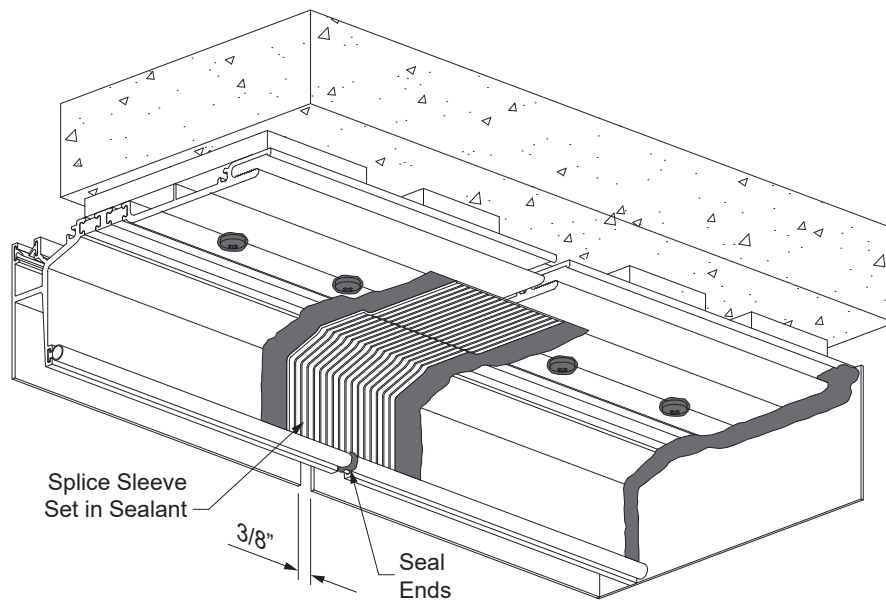

**Detail 55**

FRAME INSTALLATION

**STEP 27B (Continued)**  
**INSTALL HEAD RECEPTOR SPLICE SLEEVE**

-At the exterior joint of the head receptor, position an E1-9961 splice sleeve centered on the splice joint. Set the splice sleeve in sealant, similar to the procedure previously outlined for the underside of the head receptor.

See **Detail 56**.

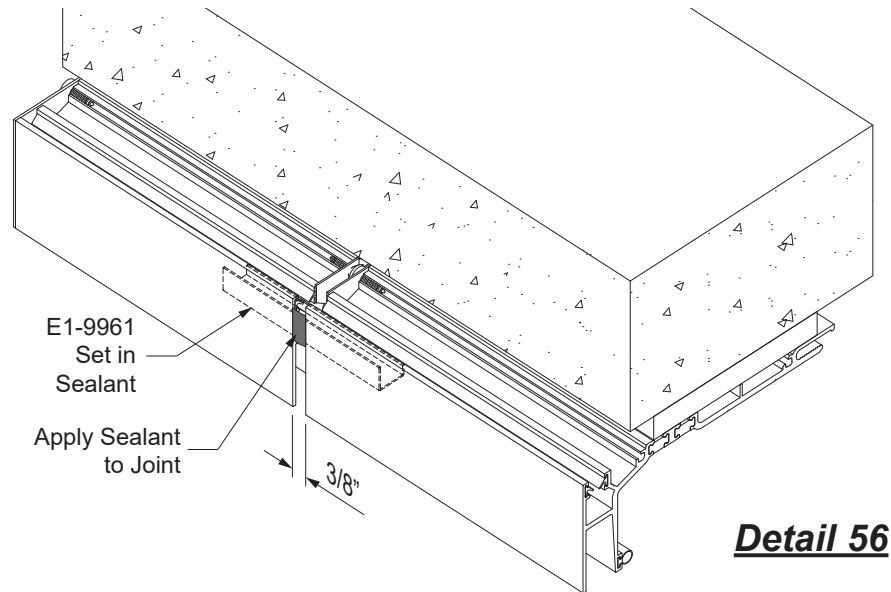

- Install E2-0054 setting blocks at 1/4 points of the aluminum plate.
- Install a weep baffle, E2-0099, over every weep hole location.
- Do not install the snap cover yet.

See **Detail 57**.

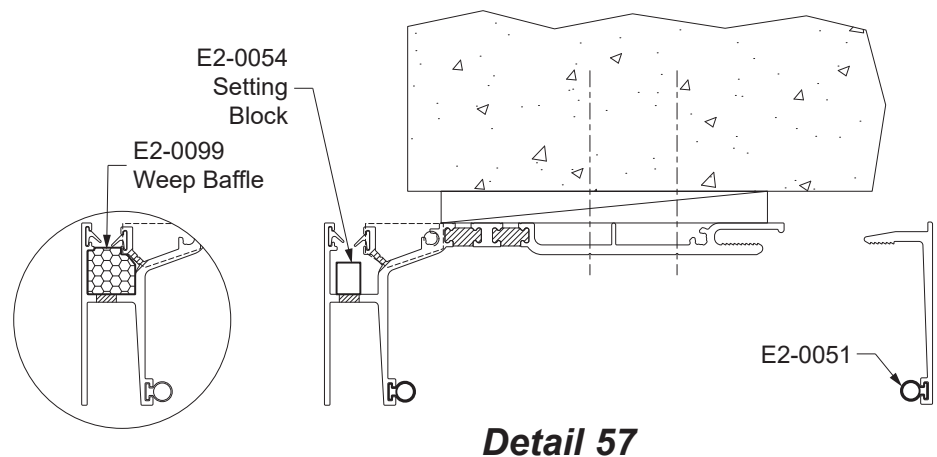

**FRAME INSTALLATION**

**STEP 27C  
ASSEMBLE SLAB EDGE COVER PLATES**

- Clean the ends of the slab edge cover and attachment areas of end caps using a cleaner approved by sealant manufacturer.
- Apply and tool sealant to each end of the slab edge cover prior to attaching the end caps.
- Attach end caps to each end of the slab edge cover using (2) UA-1212 fasteners.
- Tool and wipe away any excess sealant at the joints.

See **Detail 58**.

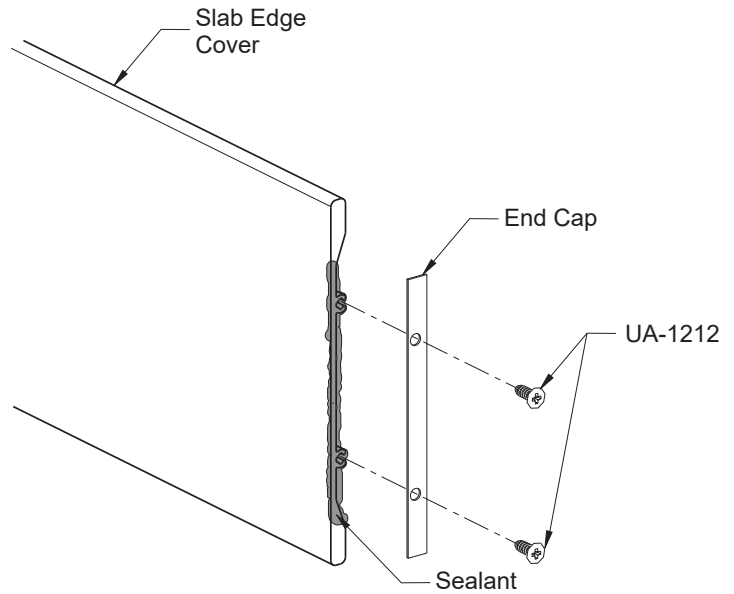

**Detail 58**

**STEP 27D  
INSTALL SLAB EDGE COVER FASCIA**

- Slide the slab edge cover plate into the head receptor receptacle, seating it on top of the setting blocks.
- Be sure to leave a 3/8" joint between the plates for runs longer than 24'-0".

See **Detail 59**.

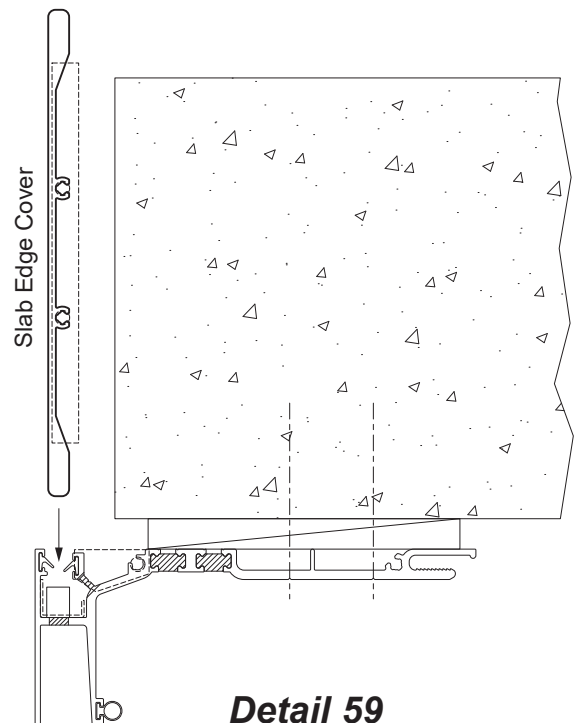

**Detail 59**

**FRAME INSTALLATION**

**STEP 27E (Continued)**

**INSTALL SILL FLASHING SPLICE SLEEVE AT SLAB EDGE**

- Prior to installing the sill flashing, trim the E2-0065 weathering gaskets to length of the slab edge adaptor.
- Install the sill flashing assembly onto the substrate, with a 1/2" minimum shim space, engaging the slab edge cover plates below and sealing all anchor fastener heads.
- Install the next slab edge sill flashing assembly onto the splice sleeve as shown in **Detail 60**. Be sure to leave a 3/8" splice joint between the sill flashing assemblies.

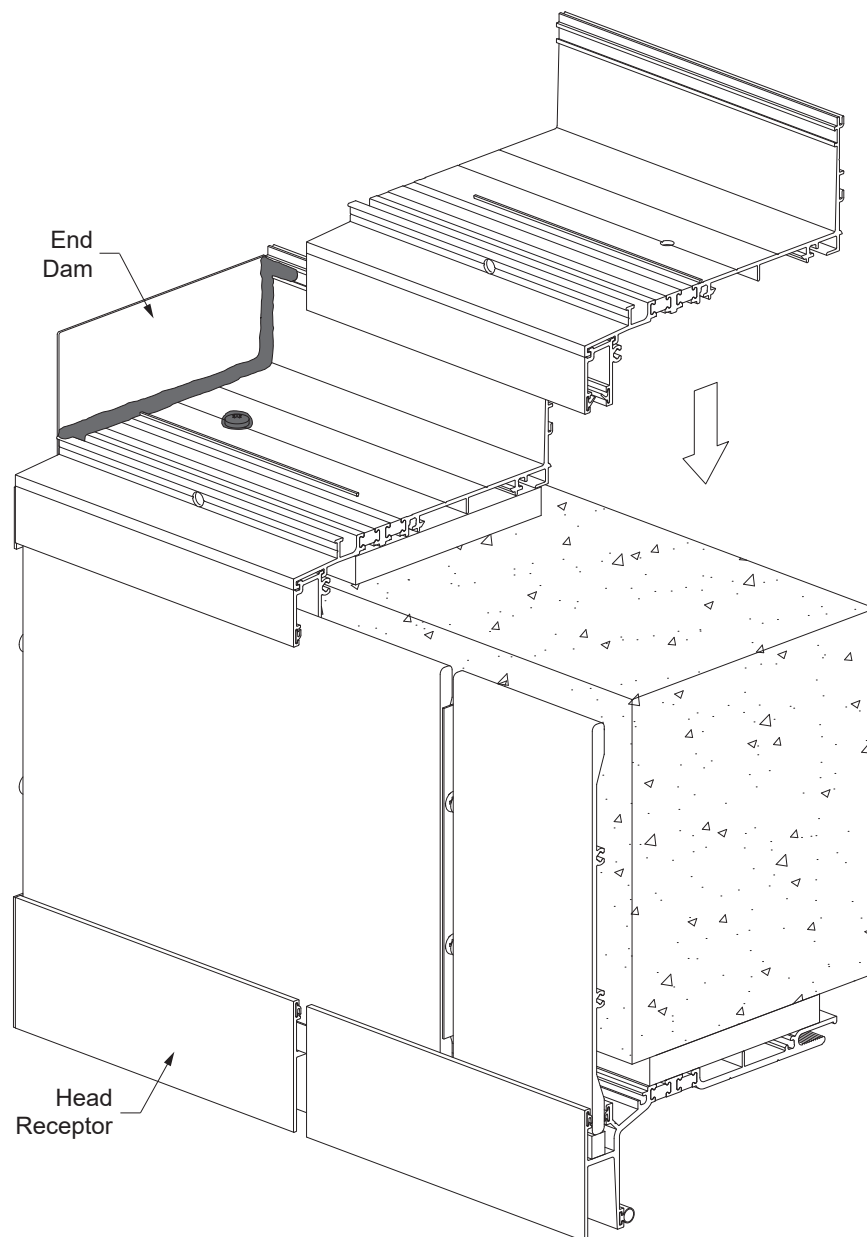

**Detail 60**

**FRAME INSTALLATION**

**STEP 27E (Continued)**

**INSTALL SILL FLASHING SPLICE SLEEVE AT SLAB EDGE**

-Installation of the E2-0070 splice sleeve is the same as previously outlined in **Step 26**, except to apply sealant to the joint at the slab edge cover plate, adaptor, and head receptor as shown in **Detail 61**.

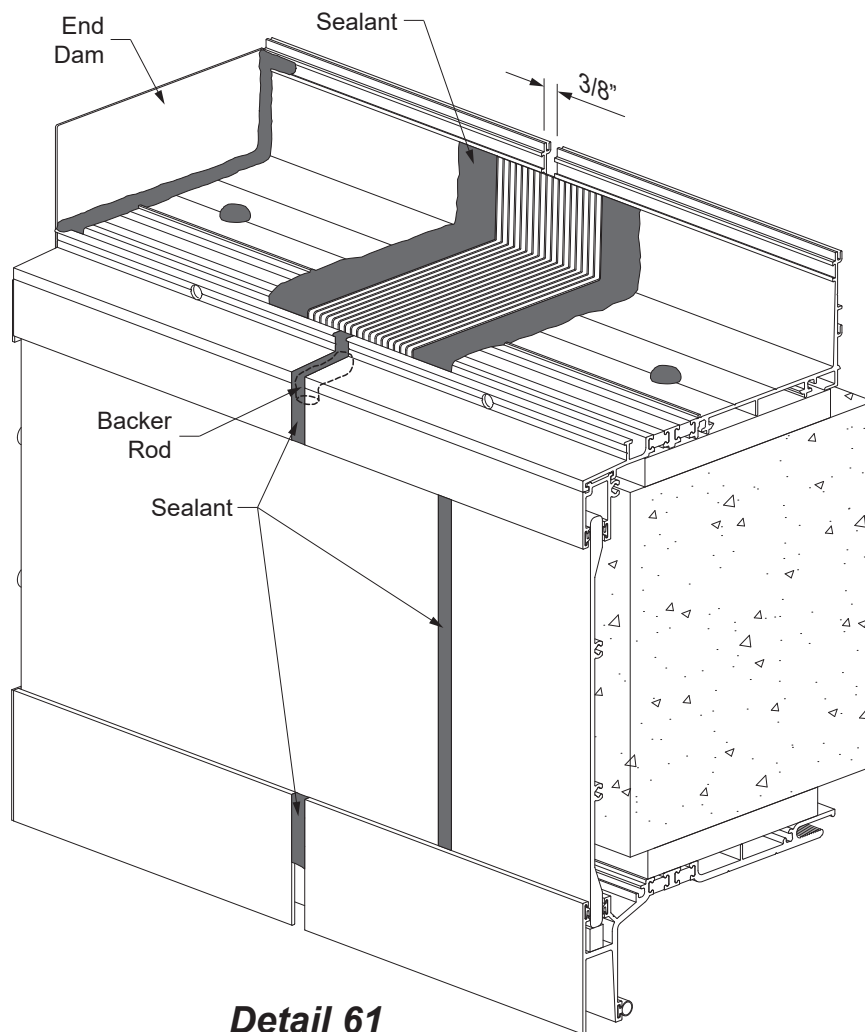

***Detail 61***



FRAME INSTALLATION

**STEP 28**  
**INSTALL SILL FLASHING AT CORNERS**

- Cut two 18" minimum long pieces of BE9-6328 sill flashing and miter (45° for 90° corners) as shown in **Detail 62**.
- Align the two pieces at the corner condition with the mitered ends pushed together tight and anchor the sill flashing as indicated on the approved shop drawings and or P.E. calculations.
- Apply and tool sealant to the mitered joint and anchor heads.

See **Detail 62**.

- Continue installing the rest of the sill flashing providing a 3/8" joint at splices as shown on **Pages 44 & 45**.

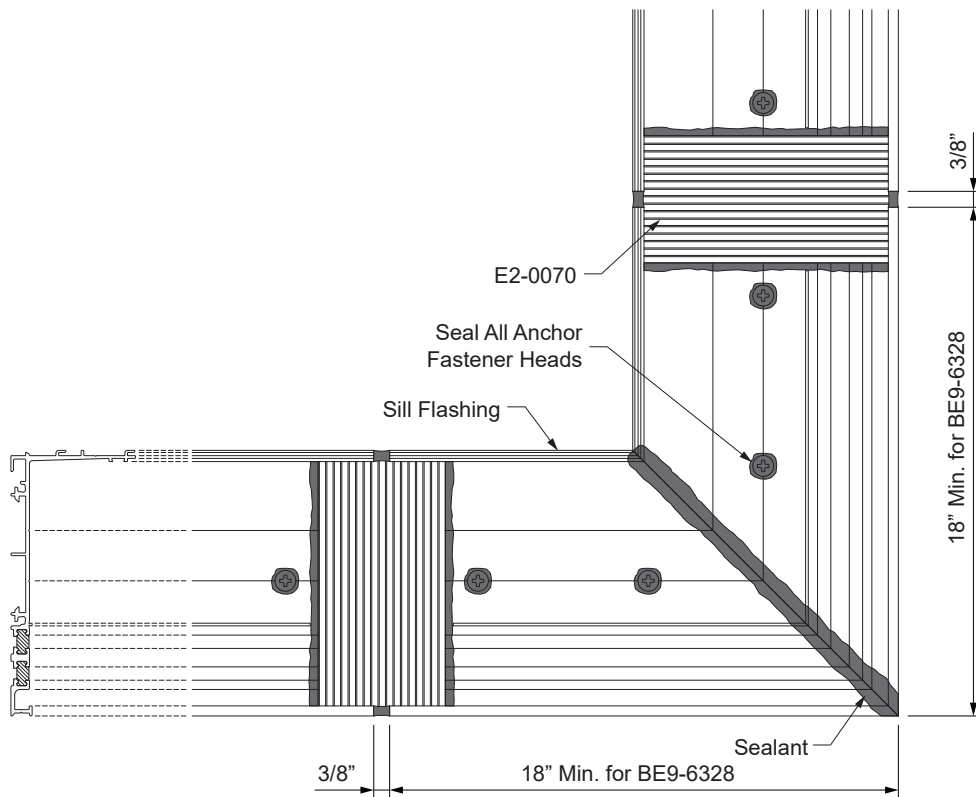

**Detail 62**

**FRAME INSTALLATION**

**STEP 28A**

**INSTALL SILL FLASHING AT CORNERS FOR SLAB EDGE COVER\***

- Cut two 19-3/16” minimum long pieces of sill flashing and E9-8222 slab edge cover adaptor, and miter (45° for 90° corners). The head receptor that is to be installed below will also receive the same miter cut fabrication.
- Install the head receptor using similar procedure as previously described for the sill flashing.
- Miter cut the slab edge cover plates 45° for 90° corners, such that upon installation, they leave a 1/2” gap at the corner.
- Fasten end caps onto the edge of the slab edge cover plates.
- Install the slab edge plates onto the setting blocks of the head receptor below.
- Align the two pieces of the sill flashing at the corner condition with the mitered ends pushed together tight and anchor the sill flashing as indicated on the approved shop drawings and or P.E. calculations.
- Apply and tool sealant to the mitered joint and anchor heads.

See **Detail 63**.

- Continue installing the rest of the sill flashing providing a 3/8” expansion joint at splices as shown in **Pages 44 to 52**.

\* **Note:** Similar technique required for head receptor.

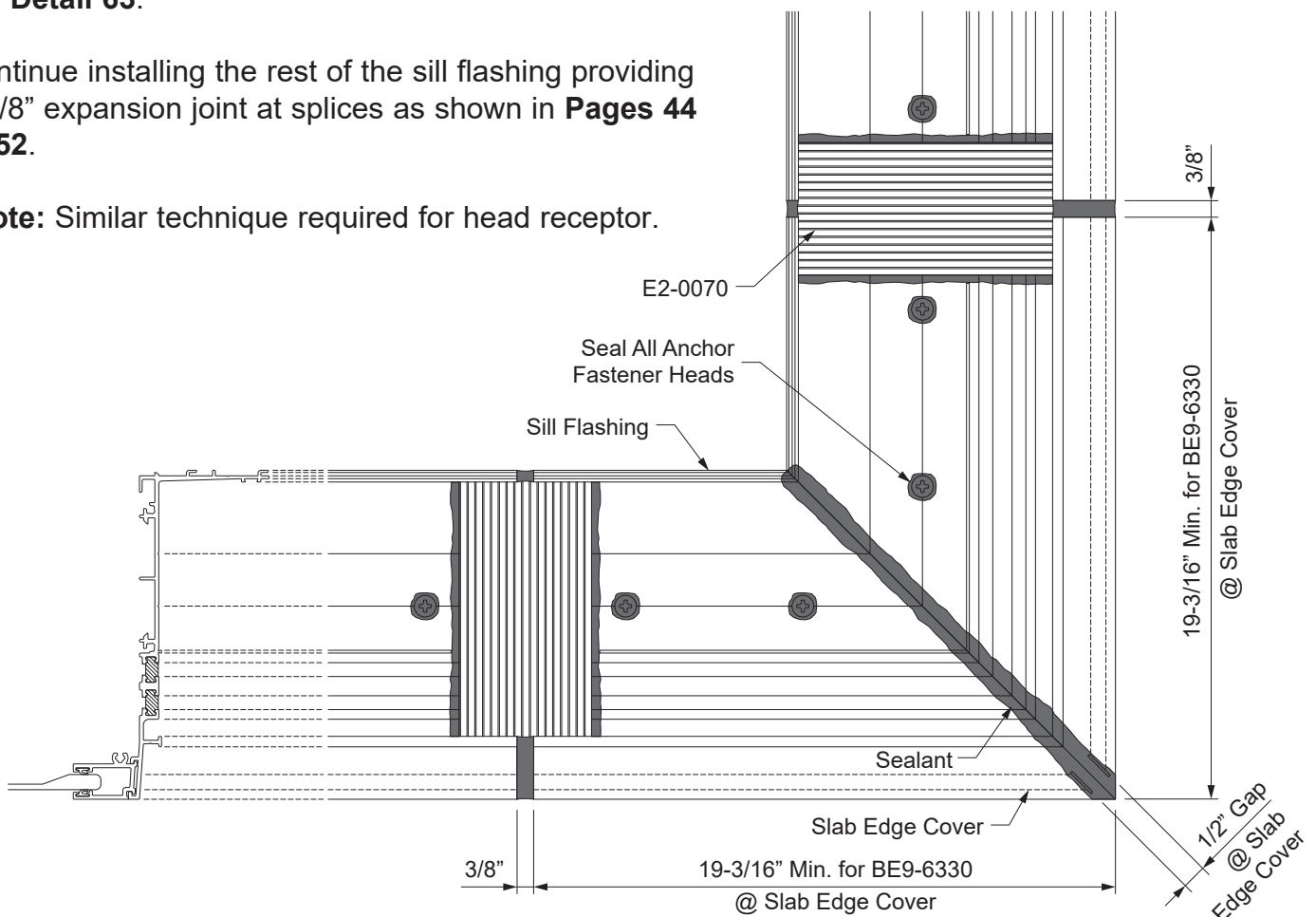

**Detail 63**

## FRAME INSTALLATION

### STEP 29 SILL PREPARATION

At every splice condition, apply bond breaker tape to the back of the sill member before the joint is sealed between the sill and sill flashing.

See **Detail 64**.

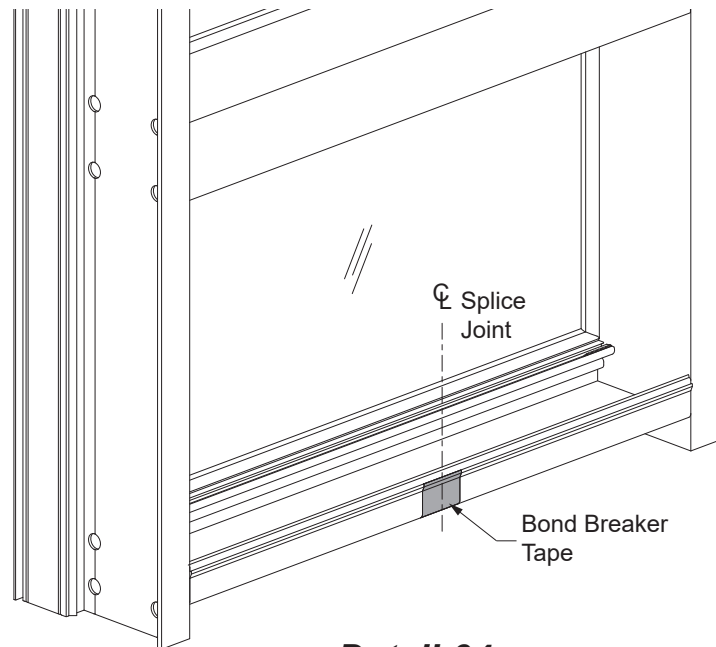

***Detail 64***

**FRAME INSTALLATION**

**STEP 30  
INSTALL FRAMES**

- The male mullion half of the second unit engages into the female mullion half of the previously installed unit, from the side, as shown in **Detail 65**.
- For frames that utilize the E1-2830 channel shaped head anchor, secure the anchor to the head using masking tape as shown in **Detail 66** prior to installation into the frame opening.
- Set the frame into place. See **Detail 67** for shim space at head.
- Taking care to ensure the framing unit is plumb, level, square, and true, anchor the framing unit to the substrate, first at the head using fasteners as specified by engineering calculations.

See **Detail 67**.

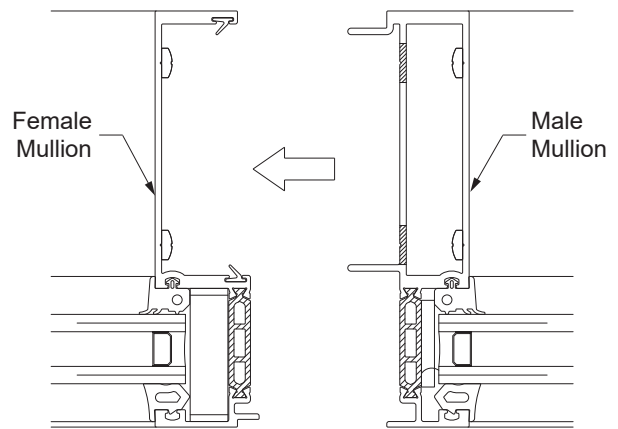

**Detail 65**

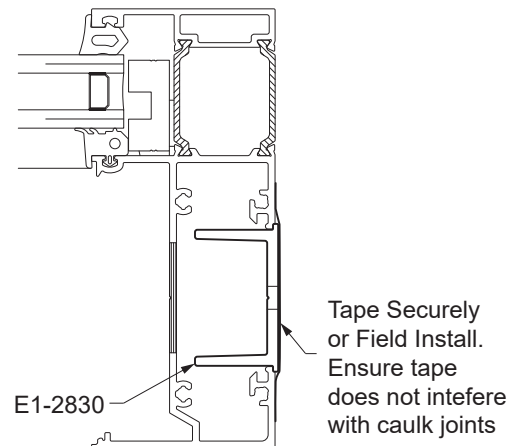

**Detail 66**

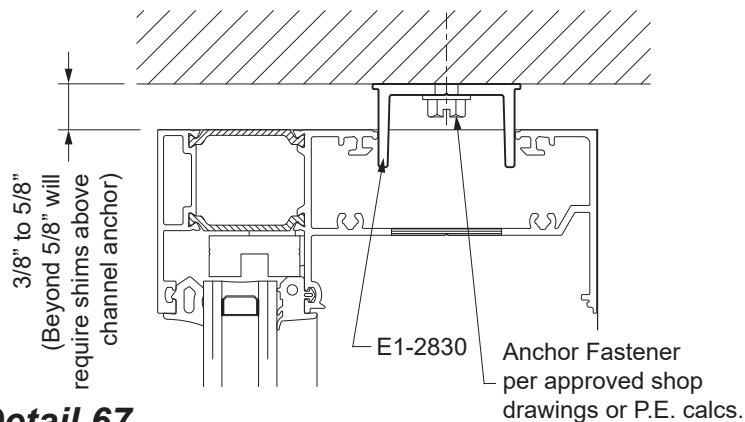

**Detail 67**

## FRAME INSTALLATION

### STEP 30 (Continued) INSTALL FRAMES WITH HEAD RECEPTOR

- Set the frame into place, taking care to ensure the unit is plumb, level, square, and true.
- Snap on the E9-6343 receptor snap cover with the E2-0051 airtight gasket onto the head receptor.

See **Detail 68**.

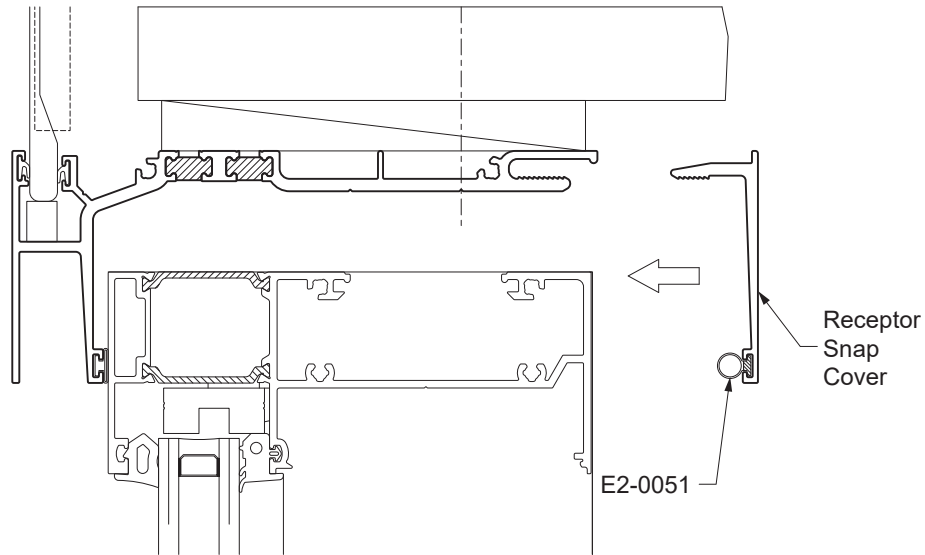

**Detail 68**

**FRAME INSTALLATION**

**STEP 30 (Continued)**

**APPLY CORNER MULLION SPACER TAPE**

-For the first unit at the corner, apply E2-0110 spacer tape to the corner mullion, the full height of the mullion as shown in **Detail 69**. Do not apply the spacer tape to the corner mullion of the adjoining unit.

**Note:** Contact surface must be clean and dry prior to application of spacer tape.

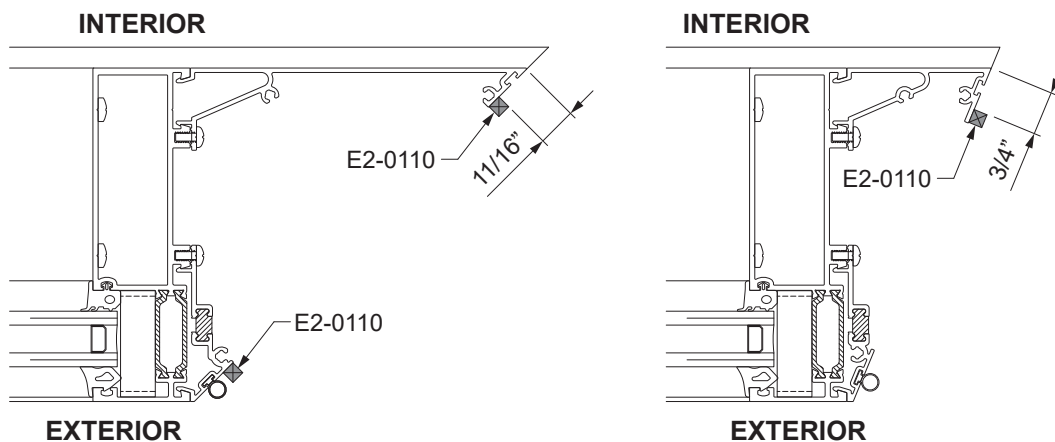
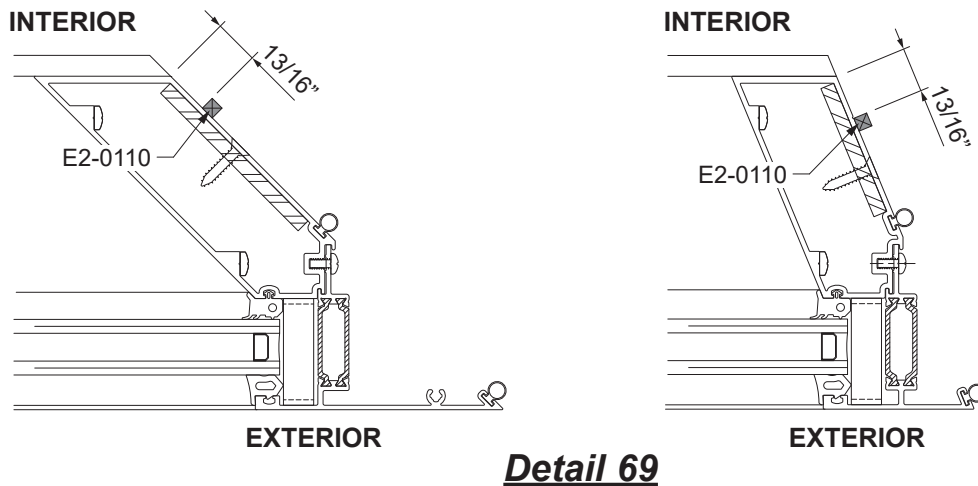

**FRAME INSTALLATION**

**STEP 30 (Continued)**  
**INSTALL FRAMES**

**Note:** If sill has not fully engaged into the sill flashing, first ensure the front of the sill is fully engaged with front of the flashing. Then, tap down with a block of wood to ensure proper engagement prior to sealing (after mullion has been properly placed.)

See **Detail 70**.

-Just prior to installing the next unit, apply sealant to the interior reglet of the female mullion where it will interface with the male mullion of the installed unit (from bottom of mullion and 6" up.) Also, apply 6" of sealant to the sill flashing centered on the mullion centerline (3" at the jamb) as shown in **Detail 71**.

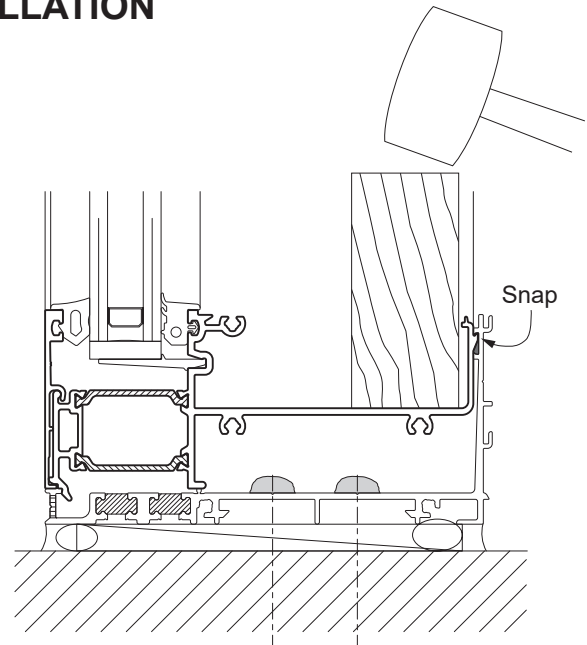

**Detail 70**

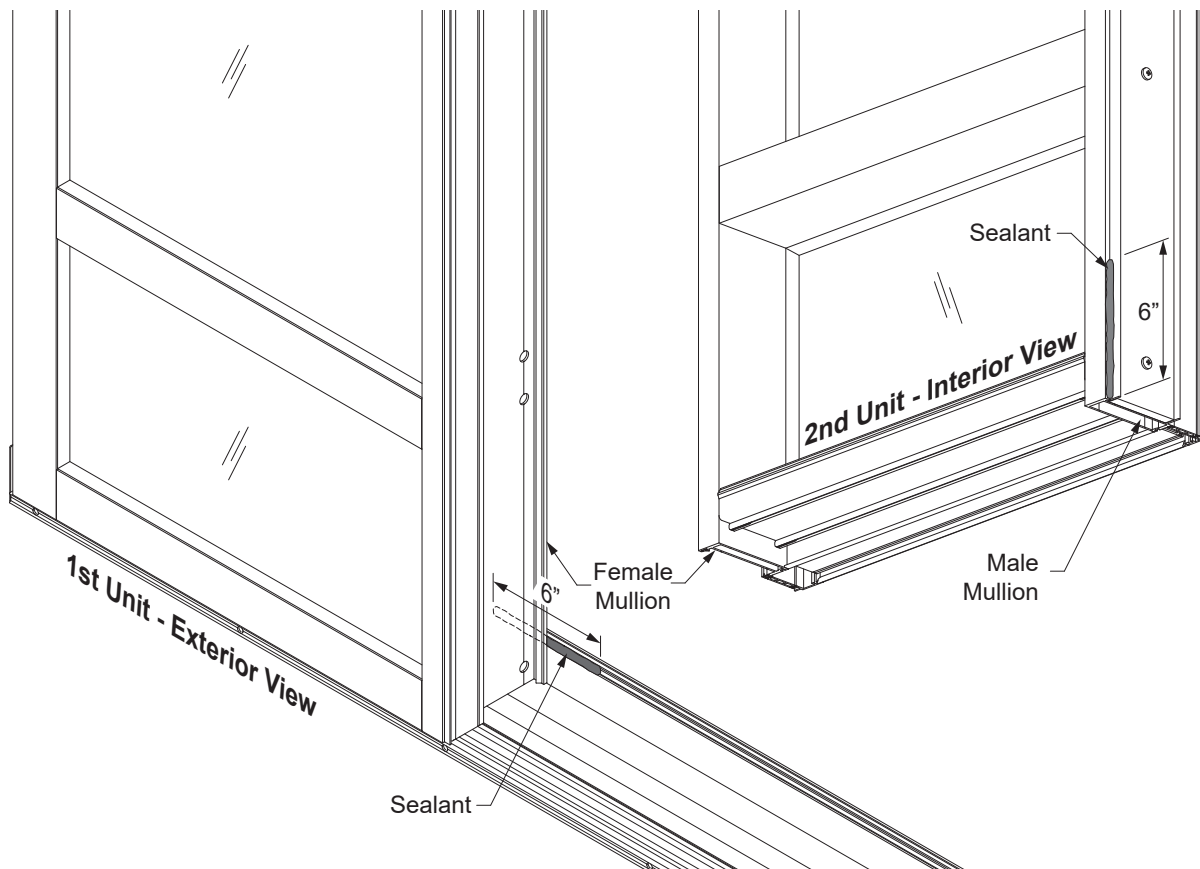

**Detail 71**

**FRAME INSTALLATION****STEP 30 (Continued)  
INSTALL FRAMES**

- Once the unit is set in place, use the holes in the back of the sill flashing to as pilot holes for 0.161” diameter tap holes in the sill. Fasten the sill into the back of the sill flashing with PC-1008 fasteners.
- Apply and tool sealant to both the fastener heads and the fastener threads at the back of the sill member.

See **Detail 72**.

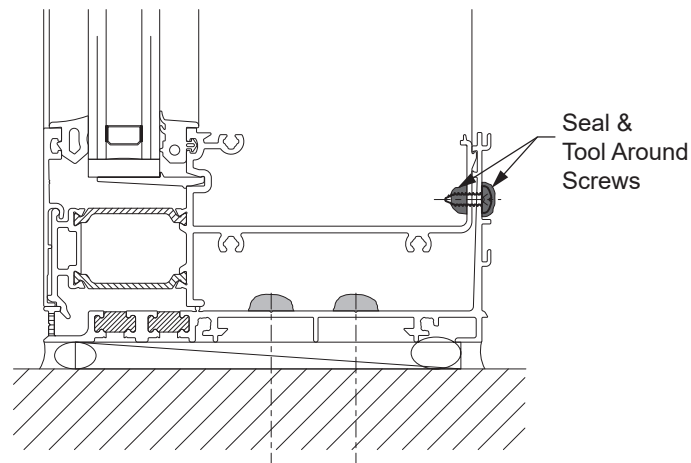

**Detail 72**



## FRAME INSTALLATION

### STEP 30 (Continued) INSTALL FRAMES

- Install the next framing unit, taking care to ensure that the unit is plumb, level, square, and true, and that the female mullion fully interfaces with the male mullion from the previous unit.
- Continue installation to the opposite jamb unit. Previously installed units can be moved (if not already fastened at the sill) to make room for the final unit.

See **Detail 73 & 73A**.

- Fill the void between the two units at the back of the sill flashing with sealant.

See **Detail 74**.

- Repeat **Step 30** until all units are installed.

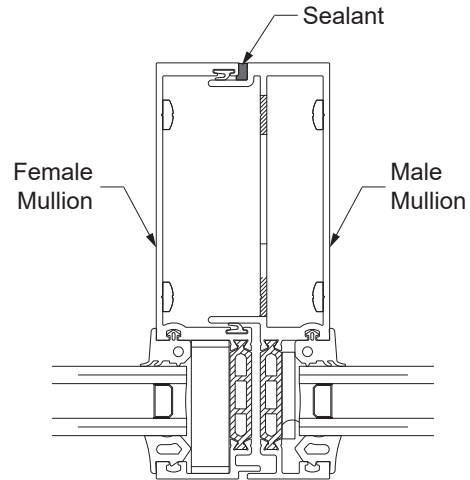

**Detail 73**

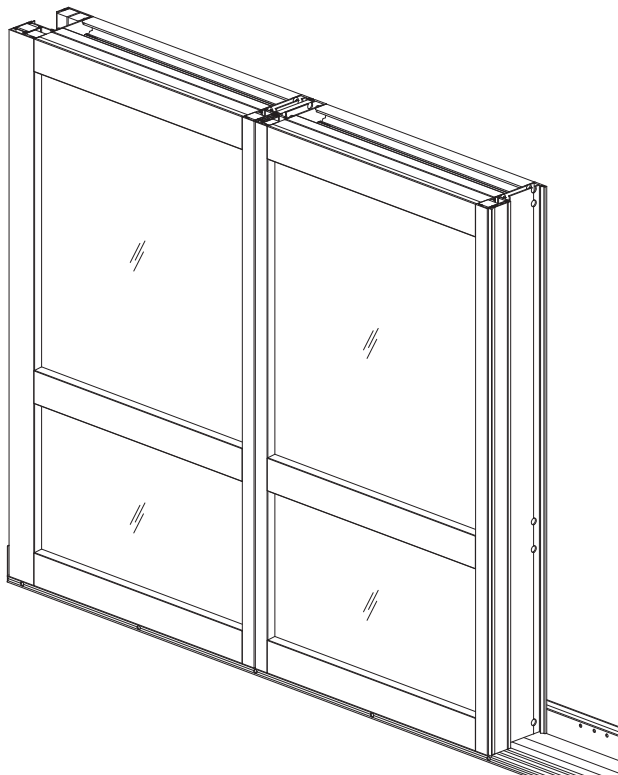

**Detail 73A**

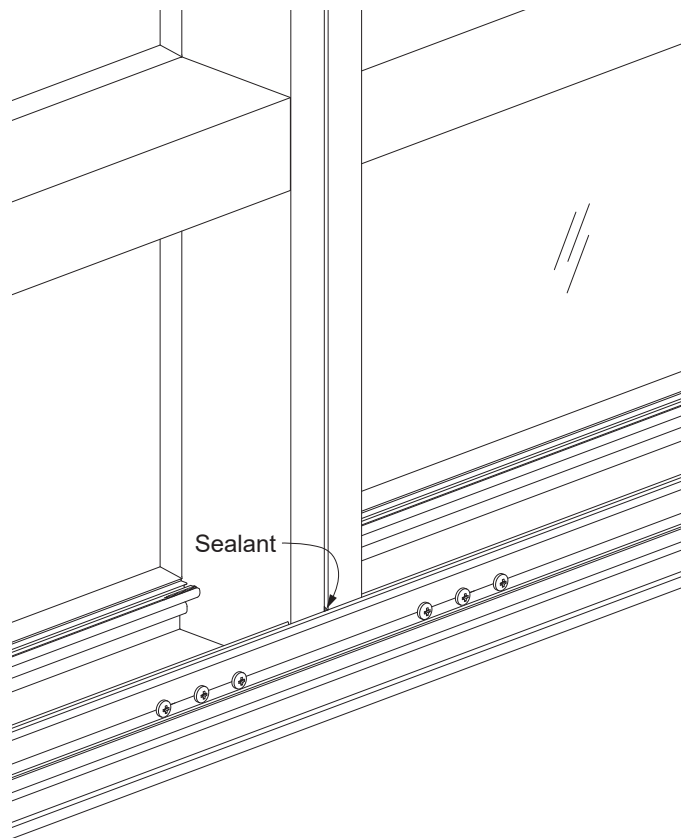

**Detail 74**

**FRAME INSTALLATION**

**STEP 31  
APPLY PERIMETER SEALANT**

- Once all the units are installed, apply perimeter sealant required on interior and exterior of the window wall system.
- Install backer rod around the perimeter of the frame.
- Apply perimeter sealant to the joint between the frame and the structure.
- Avoid getting sealant into the sill flashing weep holes.

See **Detail 75**.

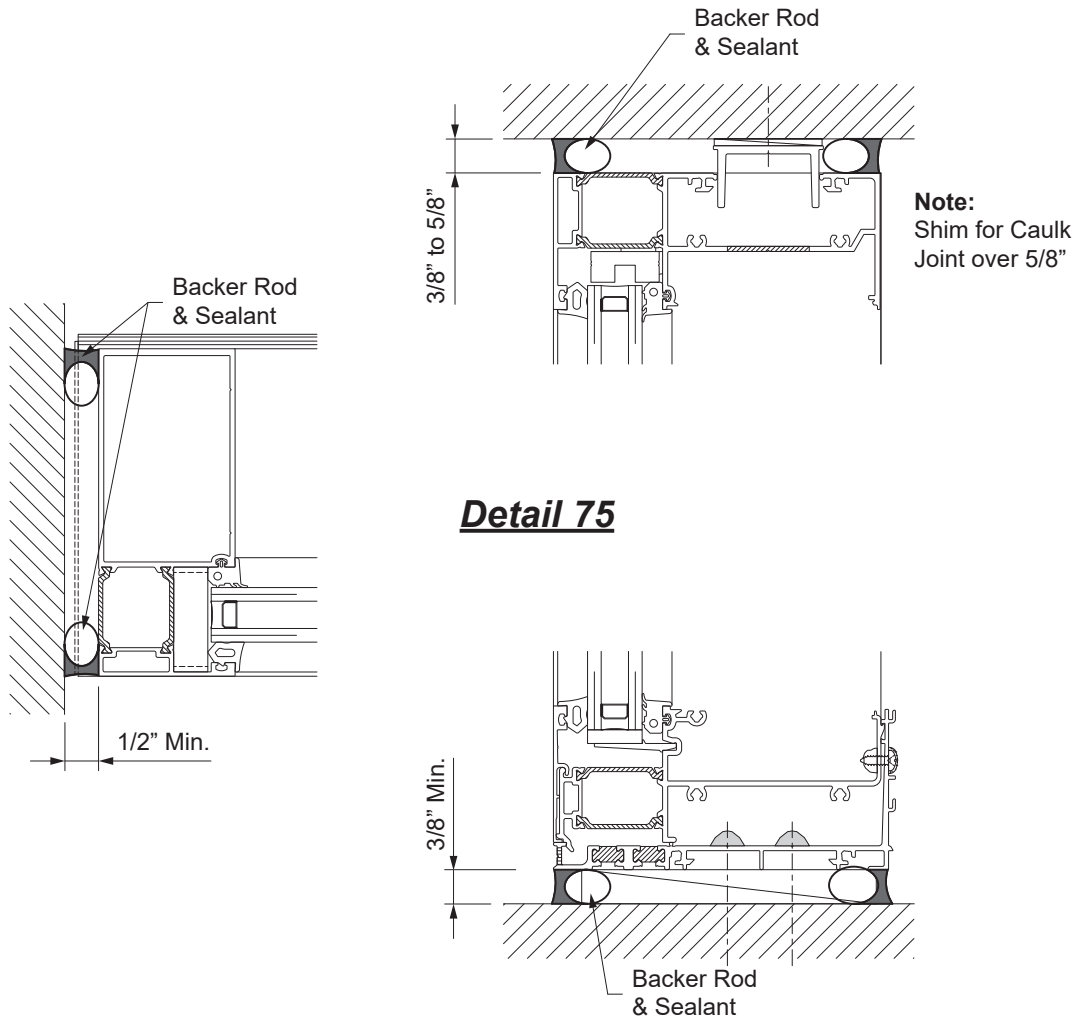

## FRAME INSTALLATION

### STEP 31A APPLY PERIMETER SEALANT AT SLAB EDGE COVERS

- For slab edge covers at the head and sill, install a backer rod and apply sealant to the back of the sill flashing and head receptor.
- Tool sealant prior to skinning over.
- Install a backer rod and seal the jamb edge of the slab edge covers.

See **Detail 76**.

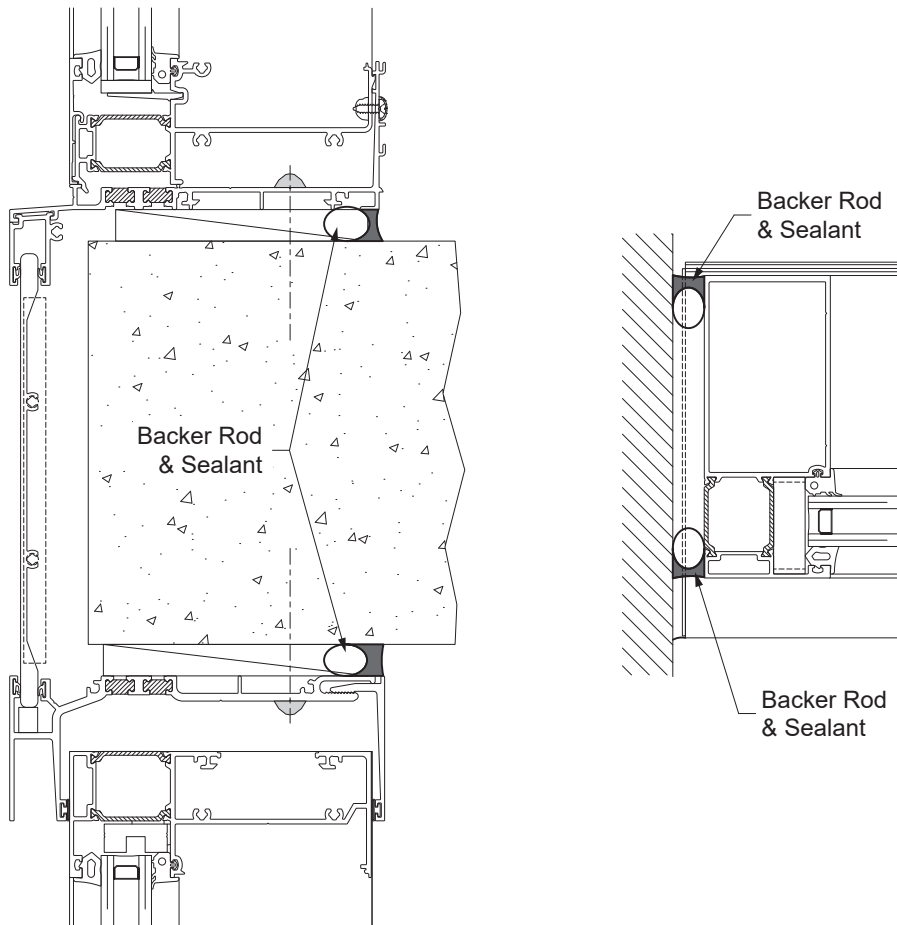

**Detail 76**

**FRAME INSTALLATION****STEP 32  
SEAL HEAD ANCHOR ACCESS HOLES**

**Note:** This is for only when E1-2830 channel anchors are used at the head.

-To plug the anchor access holes, apply sealant on the underside surface around the perimeter of the access hole. Then immediately insert the plug. Apply and tool sealant completely over and around the plug after inserting and seating in place.

See **Detail 77**.

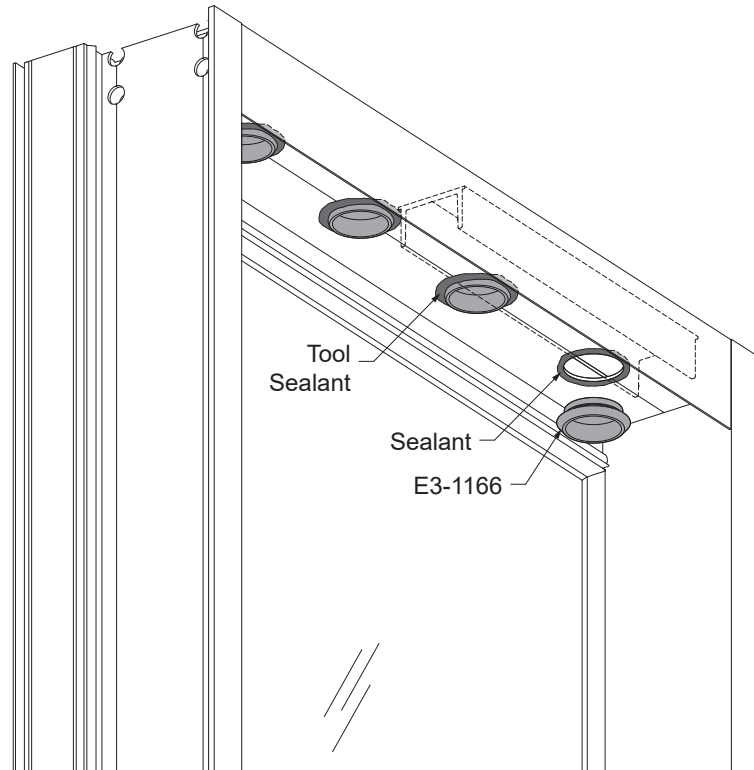

**Detail 77**

FRAME INSTALLATION

STEP 33  
APPLY SEALANT AT CORNER MULLIONS

-Apply backer rod and sealant the at the interior of the corner mullion, the full height of the mullion.  
Do not seal the exterior side.

See **Detail 78**.

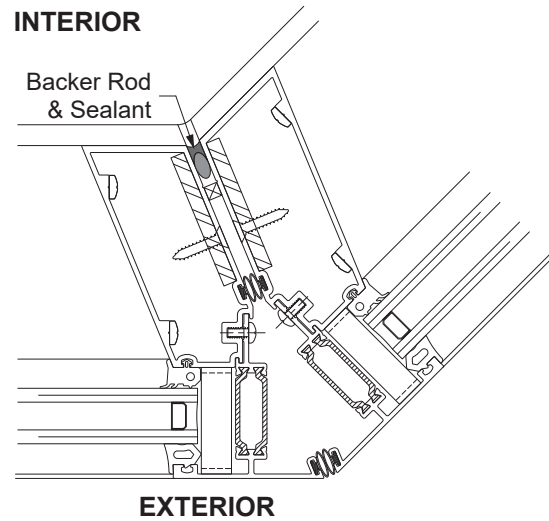
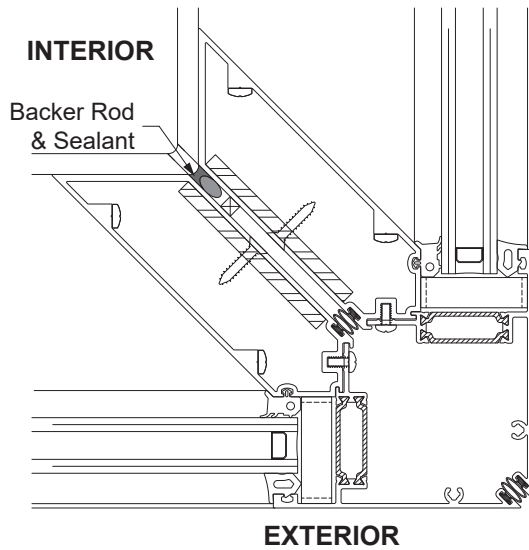

**Detail 78**

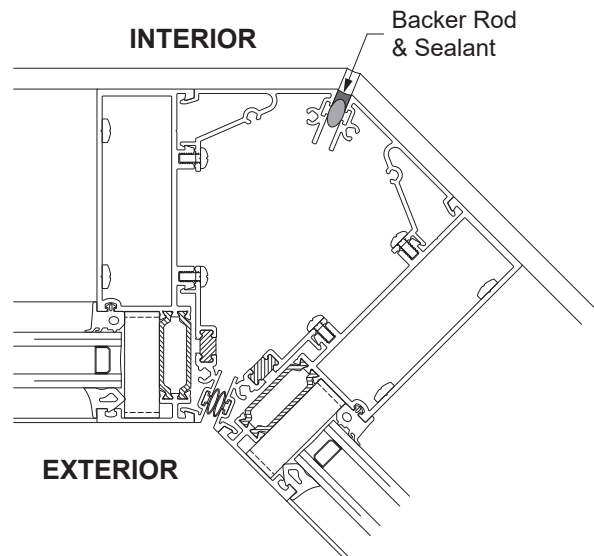
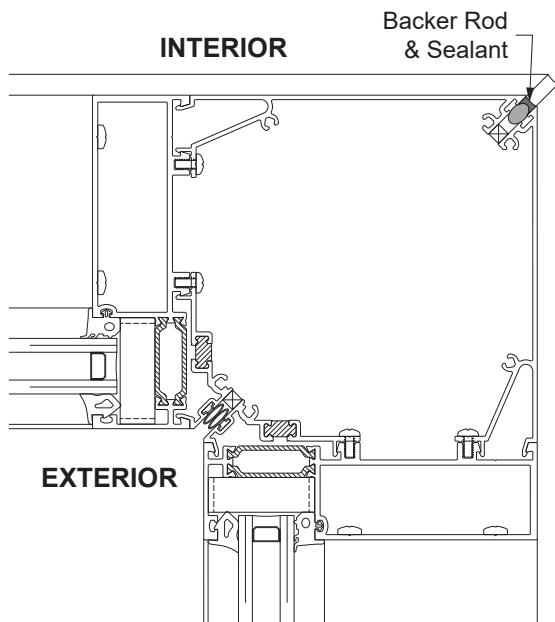

**FRAME INSTALLATION**

**STEP 34  
INSTALL INTERIOR COVERS**

- Immediately prior to installing the interior covers, apply continuous sealant to top of the sill at the sill flashing across the sill.
- Snap on the interior covers at the head, horizontals, and sills.

E9-6339 IG head & IG horizontals  
E9-6337 sill and OG head

- Snap on the E9-6342 face cover onto the interior of the sill flashing.

See **Detail 79**.

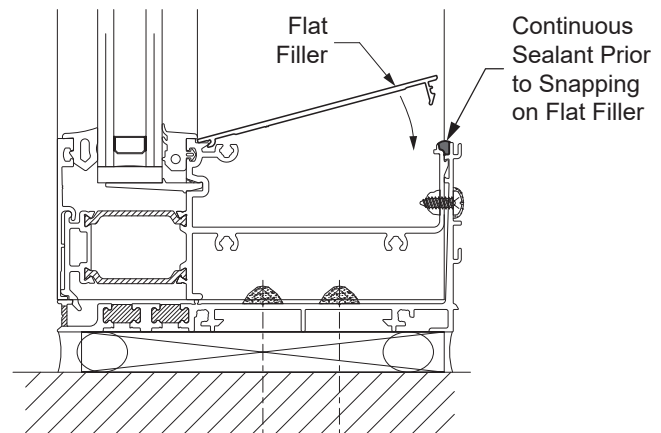
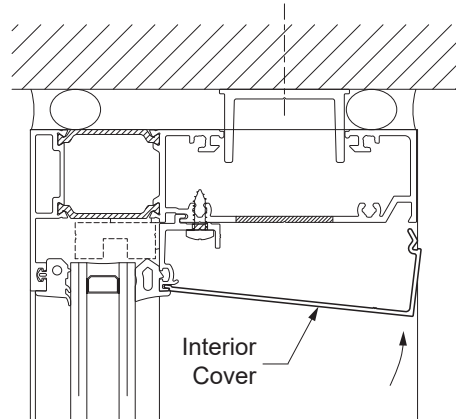

**Detail 79**

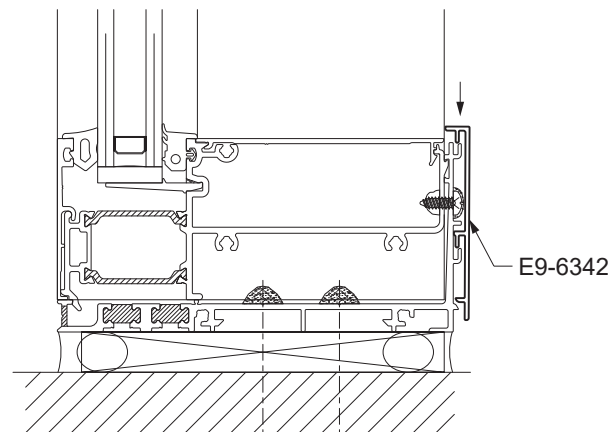

**DOOR FRAME INSTALLATION**

**STEP 35  
INSTALL DOOR FRAME**

Doors are shipped assembled, and door frames will be fabricated and shipped knocked down. Please refer to the 20D, 35D, & 50D **Entrances Installation Manual** for door installation.

-Door jamb mullions are made from the BE9-6306 male and BE9-6308 female mullions for the preglazed application, shimmed and fastened together as shown below in **Detail 81**. Spacing of fasteners to be determined by approved shop drawings and or P.E. calculations. Door transoms bars are made with tubular horizontals and BE9-6365 pocket filler (cut to transom horizontal length minus(-) 1/32") and E9-6338 glass stop.

-Join the mullion halves together with a 7/8" shim and FC-1236 fasteners located at 2" from the back of the mullion.

-Install the BE9-6365 flat filler (cut to length and notched as shown in **Detail 81**) into the door jamb mullions.

-Install the E9-6338 glass stop and flat filler onto the transom bar.

-Install E1-2826 sill flashing end dams into the ends of the sill flashing using the same method as previously shown in **Step 24 on Page 42**.

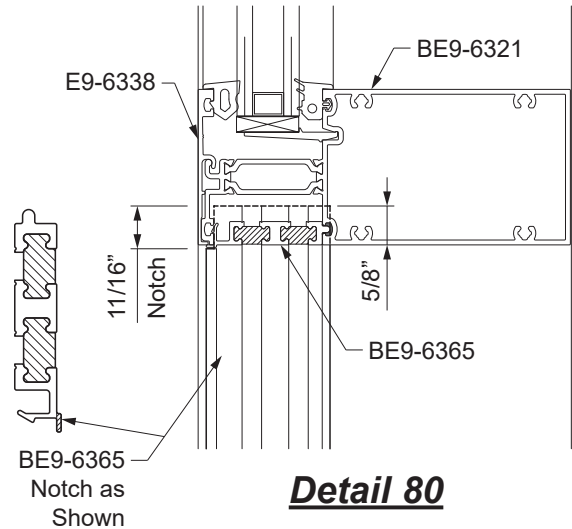

**Detail 80**

See **Detail 81**.

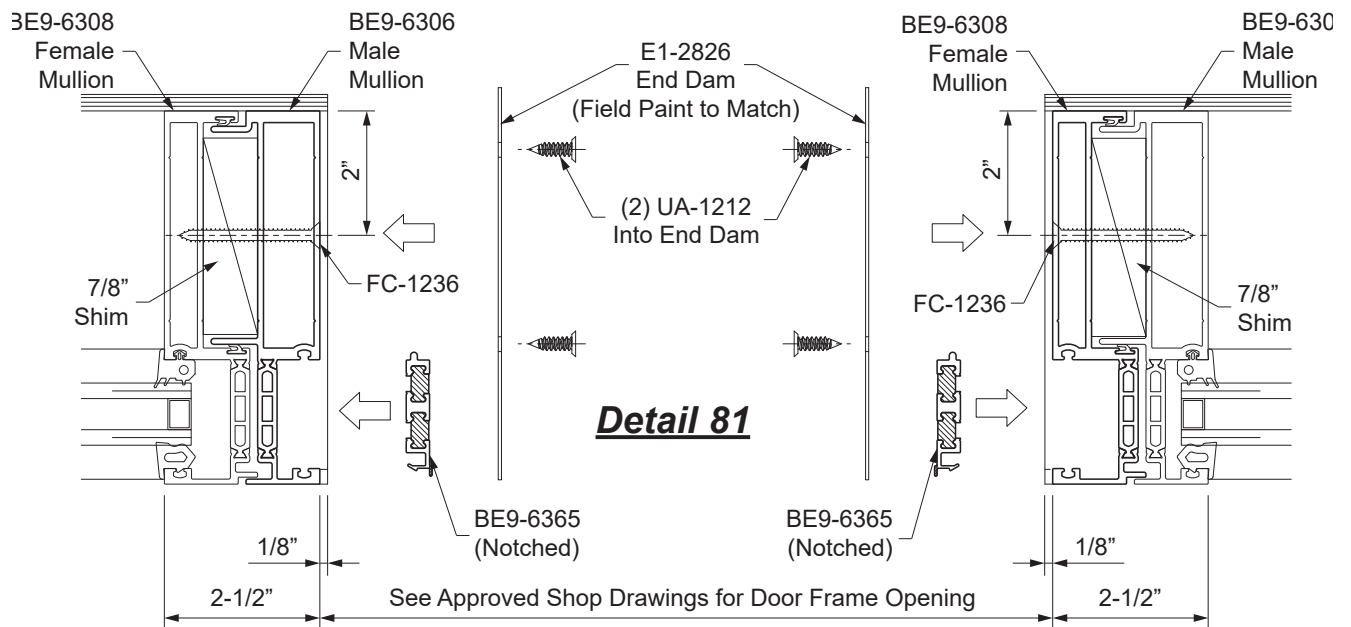

**Detail 81**

## DOOR FRAME INSTALLATION

### STEP 35 (Continued) INSTALL DOOR FRAME

- Assemble the door subframe and install the door jamb subframes to the door jambs with PC-1228 fasteners, spaced according to the approved shop drawings and or P.E. calculations. Provide a 3/8" shim space between the jamb subframes and the jamb mullions, 1/4" shim space at the transom bar. Maintain a 5/8" inset between the subframe and the front of the window wall framing.
- Snap in the door stops into the door jamb subframes.

See **Details 82 & 83**.

- Install backer rods between the subframes and the window wall framing, both front and back. Apply and tool sealant to the backer rods to ensure a water-tight seal.

\* **Note:** The 1-1/4" dimension is shown for when BE9-1526 jamb subframe is used. This dimension may vary if other subframes are used.

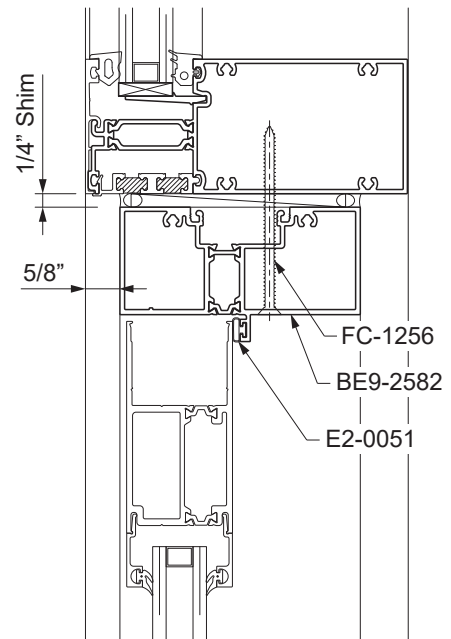

**Detail 82**

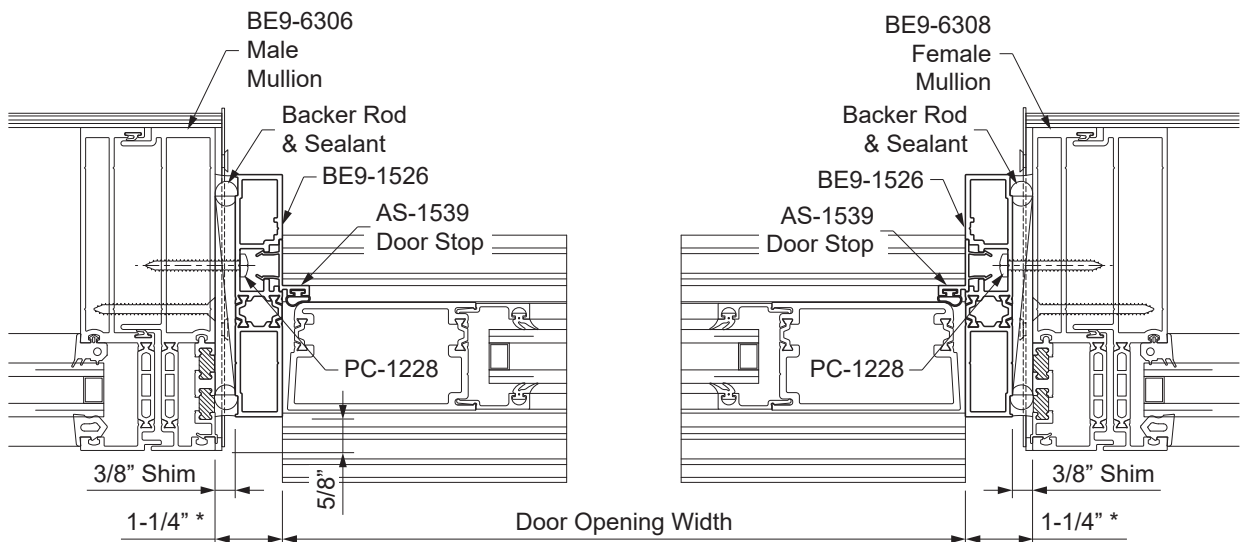

**Detail 83**



DOOR FRAME INSTALLATION

STEP 36  
GLAZE DOOR TRANSOM

See Details 84 & 85.

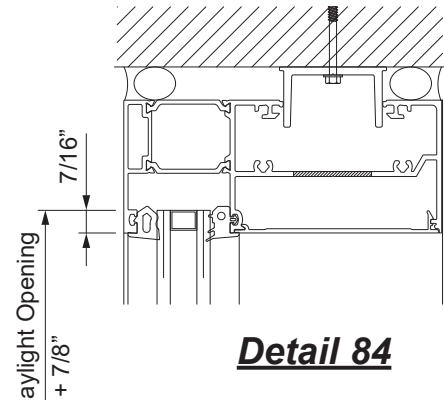

***Detail 84***

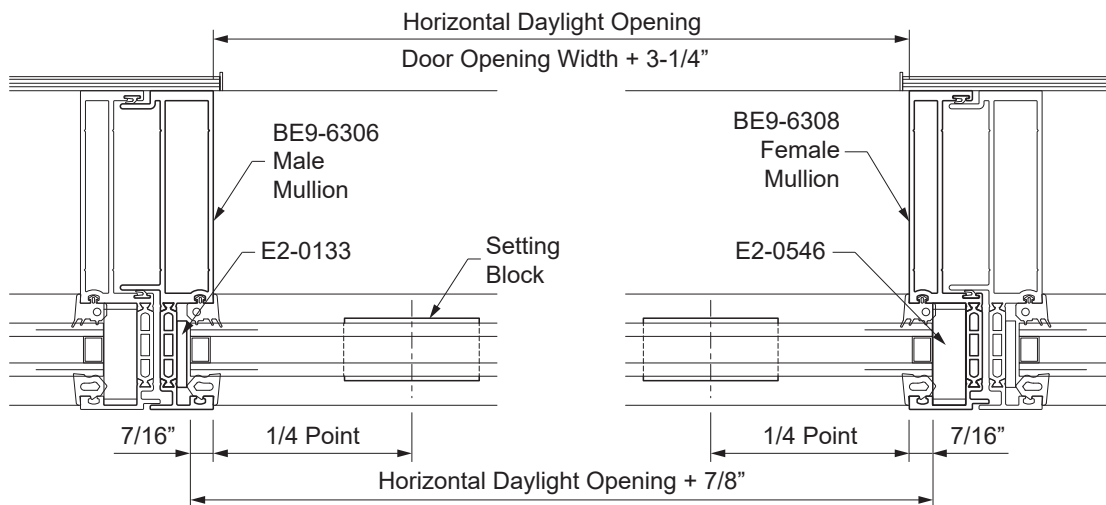
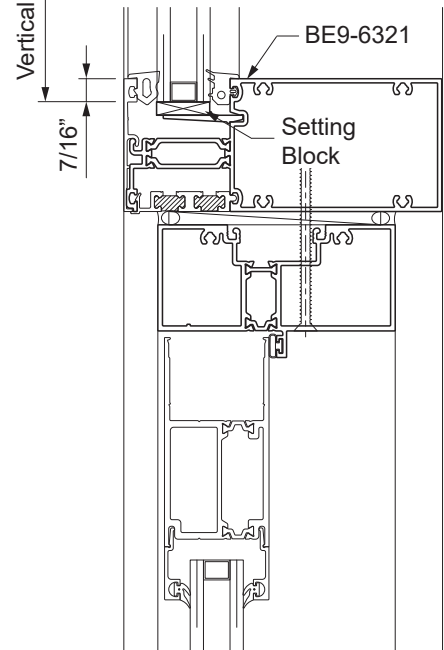

***Detail 85***

 **YKK AP America Inc.**

101 Marietta Street NW

Suite 2100

Atlanta, Georgia 30303

[www.ykkap.com](http://www.ykkap.com)