

YWW 60 XT Window Wall Installation Manual Preglazed SSG

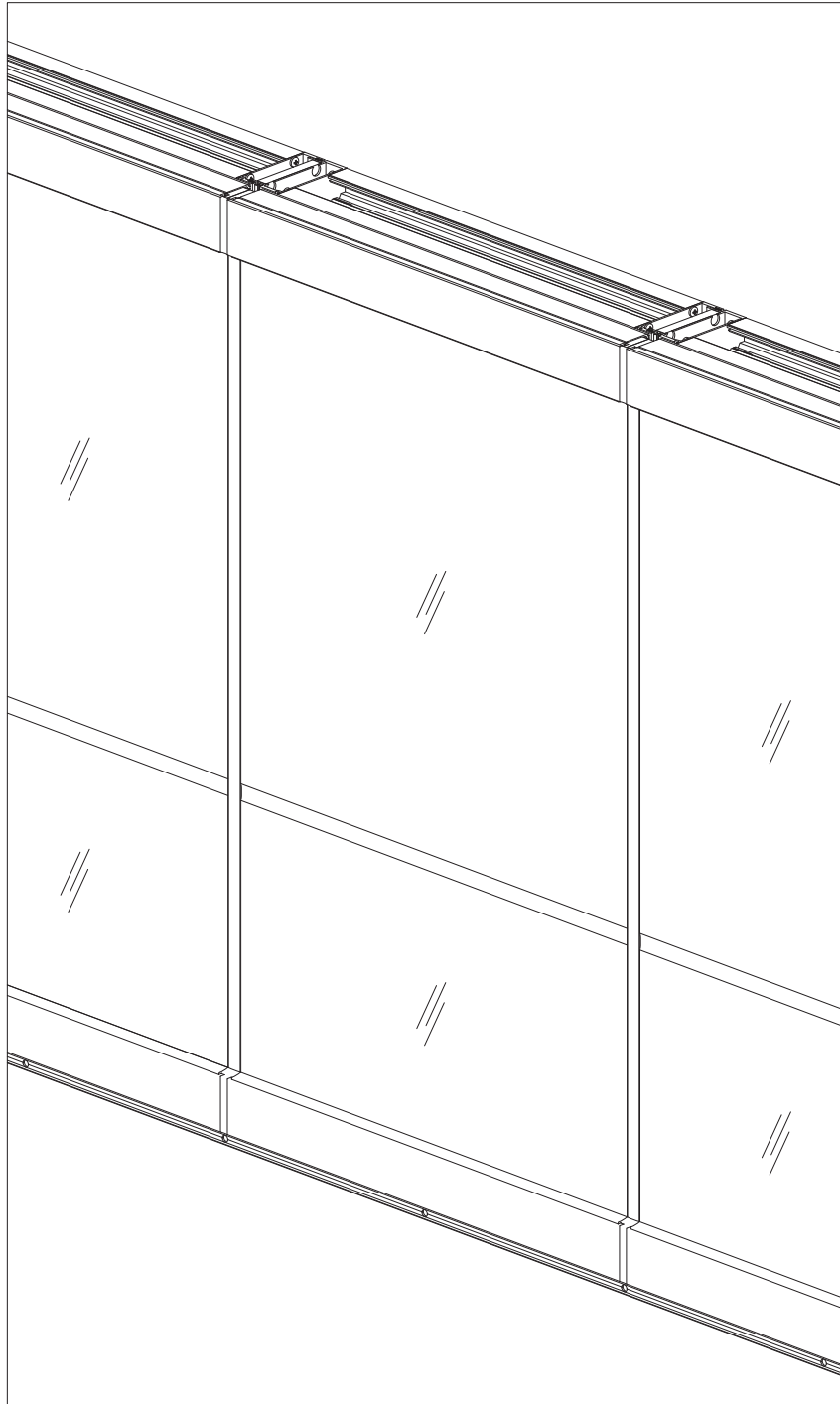

TABLE OF CONTENTS

Installation Notes.....	Page ii
Important Notice.....	Page iii
PARTS DESCRIPTION	
Framing Members.....	Pages 1 & 2
Accessories.....	Pages 3 to 4
Glazing Chart.....	Page 5
FRAME FABRICATION	
Determine Frame Size.....	Pages 6 & 7
Fabricate Vertical Members.....	Pages 8 to 10
Fabricate Horizontals.....	Pages 11 to 15
Fabricate Fillers & Glass Stops.....	Pages 16 to 18
Fabricate Sill Flashing & Flashing Face Cover.....	Page 19
Fabricate Slab Edge Plate Adaptor.....	Page 20
Fabricate Corner Adaptors.....	Page 20
Fabricate Head Receptors.....	Page 21
FRAME ASSEMBLY	
Assemble Frame.....	Pages 22 to 26
Install Steel Reinforcing (Optional).....	Page 27
Install Perimeter Fillers.....	Page 27
Install Weather Seal.....	Page 28
Install Foam Plugs at Head.....	Page 29
Install Exterior Glazing Gaskets.....	Pages 30 to 31
GLAZING	
Install Setting/Side Blocks.....	Page 32 & 33
Install Glass.....	Pages 34 to 36
Seal Glass to Frame.....	Page 37
Install Coner Adaptors.....	Page 38
Install Corner End Caps.....	Page 39
Install Setting Blocks for Intermediate Horizontals.....	Page 40
Install Glass Stops.....	Pages 41 & 42
Install SSG Rainscreen Gasket.....	Page 43
Install Exterior Wedge Gaskets.....	Pages 44 & 45
Seal Exposed Horizontal Cavities.....	Page 46
Apply Sealant at SSG Corner Exterior Glass Stops.....	Page 47
FRAME INSTALLATION	
Install Sill Flashing End Dams.....	Pages 48 & 49
Install Sill Flashing.....	Page 50
Install Flashing Splice Sleeve.....	Pages 51 & 51
Install Slab Edge Covers.....	Pages 52 to 58
Install Sill Flashing at Corners.....	Pages 59 & 60
Sill Preparation.....	Page 62
Install Frames.....	Pages 63 to 67
Apply Perimeter Sealant.....	Pages 68 & 69
Seal Head Anchor Access Holes.....	Page 70
Apply Sealant at Corner Mullions.....	Page 71
Install Interior Covers.....	Page 72
DOOR FRAME INSTALLATION	
Install Door Frame.....	Pages 73 & 74
Glaze Door Transom.....	Page 75

Installation Notes

1. Do not drop, roll or drag boxes of aluminum framing. Move and stack boxes with proper support to prevent distortion. If fork lifts are used, be especially careful about striking the boxes when lifting or moving.
2. Store in a dry, out of the way area. If rain exposure, condensation or any water contact is likely, then all packaging material should be removed. Wet packaging materials will discolor and may stain aluminum finishes and paints.
3. All materials should be checked for quality and quantity upon receipt, YKK AP must be notified immediately of any discrepancies in shipment. Check to make sure that you have the required shims, sealants, supplies and tools necessary for the installation.
4. Carefully check the openings and surrounding conditions that will receive your material. Remember, if the construction is not per the construction documents, it is your responsibility to notify the general contractor in writing. Any discrepancies must be brought to the general contractor's attention before you proceed with the installation.
5. Gather your shop drawings, materials, packing list, and this installation manual. Carefully review parts location, the sequence it goes therein, when you glaze it and how you seal it. Installation instructions are of a general nature and may not cover every condition you will encounter. The shop drawings and/or installation manuals were prepared specifically for the product.
6. Any material substitutions must be of equal or greater quality.
7. Make certain that material samples have been sent for compatibility testing for all manufacturer's sealants involved. Make certain sealants have been installed in strict accordance with the manufacturer's recommendations and specifications.
8. Remember to isolate, in an approved manner, all aluminum from uncured masonry or other incompatible materials.
9. System-to-structure fasteners are not supplied by YKK AP. Fasteners called out on shop drawings are to indicate minimum sizes for design loading.
10. If any questions arise concerning YKK AP products or their installation, contact YKK AP for clarification before proceeding.
11. YKK AP storefront and/or curtain wall framing is typically completed before drywall, flooring and other products which may still be in process. Take the extra time to wrap and protect the work produced.
12. Cutting tolerances are plus zero, minus one thirty second unless otherwise noted.
13. Check our website, www.ykkap.com, for the latest installation manual update prior to commencing work.

Important Notice for SSG Window Wall Systems:

In order to properly perform and to maintain structural integrity, in addition to all other installation requirements, structurally glazed window wall systems rely specifically upon effective and appropriate structural sealant selection and installation.

It is the responsibility of the glazing contractor to take all steps to ensure the installed structural sealant is capable of meeting all applicable project requirements in accordance with industry standards. Such steps on each project may include, but are not limited to, design reviews, formal adhesion testing, project specification compliance, validating applications, field testing, auditing, sealant design strength analysis, and the quality control review of the installation and surrounding conditions.













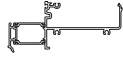







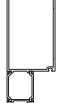

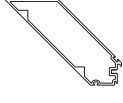
Subject to project specific design pressures, requirements, and/or specifications, the structural sealant that is used between the glass and framing system must be capable of withstanding tensile and shear stresses imposed by the window wall without failing adhesively or cohesively.

The structural sealant's capability to withstand these stresses are dependent on several factors including, but not limited to, type of structural sealant, method of application (i.e. cleaning, primer), construction of glazing material (i.e. insulating glass unit (IGU), other infill, and finish of framing (i.e. anodizing, paint).













- Adhesive failure occurs when sealant pulls away from substrate cleanly, leaving no sealant material behind.
- Cohesive failure occurs when sealant breaks or tears within itself but does not separate from each substrate because sealant-to-substrate bond strength exceeds sealant's internal strength.

The IGU and/or other infill must be constructed for installation into structurally sealant glazed window walls. Notify the manufacturer or fabricator of the IGU and/or infill and advise of the product's application into 2 or 4-sided structurally sealant glazed window walls along with the project's design requirements so that appropriate fabrication steps are taken.

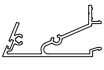
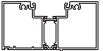
YWW 60 XT FRAMING MEMBERS

	Male Mullion Used with BE9-6306 Mullion	BE9-6303		SSG Horizontal	E9-6356
	Female Mullion Used with BE9-6303 & BE9-6308 Mullion	BE9-6306		Sill (IG/OG)	BE9-6327
	Female Tubular Mullion Used with BE9-6306 Mullion	BE9-6308		Sill Flashing	BE9-6328
	Female SSG Mullion Used with E9-6355	E9-6354		Sill Flashing for Slab Edge	BE9-6330
	Male SSG Mullion Used with E9-6354	E9-6355		Head Receptor	BE9-6329
	Jamb 2-1/2" x 6"	BE9-6311		Head Receptor w/ Plate Adaptor	BE9-6331
	Tubular Jamb 2-1/2" x 6"	BE9-6313		Receptor Snap Cover Used with BE9-6329 & BE9-6331	E9-6343
	90° Corner Mullion Half 2-1/4" x 6"	E9-6344		Flashing Interior Face Cover Used with BE9-6328 & BE9-6330	E9-6342
	135° Corner Mullion Half 2-1/4" x 6"	E9-6345		Optional Sill Flashing Interior Face Cover Used with BE9-6328 & BE9-6330	E9-6346
	Head (OG) 2-1/2" x 6"	BE9-6367		90° Corner Adaptor For 1" Glazing	BE9-6357
	Optional Head (IG/OG) 2-1/2" x 6"	BE9-6318		90° Corner Adaptor For 1-5/16" Glazing	BE9-6363
	Horizontal (OG)	BE9-6321		135° Corner Adaptor For 1" Glazing	BE9-6358

YWW 60 XT FRAMING MEMBERS (Continued)







	135° Corner Adaptor For 1-5/16" Glazing	BE9-6364		6-5/8" Slab Edge Cover	E9-7723
	Corner Mullion	BE9-6374		7-3/8" Slab Edge Cover	E9-8223
	90° Inside Corner Adaptor	BE9-6375		7-7/8" Slab Edge Cover	E9-8231
	135° Inside Corner Adaptor	BE9-6376		8" Slab Edge Cover	E9-8589
	90° Corner Cover (Large)	E9-2740		9" Slab Edge Cover	E9-8428
	135° Corner Cover (Large)	E9-2742		Anchor	E9-6340
	Interior Cover	E9-6339		4-1/2" x 2-1/4" Door Head For 35XT/50XT Doors* E2-0051 Not Included	BE9-1532
	Flush Filler	E9-6337		Door Jamb Adaptor For 35XT/50XT Doors* E2-0051 Not Included Use with BE9-1540	BE9-1533
	Glass Stop	E9-7852		Narrow Door Jamb For 35XT/50XT Doors* Use with BE9-1533	BE9-1540
	Exterior Glass Stop	E9-6338		Flat Filler	BE9-6365
	Aluminum Plate Adaptor For BE9-6330	E9-8222		Single Acting Transom Bar For 25T/35T/50T Doors E2-0051 Not Included	BE9-2582
	6-1/8" Slab Edge Cover	E9-8059		Door Jamb Flat Subframe For 25T/35T/50T Doors Use with AS-1539	BE9-1526

*Note: 35XT/50XT Doors to be discontinued after April 30, 2024.

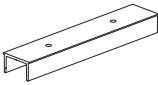
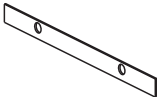
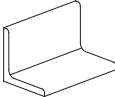
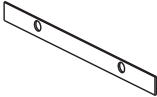
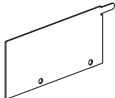
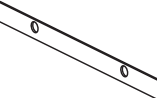
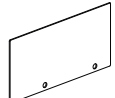
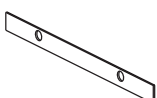
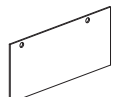
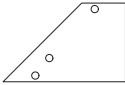
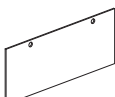
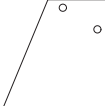



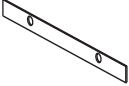
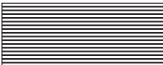
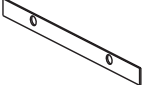







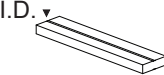
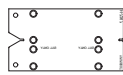

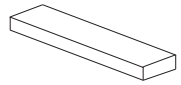

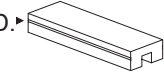



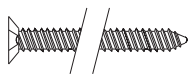

YWW 60 XT FRAMING MEMBERS (Continued)

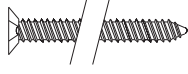
	<p>Door Stop For 25T/35T/50T Doors E2-0051 Included Use with BE9-1526</p>	<p>AS-1539</p>	
---	--	-----------------------	--

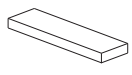
ACCESSORIES

	<p>Head Anchor 10" Cut Length</p>	<p>E1-2830</p>	 <p>End Cap For E9-8223 Slab Edge Cover Plate</p>	<p>E1-9953</p>
	<p>Door Jamb Mullion Anchor (3-1/2")</p>	<p>E1-2819</p>	 <p>End Cap For E9-8231 Slab Edge Cover Plate</p>	<p>E1-9954</p>
	<p>End Dam For Sill Flashing</p>	<p>E1-2820</p>	 <p>End Cap For E9-8589 Slab Edge Cover Plate</p>	<p>E1-9955</p>
	<p>End Dam For Sill Flashing @ Door Jamb</p>	<p>E1-2616</p>	 <p>End Cap For E9-8428 Slab Edge Cover Plate</p>	<p>E1-9956</p>
	<p>End Cap For BE9-6329 Head Receptor</p>	<p>E1-2821</p>	 <p>90° Corner Half End Cap</p>	<p>E1-2824</p>
	<p>End Cap For BE9-6331 Slab Edge Head Receptor</p>	<p>E1-2822</p>	 <p>135° Corner Half End Cap</p>	<p>E9-2825</p>
	<p>End Cap For BE9-6331 Slab Edge Head Receptor Splice</p>	<p>E1-2823</p>	 <p>PVC Jamb Back Filler</p>	<p>E3-3667</p>
	<p>End Cap For Slab Edge Sill Flashing Adaptor</p>	<p>E1-1196</p>	 <p>Head Receptor Splice Sleeve For Slab Edge</p>	<p>E1-9961</p>
	<p>End Cap For E9-8059 Slab Edge Cover Plate</p>	<p>E1-9984</p>	 <p>Silicone Splice Sleeve</p>	<p>E2-0070</p>
	<p>End Cap For E9-7723 Slab Edge Cover Plate</p>	<p>E1-9985</p>	 <p>Setting Block Chair For 1" Glazing</p>	<p>E1-2831</p>

ACCESSORIES

	Setting Block Chair For 1-5/16" Glazing	E1-2833		Weep Baffle	E2-0099
	Setting Block For 1" Glazing @ SSG Horizontal	E2-0561		Drill Fixture	H-7267
	Setting Block For 1" Glazing @ Captured Horizontals	E2-0704 PC		Drill Fixture For 90° Corner Mullion	H-7268
	SSG Setting Block For 1-5/16" Glazing	E2-9611S		#10" x 3/8" PHMS Stainless Steel, For Corner Cover Attachment	PM-1006 -SS
	Setting Block For Top of Glass	E2-0068		#10 x 3/8" PHSMS Type AB Stainless Steel, For Sill Flashing Attachment	PC-1008 -SS
	Setting Block For Slab Edge Cover	E2-0054		#12 x 3/4" UFHMS Type A , Zinc Plated Steel, For End Dam Attachment	UA-1212
	Water Deflector	E2-0049		#12 x 1-3/4" FHSMS Type AB , Zinc Plated Steel, For Corner Frame Assembly	PC-1228
	1-1/2" Air Seal Plug	E3-1166		#12 x 2-1/4" FHSMS Type AB , Zinc Plated Steel, Used at Door Jamb	FC-1236
	Foam Backer Tape 1" x 1-1/4" (Roll)	E2-0259		#12 x 3-1/2" FHSMS Type AB , Zinc Plated Steel, Used at Door Transom Bar	FC-1256
	1/4" x 1/4" Spacer Tape	E2-0110		#10 x 3/8" FHSMS Type AB For Corner End Cap Installation	FC-1006
	Side Block For Male Mullion	E2-0133		#12 x 1" FHSMS Type AB , Used with Jamb Strap Anchor	FC-1216
	Airtight Gasket	E2-0051		#12 x 5/8" PHSMS Type AB , Zinc Plated Steel	PC-1210
	Weathering Gasket	E2-0065		#12 x 1-1/4" PHSMS Type AB , Zinc Plated Steel	PC-1220

See Glazing Chart on Page 6 for Gasket Configurations.

GLAZING CHART

1" Insulating Glass			1-5/16" Laminated Insulating Glass		
<p>Captured SSG</p>			<p>Captured SSG</p>		
<p>Interior Gasket (Captured)</p>	<p>◀ I.D.</p>	<p>E2-0812 Dart Gasket (SCR) 3/8" F.C.</p>	<p>Interior Gasket (Captured)</p>		<p>E2-0541 Dart Gasket (SCR) 1/4" F.C.</p>
<p>Exterior Gasket (Captured)</p>	<p>◀ I.D.</p>	<p>E2-0819 Wedge Gasket (SCR) 3/8" F.C.</p>	<p>Exterior Gasket (Captured)</p>	<p>◀ I.D.</p>	<p>E2-0815 Wedge Gasket (SCR) 3/16" F.C.</p>
<p>SSG Spacer</p>		<p>E2-0550 SSG Spacer (SCR) For SSG Verticals and Horizontals</p>	<p>SSG Spacer</p>		<p>E2-0544 SSG Spacer (SCR) For SSG Verticals and Horizontals</p>
<p>SSG Rainscreen</p>	<p>I.D.</p>	<p>E2-0549 SSG Rainscreen Gasket (Silicone)</p>	<p>SSG Rainscreen</p>	<p>I.D.</p>	<p>E2-0551 SSG Rainscreen Gasket (Silicone)</p>

FRAME FABRICATION

STEP 1 DETERMINE FRAME SIZE

Determine Frame Width:

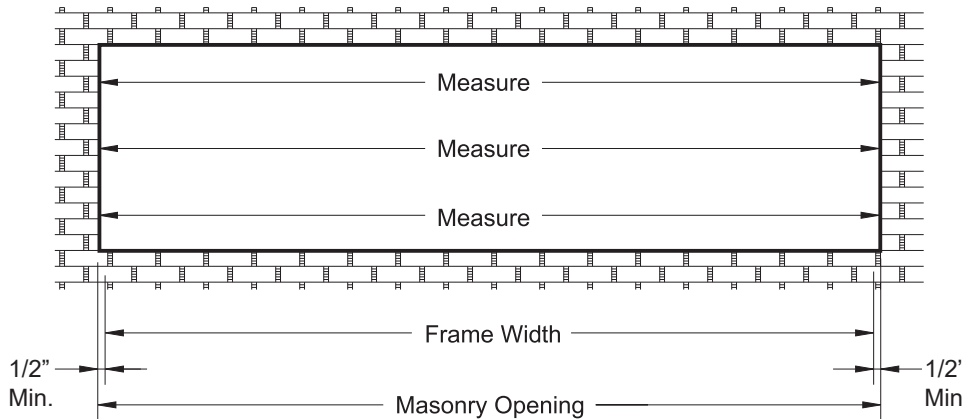

Note: Check opening for squareness of plumb at both ends, units must be installed in a true rectangle.

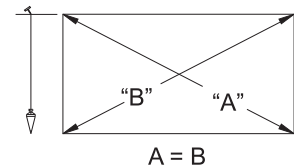

DETAIL 1

- Measure the width of the masonry opening at the top, middle, and bottom.
 - Select the smallest dimension measured and subtract 1" to determine the frame width.
- See **Detail 1**.

Note: For additional possibilities such as slab edge cover application, it is recommended to increase the caulk joint at the jambs to facilitate installation of the last framed unit. (Unit width will proportionally affect caulk joint width.)

Determine Frame Height for Non-Head Receptor Conditions:

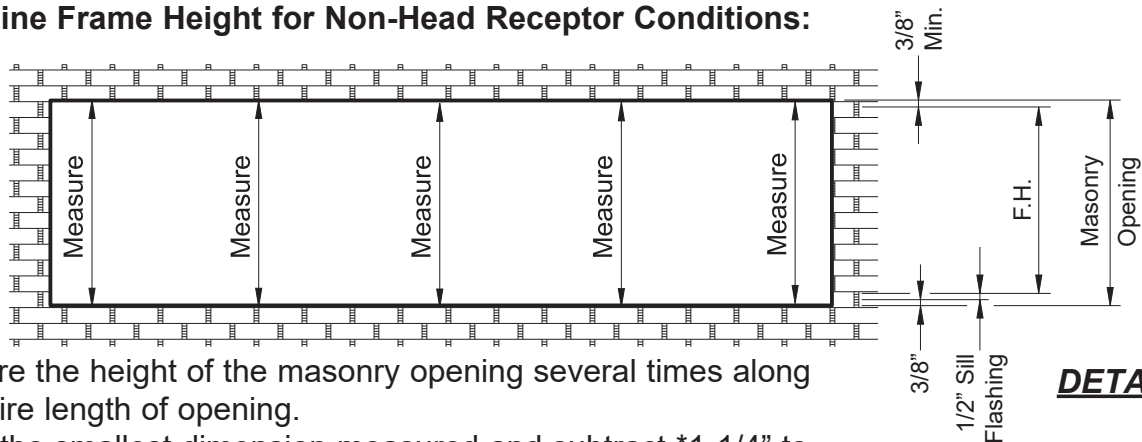

DETAIL 2

- Measure the height of the masonry opening several times along the entire length of opening.
- Select the smallest dimension measured and subtract *1-1/4" to determine the frame height to be used.

Minimum of 3/8" shim/caulk joint at the head.

1/2" for the sill flashing.

Minimum 3/8" shim/caulk joint below the sill flashing.

See **Detail 2**.

* **Note:** 1-1/4" is based on 3/8" perimeter caulk joint, without use of head receptor, which can vary per project.

FRAME FABRICATION

STEP 1 (Continued)
DETERMINE FRAME SIZE

Determine Frame Height for Slab Edge Cover Conditions:

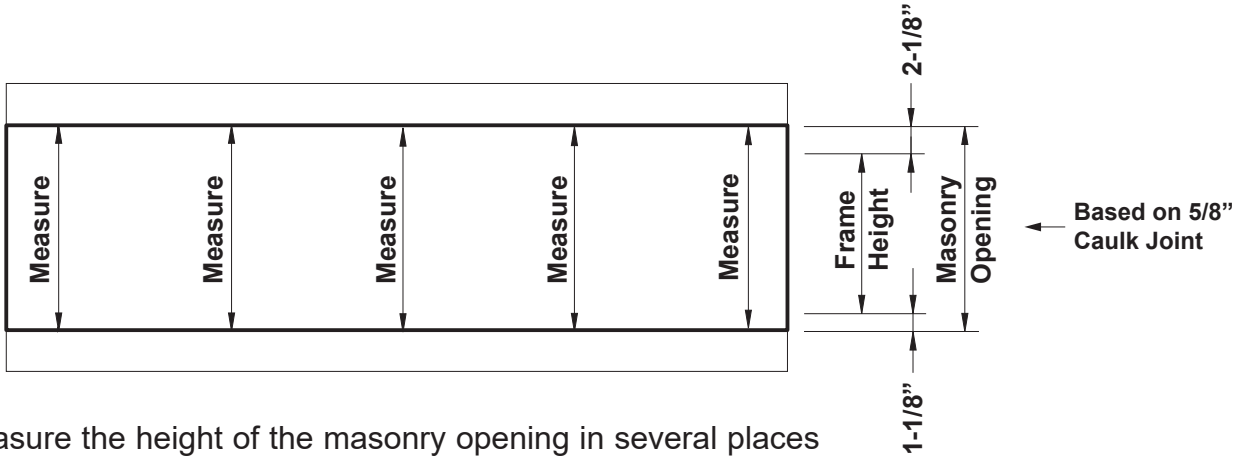

- Measure the height of the masonry opening in several places along the entire length of the opening.
- Select the smallest dimension measured and subtract *3-1/4" to determine the frame height to be used:
 - 5/8" for the shim/caulk joint at the head.
 - 5/8" for the shim/caulk joint below the sill flashing.

See **Detail 3**.

* **Note:** 3-1/4" is based on 5/8" perimeter caulk joint, which can vary per project.

Detail 3

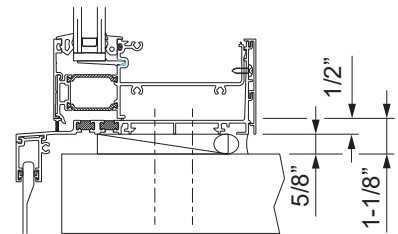
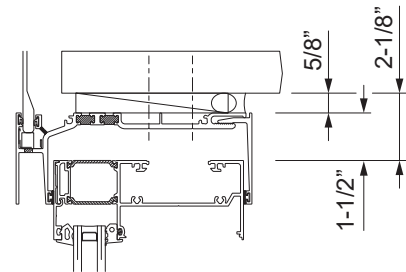

FRAME FABRICATION

**STEP 2
FABRICATE VERTICAL MEMBERS**

- Cut all jamb and two piece vertical members to the frame height determined in **Step 1**.
- Fabricate holes in the vertical members for screw spline attachment using one of the methods below:
 - Using the H-7267 drill fixture as a template, line up the glazing pockets and mark hole locations through the screw splines of the templates.
 - OR**
 - Layout hole locations on vertical members as shown in **Detail 4**.
- Drill 0.236" diameter (#B drill bit) holes at each location marked.

Notes: Additional fabrication will be required for the inclusion of steel reinforcing. Drill fixture plate can be used.

* A Ø5/16" access holes can be used at the top to eliminate sharp edges.

** Access holes at top of the mullions will have sharp edges.

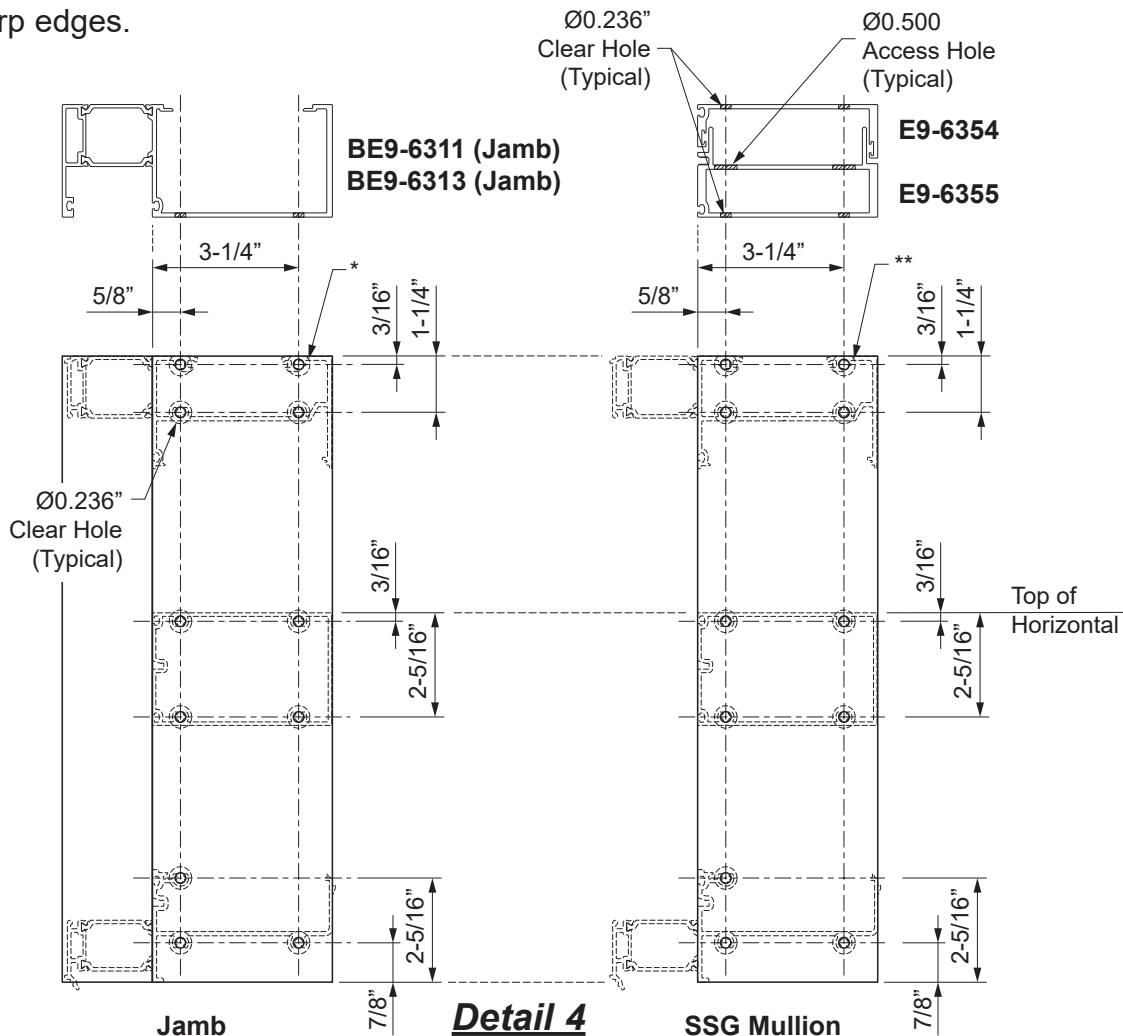

FRAME FABRICATION

STEP 2 (Continued)
FABRICATE VERTICAL MEMBERS

To fabricate the clear holes for the 90° corner mullion half or 135° corner mullion half, the following procedure is recommended, if you don't have a suitable drill fixture.

- Cut a mitered piece of the head, horizontal, or sill and clamp it onto the mullion where the appropriate horizontal is intended to meet the corner mullion.
- Using a 0.236" drill bit, drill through the screw splines of the mitered piece into the corner mullion. The hole should align with the v-groove in the corner mullion.

See **Detail 5**.

Note: For 90° corner mullion, an H-7268 drill fixture can also be used.

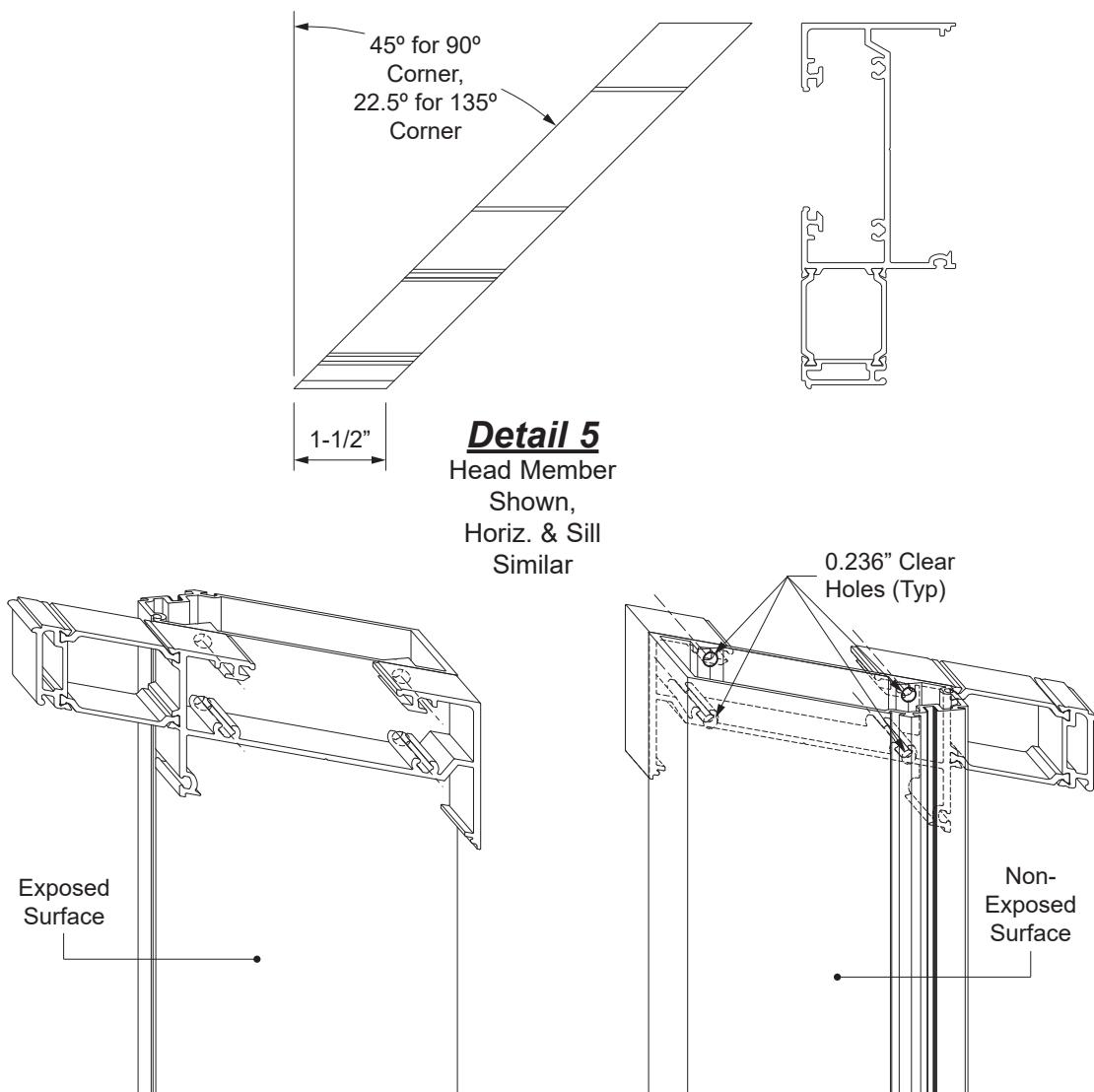

FRAME FABRICATION

**STEP 2 (Continued)
FABRICATE VERTICAL MEMBERS**

-Corner mullion halves also require a 0.500" diameter access holes are required at the screw spline and a 0.750" access holes are required at the interior hollow as shown in **Detail 6**.

* **Note:** Access holes at top of the mullions will have sharp edges.

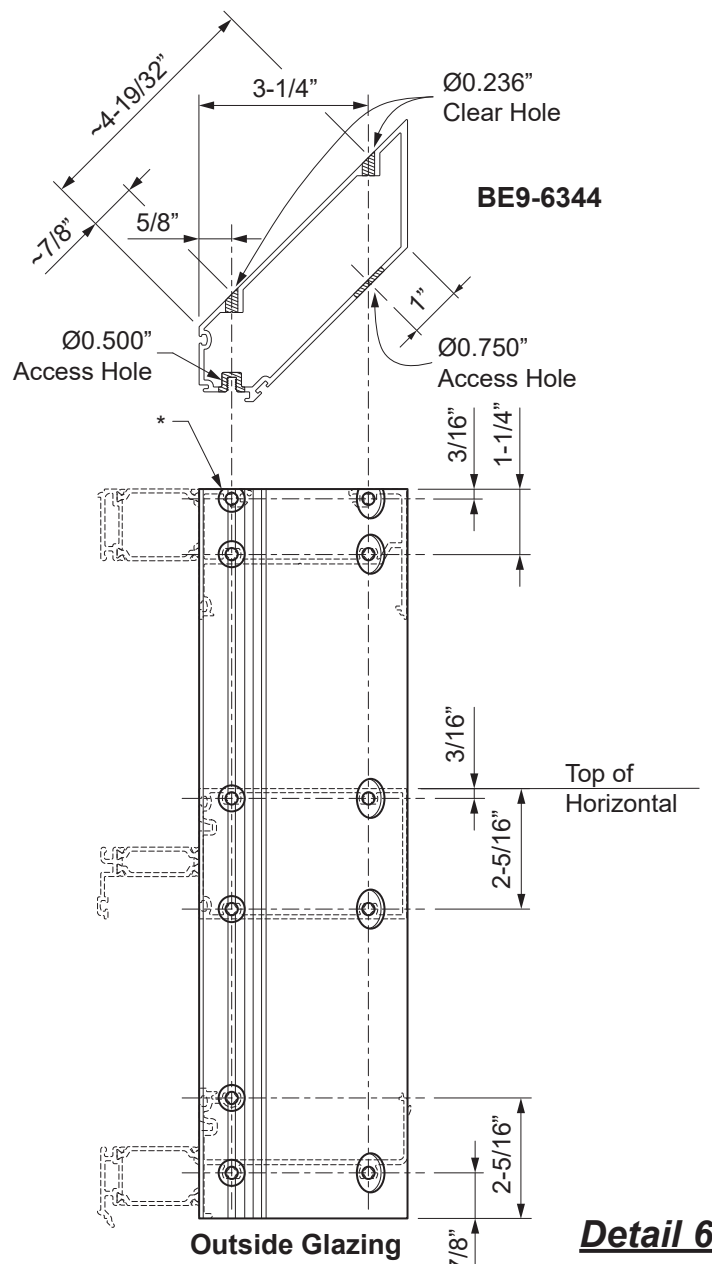

FRAME FABRICATION

STEP 3
FABRICATE HORIZONTALS

- Cut all head and sill members to the horizontal daylight opening plus(+) the numbers as shown in **Details 7 thru 12**.
- Optional head member (BE9-6318) will require $\varnothing 0.189"$ tap holes as shown in **Details 8 & 11**.

Note: Sill members at SSG mullions are notched differently from head members and captured horizontals to allow water to drain.

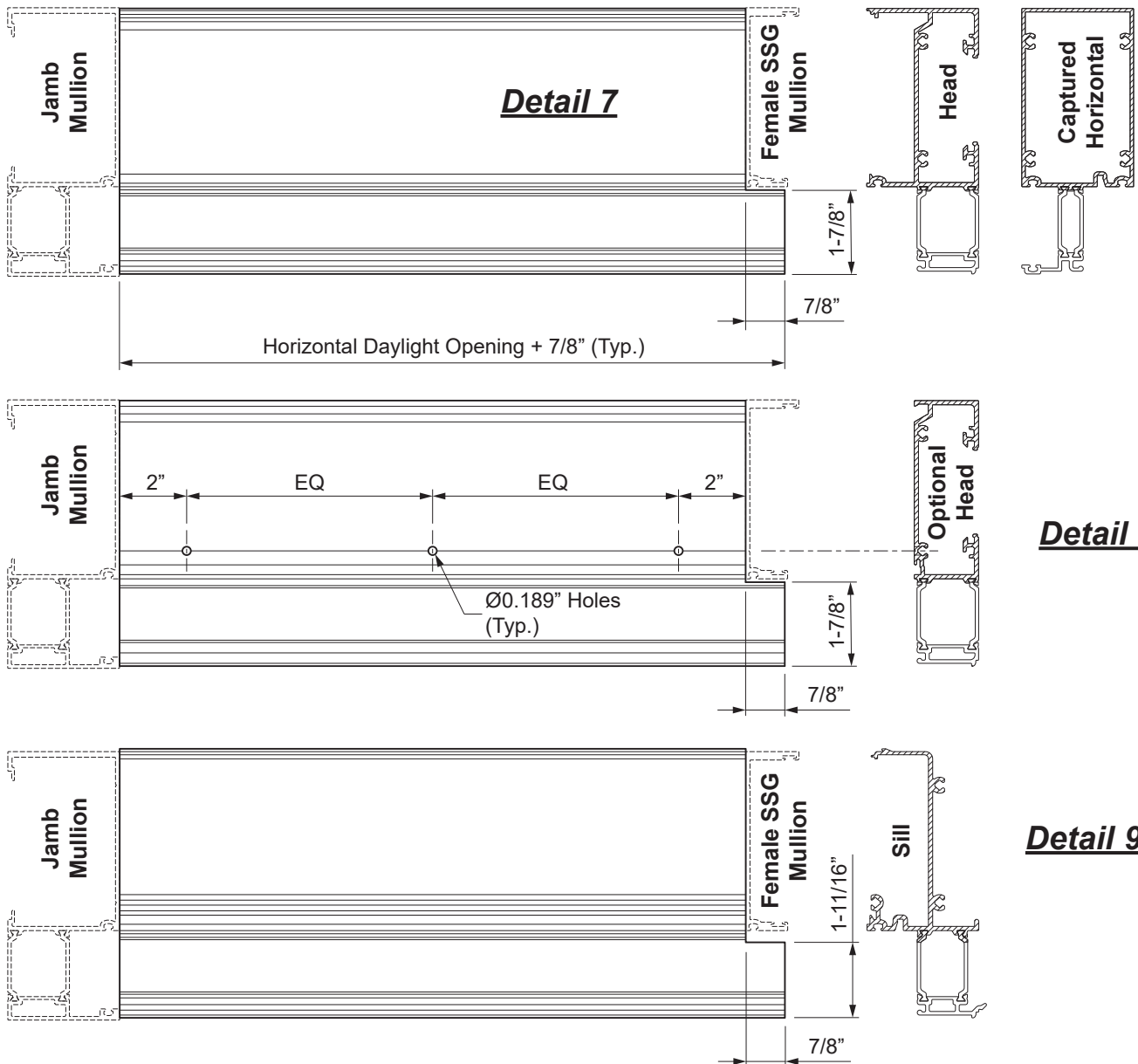

FRAME FABRICATION

**STEP 3 (Continued)
FABRICATE HORIZONTALS**

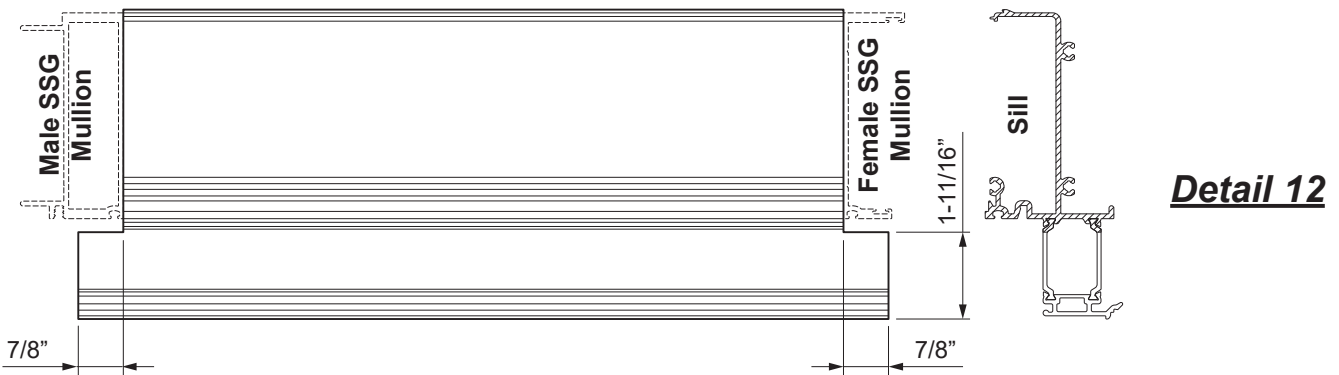
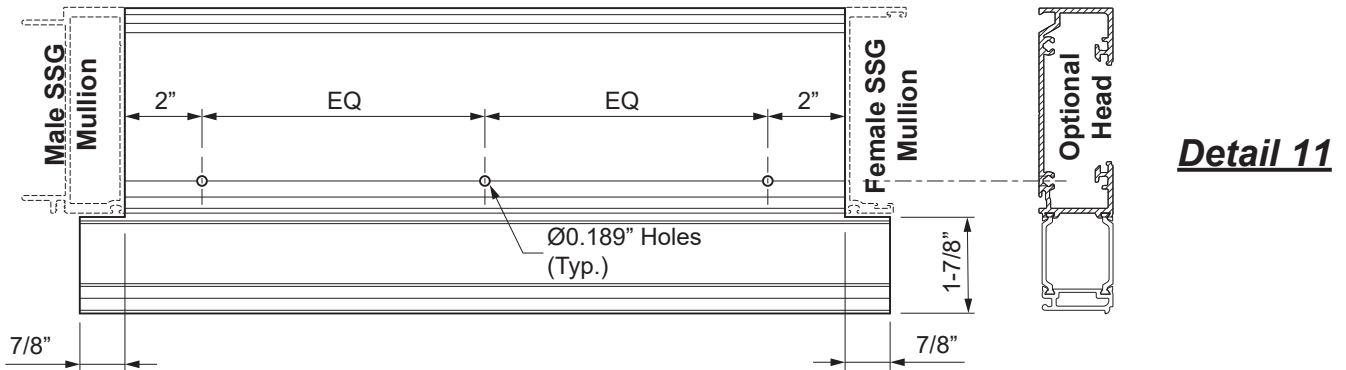
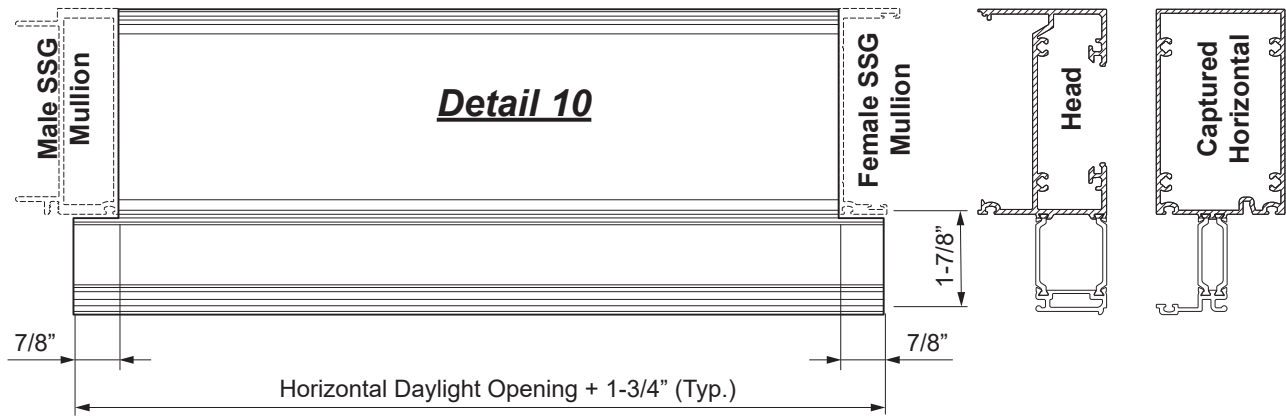

FRAME FABRICATION

STEP 3 (Continued)
FABRICATE HORIZONTALS

- SSG Horizontals for 90° corner are miter cut to Daylight Opening as shown in **Detail 13**.
- All other corner horizontal members are miter cut and or notched to dimensions as shown in **Details 14 thru 18**.
- Optional head member (BE9-6318) will require $\varnothing 0.189$ " tap holes as shown in **Details 14 & 17**.

Note: Sill members at SSG Mullions are notched differently from head members and captured horizontals to allow water to drain.

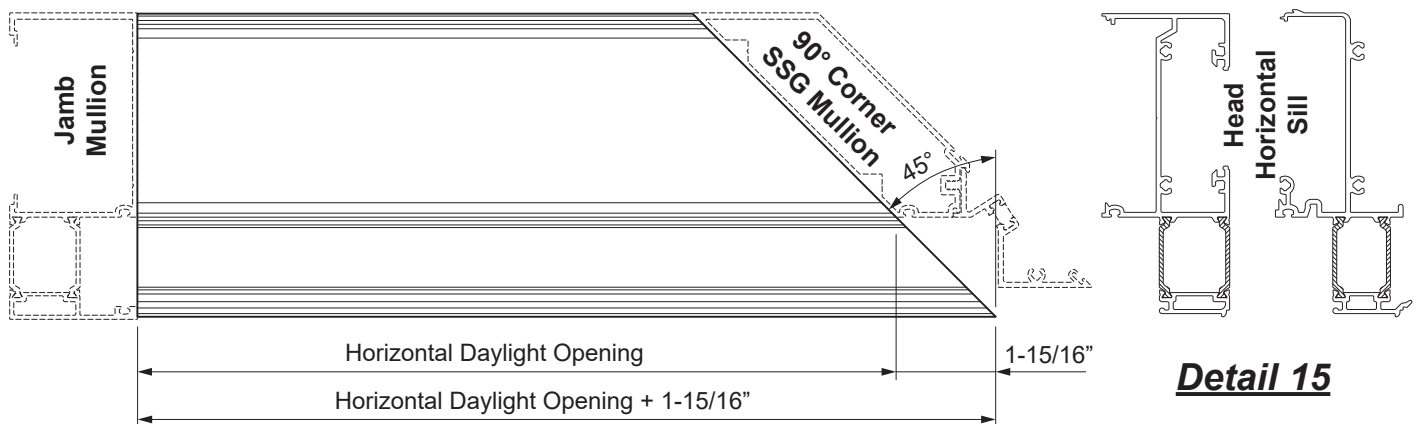
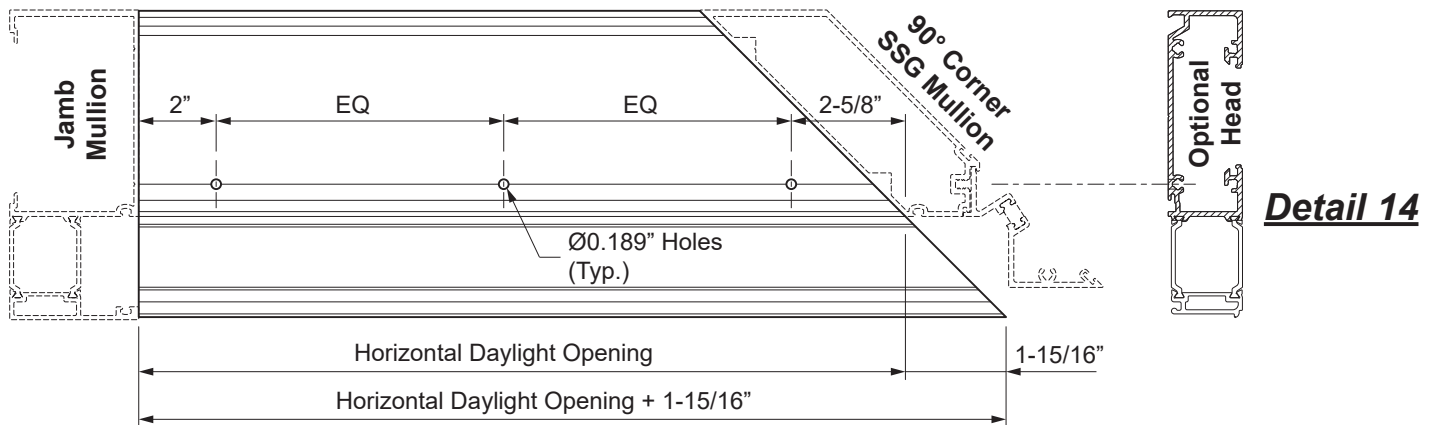
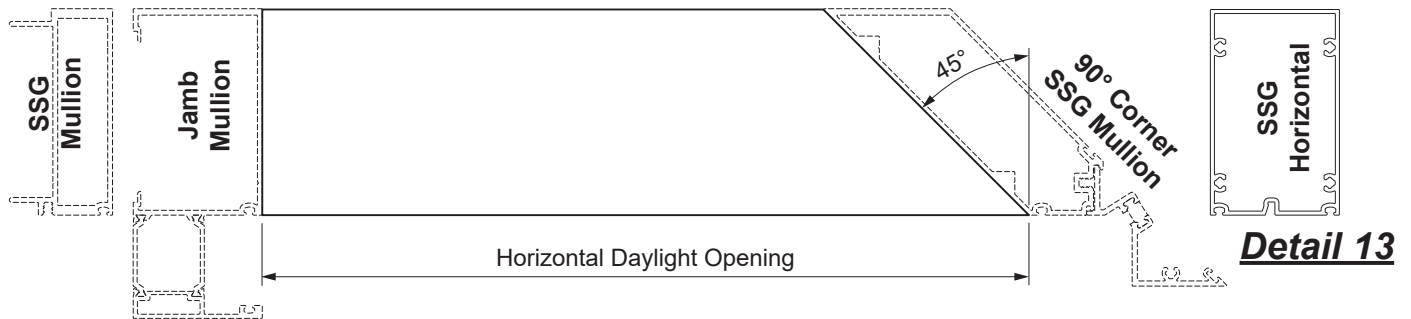

FRAME FABRICATION

**STEP 3 (Continued)
FABRICATE HORIZONTALS**

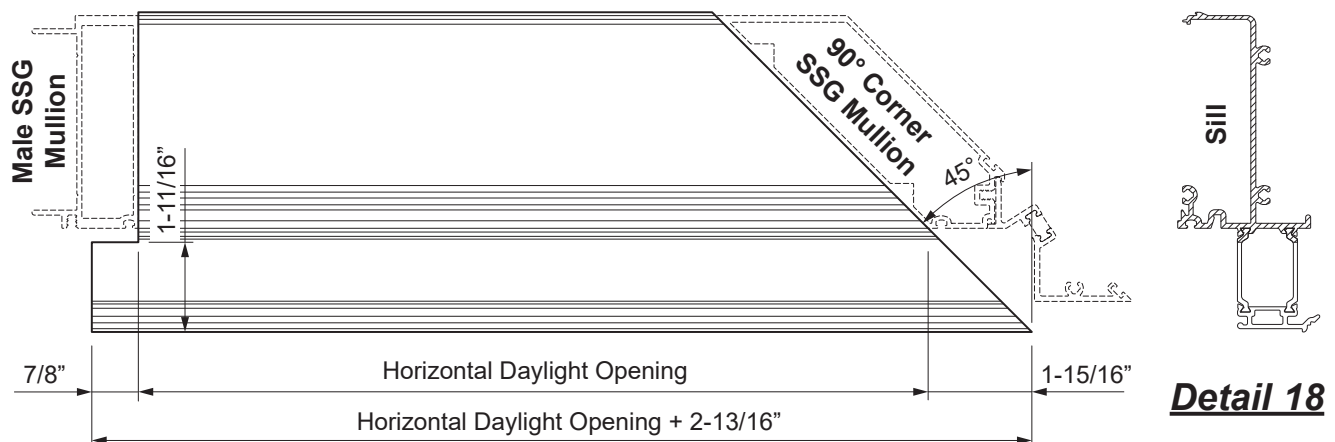
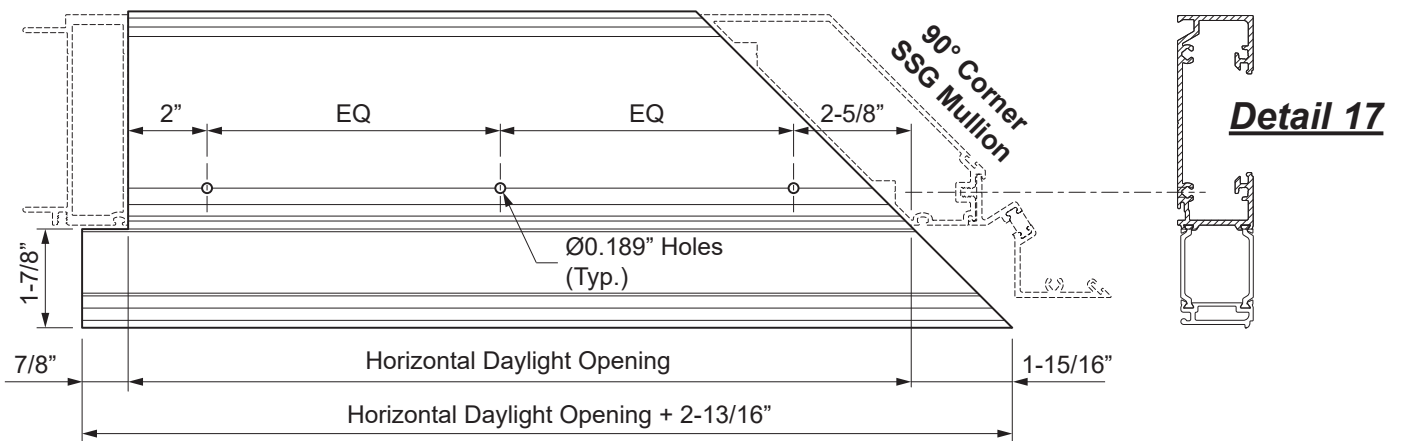
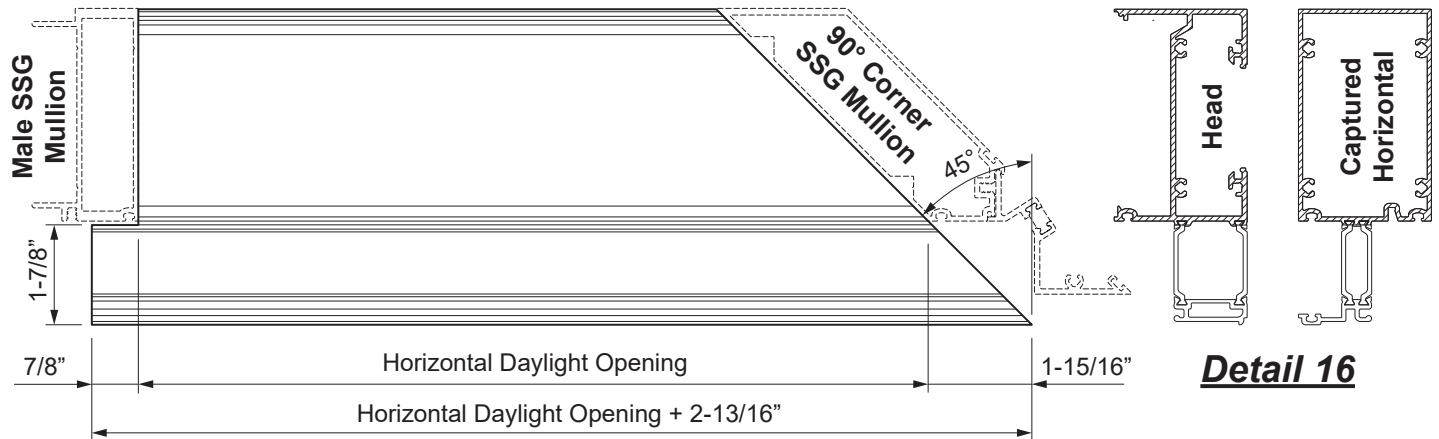

FRAME FABRICATION

STEP 3 (Continued)
FABRICATE HORIZONTALS

When the head is anchored to the substrate with the E1-2830 anchor, access holes will need to be drilled into the head member.

- Temporarily clamp the E1-2830 anchor onto the head where it will be in relation to the head member once anchored to the substrate.
- Drill 5/16" diameter holes into the head in line with the holes in the anchor. Unclamp the anchor. Then drill the access holes out to 1-1/2" diameter.

Notes: This is in addition to the 0.189" diameter tap holes for the glass stop. Refer to approved shop drawings for appropriate fastener and hole locations as determined by a qualified engineer.

See **Detail 19**.

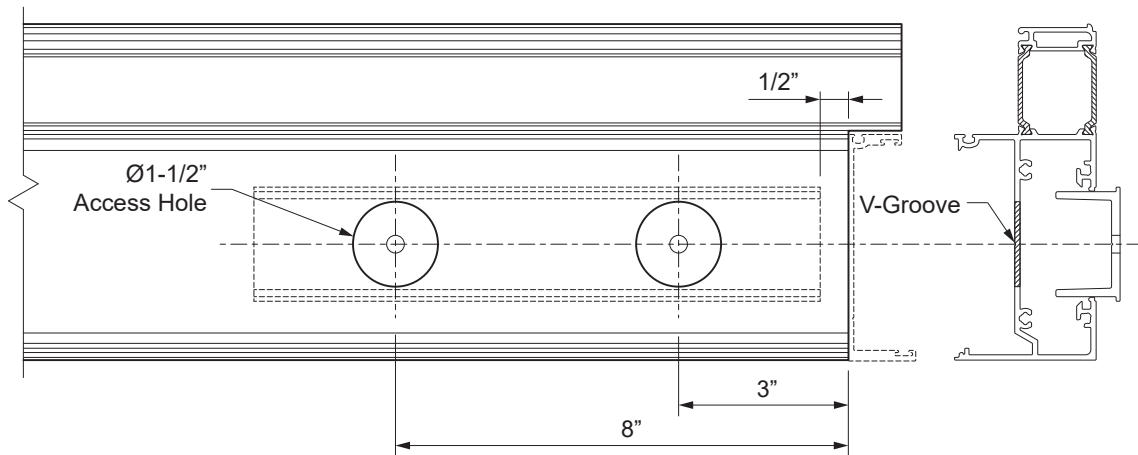

Detail 19

FRAME FABRICATION

**STEP 4
FABRICATE FILLERS & GLASS STOPS**

- Cut all vertical perimeter PVC back jamb fillers to the length of the jambs.
- Cut all horizontal flush fillers and interior covers to horizontal daylight opening minus(-) 1/32".

See **Detail 20**.

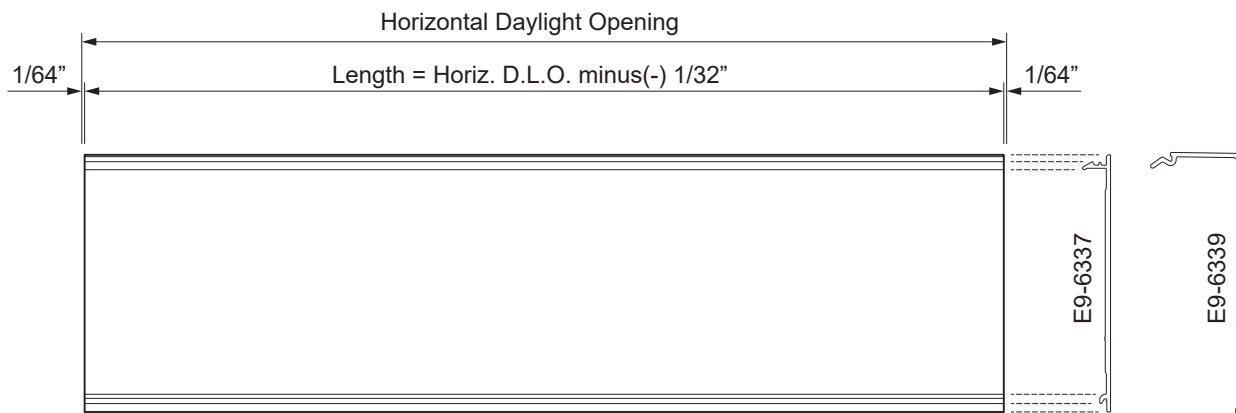

Detail 20

- Cut glass stops to horizontal daylight opening minus(-) 1/8".
- For the E9-7852 interior glass stops, drill two Ø0.236" clear holes along the v-groove in the glass stop as shown in **Detail 21**.
- Add a third hole at centerline for glass stops over 48" in length.

Note: Ø0.236" clear hole for glass stop is 2-9/16" from the end at 90° and 135° corner.

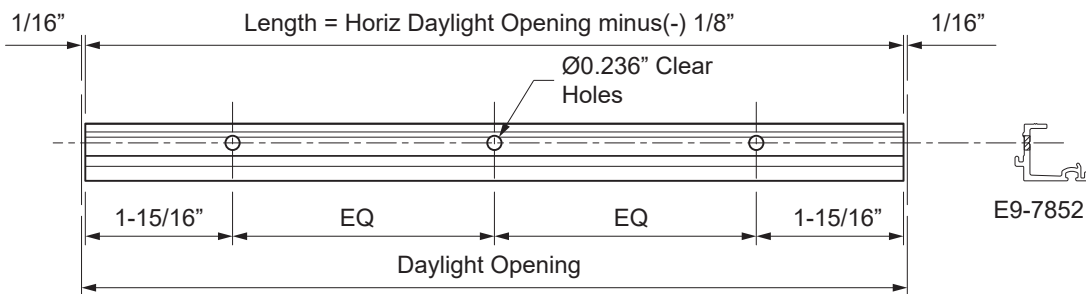

Detail 21

FRAME FABRICATION

STEP 4 (Continued)
 FABRICATE FILLERS & GLASS STOPS

-Cut E9-6338 exterior glass stops to the dimensions shown below in **Detail 22**.

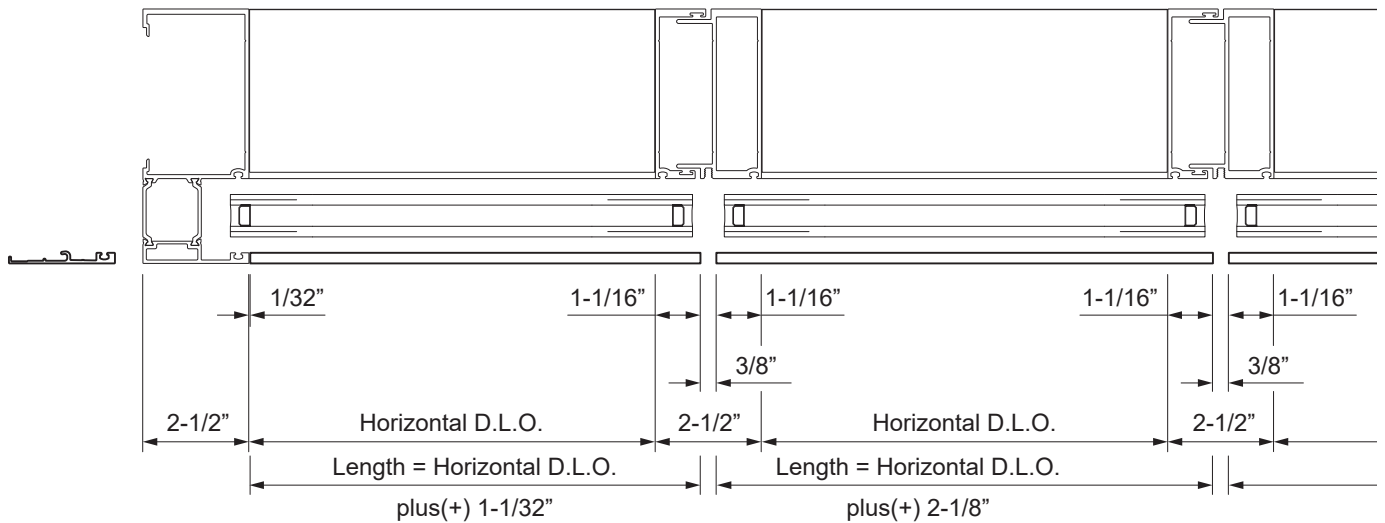

Detail 22

FRAME FABRICATION

**STEP 4 (Continued)
FABRICATE FILLERS & GLASS STOPS**

- At 90° corners, flat fillers are miter cut to D.L.O. minus 3/16".
- Face covers at 90° corners are miter cut to the dimensions shown in **Detail 23**.

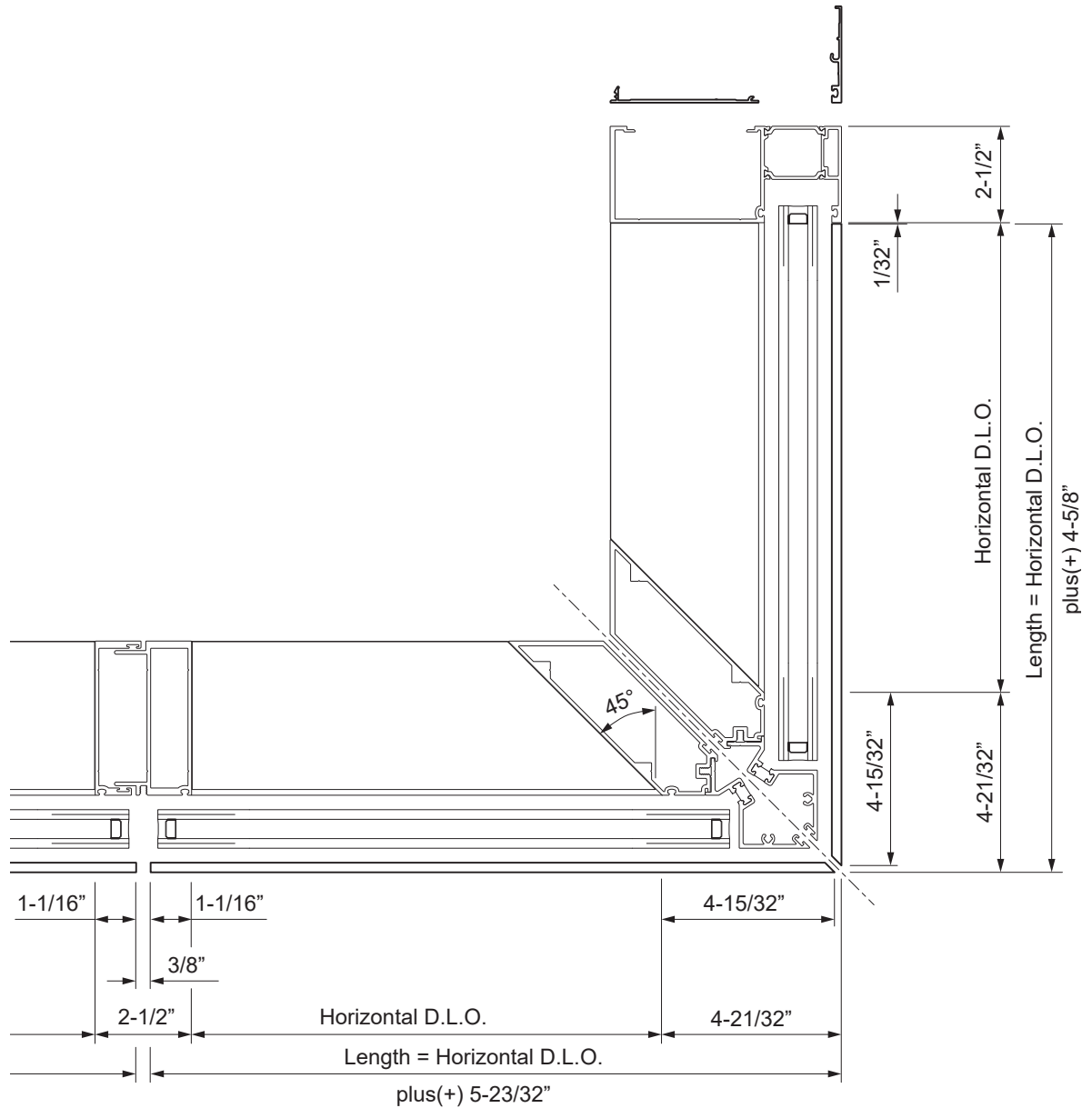

Detail 23

FRAME FABRICATION

STEP 5
FABRICATE SILL FLASHING & FLASHING FACE COVER

- Cut the sill flashing to the frame width plus(+) 5/16” at each jamb.
- Cut the E9-6342 flashing face cover to the same dimension as the interior of the flashing.
- Cut the flashing face cover to the same dimension as the interior of the sill flashing.

Note: For additional possibilities such as slab edge cover application, it is recommended to provide additional space between the edge of the sill flashing and the jamb substrate.

- For frame openings longer than 24’-0”, allow for a 3/8” splice joint between sill flashing members every twelve to fifteen feet at the center of a daylight opening.
 - Mark the front face of the sill flashing at the center of each vertical location and the midpoint of the daylight opening between the verticals.
 - Drill a 5/16” diameter weep hole in the face of the sill flashing at each location marked.
 - Drill a Ø0.213” clear hole in the back of the sill flashing at each location marked.
- See **Detail 24**.

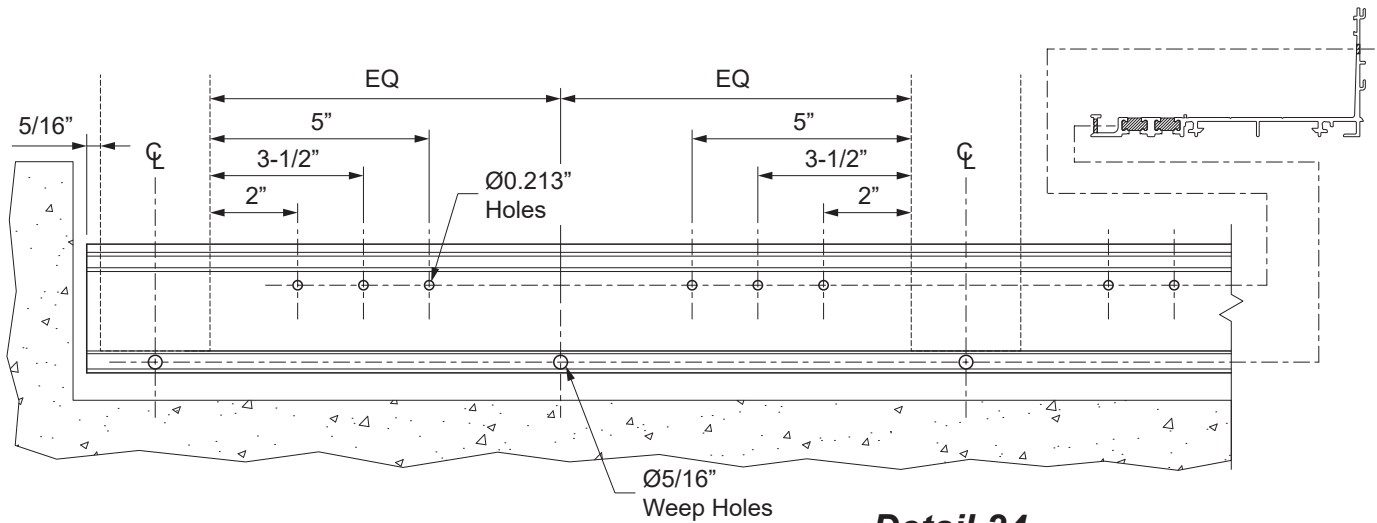

Detail 24

FRAME FABRICATION

**STEP 5A
FABRICATE SLAB EDGE PLATE ADAPTOR**

- Cut the aluminum plate adaptor E9-8222 to the same length as the sill flashing.
- Cut slab edge cover plates to length as indicated on the approved shop drawings.

See **Detail 25**.

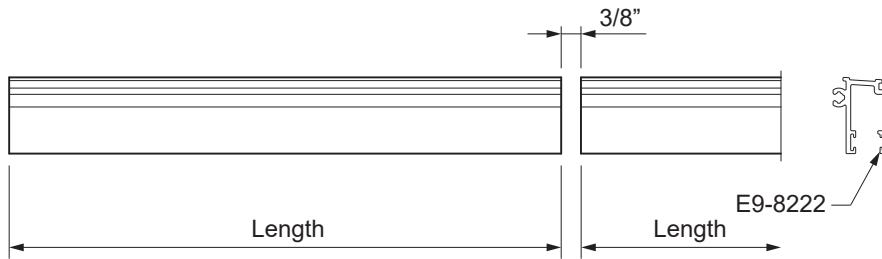

Detail 25

**STEP 6
FABRICATE CORNER ADAPTORS**

- Cut the corner adaptor components to the mullion length. Drill 0.213" diameter holes into the adaptor at the v-groove where the cover will be fastened to the mullion at 3" from each end and at 18" maximum on center.

See **Detail 26**.

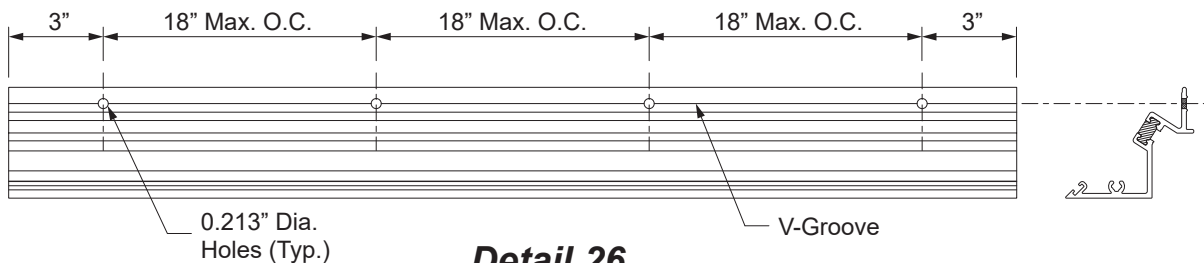

Detail 26
BE9-6357 Shown,
Others Similar

FRAME FABRICATION

STEP 7 FABRICATE HEAD RECEPTOR

- Cut the head receptor to the frame width plus(+) 5/16" at each jamb.
- Cut the E9-6343 head receptor snap cover to the same dimension as the interior of the head receptor.

Note: For additional possibilities such as slab edge cover application, it is recommended to provide additional space between the edge of the head receptor and the jamb substrate.

- For frame openings longer than 24'-0", allow for a 3/8" splice joint between sill flashing members every twelve to fifteen feet at the center of a D.L.O.
- Mark the front face of the head receptor at the center of each vertical location and the midpoint of the daylight opening between the verticals.
- Drill a 5/16" diameter weep holes in the head receptor at each location marked.
- Drill clear holes for anchor fasteners into the head receptor as indicated on the approved shop drawings and or P.E. calculations.

See **Detail 27**.

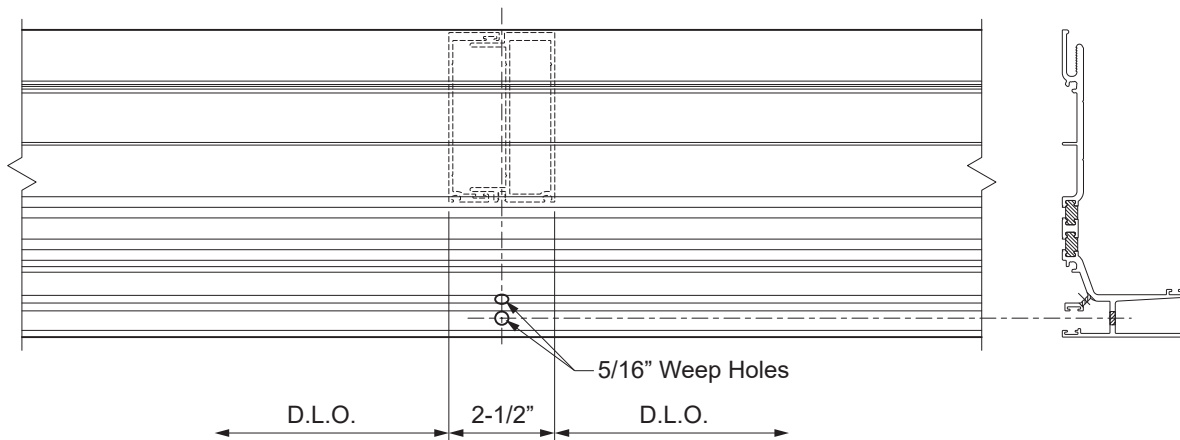

Detail 27

FRAME ASSEMBLY

**STEP 8
ASSEMBLE FRAME**

Note: It is recommended to lay out the unit pieces face down on a table or saw horses during assembly, fully supporting the mullions. If using saw horses, a brace tying the two together will be required.

- Clean all joint surfaces using cleaner approved by sealant manufacturer.
- Apply sealant to the end of the horizontals members to be attached to the first mullion or jamb, at the shaded areas of the head and intermediate horizontals and the entire end of the sill.

See **Detail 28**.

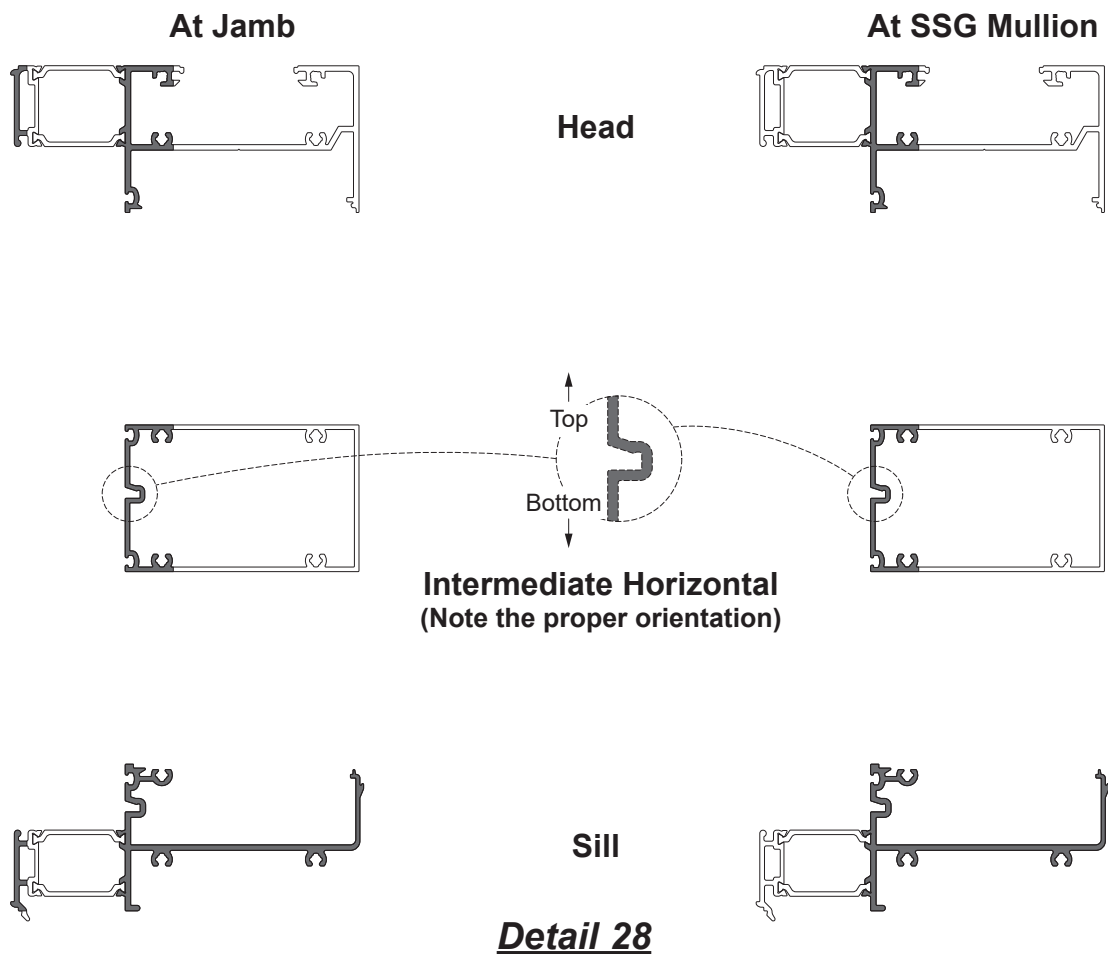

FRAME ASSEMBLY

STEP 8 (Continued)
ASSEMBLE FRAME

-Attach the horizontal members to the first mullion or jamb using PC-1220 screws, ensuring the proper orientation of the intermediate horizontal as previously shown on **Detail 28** and also ensuring that the bottom and back of the sill aligns with the bottom and back of the mullion as shown in **Detail 29A**.

Seal fastener heads.

-For Corner SSG mullions, use PC-1228 screws.

See **Detail 29**.

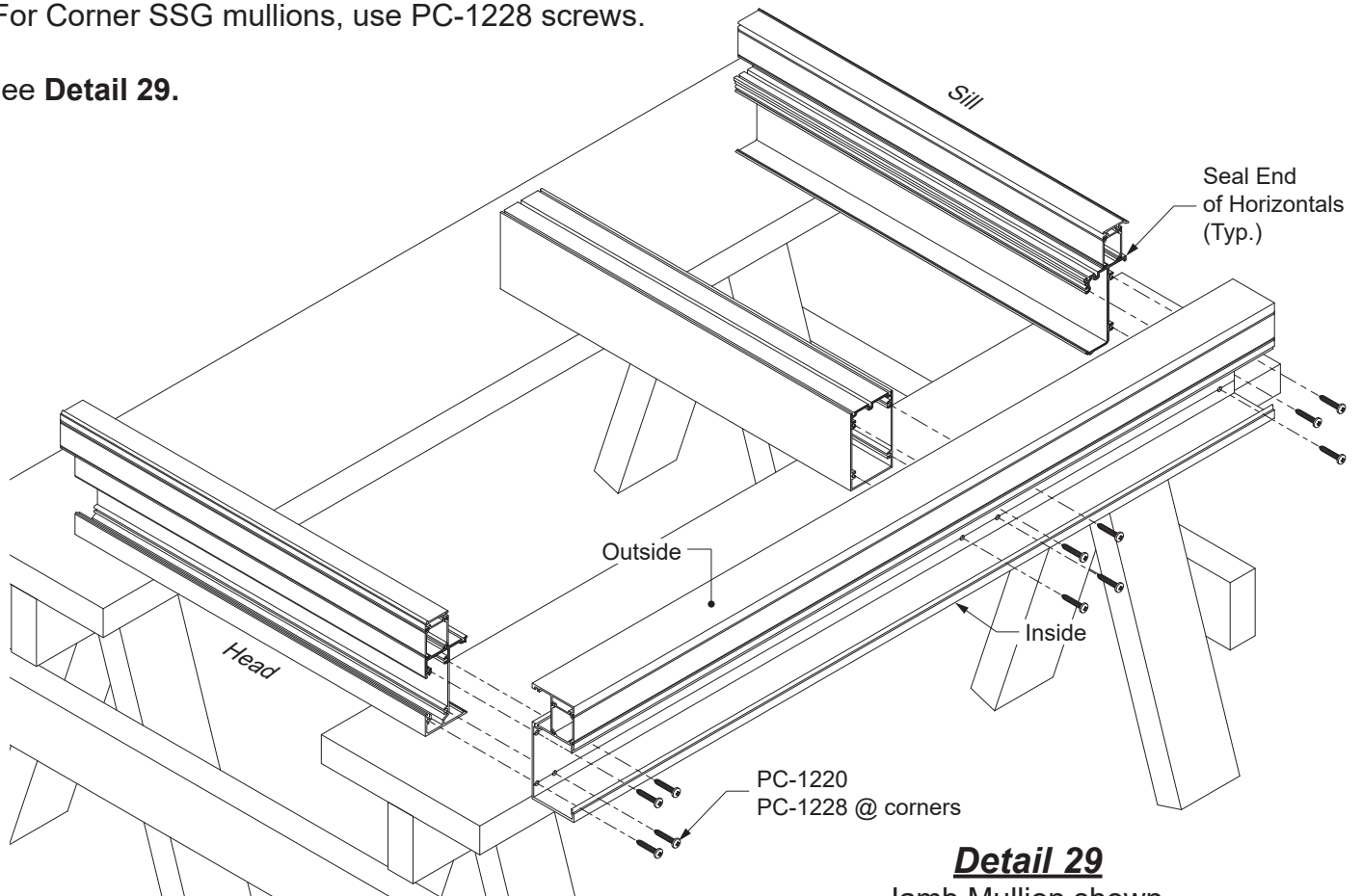

Detail 29
Jamb Mullion shown,
Female Mullion Similar

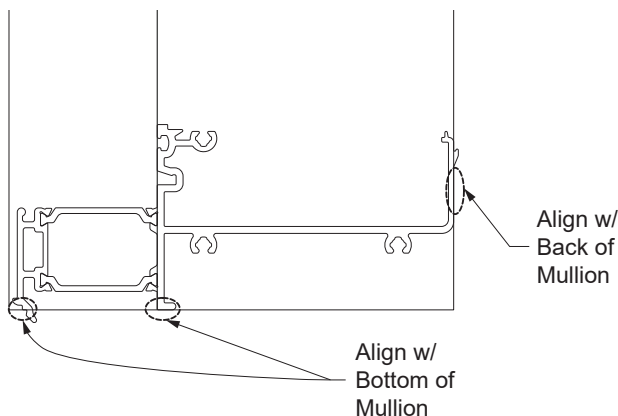

Detail 29A

FRAME ASSEMBLY

**STEP 8 (Continued)
ASSEMBLE FRAME**

- Apply sealant to the end of the head, horizontals, and sill that is to be attached to the second mullion or jamb as previously shown in **Detail 28**, also ensuring proper alignment at the bottom of the mullion.
- Attach the horizontal members to the mullion using PC-1220 screws (PC-1228 at corner mullions). See **Detail 30**. Seal fastener heads.

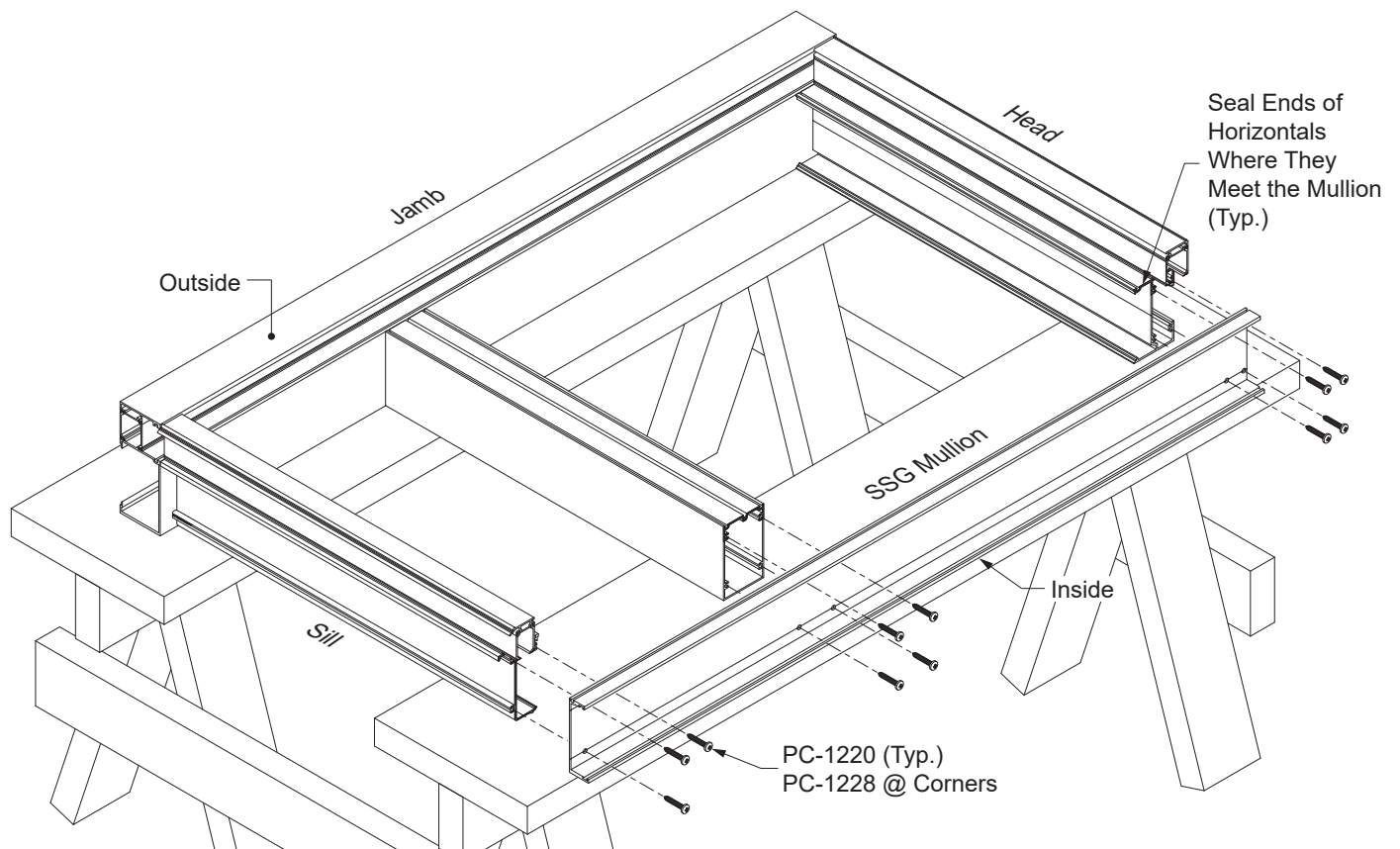

Detail 30

FRAME ASSEMBLY

STEP 8 (Continued)
ASSEMBLE FRAME (BE9-6318 OPTIONAL HEAD)

-If BE9-6318 optional head is used, apply continuous sealant across the reglet where the E9-7852 glass stop will hook into. See **Detail 31**.

-Also, apply sealant to the top corners of the mullions where the glass stops will be joined against the verticals.
 -Install the glass stop using PC-1210 screws.
 See **Detail 32**.

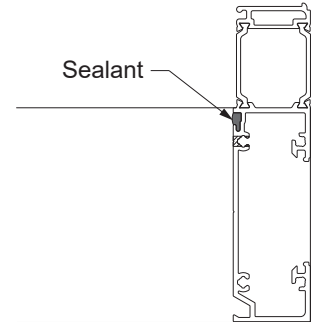

Detail 31

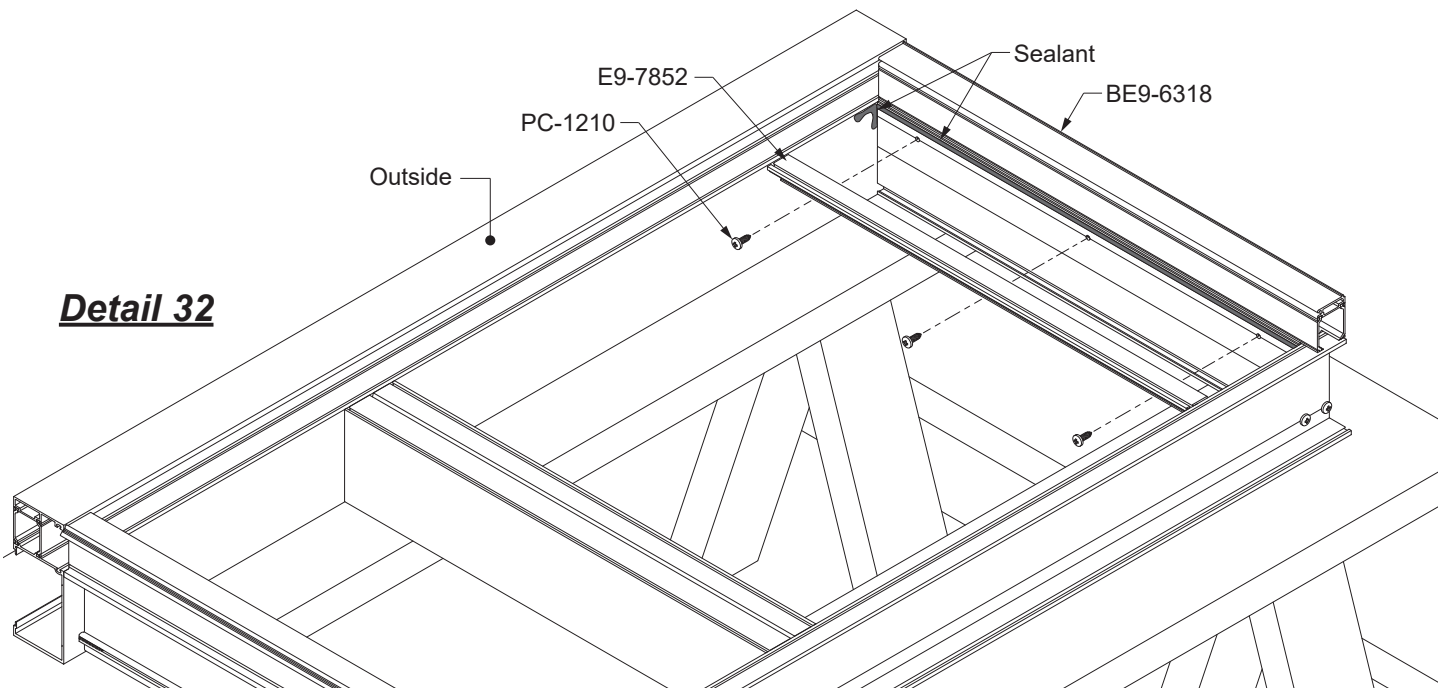

Detail 32

-Tool sealant at the interior of the glass stop where it meets the vertical.

See **Detail 33**.

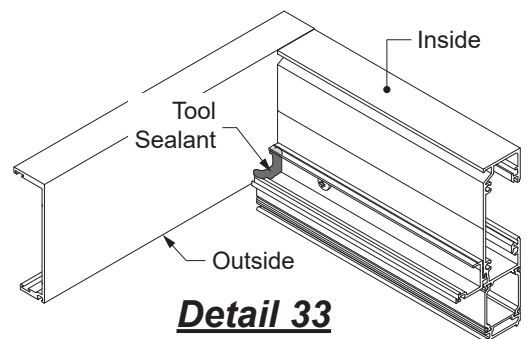

Detail 33
 As Shown from Underside

FRAME ASSEMBLY

**STEP 8 (Continued)
ASSEMBLE FRAME**

-Apply sealant and tool additional sealant to the head and sill as shown in **Details 34 & 35**.

-Fill the gap between the overlapping portion of the head member and captured horizontal and the front of the SSG mullion with sealant.

See **Detail 36**.

Note: Do not fill the gap at the front of the sill.

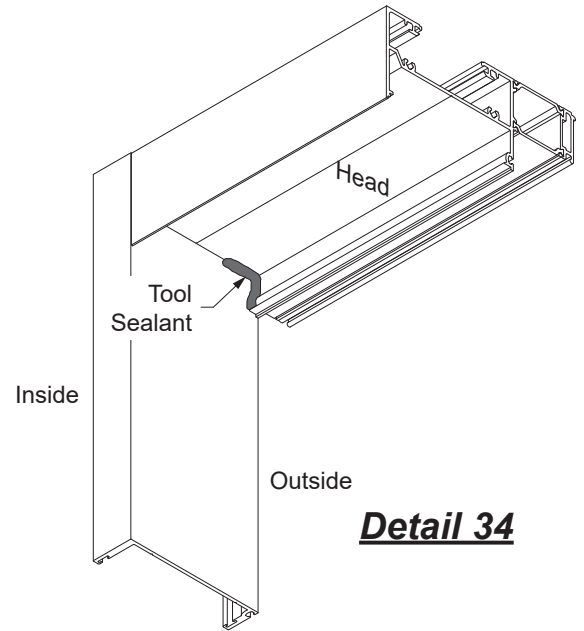

Detail 34

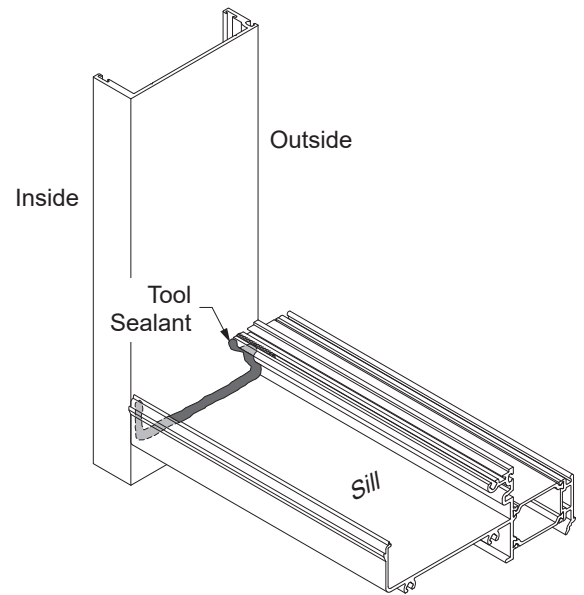

Detail 35

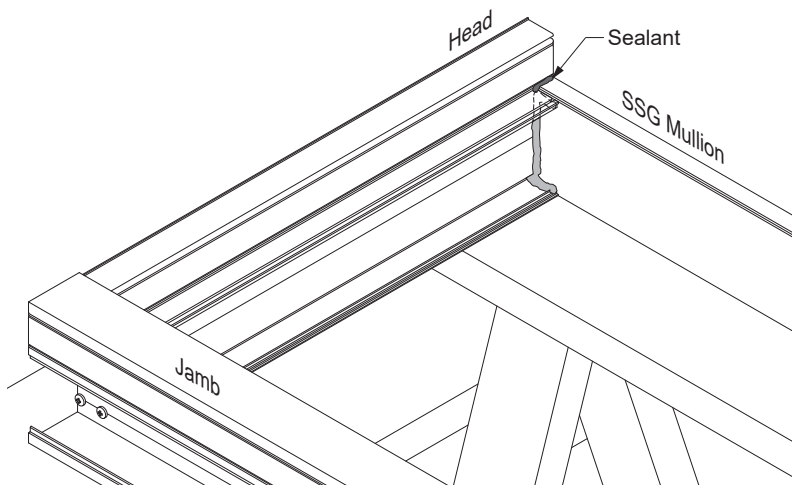

Detail 36

FRAME ASSEMBLY

**STEP 9 (Optional)
INSTALL STEEL REINFORCING**

- Install steel reinforcing into the mullions and jambs as required by the P.E. calculations and or approved shop drawings.
- Take care that the fasteners do not interfere with the horizontals nor would be visible when the unit is installed.

See **Detail 37**.

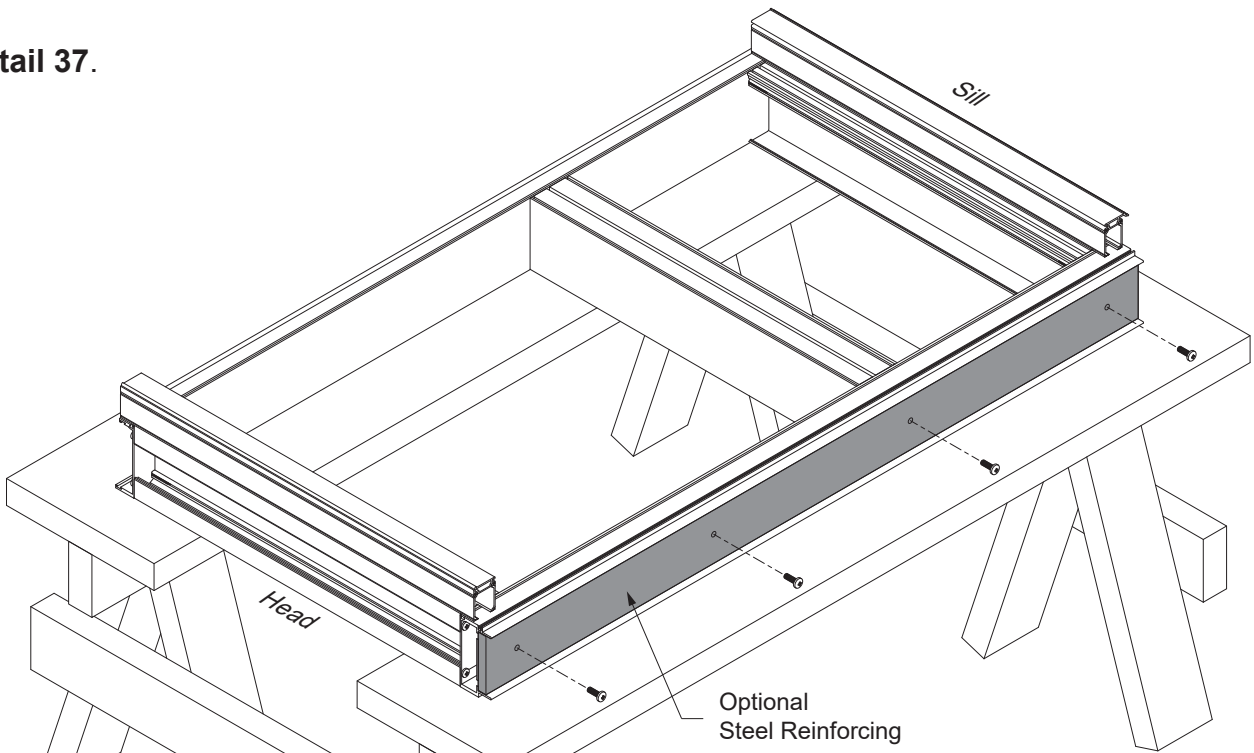

Detail 37

**STEP 10
INSTALL PERIMETER FILLERS**

For the open back Jamb, BE9-6311, snap on the jamb back filler E3-3667, cut to the length of the jamb mullion, into place as shown in **Detail 38**.

Note: Silicone can be added to keep the back jamb filler from sliding out.

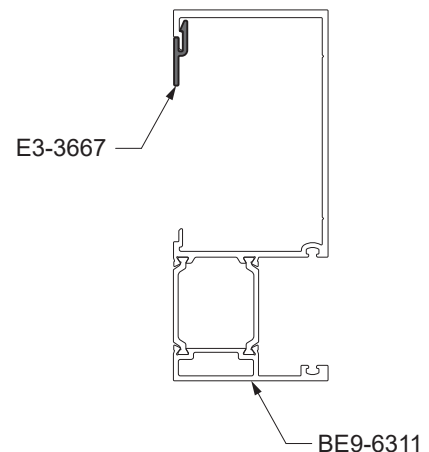

Detail 38

FRAME ASSEMBLY**STEP 11
INSTALL WEATHER SEAL**

Weather seal gaskets (E2-0065) are installed in the female mullion only.

-Cut the weather seal gasket to length of the vertical plus(+) 3", and install into the interior reglet of the female ssg mullion in the proper orientation as shown in **Detail 39**.

-Apply dabs of sealant to the bottom of the weather seal gasket to adhere it to the mullion so that it will not slide out during unit installation. Do not overseal. Too much silicone will deter mullion engagement.

-Trim the weather seal gasket after shrinkage.

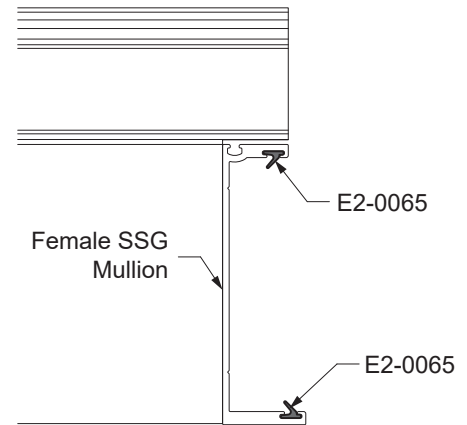

Detail 39

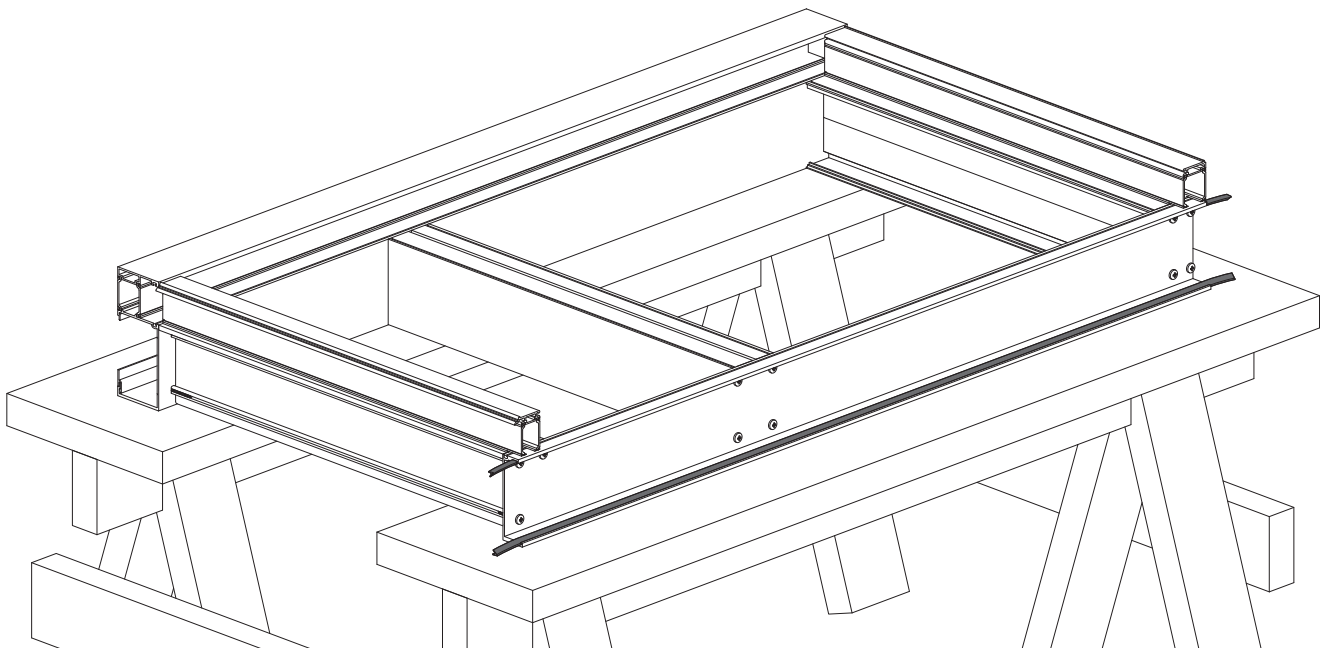

FRAME ASSEMBLY

STEP 12 (Optional, Not Necessary with Head Receptor Applications) INSTALL FOAM PLUGS AT HEAD

- Cut E2-0259 foam backer tape (maximum 1-1/4" long) to be installed at the head only. These will act as end caps for perimeter backer rods and sealant.
- Peel the adhesive tape from the foam and adhere it to the mullion as shown in **Detail 39**. The foam can be easily compressed around physical obstacles in the assembled verticals.
- In the case where steel reinforcing is present at the head, the foam plugs may be adhered to the steel.
- Fill the cavities at the front of any captured jambs with sealant.

Notes: For best adhesion, make sure the contact surfaces of the verticals and or steel members are clean and dry.
Also, take care to ensure the interior foam plug does not interfere with mullion engagement.

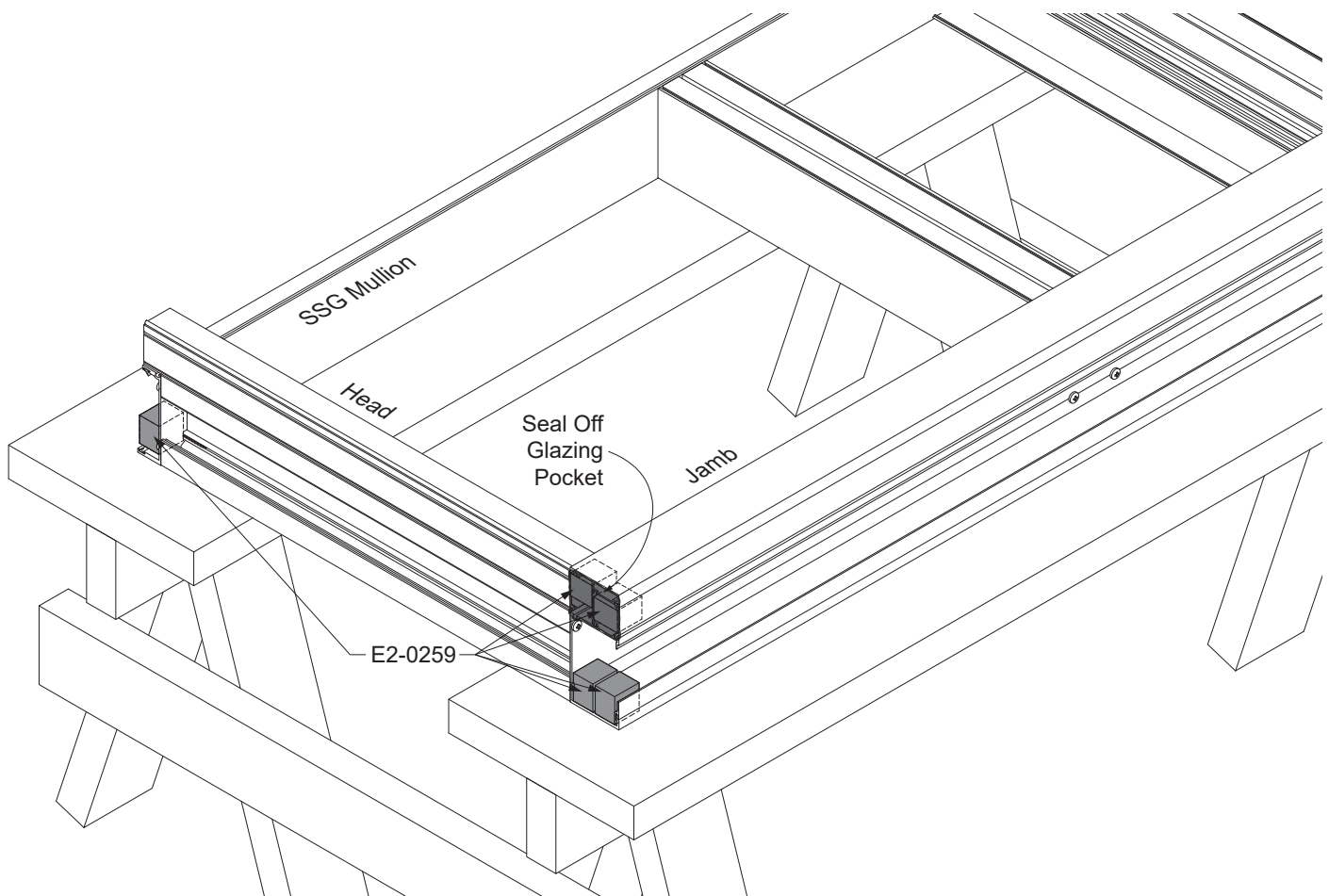

Detail 40

FRAME ASSEMBLY

**STEP 13
INSTALL INTERIOR GLAZING GASKETS**

- Using a small brush, clean out any dirt that may have accumulated in the gasket reglets.
- Vertical glazing gaskets must be installed first.

For All Vertical Gaskets

- Cut vertical gaskets to the Daylight Opening plus(+) 3/4" plus(+) an additional 1/4" for each foot of length.
- Insert the gasket into the reglets at each end first; then insert the gasket at the midpoint of the opening.
- Push the gasket into the reglet starting at the midpoint and work towards each end.

See **Detail 41**.

For dart gaskets at captured jambs:

- Cut vertical gaskets to the Daylight Opening plus(+) 3/4" plus(+) an additional 1/4" for each foot of length. Notch the ends of the vertical gasket as shown.

See **Detail 42**.

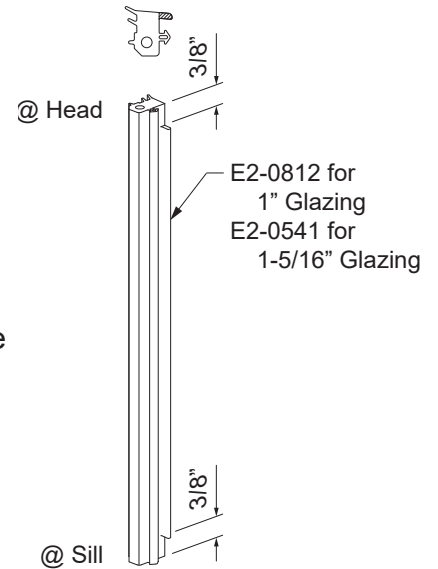

Detail 41

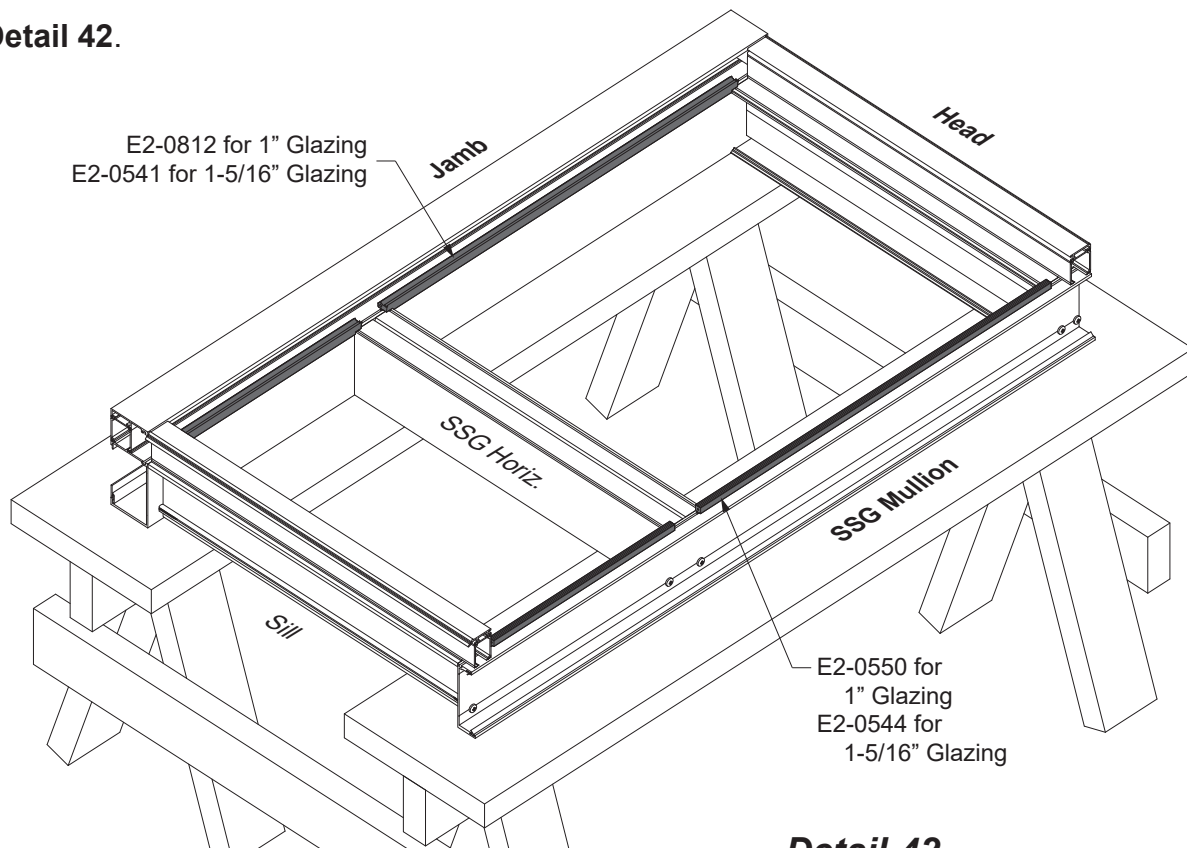

Detail 42

FRAME ASSEMBLY

STEP 13 (Continued)
INSTALL INTERIOR GLAZING GASKETS

Install horizontal glazing gaskets next:

- Cut horizontal glazing gaskets to Daylight Opening plus(+) 1/4" for each foot of length.
- Apply sealant to each end of the horizontal glazing gasket prior to inserting into the reglet.
- Insert the gasket into the reglet at each end first; then insert the gasket at the midpoint of the opening.
- Push the gasket into the reglet starting at each end and work towards the midpoint.
- Tool the excess sealant at the gasket corners to ensure a watertight seal.

See **Detail 43**.

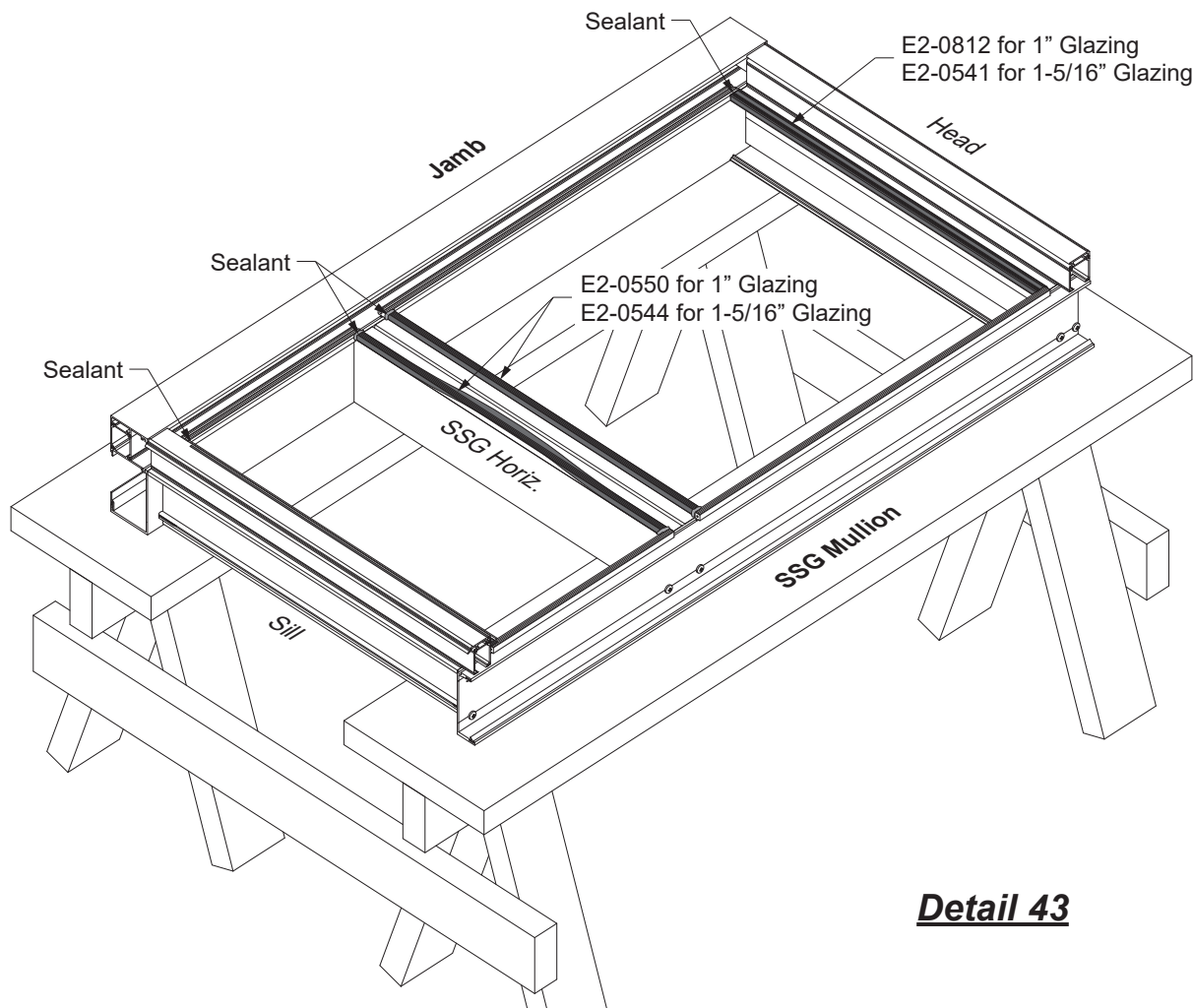

Detail 43

GLAZING







**STEP 14 (Continued)
INSTALL SIDE / HEAD BLOCKS**

-Refer to chart at right for setting blocks, setting block chairs, side blocks, and head blocks.

-For jamb mullions, add E2-0546 anti-walk blocks into the glazing pocket also as shown.

-Adhere E2-0068 setting blocks to the underside of the ends of the head member as shown.

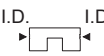
See **Detail 44**.

E1-2831		For 1" Glazing
E1-2833		For 1-5/16" Glazing
E2-0704PC		For 1" Glazing
E2-9611S		For 1-5/16" Glazing
E2-0546		For Jamb
* E2-0068		For Head & For Jamb on Unit w/ Corner Mullion
E2-0561		For 1" Glazing @ Horizontal SSG

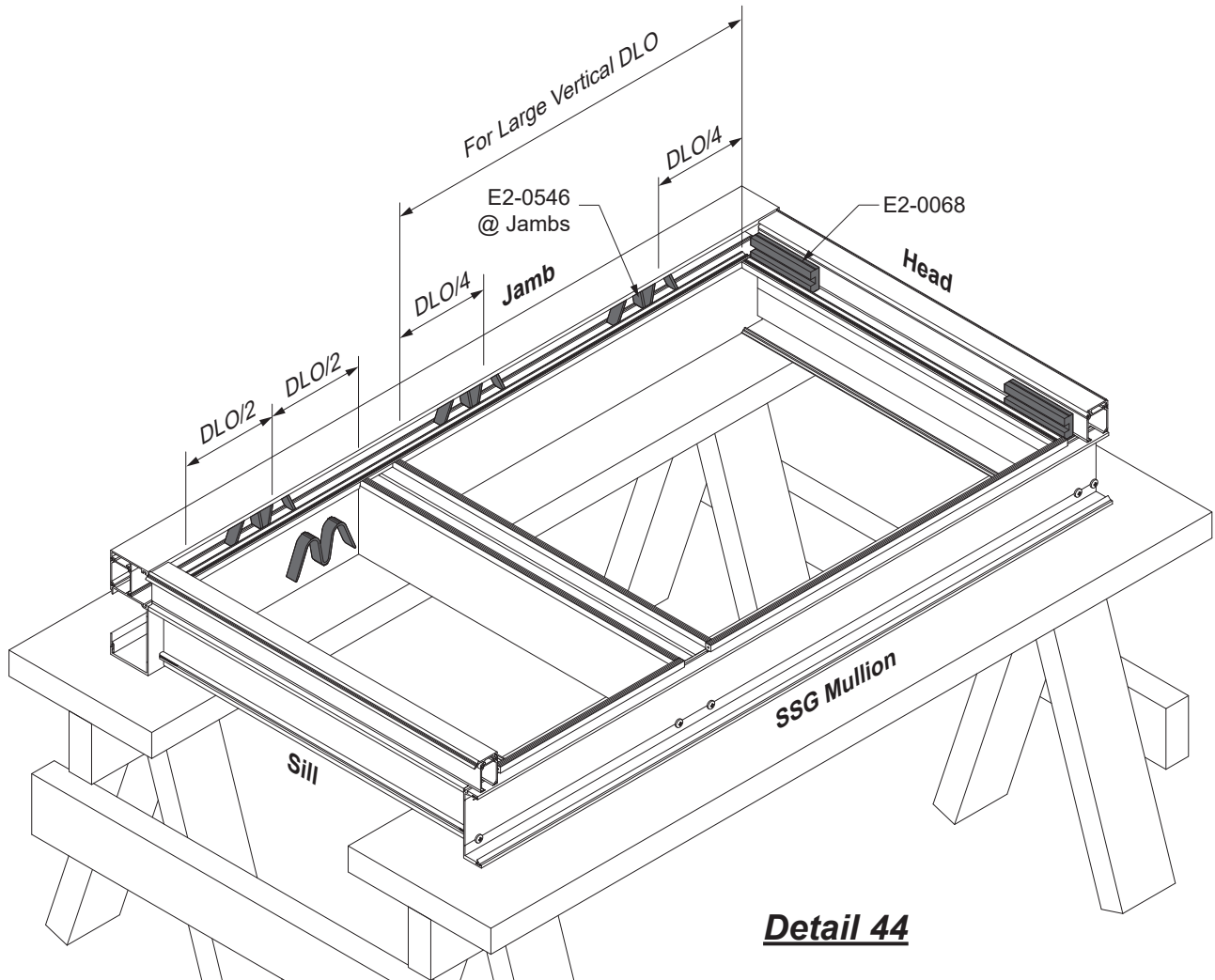

Detail 44

Packing/Shipping Notes for Jamb Units:

If packing units horizontally, ship with jamb side up.

* Two or more-sided SSG not required for head.

GLAZING

**STEP 15
INSTALL GLASS**

Determine the glass size based upon the vertical and horizontal conditions illustrated in **Detail 45**.

Ensure the unit is square before glazing

-Install the glass lites into the daylight openings. Position the glass lites ensuring the proper glass bites all around and tight against the setting blocks. Align the exterior edge of the glass with the edge of the female mullion half.

See **Details 45, 46, & 47**.

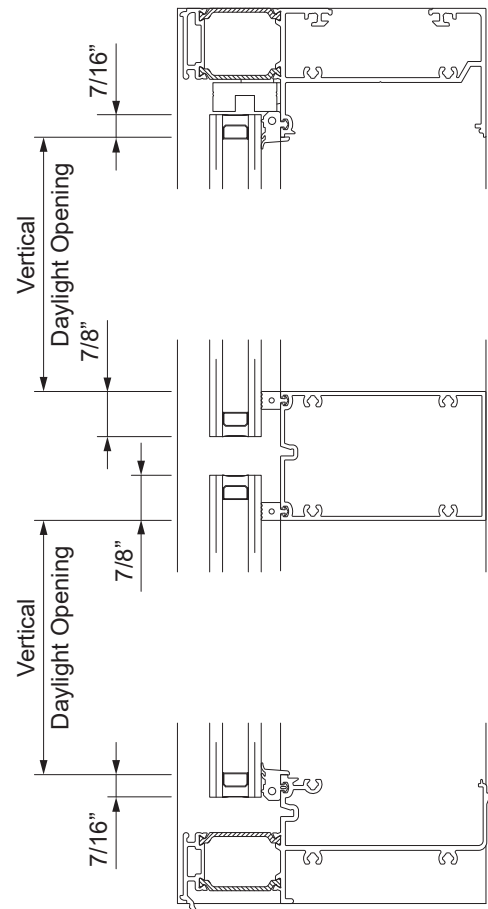

Detail 45

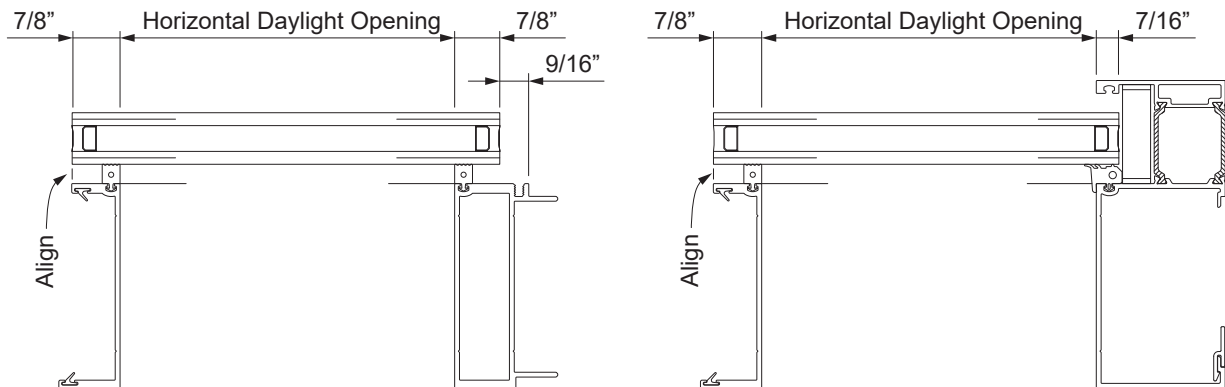

GLAZING

**STEP 15 (Continued)
INSTALL GLASS**

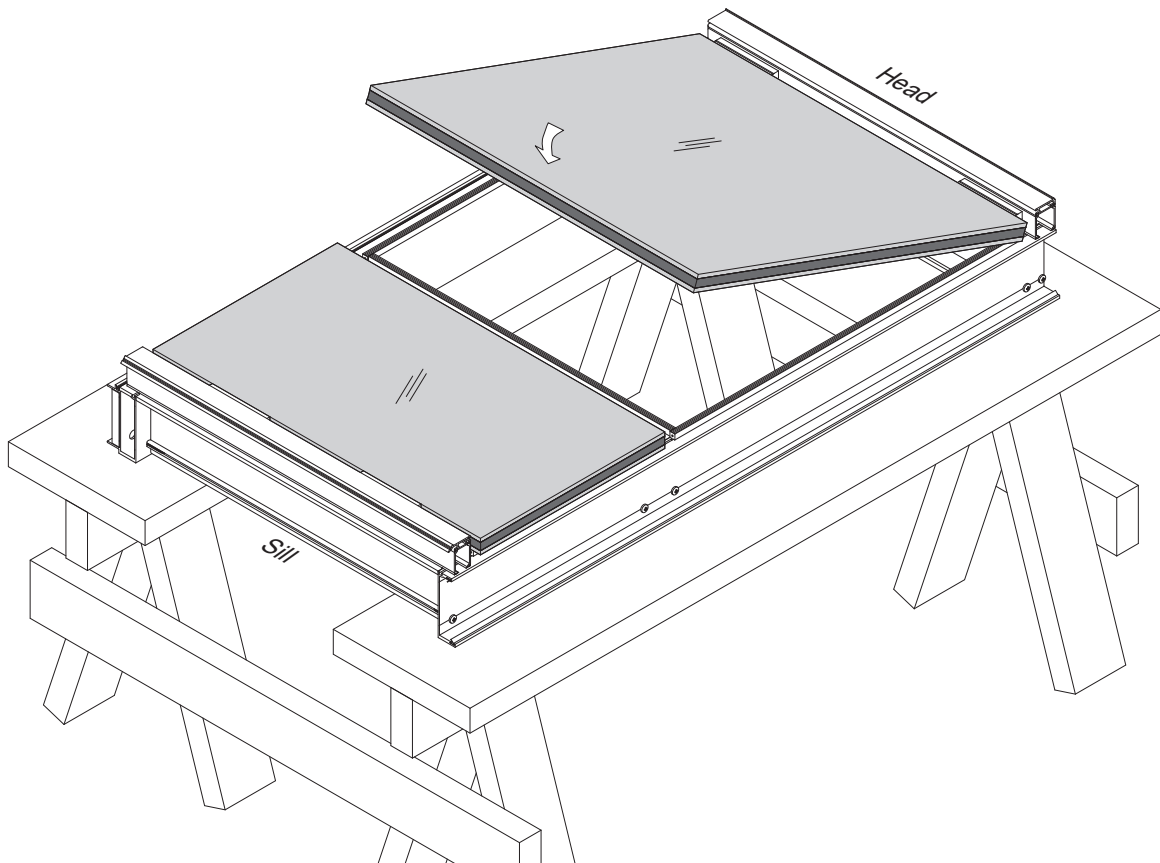

Detail 46
Intermediate Unit

GLAZING

STEP 15 (Continued)
INSTALL GLASS

Note: Intermediate horizontals cannot have setting block chairs at this point.

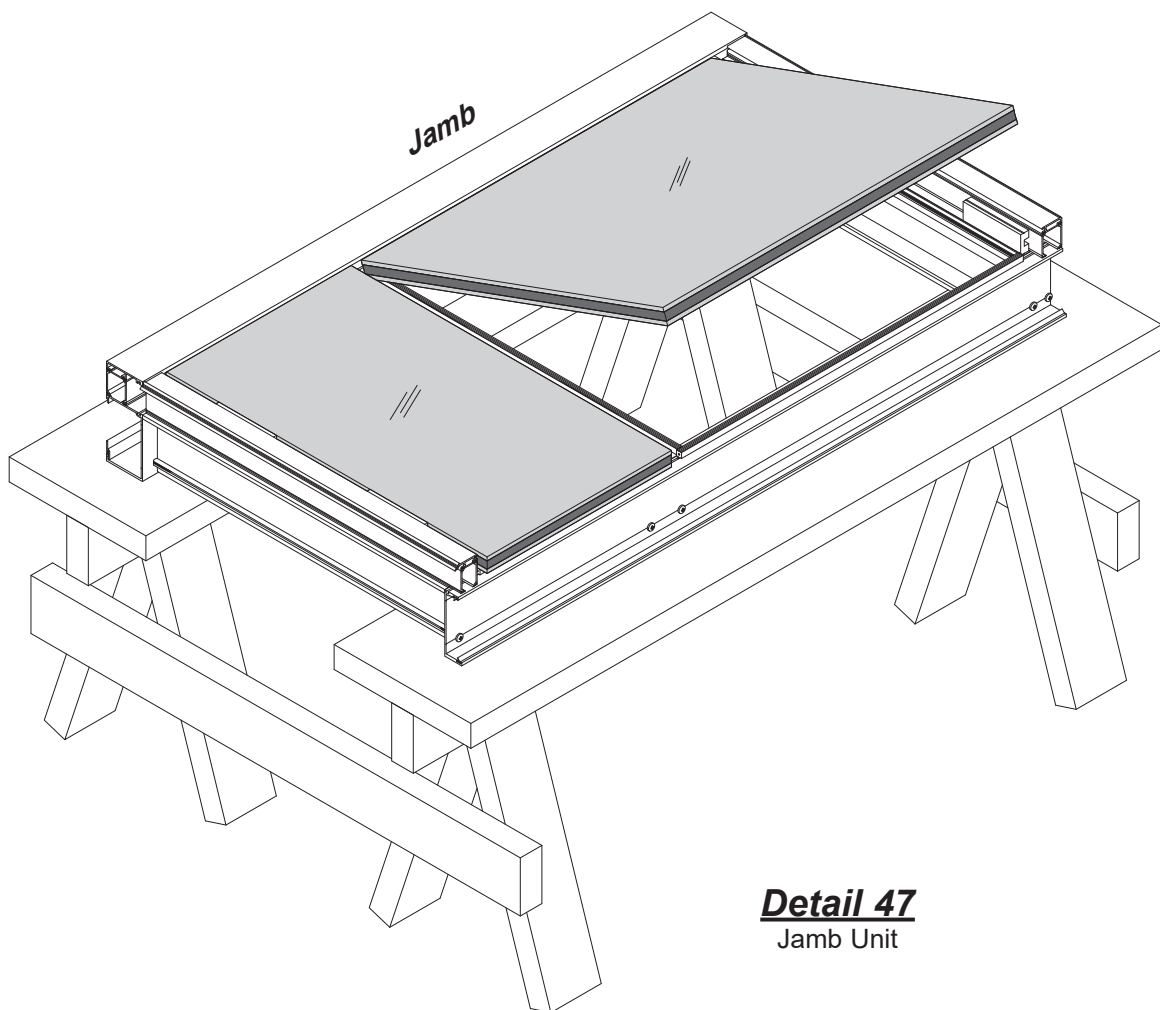

Detail 47
Jamb Unit

GLAZING

STEP 15 (Continued)
INSTALL SETTING BLOCKS AT SILL

-Apply setting blocks and setting block chairs into the glazing pockets to the sill shown in **Detail 48** at quarter points at every daylight opening. Do not apply setting block chairs to the intermediate horizontals at this time.

-Adhere the setting block chairs in place with sealant after insertion as shown in **Detail 48A**.

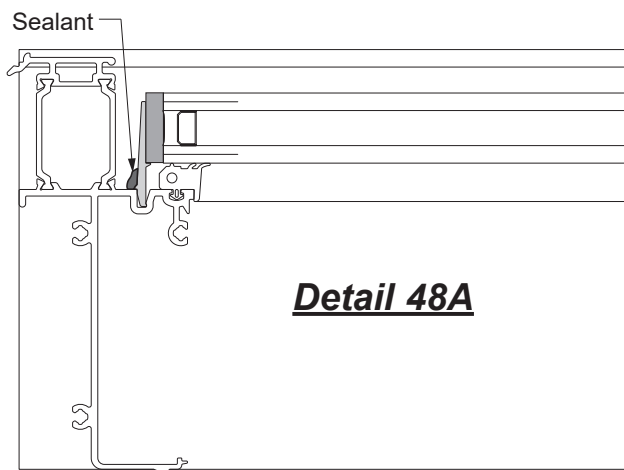
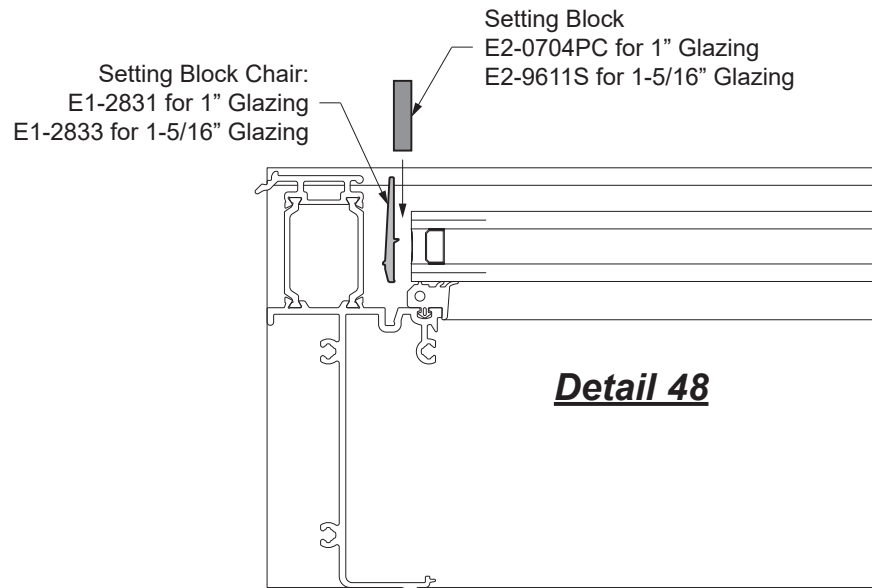

-After installation, ensure glass at the sill is positioned tightly against the sill setting blocks and or side blocks at the jamb or corner.

GLAZING

STEP 16 SEAL GLASS TO FRAME

-Apply structural silicone sealant to the gap between the glass and the frame, first at the intermediate SSG horizontals as shown in **Detail 49**.

-Apply the sealant to the remaining perimeter of the glass as shown in See **Detail 50**.

Note: Do not move the units until the sealant is fully cured.

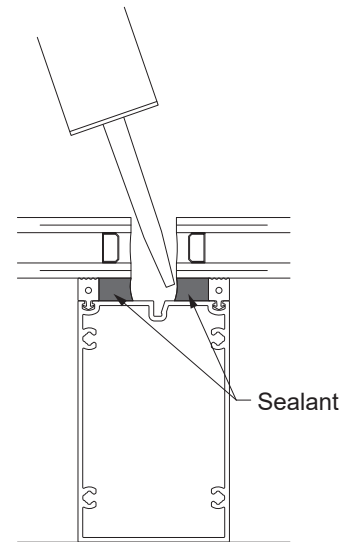

Detail 49

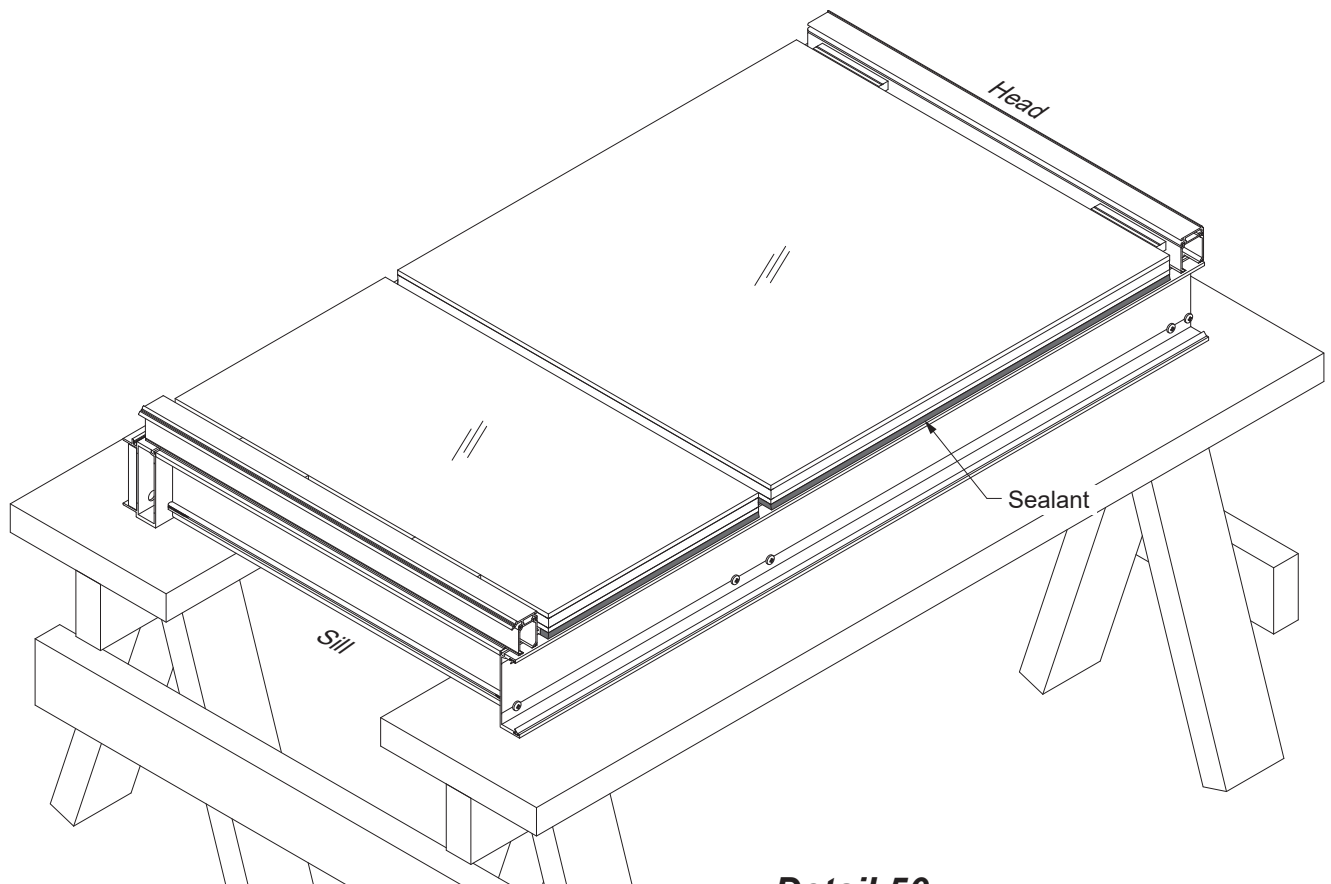

Detail 50

GLAZING

**STEP 17
INSTALL CORNER ADAPTORS**

Immediately after sealing the glass at corner mullion, attach the corner adaptors to the mullion with PM-1006-SS fasteners at the holes previously drilled during fabrication. Also insert E2-0051 bulb gaskets, cut to unit height plus 3", into the corner mullion assembly, leaving the ends to hang out at the top and bottom of the mullion. Apply dabs of sealant to the bottom of the bulb gasket reglets to adhere it to the corner mullion so that it will not slide out during unit installation.

See **Detail 51A**.

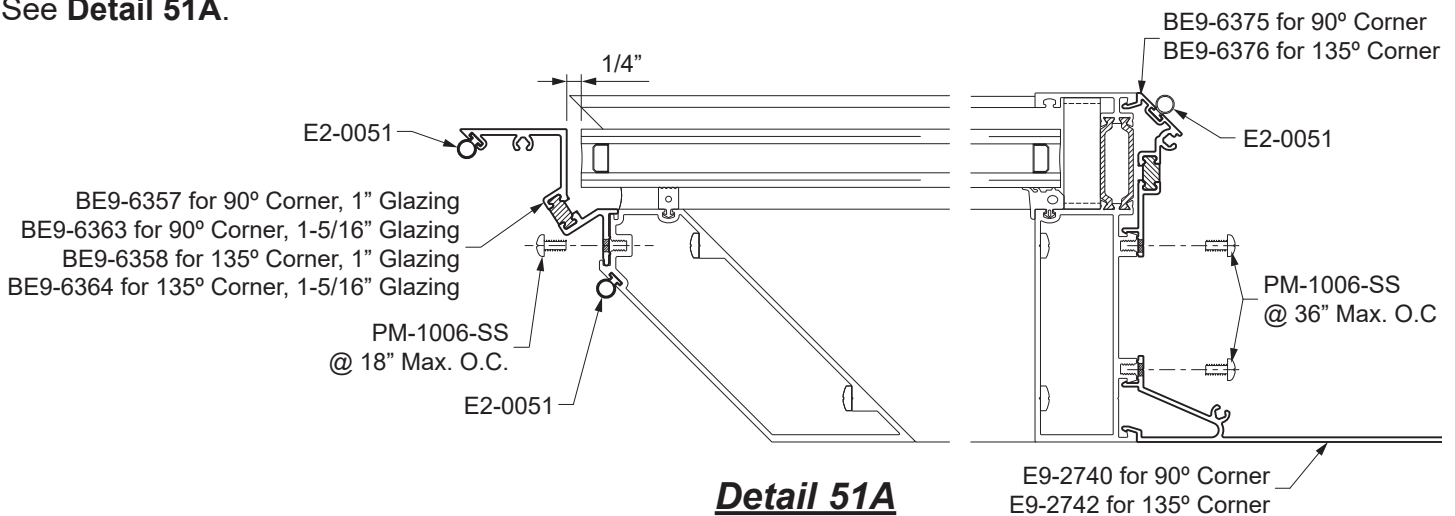

- Insert a backer rod between the glass and the corner adaptor.
- Apply and tool sealant to the joint between the glass and the adaptor.

See **Detail 51B**.

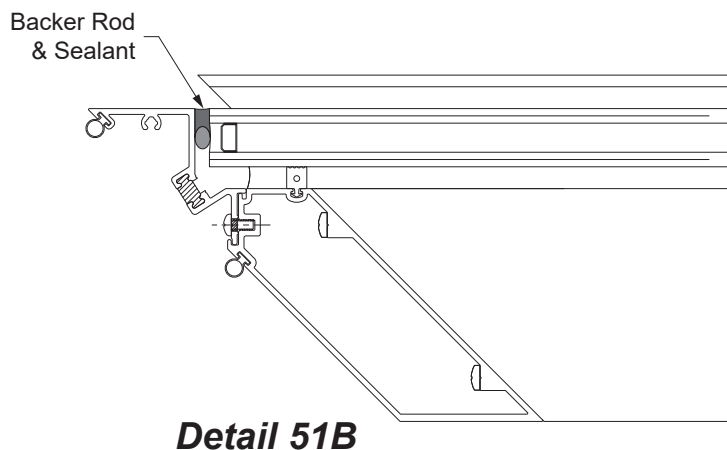

GLAZING

STEP 18 INSTALL OUTSIDE CORNER END CAPS

- Prior to attaching outside corner end caps at the head, trim off the excess bulb gasket.
- Apply sealant to the top of the mullion as shown in **Detail 52A**.

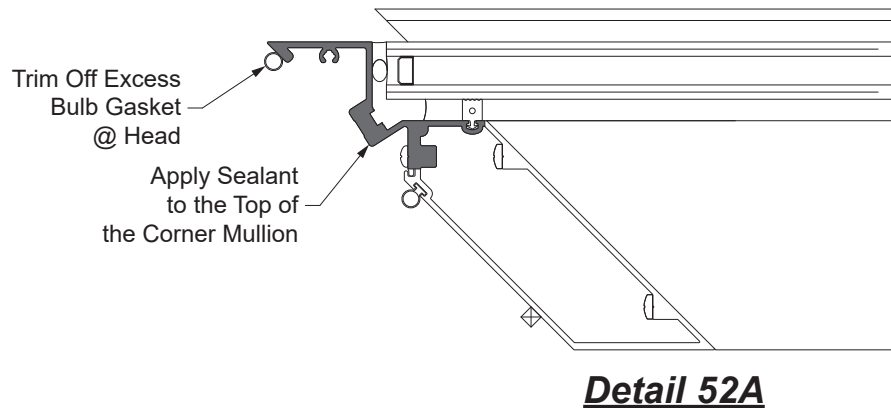

- Attach the corner end cap using (2) FC-1006-SS screws. See **Detail 52B**.

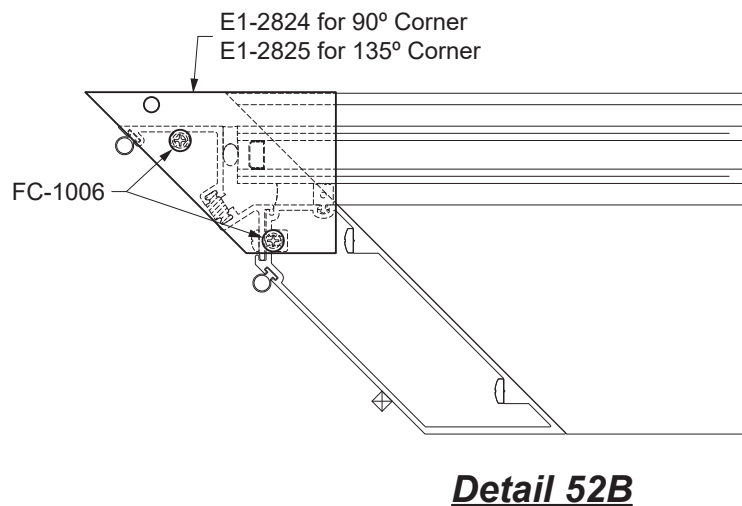

Note: Inside corner members utilize E2-0259 foam backer tape as previously shown on **Page 28**.

GLAZING

STEP 19

INSTALL SETTING BLOCKS FOR INTERMEDIATE HORIZONTALS

- At the intermediate horizontals, insert into place setting blocks chairs at quarter points of the horizontal daylight opening.
- Insert the setting blocks between the chairs and the glass as shown in **Detail 53A**.
- Insert a backer rod into the horizontal cavity, and fill the cavity with sealant as shown in **Detail 53B**.

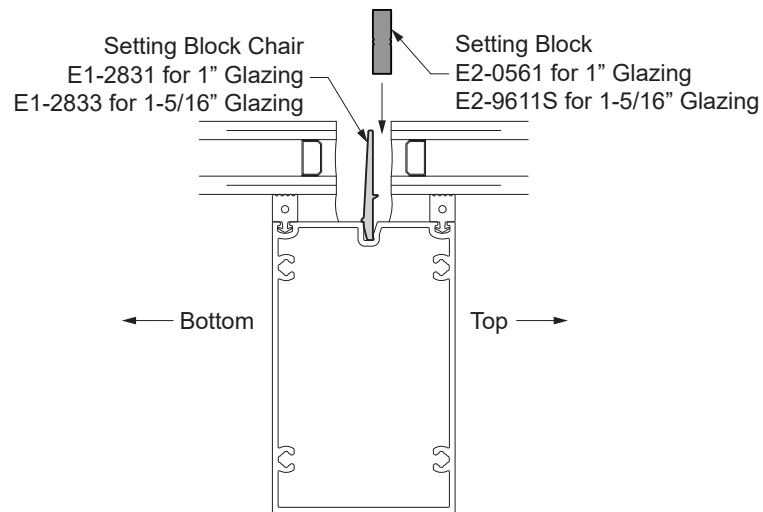

Detail 53A

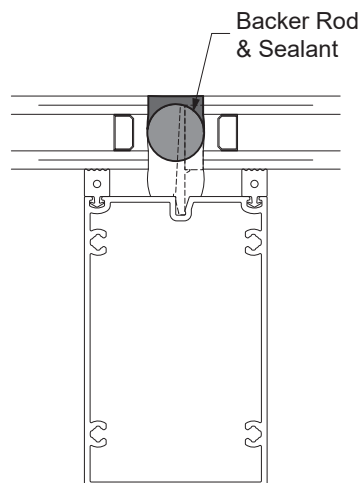

Detail 53B

GLAZING

STEP 20 INSTALL GLASS STOPS (FOR JAMB UNITS)

- Apply 6" of sealant to the ends of captured horizontals where the exterior glass stops will be set against. At the jamb mullion, seal the horizontals against the jamb mullion.
- Set the E9-6338 glass stops in place at the head and sill. Insert a 2" long section of wedge gasket to temporarily hold the glass in place.

See **Detail 54**.

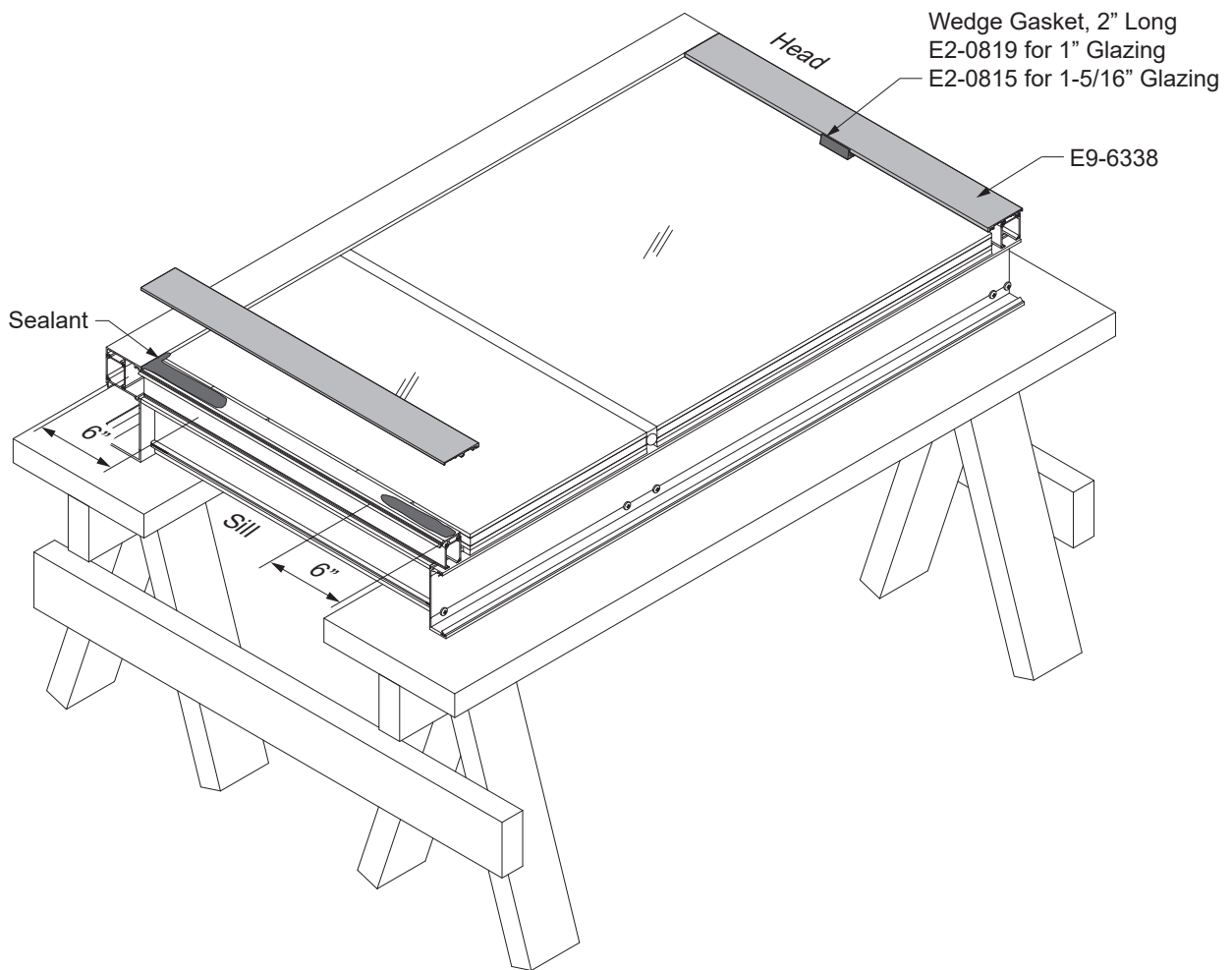

Detail 54

GLAZING

**STEP 20 (Continued)
INSTALL GLASS STOPS (FOR INTERMEDIATE UNITS)**

-Installation of the exterior glass stops is similar to that for the jamb unit except the glass stop is centered on the horizontal daylight opening and sealant is not applied against the jambs.

See **Detail 55**.

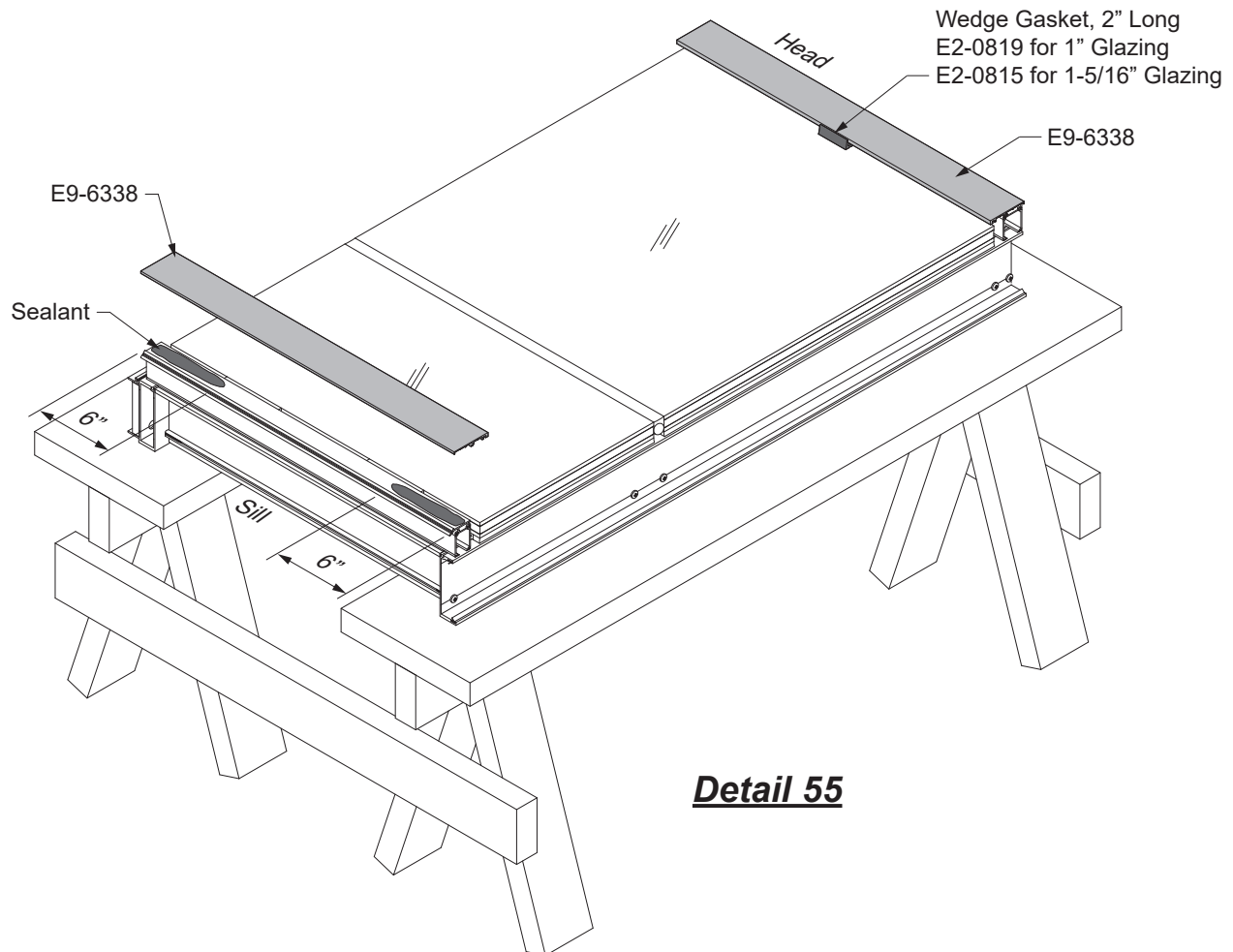

GLAZING

STEP 21 INSTALL SSG RAINSCREEN GASKET

-Cut the SSG rainscreen gasket to frame height. Apply sealant 6" long to the top and bottom of the male mullion where the gasket engages it as shown below in **Detail 56**. Insert the gasket into the mullion.

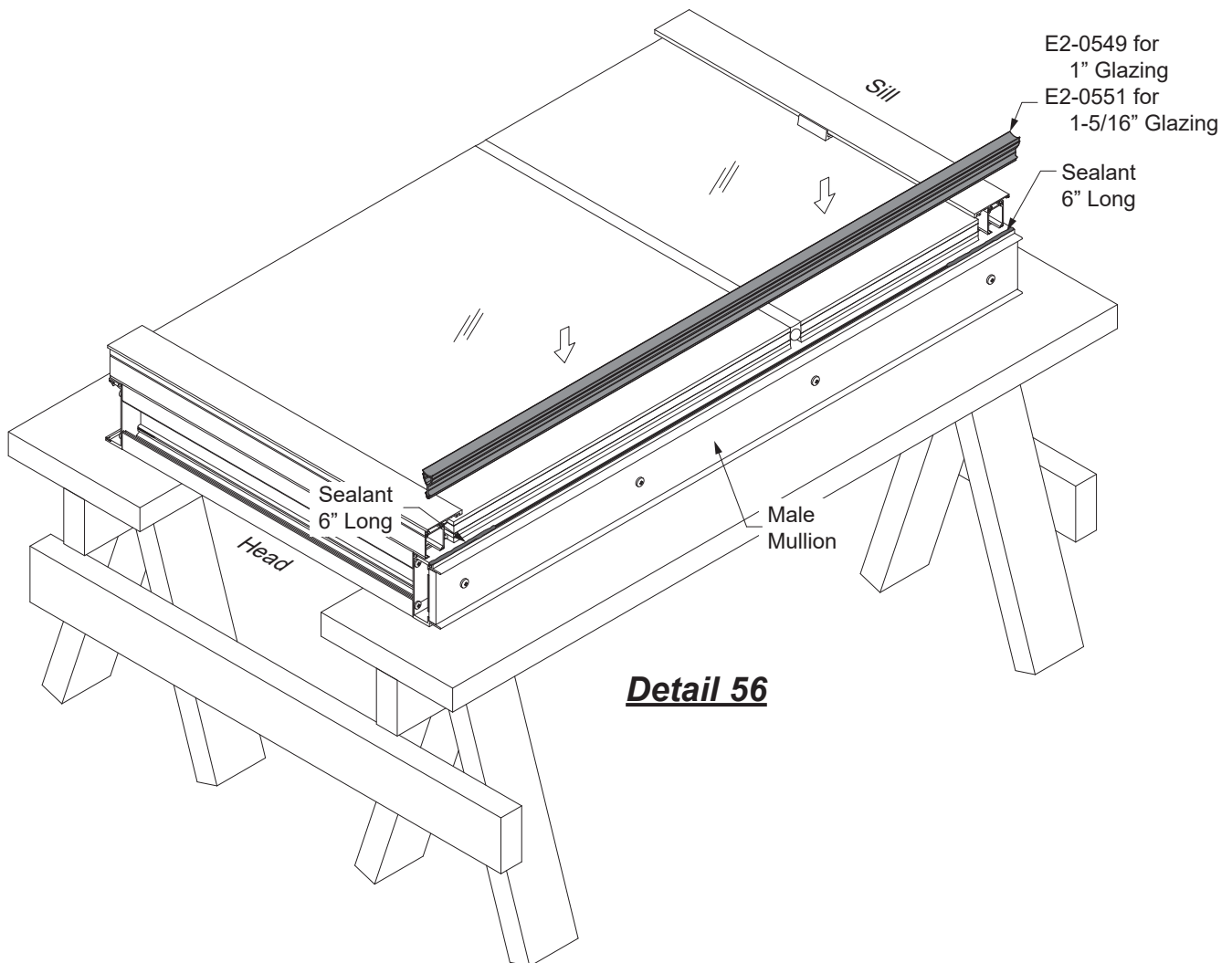

GLAZING

**STEP 22
INSTALL VERTICAL WEDGE GASKET (FOR JAMB UNIT)**

- Cut the wedge gasket to frame height minus (-) 3-3/4".
- Notch each end of the gasket by 3/8" as shown in **Detail 57**.
- Insert the gasket into the exterior jamb glazing pocket, starting at the ends first and working towards the midpoint as shown in **Detail 58**.

Detail 57

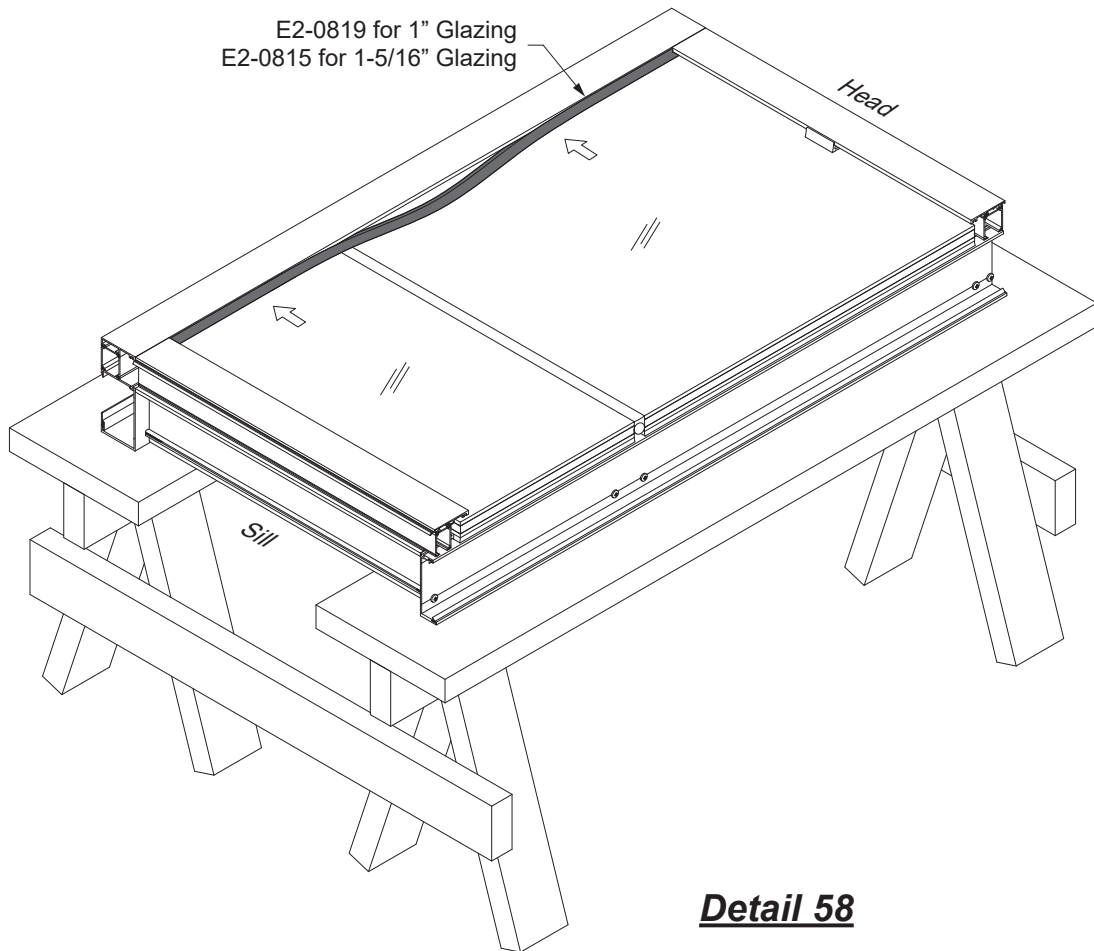
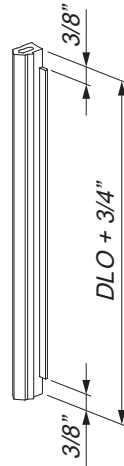

Detail 58

GLAZING

STEP 22 (Continued)

INSTALL HORIZONTAL WEDGE GASKET

- Cut the wedge gasket to the length of the glass stops.
- For jamb units apply sealant to the end of the wedge gasket where it meets the vertical gasket.
- Insert the wedge gasket into the exterior glazing pocket, centered on intermediate units, and tight against the jamb gasket at jamb units.

See **Detail 59**.

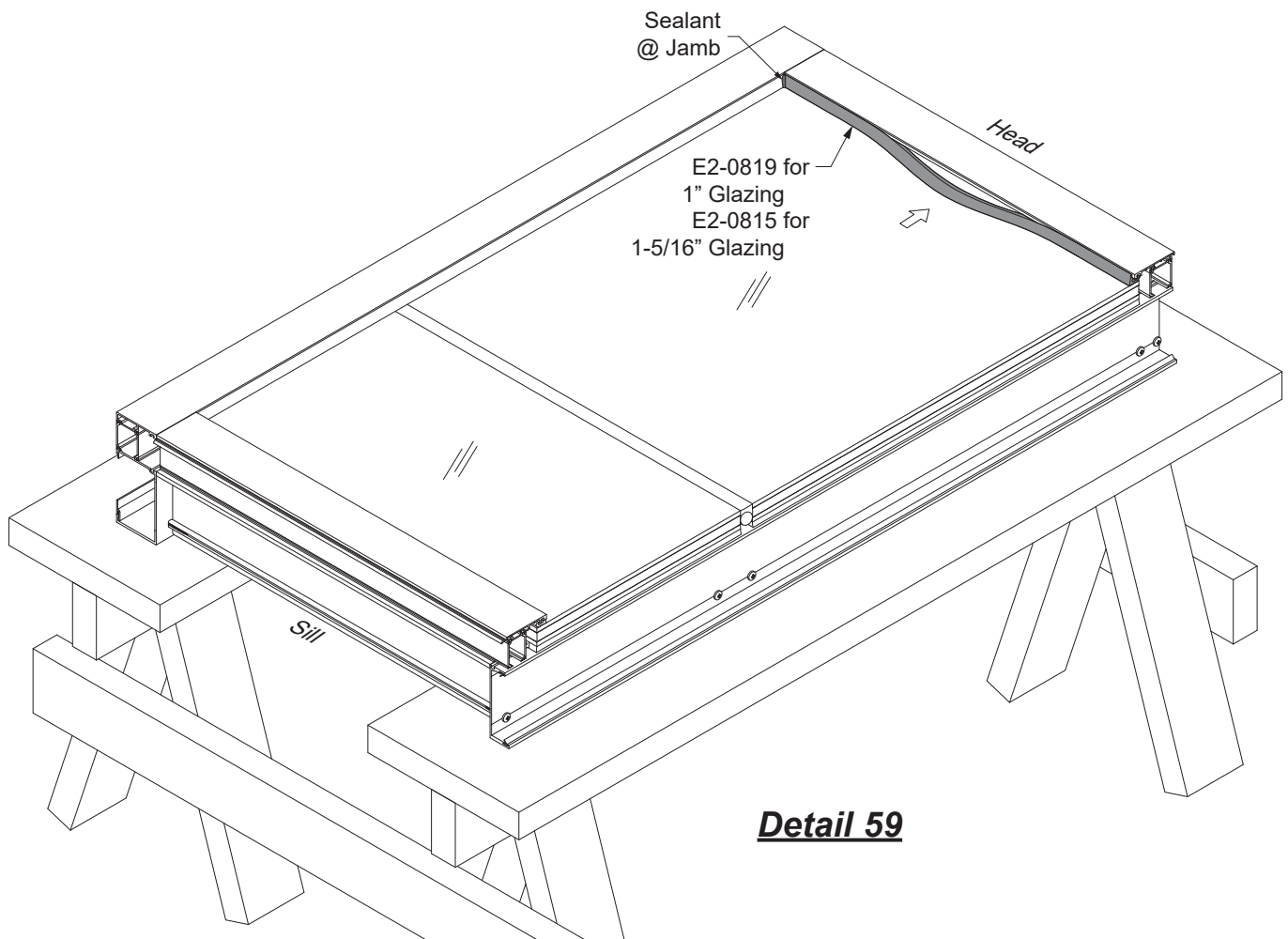

GLAZING**STEP 23
SEAL EXPOSED HORIZONTAL CAVITIES**

-Fill the head and sill glazing pockets at each SSG mullion with backer rods and sealant, ensuring exposed cavities at the head and sill are sealed. On mullions with the SSG rainscreen gasket, seal the exterior glass stops at the head and sill to the rainscreen gasket.

See **Detail 60**.

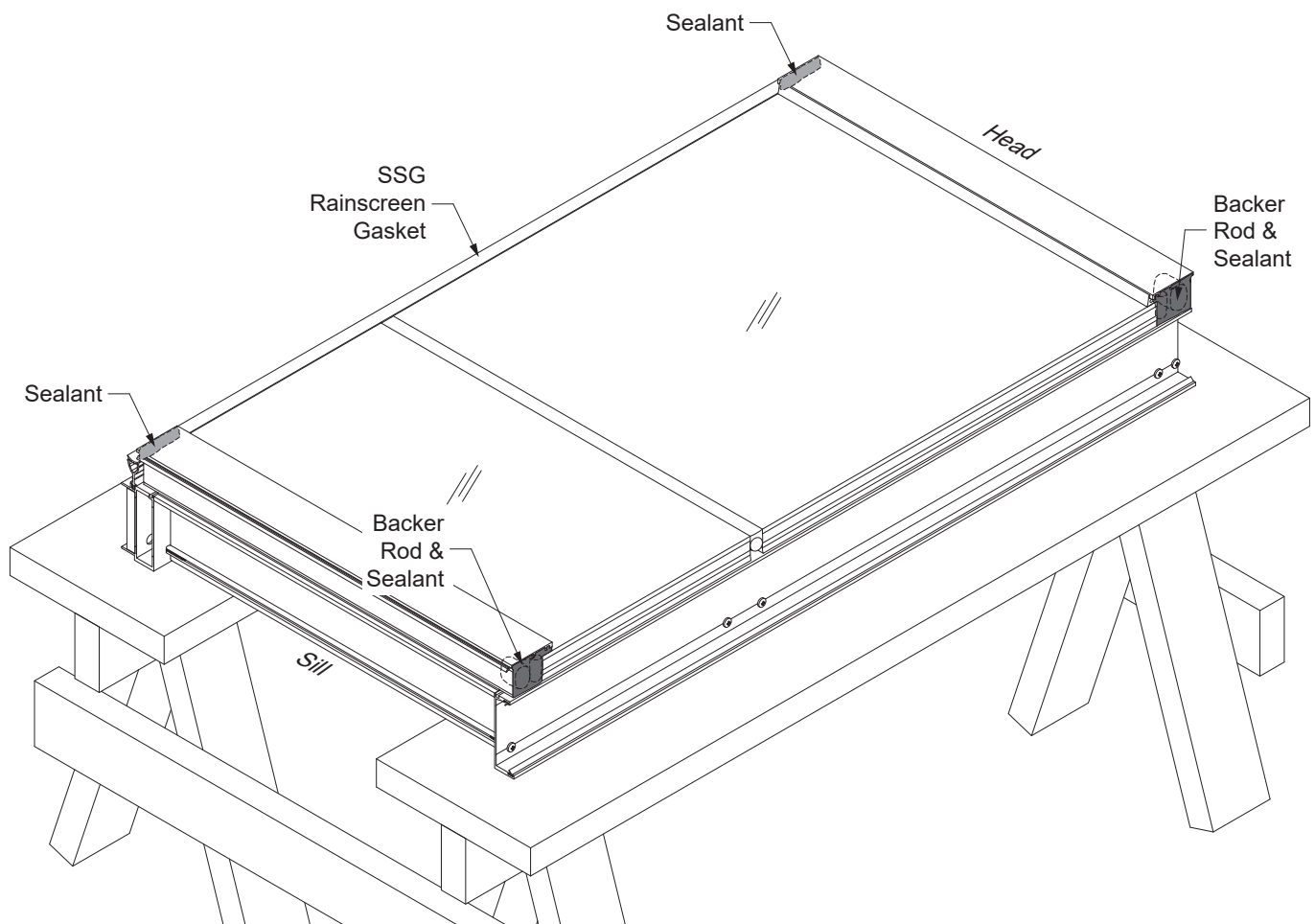

Detail 60

GLAZING

STEP 23A SEAL EXPOSED HORIZONTAL CAVITIES AT SSG CORNERS

-Apply Sealant to the mitered end of the horizontal exterior glass stops at the corner mullion to cover mill finished edges.

See **Detail 61**.

Note: Joint surfaces must be clean.

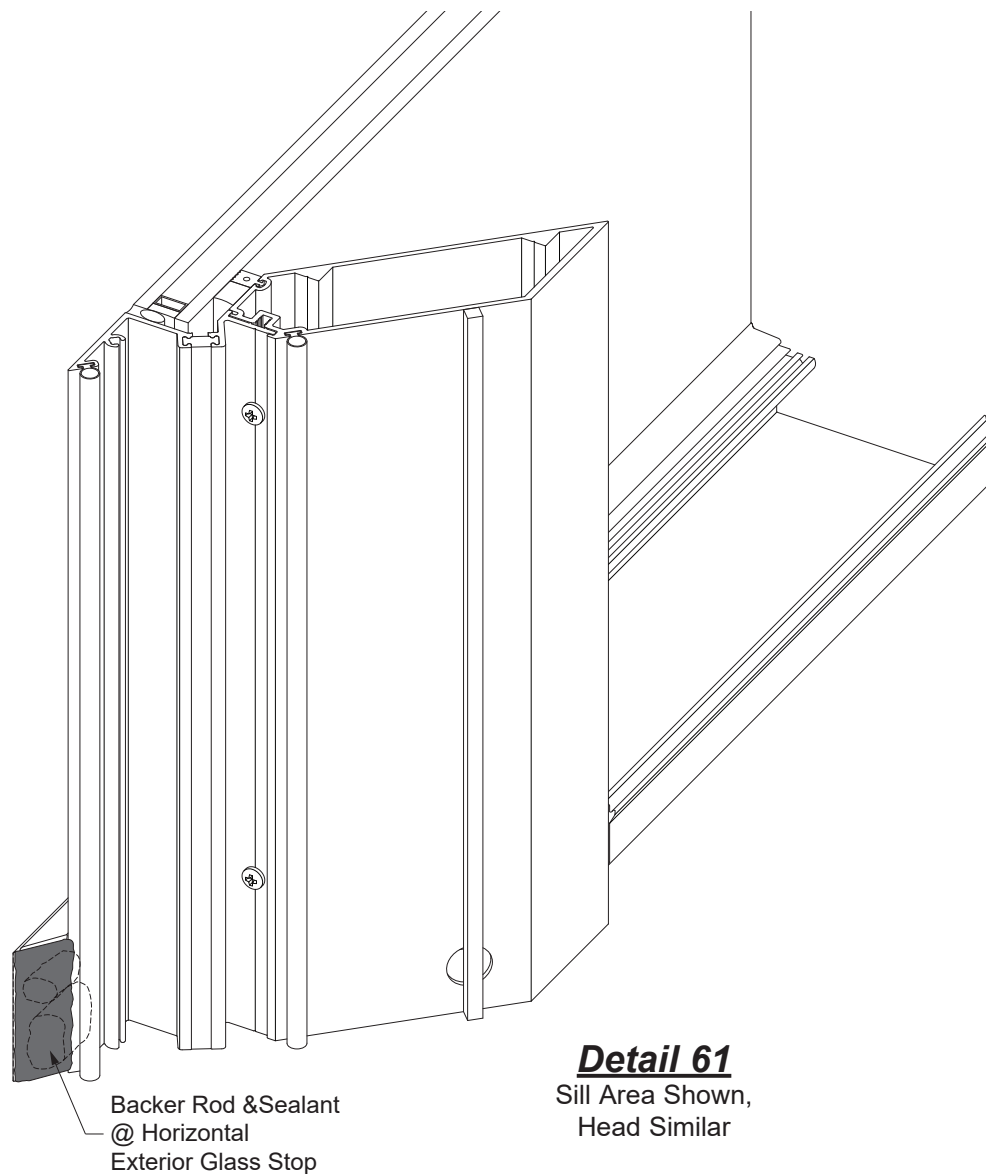

FRAME INSTALLATION

**STEP 24
INSTALL SILL FLASHING END DAMS**

-Bend the end dam tab left or right 90 degrees in order to “hand” the end dam for the left or right end of the flashing.

See **Detail 62**.

- Clean all joint surfaces using cleaner approved by sealant manufacturer.
- Apply sealant to the end of the sill flashing as shown in **Detail 63**.
- Slide the tab into the top portion of the sill flashing.
- Tap the tab into place with a small tool until the end dam is snug against the end of the flashing.
- Fasten the end dam to the sill flashing with two UA-1212 screws, starting at the back, followed by the front as shown in **Detail 63**.
- Tool sealant along the joint between the end dam and the sill flashing as shown in **Detail 64**.

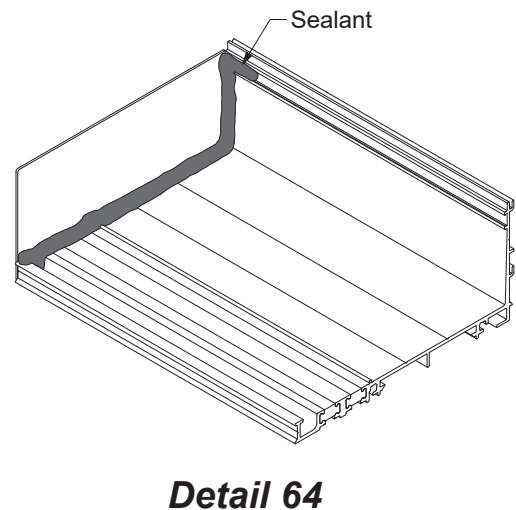
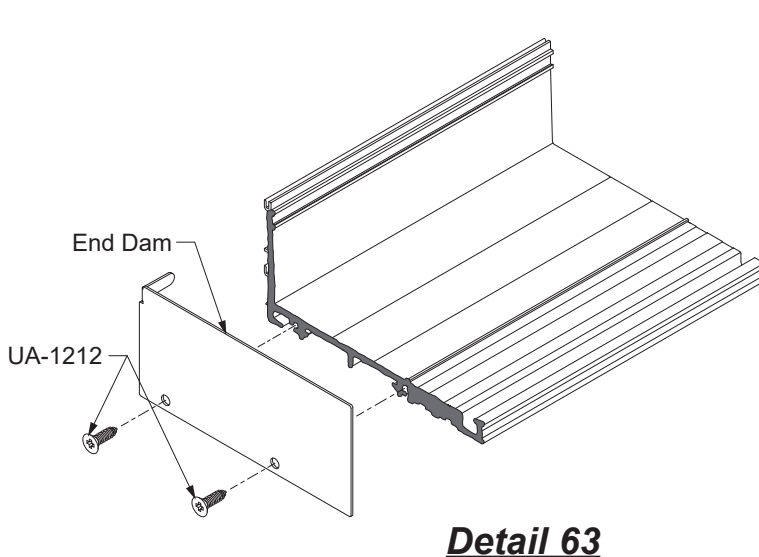
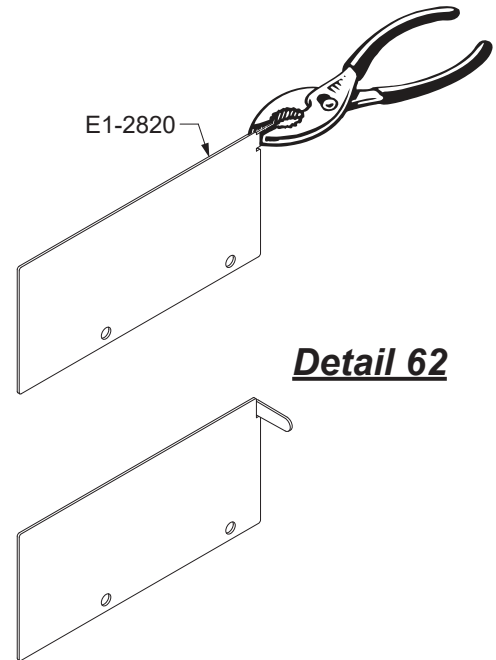

FRAME INSTALLATION

STEP 24A INSTALL SILL FLASHING END DAMS FOR SLAB EDGE COVER

- Sill flashings with slab edge covers will require an aluminum plate adaptor E9-8222 to be attached prior to field installation.
- Cut (2) E2-0065 weathering gaskets to length of the plate adaptor plus(+) 12". This will account for shrinkage.
- Insert the weathering gaskets into the reglets of the adaptor, leaving 6" on each side, and in the fin up orientation as shown in **Detail 65**.
- Slide the slab edge adaptor onto the sill flashing.

- Installation of the E1-1196 end dam is the same as illustrated in the previous page, except that the end of the installed slab edge adaptor will also require sealant.
- Fasten an E1-1196 end cap onto the slab edge assembly using an additional UA-1212 screw.

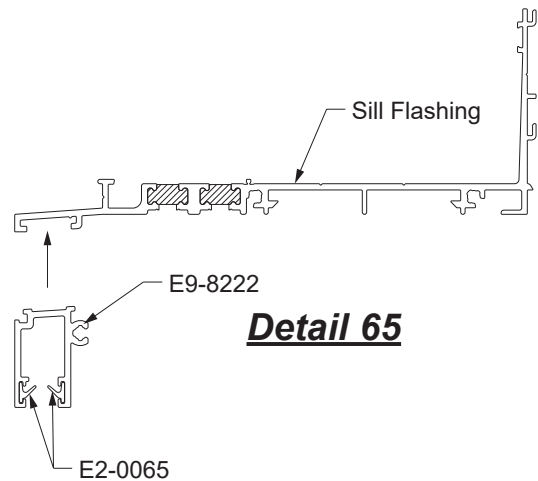

See **Detail 66**.

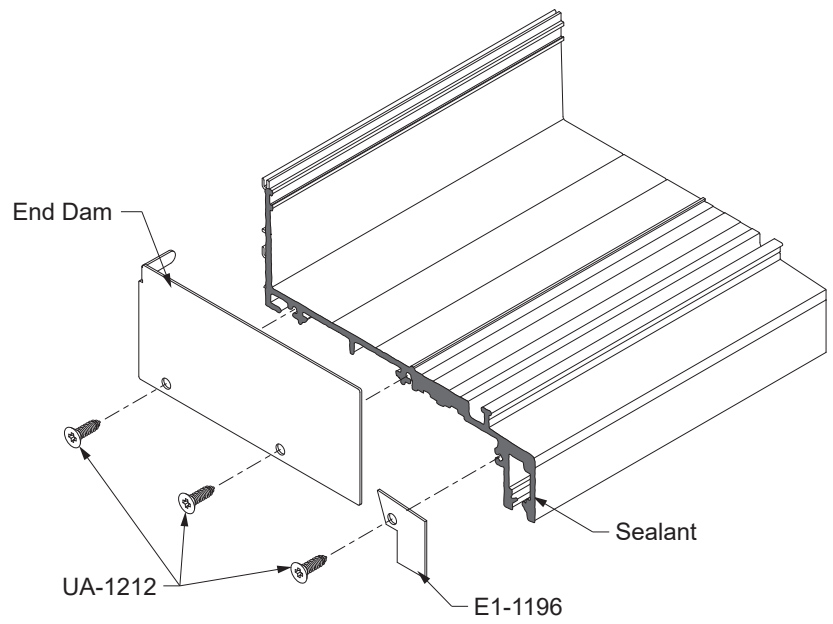

FRAME INSTALLATION

**STEP 25
INSTALL BE9-2729 SILL FLASHING**

- Install the sill flashing with a minimum of 3/8" shim space underneath. Sill flashing must be installed level.
- Anchor the sill flashing to the structure a maximum of 4" from each end and then 18" to 24" on center or per P.E. calculations.
- Apply and tool sealant to cover the heads of all anchors and screws.

**STEP 26
INSTALL SILL FLASHING SPLICE SLEEVE**

- Remove the nub with a chisel or pliers on both sides of the splice joint 1-1/2" as shown in **Detail 67**.
- After the sill flashing has been shimmed and anchored to the building structure, insert a small backer rod under the sill flashing as shown in **Detail 68**.
- Position the Silicone Splice Sleeve against the back wall below the groove.
- Bend the Silicone Splice Sleeve into the front on the channel as shown. Mark and cut the sleeve at this position.
- Clean Sill Flashing and Silicone Splice Sleeve with isopropyl alcohol at the splice location.
- Seal the flashing at the splice location as shown in **Detail 56**, before positioning the flashing. Set the Silicone Splice Sleeve into the sealant.
- Tool sealant tight as shown in **Detail 68**, squeezing the sheet flat with a seam roller.

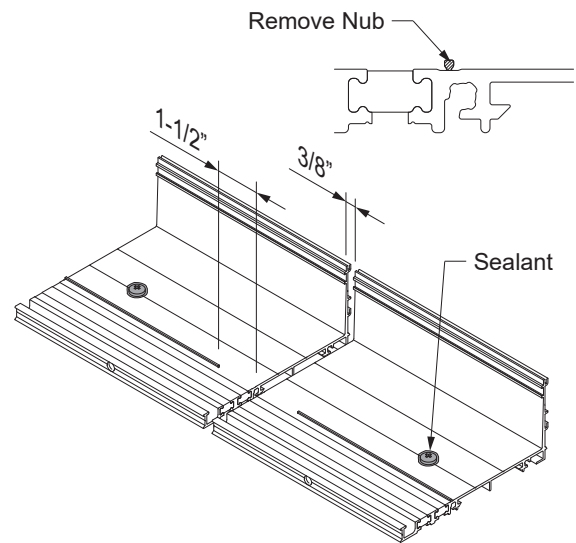

Detail 67

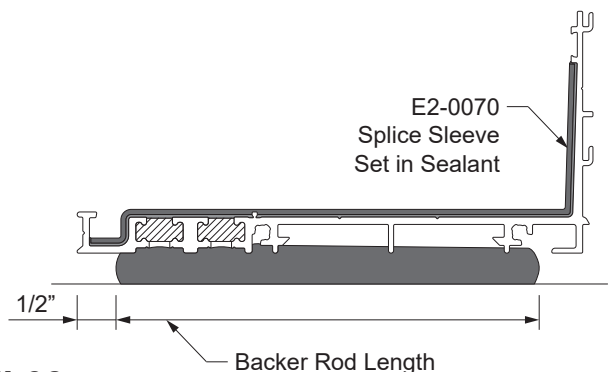
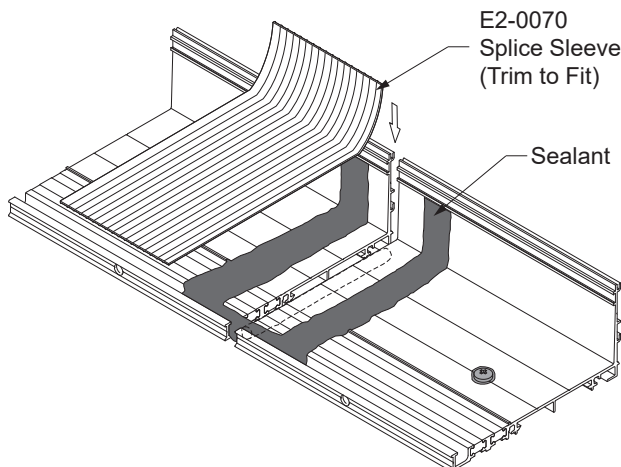

Detail 68

FRAME INSTALLATION

STEP 26 (Continued)
INSTALL SILL FLASHING SPLICE SLEEVE

-Thoroughly seal the small joint directly in front of the Silicone Splice Sleeve as shown in **Detail 69**.

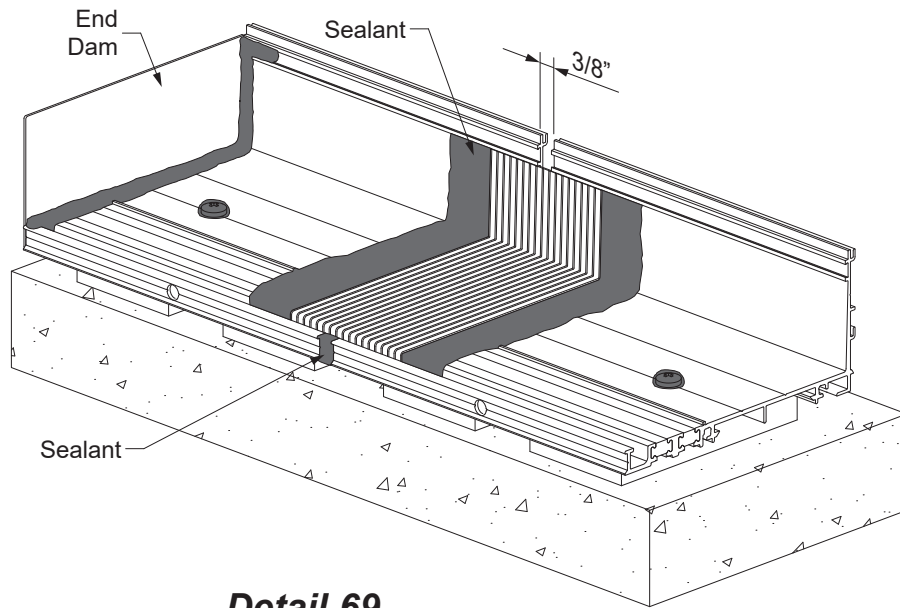

FRAME INSTALLATION

**STEP 27
SLAB EDGE COVER INSTALLATION**

Slab edge covers are installed from the head of the lowest elevation on upward. The head receptors are installed first, then slab edge plates, then the BE9-6330 sill flashings with the E9-8222 slab edge adaptors.

**STEP 27A
INSTALL HEAD RECEPTOR END DAMS & WEATHERING GASKETS**

- Cut the E2-0051 airtight gasket to head receptor length plus 3/16" at each end for the splice joint, and insert it into its reglet for both the receptor and snap cover as shown in **Details 70 & 70A**.
- Cut the E2-0065 slab edge weathering gaskets to head receptor length. Insert the gaskets into the slab edge reglets in the fin down orientation as shown in **Details 70A**.

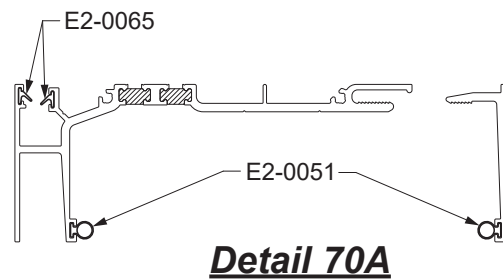
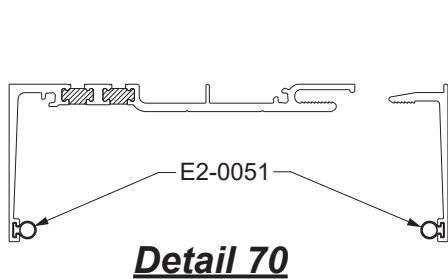

- Clean all joint surfaces using cleaner approved by sealant manufacturer.
- Apply sealant to the end of the head receptor as shown in **Detail 71**.
- Fasten the end dam to the head receptor with two UA-1212 screws, starting at the back, followed by the front.
- Tool sealant along the joint between the end dam and the end dam as shown in **Detail 71**.
- Tape down the top corners to hold the end cap in place until the sealant cures.

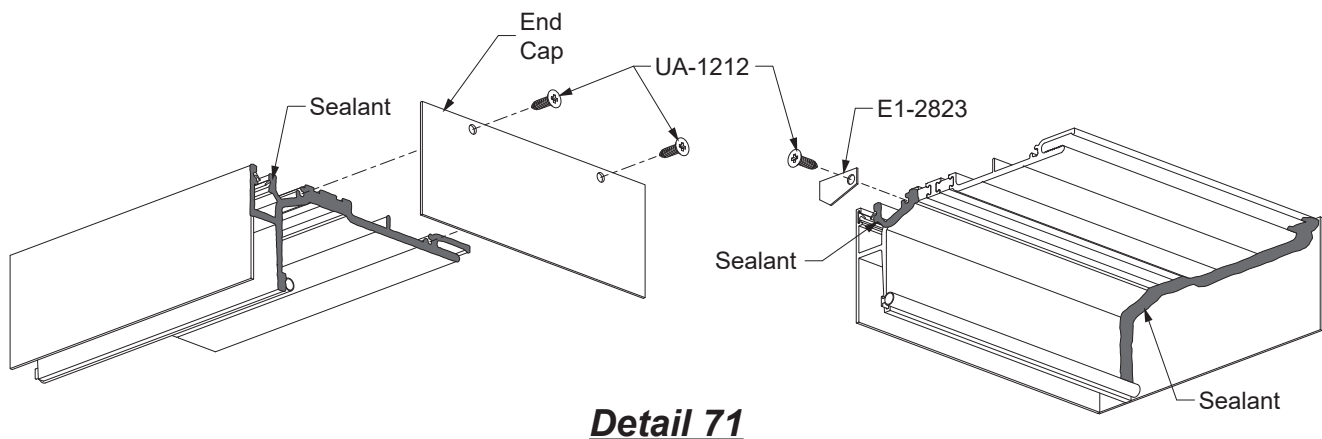

FRAME INSTALLATION

STEP 27B INSTALL HEAD RECEPTOR

- Starting at the smallest opening height, install the head receptor with a minimum of 1/2" shim underneath. Head receptor must be installed level.
- Anchor the head receptor to the structure according to approved shop drawings and or P.E. calculations.
- Apply and tool sealant to the heads of all fasteners as shown on **Detail 72**.

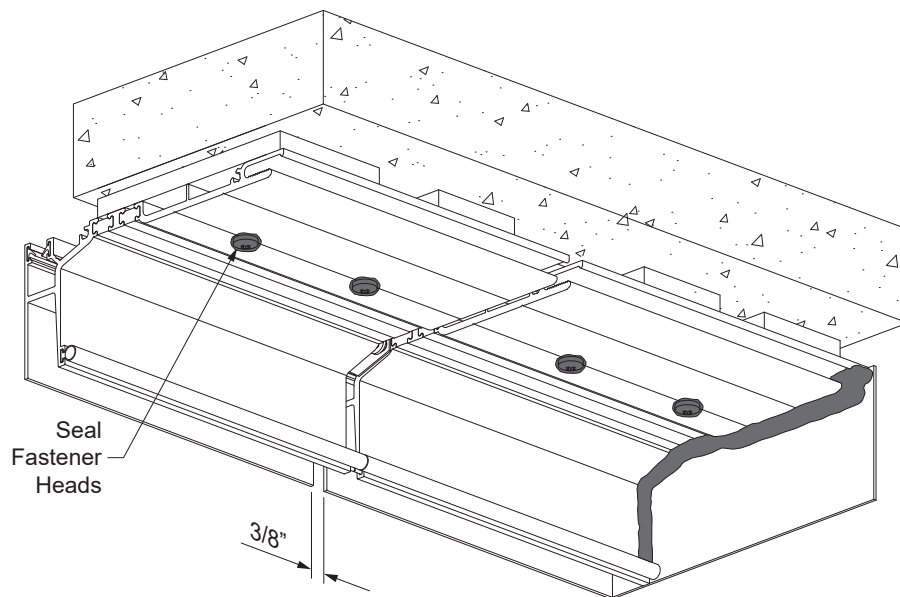

Detail 72

FRAME INSTALLATION

**STEP 27B (Continued)
INSTALL HEAD RECEPTOR**

- Prior to installing the Silicone Splice Sleeve, clean head receptor and Splice Sleeve with isopropyl alcohol at the splice location.
- Position the Splice Sleeve, E2-0070, against the front wall inside the head receptor, set in sealant centered on the splice joint as shown in **Detail 73**. Trim as necessary to fit.
- Tool the sealant. Use a seam roller to press the sheet tight against the receptor.
- Seal the ends of the E2-0051 gasket together at the splice.

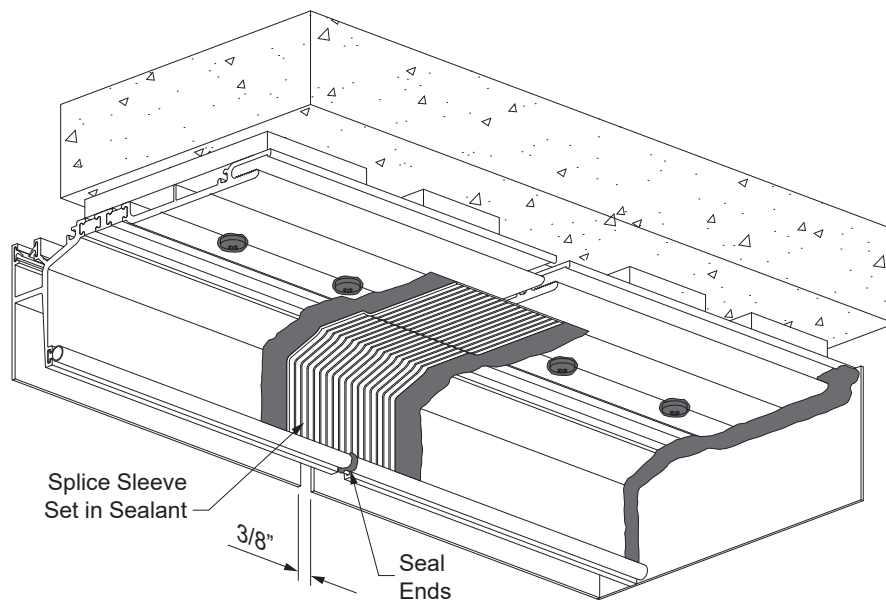

Detail 73

FRAME INSTALLATION

STEP 27B (Continued)
INSTALL HEAD RECEPTOR SPLICE SLEEVE

-At the exterior joint of the head receptor, position an E1-9961 splice sleeve centered on the splice joint. Set the splice sleeve in sealant, similar to the procedure previously outlined for the underside of the head receptor.

See **Detail 74**.

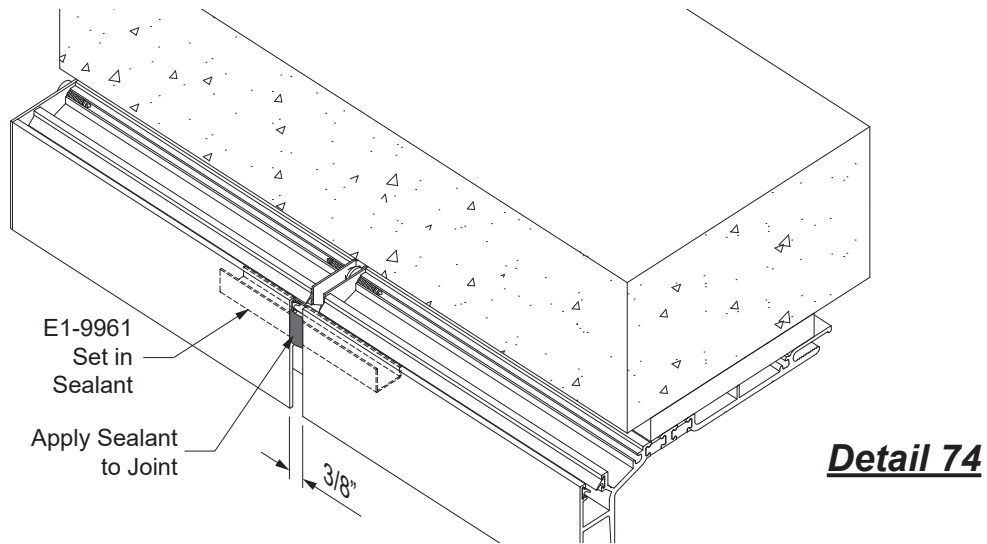

- Install E2-0054 setting blocks at 1/4 points of the aluminum plate.
- Install a weep baffle, E2-0099, over every weep hole location.
- Do not install the snap cover yet.

See **Detail 75**.

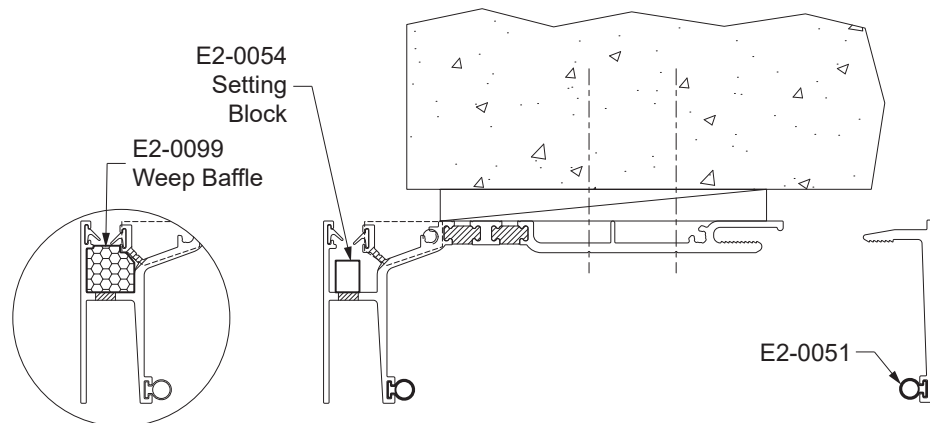

Detail 75

FRAME INSTALLATION

**STEP 27C
ASSEMBLE SLAB EDGE COVER PLATES**

- Clean the ends of the slab edge cover and attachment areas of end caps using a cleaner approved by sealant manufacturer.
- Apply and tool sealant to each end of the slab edge cover prior to attaching the end caps.
- Attach end caps to each end of the slab edge cover using (2) UA-1212 fasteners.
- Tool and wipe away any excess sealant at the joints.

See **Detail 76**.

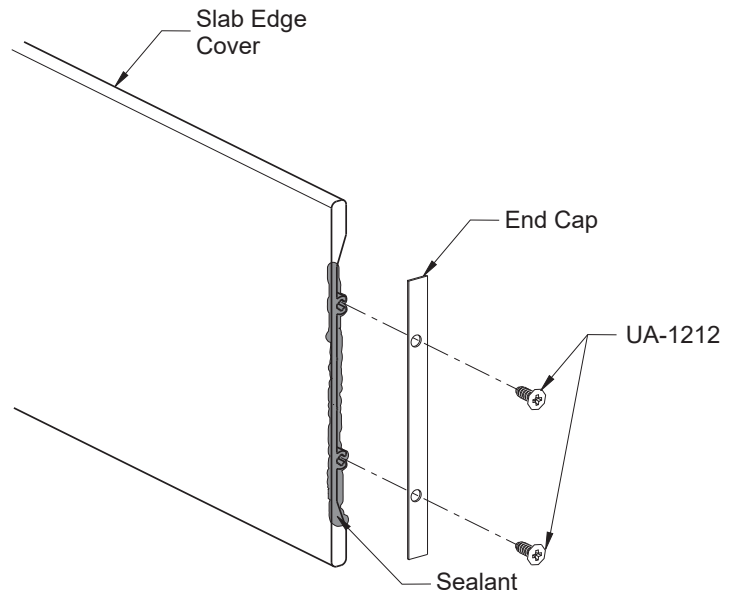

Detail 76

**STEP 27D
INSTALL SLAB EDGE COVER FASCIA**

- Prior to installing the slab edge cover, insert a continuous backer rod, and apply and tool sealant to the front underside of the slab edge, between the head receptor and the substrate.
- Slide the slab edge cover plate into the head receptor receptacle, seating it on top of the setting blocks.
- Be sure to leave a 3/8" joint between the plates for runs longer than 24'-0".

See **Detail 77**.

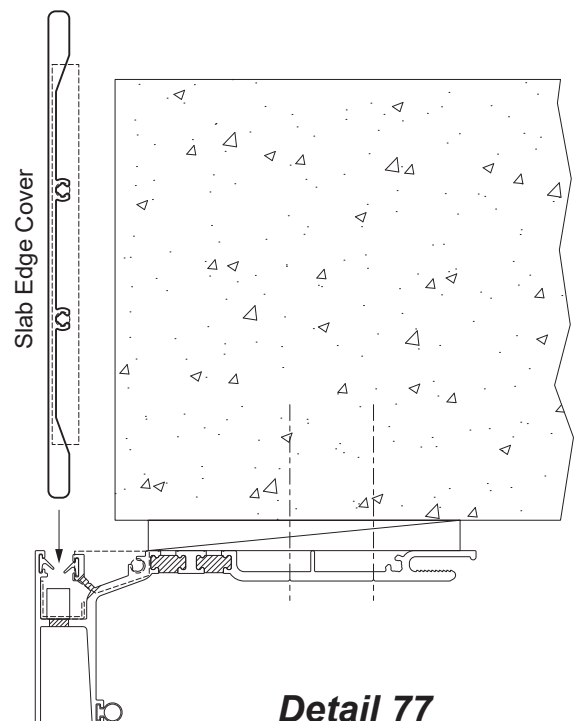

Detail 77

FRAME INSTALLATION

STEP 27E (Continued)

INSTALL SILL FLASHING SPLICE SLEEVE AT SLAB EDGE

- Install the sill flashing assembly onto the substrate, with 1/2" minimum shim space, engaging the slab edge cover plates below and sealing all anchor fastener heads.
- Install the next slab edge sill flashing assembly onto the splice sleeve as shown in **Detail 78**. Be sure to leave a 3/8" splice joint between the sill flashing assemblies.

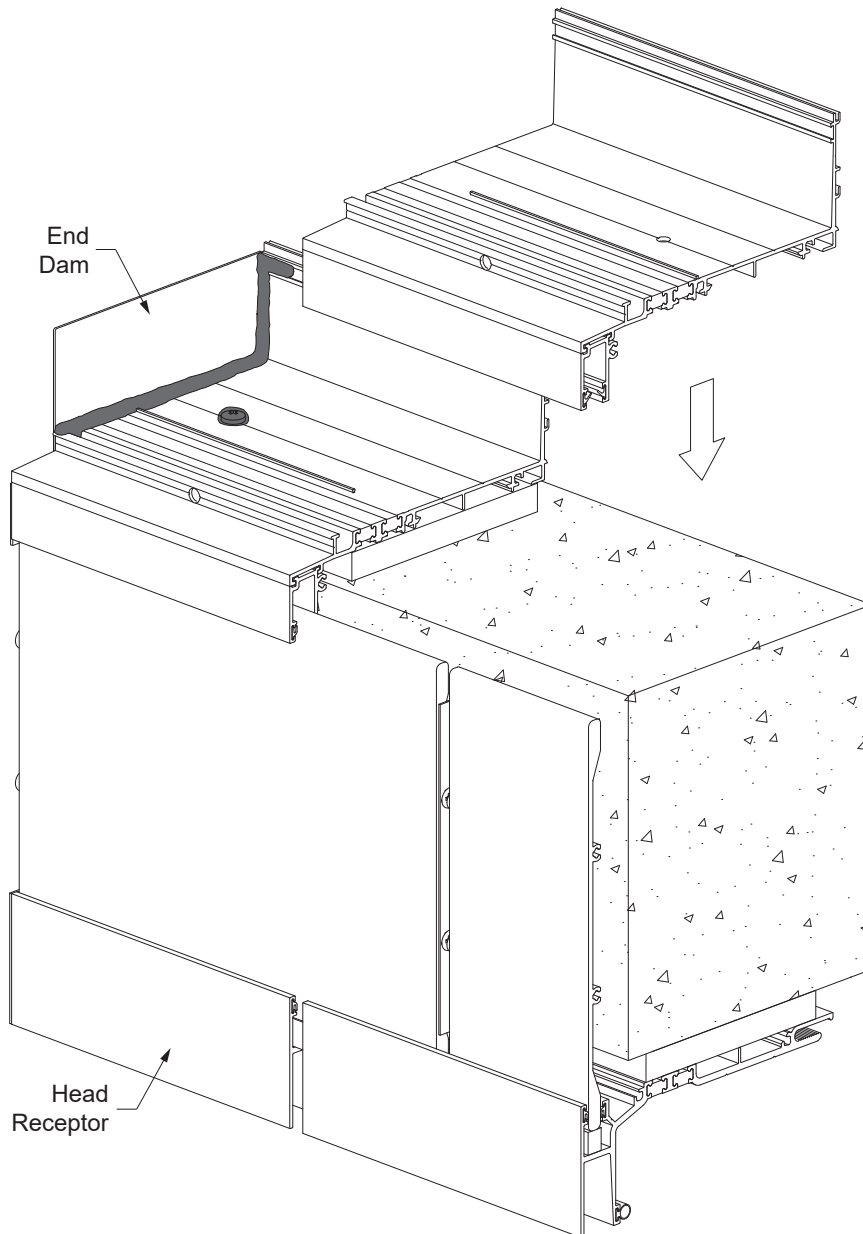

Detail 78

FRAME INSTALLATION

STEP 27E (Continued)

INSTALL SILL FLASHING SPLICE SLEEVE AT SLAB EDGE

-Installation of the E2-0070 splice sleeve is the same as previously outlined in **Step 26**, except to apply sealant to the joint at the slab edge cover plate, adaptor, and head receptor as shown in **Detail 79**.

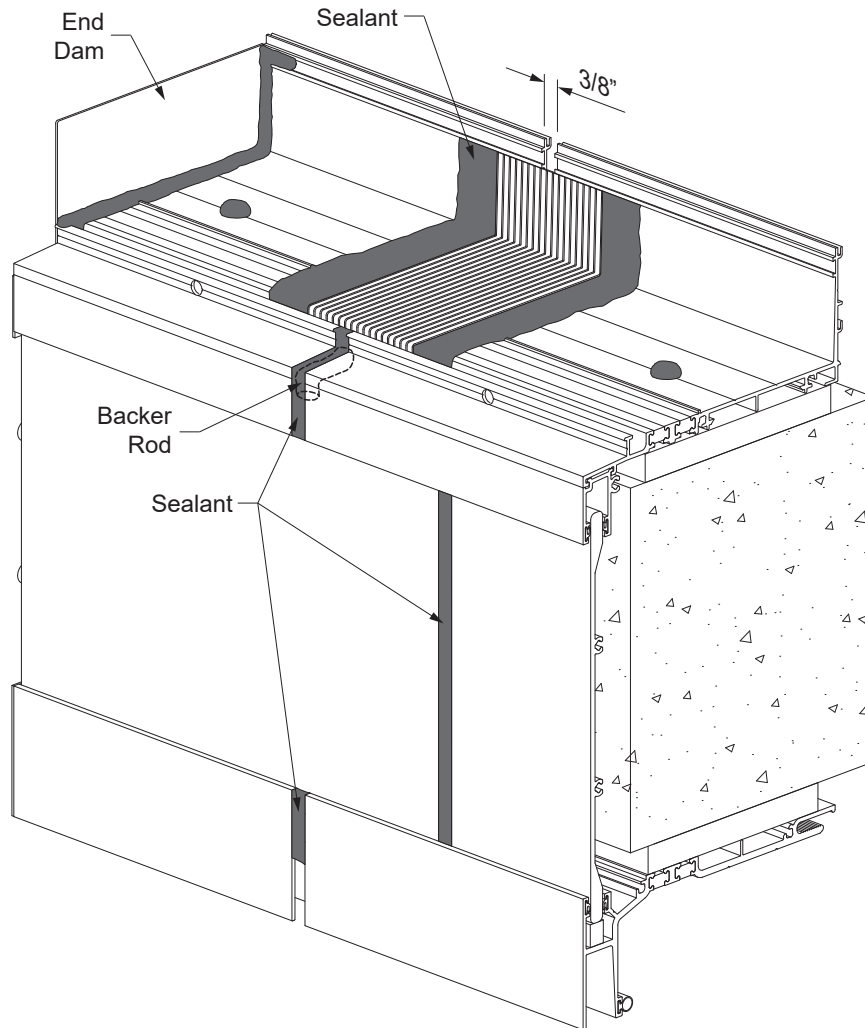

Detail 79

FRAME INSTALLATION

STEP 28
INSTALL SILL FLASHING AT CORNERS

- Cut two 18" minimum long pieces of BE9-6328 sill flashing and miter (45° for 90° corners) as shown in **Detail 80**.
- Align the two pieces at the corner condition with the mitered ends pushed together tight and anchor the sill flashing as indicated on the approved shop drawings and or P.E. calculations.
- Apply and tool sealant to the mitered joint and anchor heads.

See **Detail 80**.

- Continue installing the rest of the sill flashing providing a 3/8" expansion joint at splices as shown in **Page 53 to 54**.

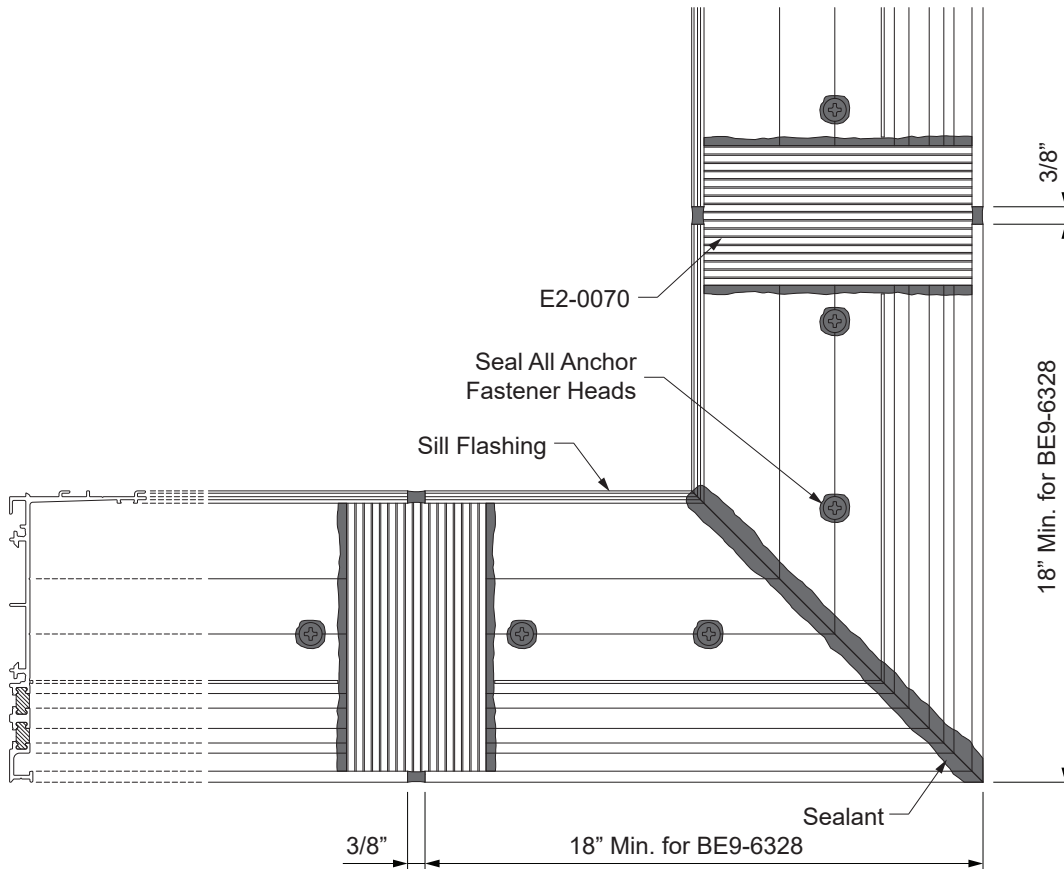

Detail 80

FRAME INSTALLATION

STEP 28A

INSTALL SILL FLASHING FOR SLAB EDGE COVER AT CORNERS *

- Cut two 19-3/16" minimum long pieces of BE9-6330 sill flashing and E9-8222 slab edge cover adaptor, and miter (45° for 90° corners). The head receptor that is to be installed below will also receive the same miter cut fabrication.
- Install the head receptor using similar procedure as previously described for the sill flashing.
- Miter cut the slab edge cover plates 45° for 90° corners, such that upon installation, they leave a 1/2" gap at the corner.
- Fasten end caps onto the edge of the slab edge cover plates.
- Install the slab edge plates onto the setting blocks of the head receptor below.
- Align the two pieces of the BE9-6330 sill flashing at the corner condition with the mitered ends pushed together tight and anchor the sill flashing as indicated on the approved shop drawings and or P.E. calculations.
- Apply and tool sealant to the mitered joint and anchor heads.

See **Detail 81**.

- Continue installing the rest of the sill flashing providing a 3/8" expansion joint at splices as shown in **Pages 53 to 61**.

* **Note:** Similar technique required for head receptor.

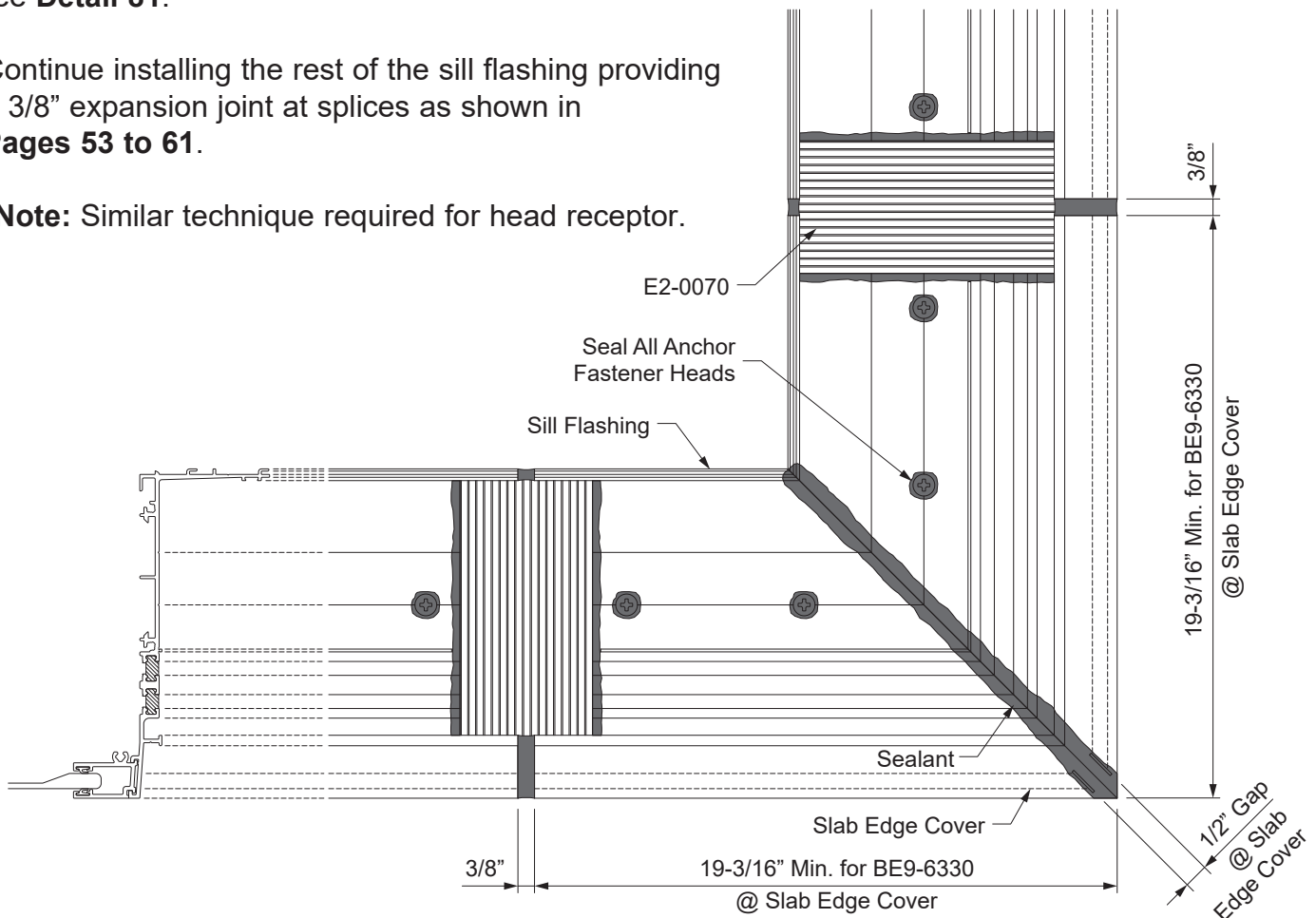

Detail 81

FRAME INSTALLATION

STEP 29 SILL PREPARATION

At every splice condition, apply bond breaker tape to the back of the sill member before the joint is sealed between the sill and sill flashing.

See **Detail 82**.

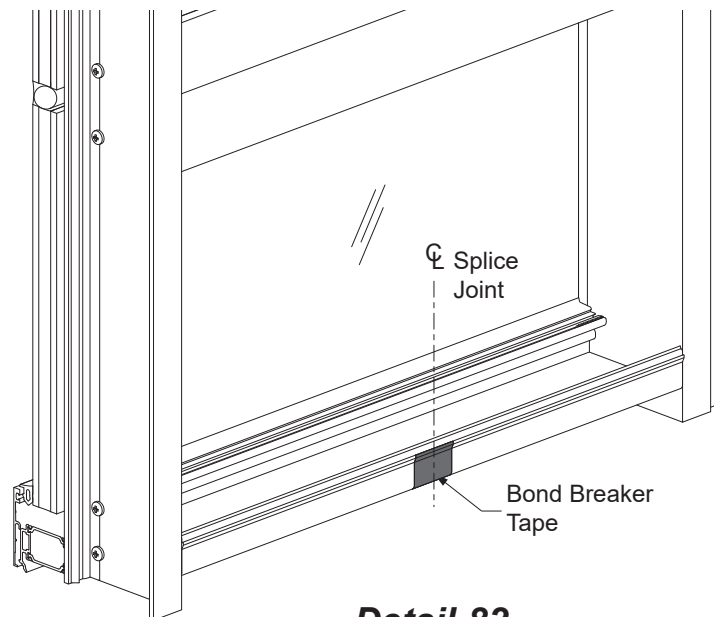

Detail 82

FRAME INSTALLATION

**STEP 30
INSTALL FRAMES**

- The male mullion half of the second unit engages into the female mullion half of the previously installed unit, from the side, as shown in **Detail 83**.
- For frames that utilize the E1-2830 channel shaped head anchor, secure the anchor to the head using masking tape as shown in **Detail 84** prior to installation into the frame opening.
- Set the frame into place. See **Detail 85** for shim space at head.
- Taking care to ensure the framing unit is plumb, level, square, and true, anchor the framing unit to the substrate, first at the head using fasteners as specified by engineering calculations.

See **Detail 85**.

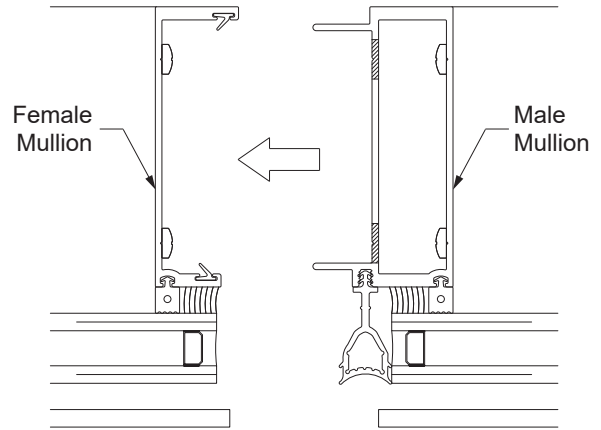

Detail 83

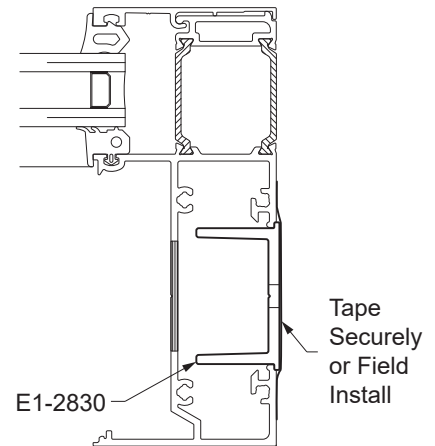

Detail 84

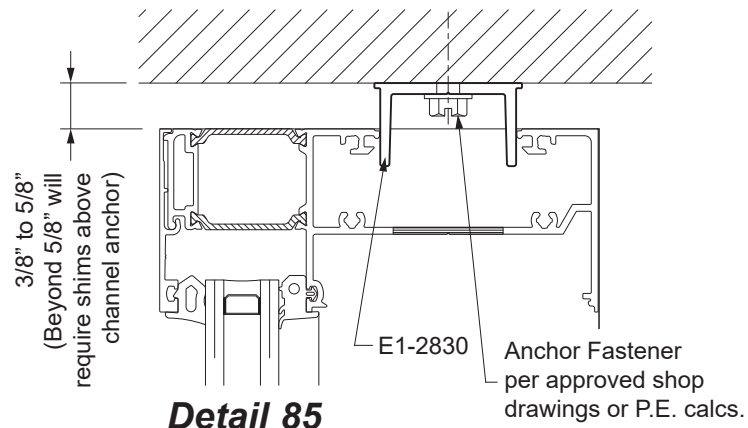

Detail 85

FRAME INSTALLATION

STEP 30 (Continued) INSTALL FRAMES WITH HEAD RECEPTOR

- Set the frame into place, taking care to ensure the unit is plumb, level, square, and true.
- Snap on the E9-6343 receptor snap cover with the E2-0051 airtight gasket onto the head receptor.

See **Detail 86**.

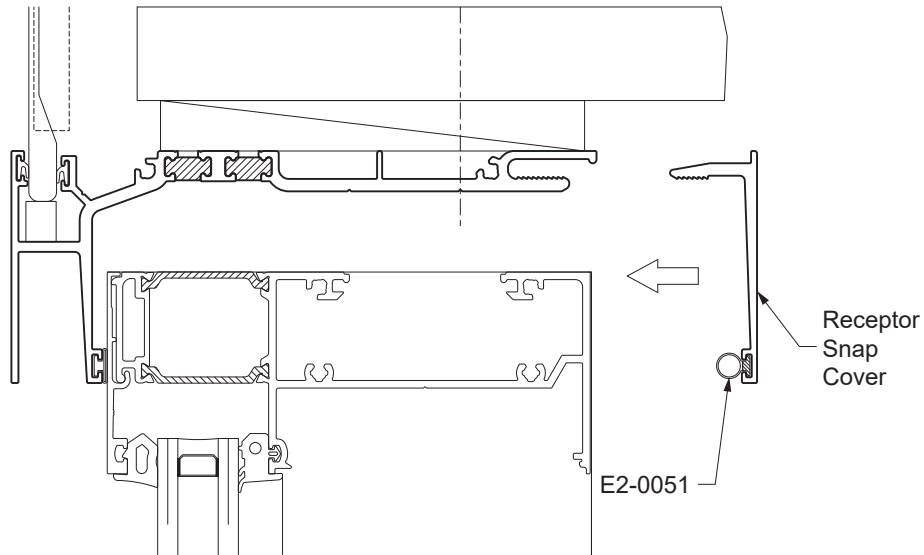

Detail 86

FRAME INSTALLATION

**STEP 30 (Continued)
APPLY CORNER MULLION SPACER TAPE**

-For the first unit at the corner, apply E2-0110 spacer tape to the corner mullion, the full height of the mullion as shown in **Detail 87**. Do not apply the spacer tape to the corner mullion of the adjoining unit.

INTERIOR

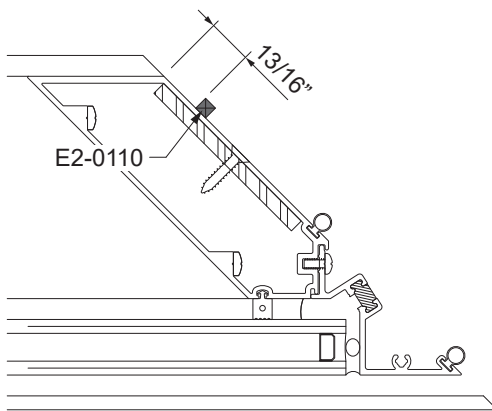

EXTERIOR

INTERIOR

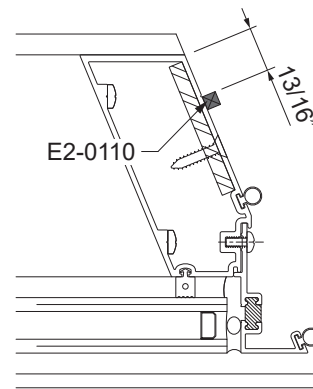

EXTERIOR

Detail 87

INTERIOR

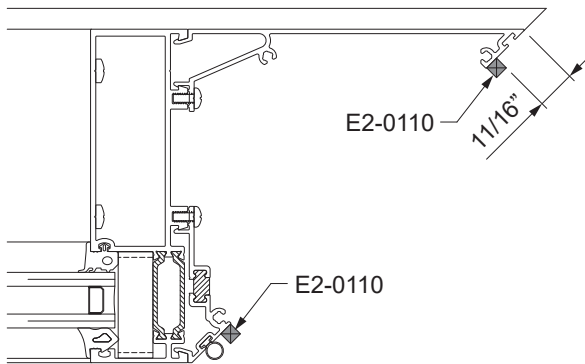

EXTERIOR

INTERIOR

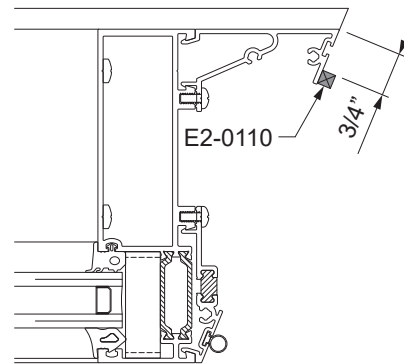

EXTERIOR

FRAME INSTALLATION

STEP 30 (Continued)
INSTALL FRAMES

Note: If sill has not fully engaged into the sill flashing, tap down with a block of wood to ensure proper engagement prior to fastening. See **Detail 88**.

-Just prior to installing the next unit, apply sealant to the interior reglet of the female mullion where it will interface with the male mullion of the installed unit (from bottom of mullion and 6" up.) Also, apply 6" of sealant to the sill flashing centered on the mullion centerline (3" at the jamb) as shown in **Detail 89**.

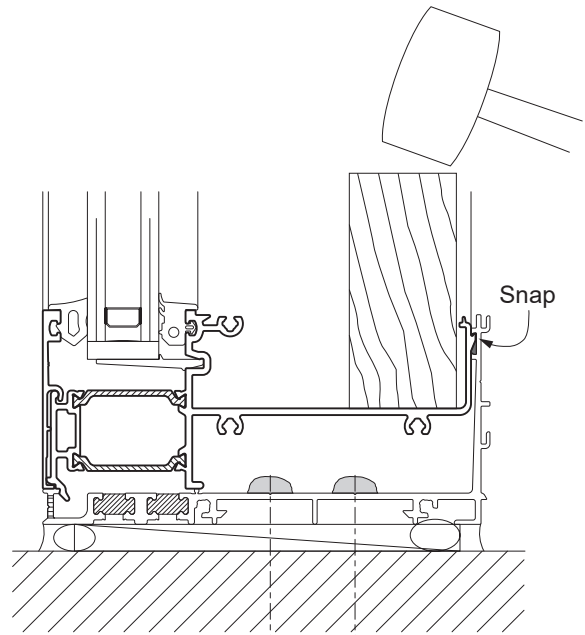

Detail 88

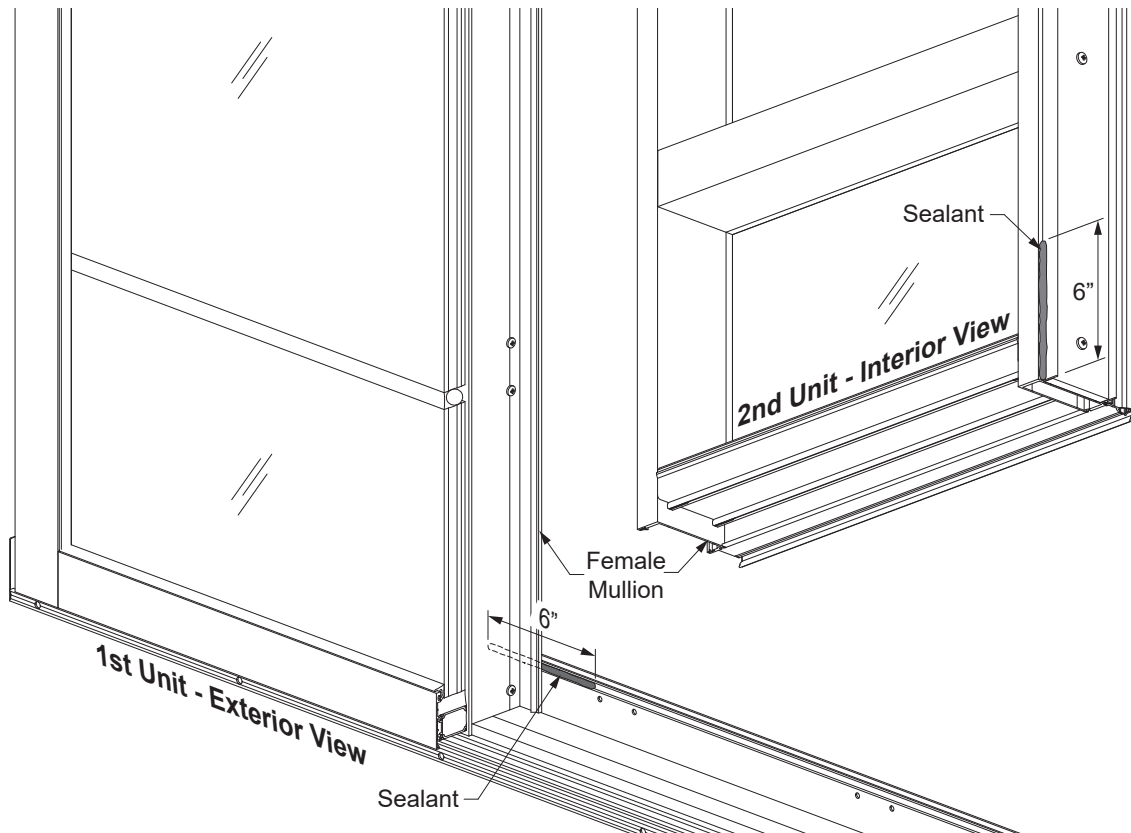

Detail 89

FRAME INSTALLATION**STEP 30 (Continued)
INSTALL FRAMES**

-Once the unit is set in place, use the holes in the back of the sill flashing to as pilot holes for 0.161” diameter tap holes in the sill. Fasten the sill into the back of the sill flashing with PC-1008-SS fasteners.

-Apply and tool sealant to both the fastener heads and the fastener threads at the back of the sill member.

See **Detail 90**.

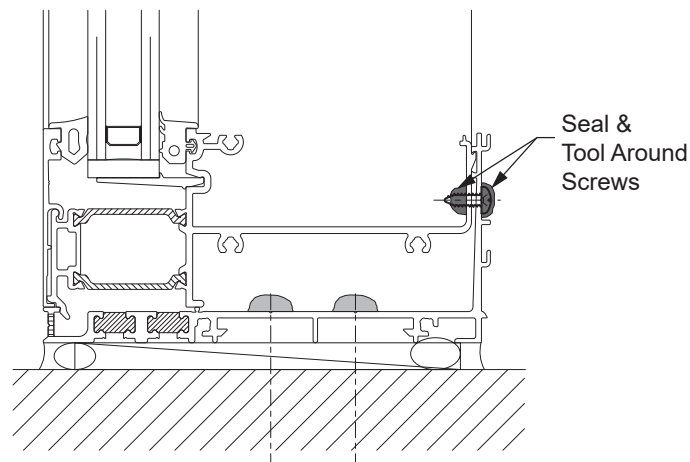

Detail 90

FRAME INSTALLATION

STEP 30 (Continued)
INSTALL FRAMES

-Install the next framing unit, taking care to ensure that the unit is plumb, level, square, and true, and that the female mullion fully interfaces with the male mullion from the previous unit.

See **Detail 91 & 91A**.

-Fill the void between the two units at the back of the sill flashing with sealant. See **Detail 92**.

-Repeat **Step 30** until all units are installed.

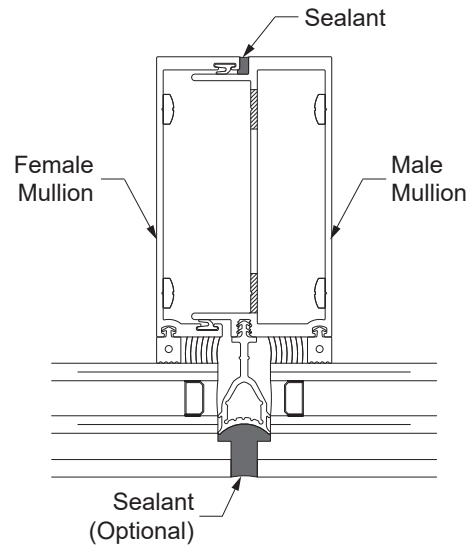

Detail 91

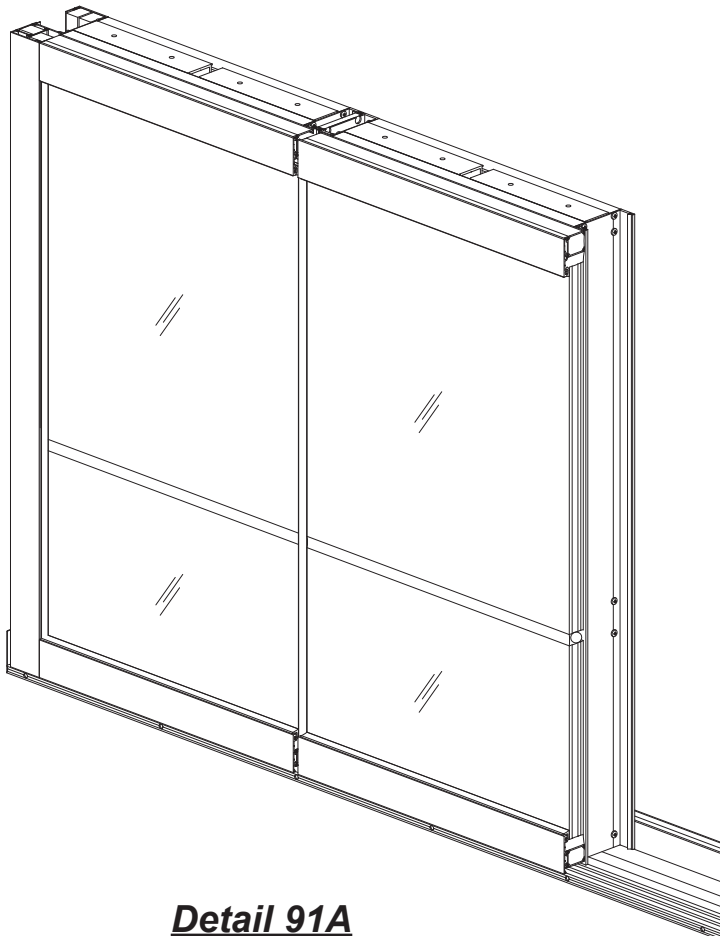

Detail 91A

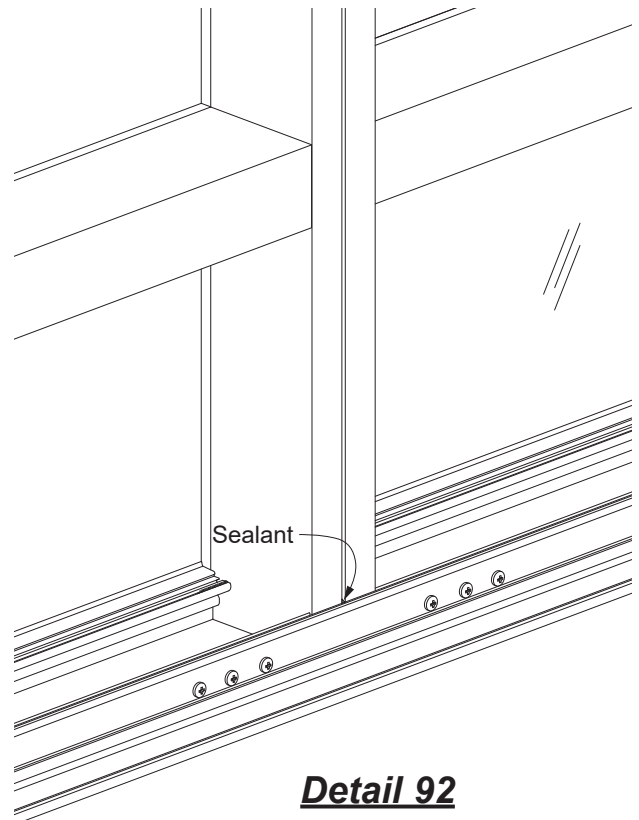

Detail 92

FRAME INSTALLATION

**STEP 31
APPLY PERIMETER SEALANT**

- Once all the units are installed, apply perimeter sealant required on interior and exterior of the window wall system.
- Install backer rod around the perimeter of the frame.
- Apply perimeter sealant to the joint between the frame and the structure.
- Avoid getting sealant into the sill flashing weep holes.

See **Detail 93**.

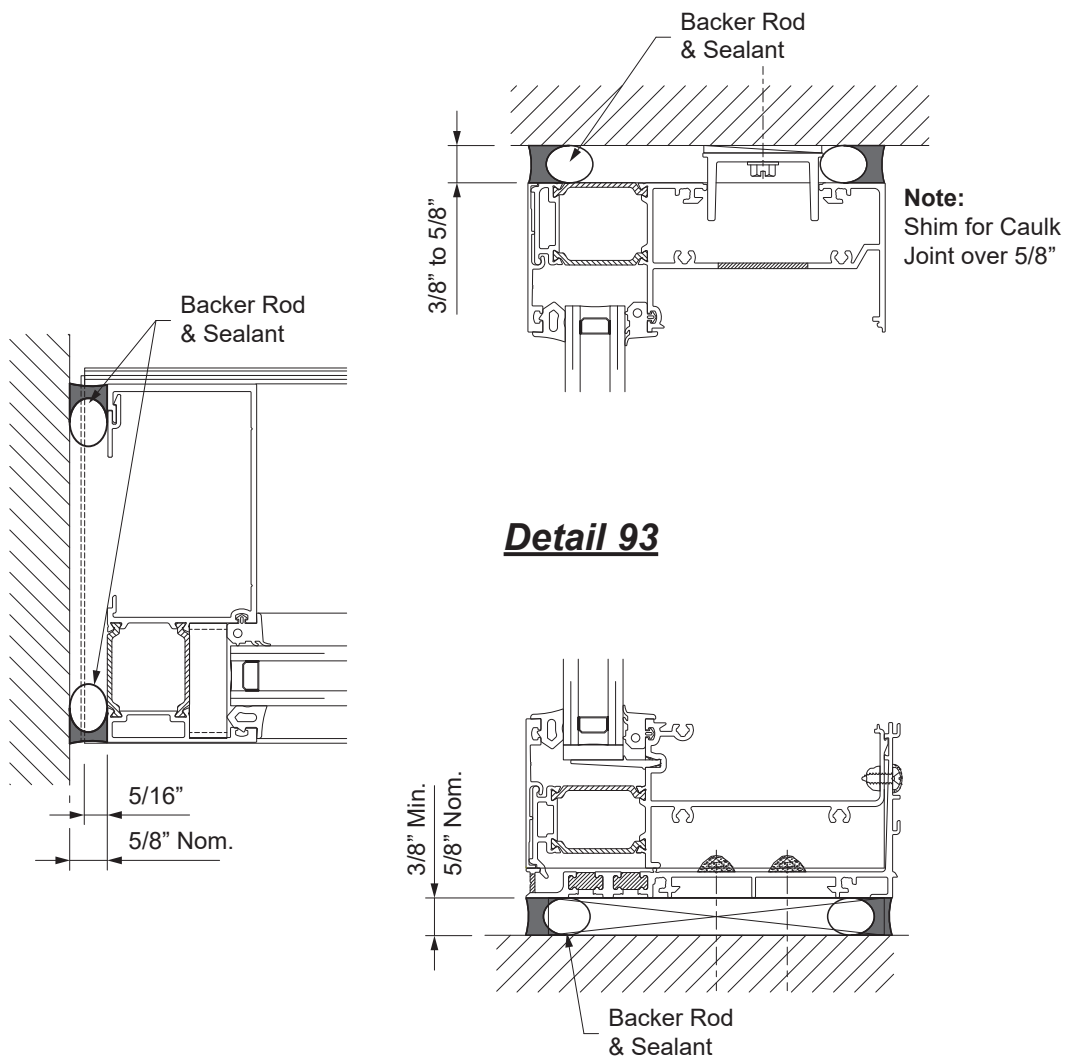

Detail 93

FRAME INSTALLATION

STEP 31A

APPLY PERIMETER SEALANT AT SLAB EDGE COVERS

- For slab edge covers at the head and sill, install a backer rod and apply sealant to the back of the sill flashing and head receptor.
- Tool sealant prior to skinning over.
- Install a backer rod and seal the jamb edge of the slab edge covers.

See **Detail 94**.

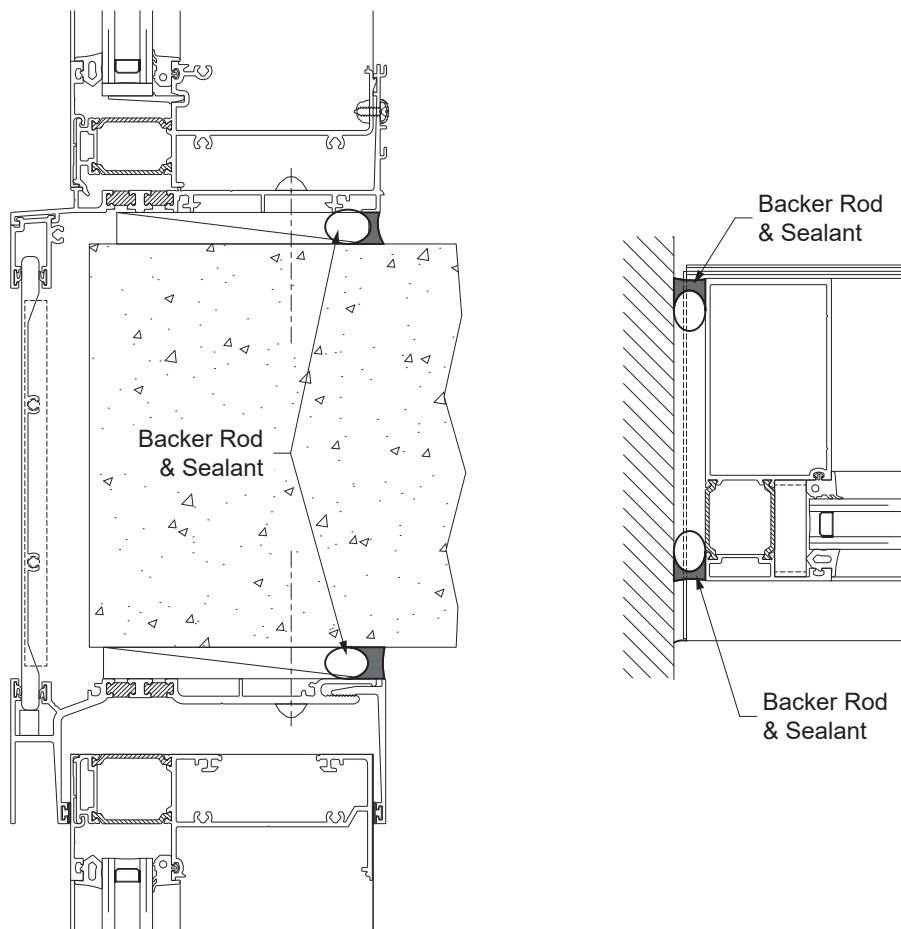

Detail 94

FRAME INSTALLATION**STEP 32
SEAL HEAD ANCHOR ACCESS HOLES**

Note: This is for only when E1-2830 channel anchors are used at the head.

-To plug the anchor access holes, apply sealant on the underside surface around the perimeter of the access hole. Then immediately insert the plug. Apply and tool sealant completely over and around the plug after inserting and seating in place.

See **Detail 95**.

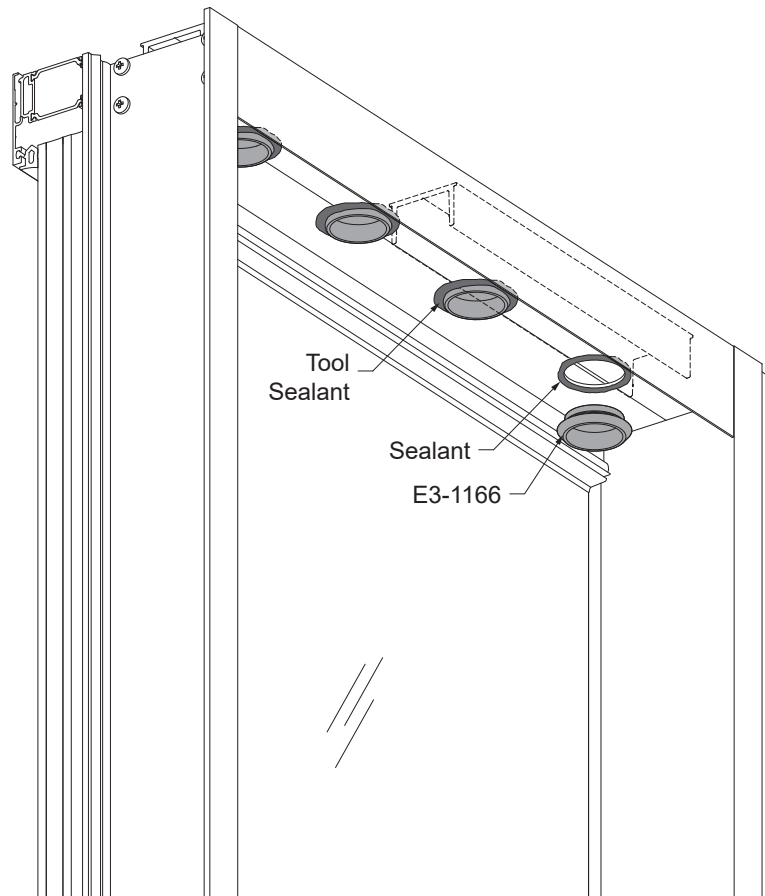

Detail 95

FRAME INSTALLATION

STEP 33
APPLY SEALANT AT CORNER MULLIONS

-Apply backer rod and sealant the at the interior of the corner mullion, the full height of the mullion.
Do not seal the exterior side of the adaptor.

See **Detail 96**.

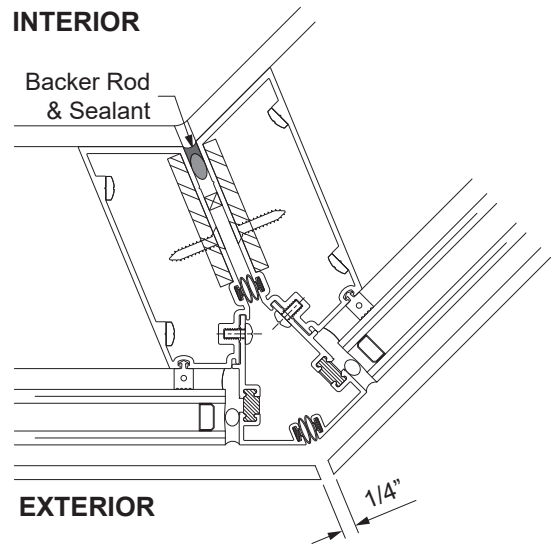
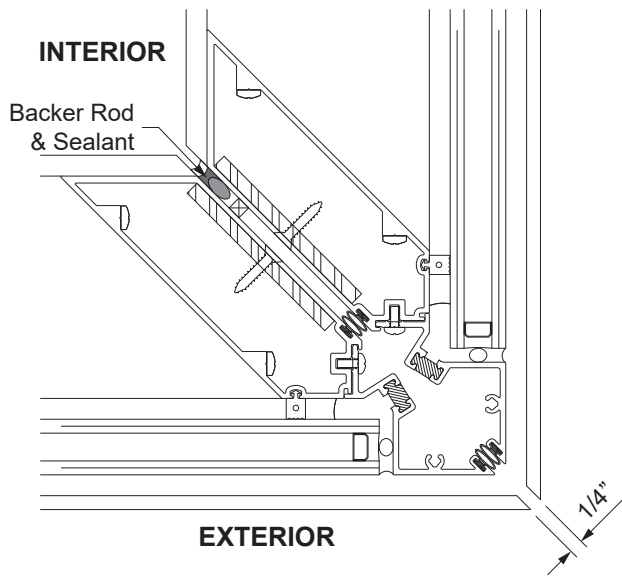

Detail 96

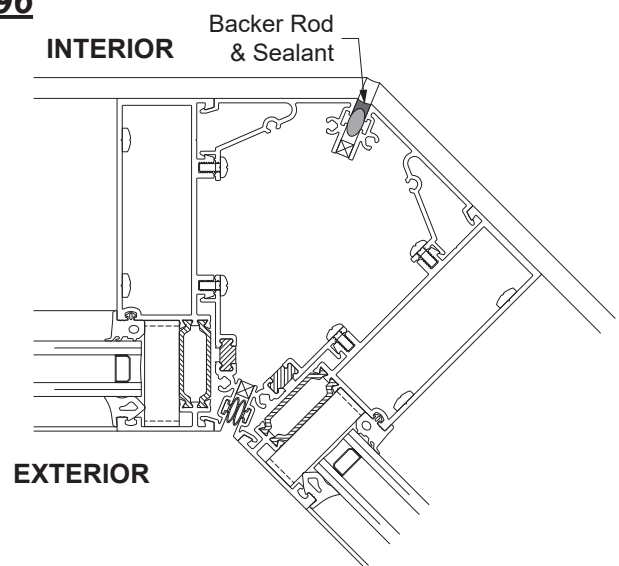
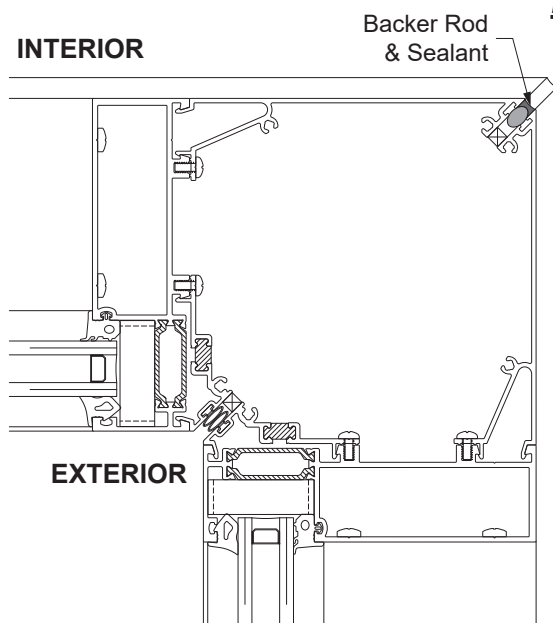

FRAME INSTALLATION

**STEP 34
INSTALL INTERIOR COVERS**

-Immediately prior to installing the interior covers, apply continuous sealant to top of the sill at the sill flashing across the sill.

-Snap on the interior covers at the head, horizontals, and sills.

E9-6339 IG head & IG horizontals
E9-6337 sill and OG head

-Snap on the E9-6342 face cover onto the interior of the sill flashing.

See **Detail 97**.

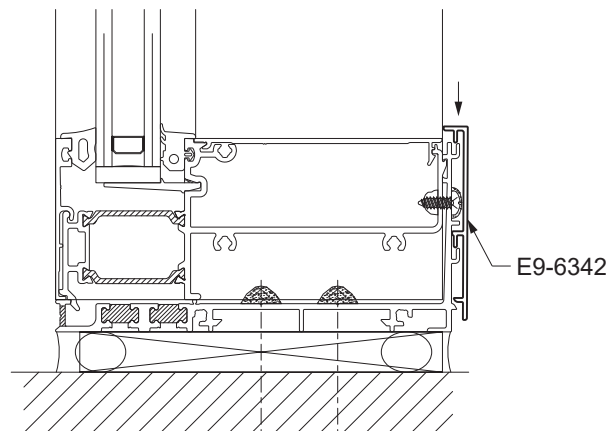
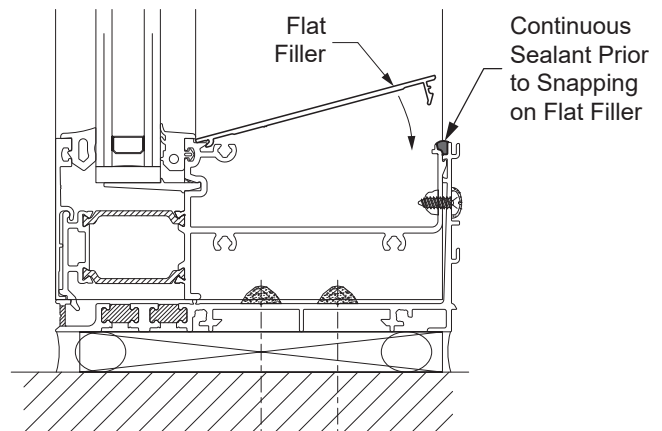

Detail 97

DOOR FRAME INSTALLATION

**STEP 35
INSTALL DOOR FRAME**

Doors are shipped assembled, and door frames will be fabricated and shipped knocked down. Please refer to the 20D, 35D, & 50D **Entrances Installation Manual** for door installation.

-Door jamb mullions are made from the BE9-6306 male and BE9-6308 female mullions for the preglazed application, shimmed and fastened together as shown below in **Detail 99**. Spacing of fasteners to be determined by approved shop drawings and or P.E. calculations. Door transoms bars are made with tubular horizontals and BE9-6365 pocket filler (cut to transom horizontal length minus(-) 1/32") and E9-6338 glass stop.

-Join the mullion halves together with a 7/8" shim and FC-1236 fasteners located at 2" from the back of the mullion.

-Install the BE9-6365 flat filler (cut to length and notched as shown in **Detail 99**) into the door jamb mullions.

-Install the E9-6338 glass stop and flat filler onto the transom bar.

-Install E1-2826 sill flashing end dams into the ends of the sill flashing using the same method as previously shown in **Step 24 on Page 42**.

See **Detail 99**.

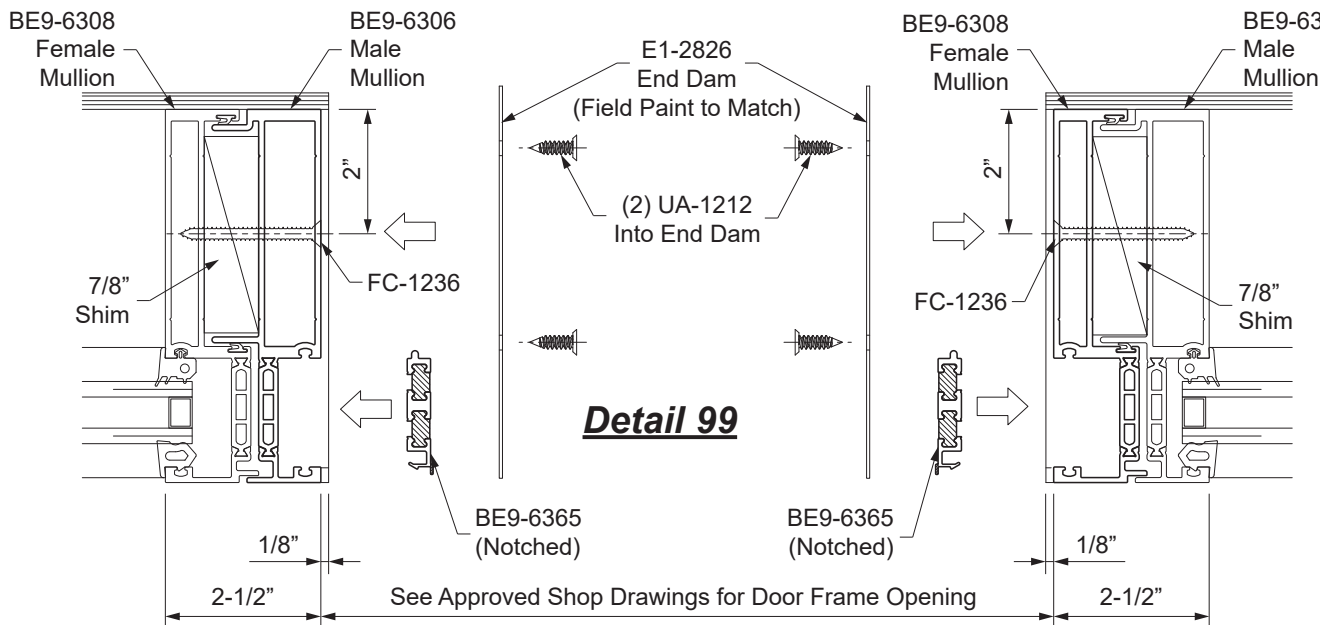
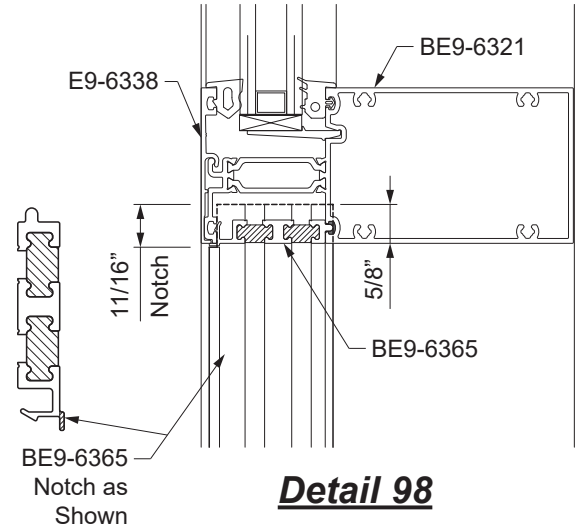

DOOR FRAME INSTALLATION

**STEP 35 (Continued)
INSTALL DOOR FRAME**

- Assemble the door subframe and install the door jamb subframes to the door jambs with PC-1228 fasteners, spaced according to the approved shop drawings and or P.E. calculations. Provide a 3/8" shim space between the jamb subframes and the jamb mullions, 1/4" shim space at the transom bar. Maintain a 5/8" inset between the subframe and the front of the window wall framing.
- Snap in the door stops into the door jamb subframes.

See **Details 100 & 101**.

- Install backer rods between the subframes and the window wall framing, both front and back. Apply and tool sealant to the backer rods to ensure a water-tight seal.

* **Note:** The 1-1/4" dimension is shown for when BE9-1526 jamb subframe is used. This dimension may vary if other subframes are used.

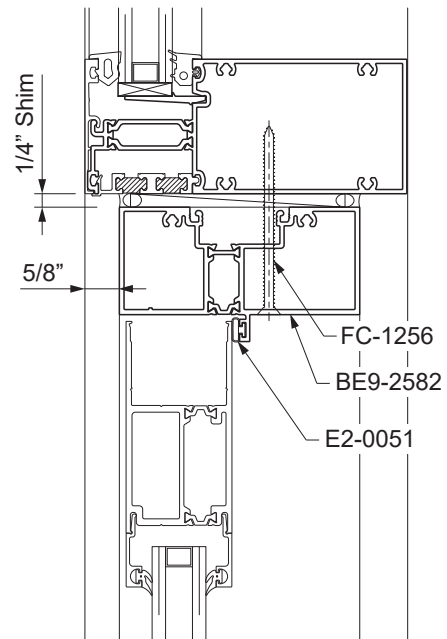

Detail 100

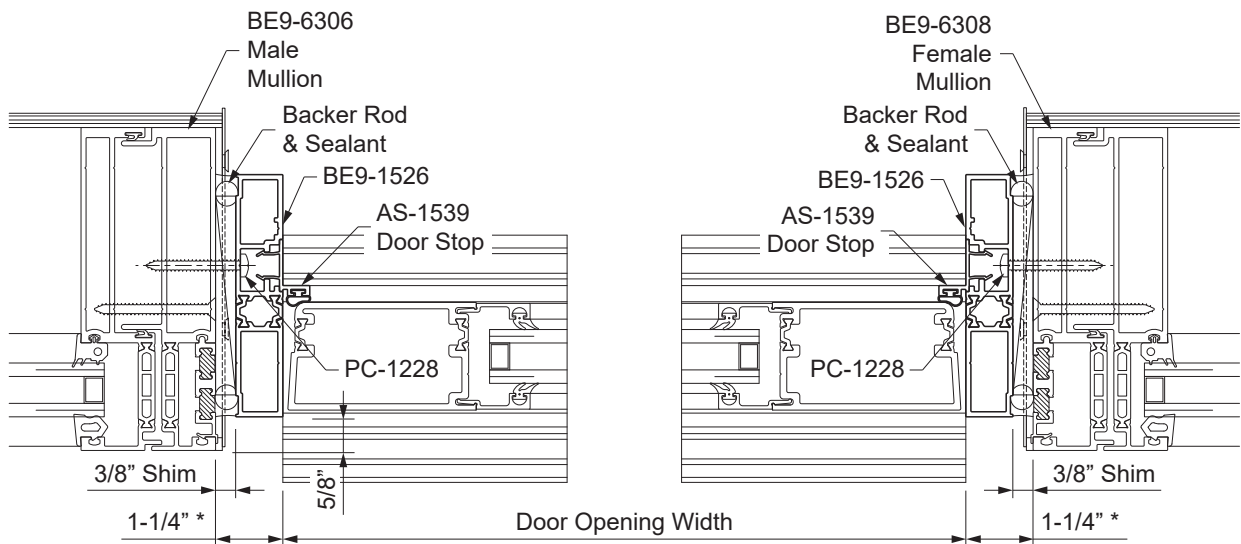

Detail 101

DOOR FRAME INSTALLATION

STEP 36
GLAZE DOOR TRANSOM

See Details 102 & 103.

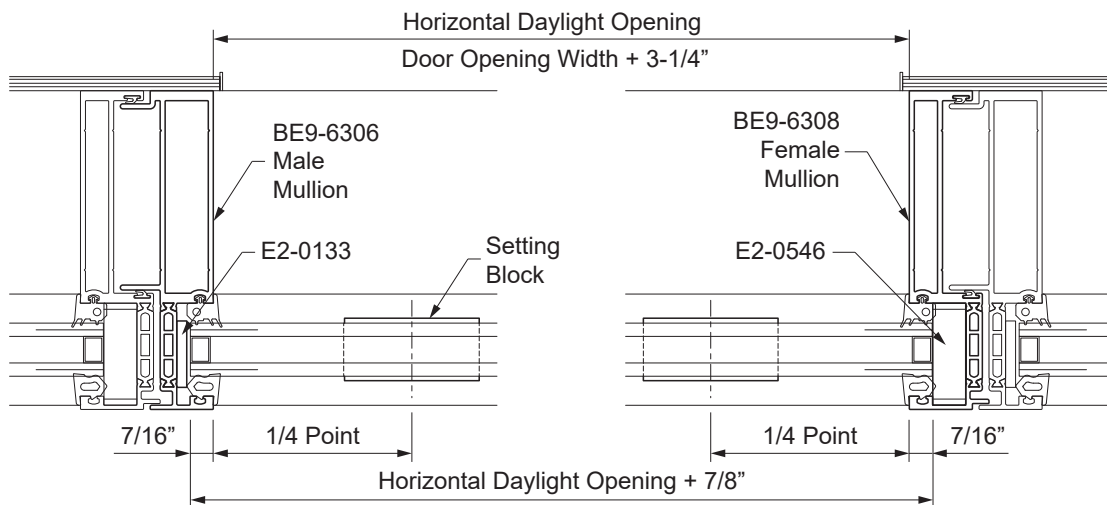
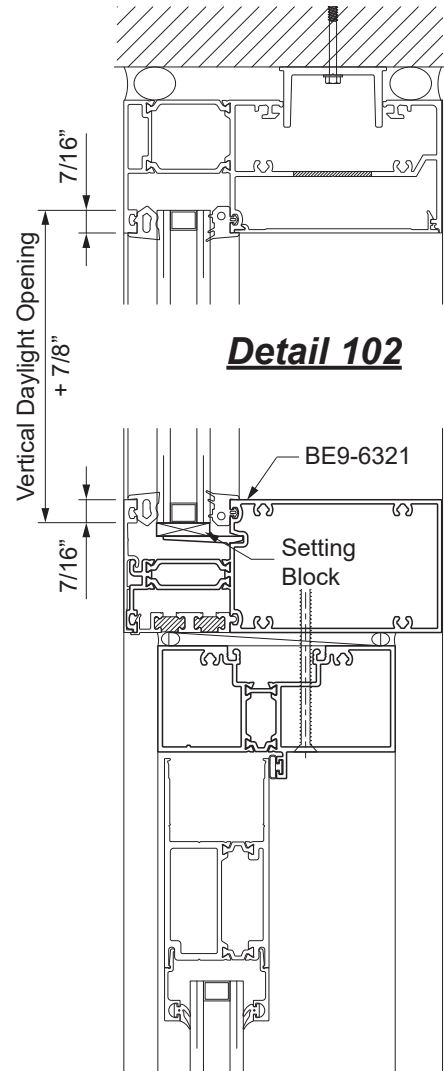

Detail 103

 **YKK AP America Inc.**

101 Marietta Street NW

Suite 2100

Atlanta, Georgia 30303

www.ykkap.com