

**YCW 750 SplineTech® Curtain Wall System**

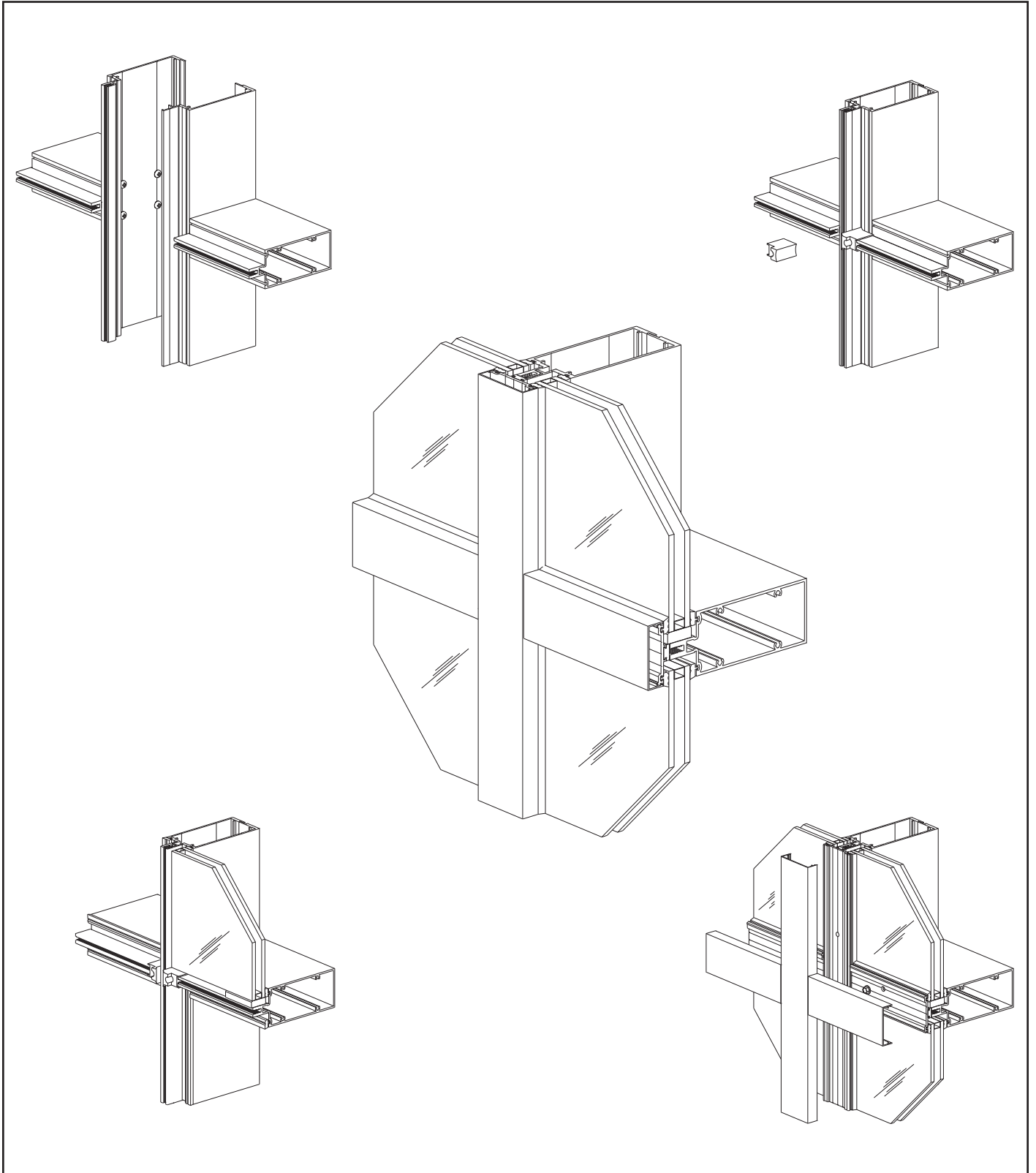

**Installation Manual**



## TABLE OF CONTENTS

Installation Notes .....	Page ii
<b>PARTS DESCRIPTION</b>	
YCW 750 SplineTech Framing Members.....	Pages 1 & 2
YCW 750 SplineTech Accessories.....	Pages 2 to 4
<b>FRAME FABRICATION</b>	
General Notes .....	Page 5
Fabricate Vertical Mullions .....	Pages 6 to 8
Fabricate Horizontal Members .....	Pages 9 & 10
Fabricate Pressure Plates .....	Page 11
Fabricate Face Covers .....	Page 12
<b>FRAME ASSEMBLY</b>	
Assembling Ladders in the Shop.....	Page 13
Completion of Ladder Assemblies.....	Page 13
Install Joint Plugs.....	Page 14
Install Glazing Adaptors.....	Page 15
Using Alternate Reinforcing.....	Page 16
Install Interior Gaskets.....	Page 17
<b>FRAME INSTALLATION</b>	
Typical Vertical Splice .....	Pages 18 & 19
Jamb/Vertical Installation With Mullion End Anchors.....	Page 20
Install/Remove Vertical Mullion Clips.....	Page 21
Installation of Optional Incidental Water Head .....	Page 22
General Notes on Ladder Installation .....	Page 23
Ladder Anchoring Method .....	Pages 24 & 25
Install Wind Load/Dead Load Anchors.....	Pages 26 to 28
Jamb Installation with Jamb Anchors.....	Page 29
Apply Perimeter Sealant.....	Page 30
Install Door Subframes .....	Page 31
<b>GLAZING</b>	
Install Setting & Side Blocks .....	Page 32
Install Exterior Glazing Gaskets .....	Page 33
Install Glass .....	Page 33
Install Vertical Pressure Plate .....	Page 34
Pressure Plate Layout and Assembly .....	Page 35
Install Exterior Face Covers .....	Pages 36 & 37











## Installation Notes

1. Do not drop, roll or drag boxes of aluminum framing. Move and stack boxes with proper support to prevent distortion. If fork lifts are used be especially careful about striking the boxes when lifting or moving.
2. Store in a dry, out of the way area. If rain exposure, condensation or any water contact is likely, then all packaging material should be removed. Wet packaging materials will discolor and may stain aluminum finishes and paints.
3. All materials should be checked for quality and quantity upon receipt, YKK AP must be notified immediately of any discrepancies in shipment. Check to make sure that you have the required shims, sealants, supplies and tools necessary for the installation.
4. Carefully check the openings and surrounding conditions that will receive your material. Remember, if the construction is not per the construction documents, it is your responsibility to notify the general contractor in writing. Any discrepancies must be brought to the general contractor's attention before you proceed with the installation.
5. Gather your shop drawings, materials, packing list, and this installation manual. Carefully review parts, location, the sequence it goes therein, when you glaze it, and how you seal it. Installation instructions are of a general nature and may not cover every condition you will encounter. The shop drawings and/or installation manuals were prepared specifically for the product.
6. Any material substitutions must be of equal or greater quality.
7. Make certain that material samples have been sent for compatibility testing for all manufacturer's sealants involved. Make certain sealants have been installed in strict accordance with the manufacturer's recommendations and specifications.
8. Remember to isolate, in an approved manner, all aluminum from uncured masonry or other incompatible materials.
9. System-to-structure fasteners are not supplied by YKK AP. Fasteners called out on shop drawings are to indicate minimum sizes for design loading.
10. If any questions arise concerning YKK AP products or their installation, contact YKK AP for clarification before proceeding.
11. YKK AP storefront and/or curtain wall framing is typically completed before drywall, flooring and other products which may still be in process. Take the extra time to wrap and protect the work produced.
12. Cutting tolerances are plus zero, minus one thirty second unless otherwise noted.
13. Check our website, [www.ykkap.com](http://www.ykkap.com), for the latest installation manual update prior to commencing work.

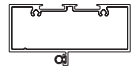





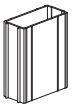

FRAMING MEMBERS

	<b>Horizontal</b> 2-1/2" x 5-1/4" For 1/4" Glazing	<b>E9-3610</b>		<b>Horizontal</b> 2-1/2" x 5-1/4" For 1" Glazing	<b>E9-3605</b>
	<b>Horizontal</b> 2-1/2" x 3-3/4" For 1/4" Glazing	<b>E9-3630</b>		<b>Horizontal</b> 2-1/2" x 3-3/4" For 1" Glazing	<b>E9-3625</b>
	<b>Female Mullion Half</b> 2-1/2" x 5-1/4" For 1/4" Glazing	<b>E9-3607</b>		<b>Female Mullion Half</b> 2-1/2" x 5-1/4" For 1" Glazing	<b>E9-3602</b>
	<b>Male Mullion Half</b> 2-1/2" x 5-1/4" For 1/4" Glazing	<b>E9-3606</b>		<b>Male Mullion Half</b> 2-1/2" x 5-1/4" For 1" Glazing	<b>E9-3601</b>
	<b>Female Mullion Half</b> 2-1/2" x 3-3/4" For 1/4" Glazing	<b>E9-3627</b>		<b>Female Mullion Half</b> 2-1/2" x 3-3/4" For 1" Glazing	<b>E9-3622</b>
	<b>Male Mullion Half</b> 2-1/2" x 3-3/4" For 1/4" Glazing	<b>E9-3626</b>		<b>Male Mullion Half</b> 2-1/2" x 3-3/4" For 1" Glazing	<b>E9-3621</b>
	<b>Jamb</b> Open Back 2-1/2" x 5-1/4" For 1/4" Glazing	<b>E9-3588</b>		<b>Jamb</b> Open Back 2-1/2" x 5-1/4" For 1" Glazing	<b>E9-3580</b>
	<b>Jamb</b> Open Back 2-1/2" x 3-3/4" For 1/4" Glazing	<b>E9-3592</b>		<b>Jamb</b> Open Back 2-1/2" x 3-3/4" For 1" Glazing	<b>E9-3584</b>
	<b>Head/Sill</b> Open Back/Incidental Water 2-1/2" x 5-1/4" For 1/4" Glazing	<b>E9-3609</b>		<b>Head/Sill</b> Open Back/Incidental Water 2-1/2" x 5-1/4" For 1" Glazing	<b>E9-3604</b>
	<b>Head/Sill</b> Open Back/Incidental Water 2-1/2" x 3-3/4" For 1/4" Glazing	<b>E9-3629</b>		<b>Head/Sill</b> Open Back/Incidental Water 2-1/2" x 3-3/4" For 1" Glazing	<b>E9-3624</b>
	<b>Horizontal Flush Filler</b> 2-1/2" x 5-1/4" For 1/4" & 1" Glazing	<b>E9-3162</b>		<b>Standard Pressure Plate</b> E9-1216 with PVC Isolator Punched 9" O.C.	<b>AS-1216</b>
	<b>Horizontal Flush Filler</b> 2-1/2" x 3-3/4" For 1/4" & 1" Glazing	<b>E9-3595</b>	(Optional) 	<b>Pressure Plate</b> For Deep Covers E9-3574 with PVC Isolator Punched 9" O.C.	<b>AS-3574</b>

## FRAMING MEMBERS

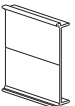



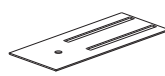







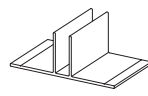

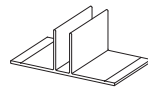

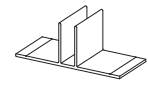

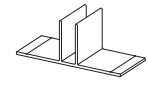

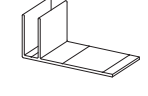

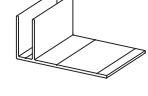
	<b>Infill Adaptor</b> For 1/4" Glazing	<b>E9-3620</b>		<b>Face Cover</b> 2-1/2" x 1-1/2"	<b>E9-3521</b>
	<b>Standard Face Cover</b> 2-1/2" x 3/4"	<b>E9-1206</b>		<b>Bull Nose Face Cover</b> 2" x 2-1/2"	<b>E9-1293</b>
	<b>Face Cover</b> 2-1/2" x 1-3/4", Use with AS-3574 Pressure Plate	<b>E9-1229</b>		<b>Single Acting Transom Bar</b> Elastomer Weathering E2-0051 Included	<b>AS-0402</b>
	<b>Face Cover</b> 2-1/2" x 2-3/8", Use with AS-3574 Pressure Plate	<b>E9-1219</b>		<b>Door Jamb</b> For 1/4" Glazing Use with AS-0417	<b>E9-1224</b>
	<b>Horizontal Face Cover</b> 11/16" x 2-1/2"	<b>E9-1207</b>		<b>Door Jamb</b> For 1" Glazing Use with AS-0417	<b>E9-3513</b>
	<b>Face Cover</b> 2-1/2" x 1-1/8"	<b>E9-3504</b>		<b>Snap-In Door Stop</b> Elastomer Weathering E2-0051 Included Use with E9-1224	<b>AS-0417</b>

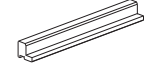
## ACCESSORIES

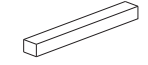
	<b>Mullion Joint Sleeve</b> For 5-1/4" Depth Members	<b>E1-1201</b>		<b>Mullion Clip</b> For 3-3/4" Depth Two Piece Vertical	<b>E1-3562</b>
	<b>Jamb Splice Sleeve</b> For 3-3/4" Depth Members	<b>E1-1354</b>		<b>Splice Sleeve</b> <b>For 3/4" Face Cover</b> For E9-1206 Face Cover	<b>E1-1202</b>
	<b>Splice Sleeve</b> For 5-1/4" Depth Two Piece Vertical	<b>E1-3561</b>		<b>Splice Sleeve For</b> <b>1-3/4" &amp; 2" Face Cover</b> For E9-1229 and E9-1291 Face Cover	<b>E1-1203</b>
	<b>Splice Sleeve</b> For 3-3/4" Depth Two Piece Vertical	<b>E1-3563</b>		<b>Standard Mullion End Cap</b> 2-1/2" x 2-1/4" x 0.050"	<b>E1-1286</b>
	<b>Mullion Clip</b> For 5-1/4" Depth Two Piece Vertical	<b>E1-3560</b>		<b>Mullion End Cap</b> For 3-3/4" Depth Optional Incidental Water Head	<b>E1-3527</b>

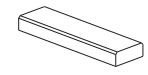

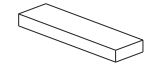
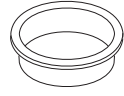
\*Anchor attachment will vary depending on job conditions. Consult YKK AP or qualified engineer.

## ACCESSORIES





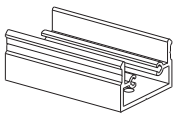

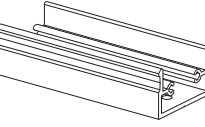
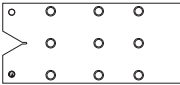

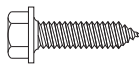

	<b>Mullion End Cap</b> For 5-1/4" Depth Optional Incidental Water Head	<b>E1-3526</b>		<b>Standard Joint Plug</b> For 1" Glazing	<b>E2-0102</b>
	<b>Intermediate Vertical "T" End Anchor*</b> For 5-1/4" Depth Members E9-3601 & E9-3602	<b>E1-1222</b>		<b>Optional Jamb Anchor Clip*</b> For For 3-3/4" Back Depth Use with E9-3584 & E9-3592	<b>E1-3524</b>
	<b>Intermediate Vertical "T" End Anchor*</b> For 5-1/4" Depth Members E9-3606 & E9-3607	<b>E-1242</b>		<b>Optional Jamb Anchor Clip*</b> For For 5-1/4" Back Depth Use with E9-3580 & E9-3588	<b>E1-3525</b>
	<b>Intermediate Vertical "T" End Anchor*</b> For 3-3/4" Depth Members E9-3621 & E9-3622	<b>E1-1229</b>		<b>Temporary Glass Retainer</b> 2" Long	<b>E1-1294</b>
	<b>Intermediate Vertical "T" End Anchor*</b> For 3-3/4" Depth Members E9-3626 & E9-3627	<b>E1-1226</b>		<b>Nylon Slip Pad</b> For Wind Load and Dead Load Anchor	<b>E3-0103</b>
	<b>Jamb "F" Anchor</b> For 3-3/4" Depth Members	<b>E1-1232</b>		<b>Wind Load Anchor*</b> Refer to Shop Drawings for Anchor Dimensions	<b>E1-1204</b>
	<b>Jamb "F" Anchor</b> For 5-1/4" Depth Members	<b>E1-1231</b>		<b>Dead Load Anchor*</b> Refer to Shop Drawings for Anchor Dimensions	<b>E1-1205</b>
	<b>Setting Block</b> With Pressure Sensitive Adhesive For 1/4" Glazing	<b>E2-0112</b>		<b>Jamb Anchor Plate</b>	<b>E1-3536</b>
	<b>Side Block</b> With Pressure Sensitive Adhesive For 1/4" Glazing	<b>E2-0113</b>		<b>Weep Baffle</b> Use with Incidental Water Head Members	<b>E2-0099</b>
	<b>Setting Block</b> For 1" Glazing	<b>E2-0104</b>		<b>1-1/2" Incidental Water Plug</b> Use with Incidental Water Head Members	<b>E3-1166</b>
	<b>Side Block</b> For 1" Glazing	<b>E2-0105</b>		<b>1-1/8" Incidental Water Plug</b> Use with Incidental Water Head Members	<b>E3-1167</b>
	<b>Standard Joint Plug</b> For 1/4" Glazing	<b>E2-0125</b>		<b>Interior/Exterior Glazing Gasket</b>	<b>E2-0120</b>

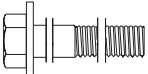
\*Anchor attachment will vary depending on job conditions. Consult YKK AP or qualified engineer.

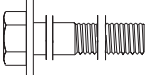
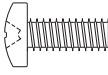
## ACCESSORIES

 <p><b>Steel Reinforcing</b> For 5-1/4" Back Depth Two Piece Mullion</p>	<p><b>E1-0183</b></p>	 <p><b>Door Jamb Anchor</b> Use With: E9-3621 &amp; E9-3622 E9-3626 &amp; E9-3627 E9-3631 &amp; E9-3632</p>	<p><b>E1-3565</b></p>
 <p><b>Steel Reinforcing</b> For 3-3/4" Back Depth Two Piece Mullion</p>	<p><b>E1-9988</b></p>	 <p><b>Door Jamb Anchor</b> Use With: E9-3601 &amp; E9-3602 E9-3606 &amp; E9-3607 E9-3611 &amp; E9-3612</p>	<p><b>E1-3564</b></p>
 <p><b>Drill Fixture</b></p>	<p><b>H-7211</b></p>		

## FASTENERS

 <p><b>#8 x 1/2" PHSMS</b> <b>Type F</b> Stainless Steel, For Attachment of Splice Sleeve Face Covers</p>	<p><b>PF-0808</b> <b>-SS</b></p>	 <p><b>1/4"-20 x 1" HWHMS</b> Stainless Steel For Attachment of Pressure Plate to Mullion</p>	<p><b>HD-2516</b> <b>-W3-SS</b></p>
 <p><b>#10 x 3/8" PHSMS</b> <b>Type AB</b>, Zinc Plated Steel, For Attaching Mullion Halves Together at Side of Tongue</p>	<p><b>PC-1006</b></p>	 <p><b>1/2"-13 x 2" HWHMS</b> Zinc Plated Steel, For Attachment of Windload/ Deadload Anchor at Jamb</p>	<p><b>HM-5032</b></p>
 <p><b>#12 x 1-1/4" PHSMS</b> <b>Type AB</b>, Zinc Plated Steel, For Screw Spline Attachment</p>	<p><b>PC-1220</b></p>	 <p><b>1/2"-13 x 4-1/2" HWHMS</b> Zinc Plated Steel, For Attachment of Windload/ Deadload Anchor at Mullion</p>	<p><b>HM-5072</b></p>
 <p><b>1/4"-20 x 5/8" PHMS</b> Zinc Plated Steel For Temporary Engagement of Mullion Halves</p>	<p><b>PM-2510</b></p>	 <p><b>1/2"-13 Nut HHMS</b> Zinc Plated Steel For Attachment of Mid-Anchors (Wind Load / Dead Load)</p>	<p><b>HM-5000</b></p>
 <p><b>#12 x 3/4" FHSMS</b> <b>Type AB</b>, Zinc Plated Steel, For Attachment of Vertical Mullions to Splice</p>	<p><b>FC-1212</b></p>	 <p><b>1/2" Flat Washer</b> Zinc Plated Steel, For Attachment of Mid-Anchors (Wind Load / Dead Load)</p>	<p><b>WW-5000</b></p>
 <p><b>1/4" x 5/8" FHSMS</b> <b>Type AB</b>, Zinc Plated Steel, For Attachment of Mullion End Cap</p>	<p><b>FC-1410</b></p>	 <p><b>1/2" Lock Washer</b> Zinc Plated Steel, For Attachment of Mid-Anchors (Wind Load / Dead Load)</p>	<p><b>WS-5000</b></p>



## FRAME FABRICATION

### GENERAL NOTES:

These drawings and instructions are written so that the glazier will be installing ladder assemblies from right to left. If the installer chooses to go from the left to the right, mullion halves should be reversed, or 'mirrored', as shown in these drawings.

### FRAME TYPES / ANCHORING METHODS

The following is a guideline for common types of frames. Refer to shop drawings for exact layout of frames.

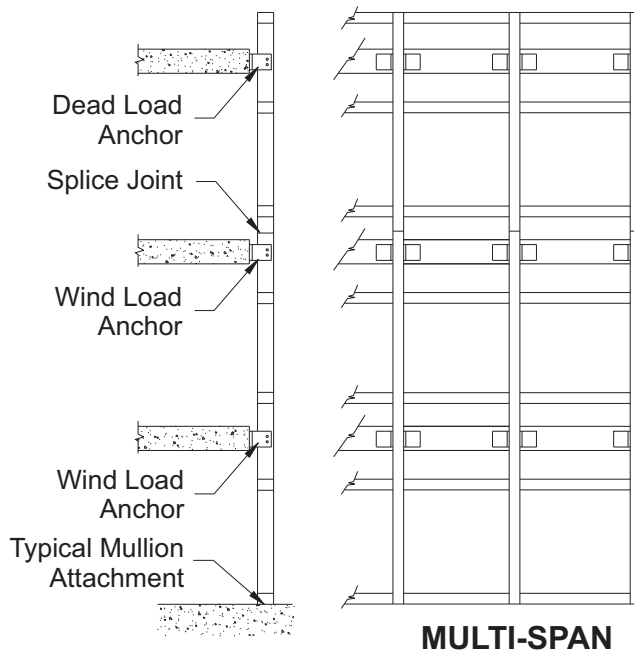
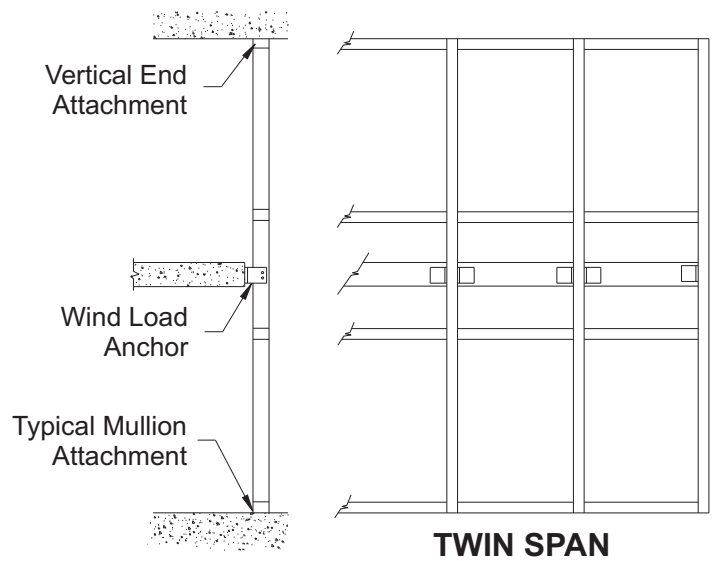
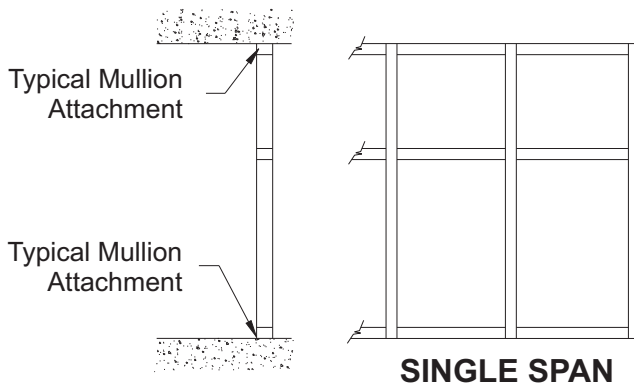

Shop fabricated and pre-assembled ladders can be installed in the field.

**Note:** If YKK AP does not prepare the shop drawings for the project, a qualified engineer must approve all anchors, their arrangement, and mullion selection.

All anchors must be attached to structurally sound material that will accommodate the anchor reactions.

## FRAME FABRICATION

### STEP 1 VERTICAL MULLION FABRICATION OPTIONS

Fabrication of verticals may be:

- Hand fabrication, see dimensions below.
- Drill fixture fabrication, see **Step 2**.
- Punch dies, contact YKK AP sales representative.
- Mullion hole locations for horizontal members are shown below.
- Drill 0.238" dia. (# B drill bit) holes for screw splines at the locations indicated.

See **Detail 1**.

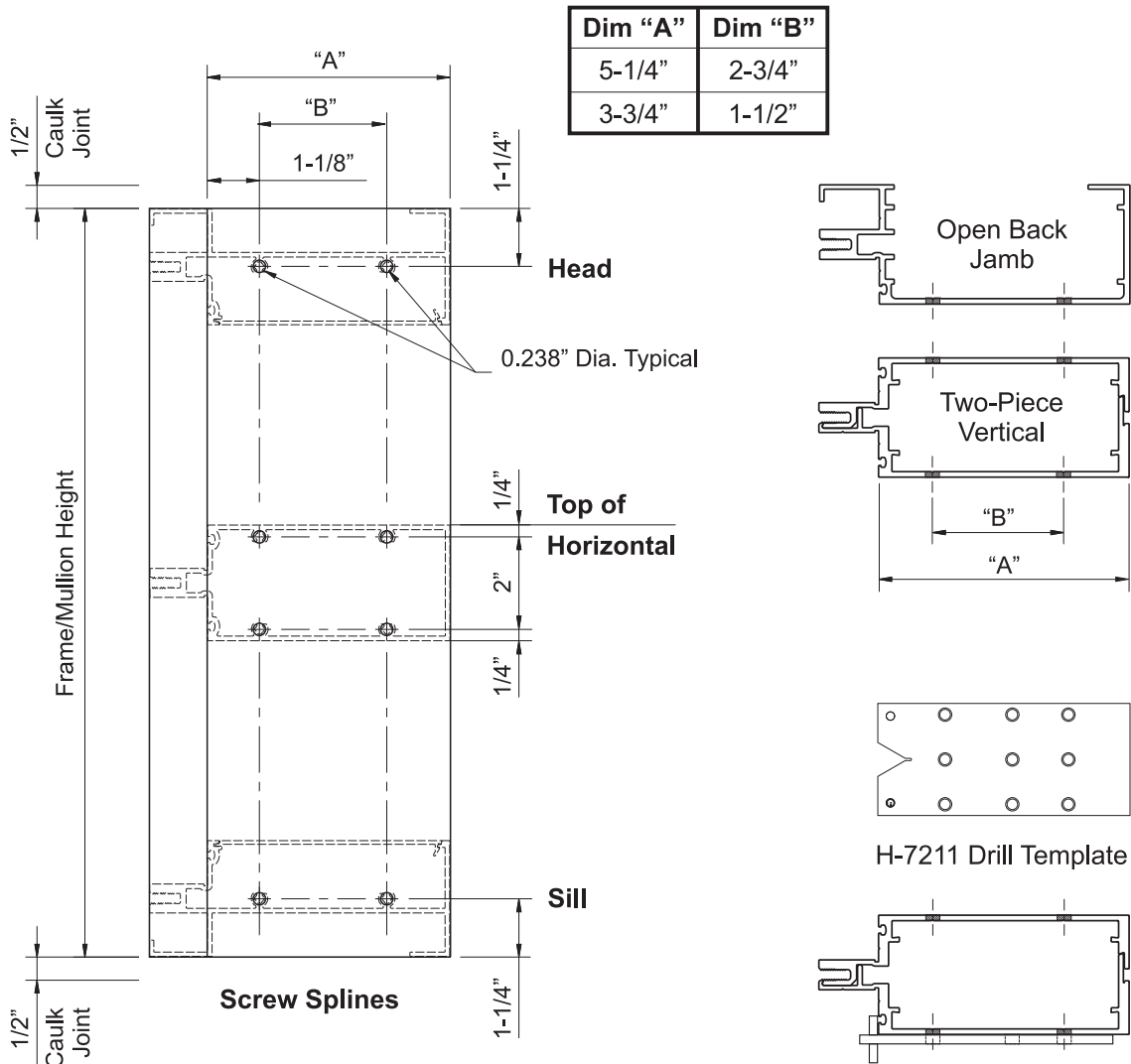

**Detail 1**

FRAME FABRICATION

STEP 1 (Continued)  
DOOR JAMB MULLION FABRICATION OPTIONS

Mullions at door jambs are sealed against the substrate at the sill without a shim space at that location.

See **Detail 2**.

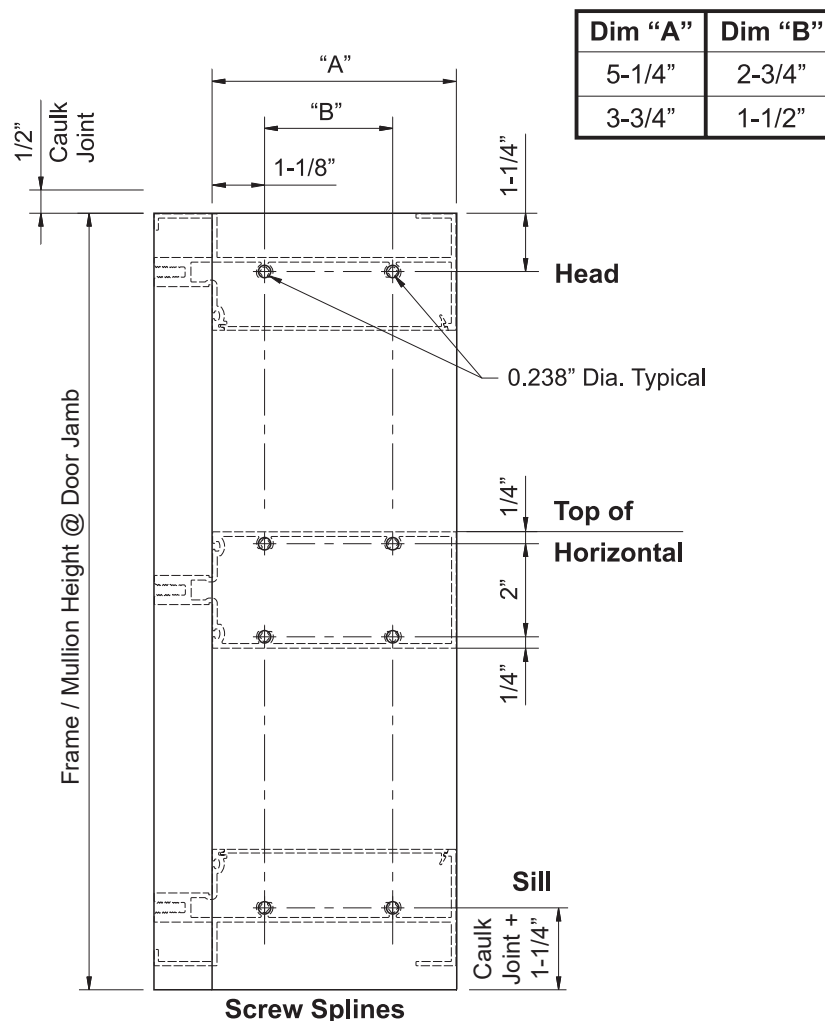

**Detail 2**

**FRAME FABRICATION****STEP 2  
FABRICATE VERTICAL MULLIONS**

- Locate horizontal center lines on male and female mullion halves.
- Male and female mullion halves can be placed as shown for ease of clamping together.
- Clamp drill fixture H-7211 stationary with a squeeze clamp and drill 0.238" (#B drill bit) clear holes as required.

See **Detail 3**.

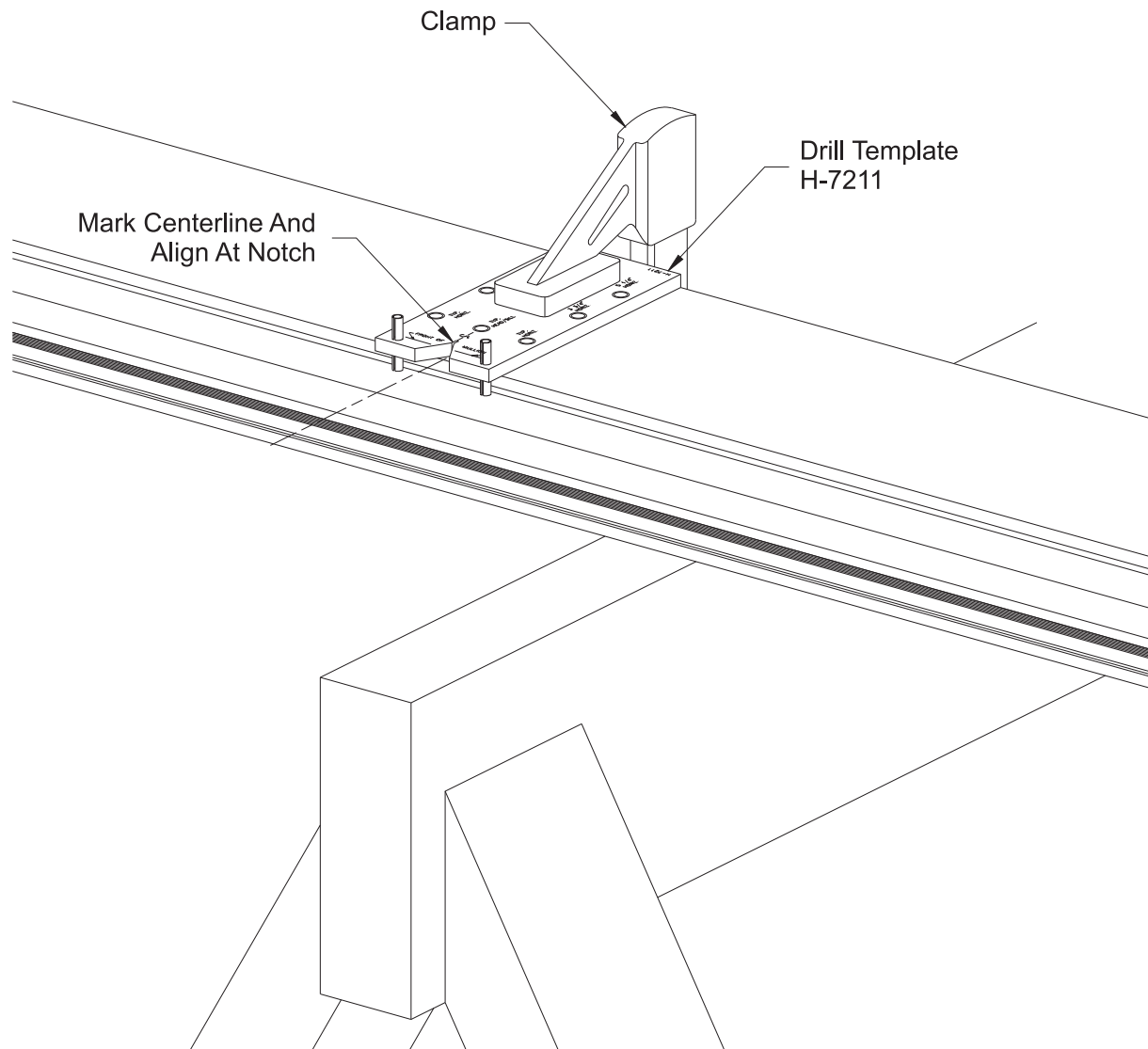

**Detail 3**

## FRAME FABRICATION

### STEP 3 FABRICATE HORIZONTAL MEMBERS

-Cut all horizontal members to the daylight opening as shown in shop drawings.

See **Detail 4**.

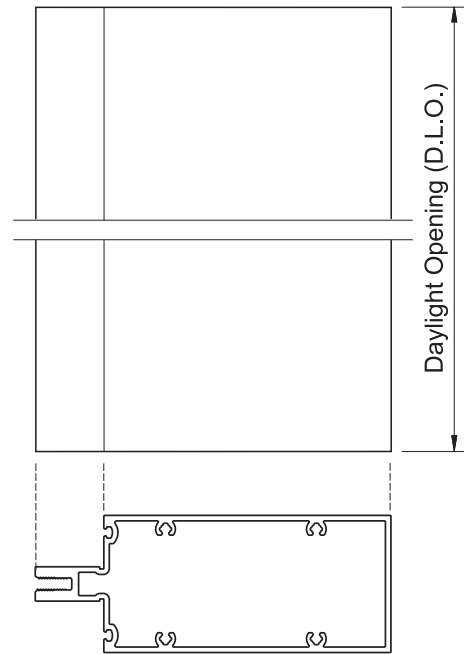

**Detail 4**

### Head and Sill Horizontals:

-Cut all head and sill horizontal members to the daylight opening as shown in shop drawings.  
-Cut all horizontal flush fillers to the daylight opening minus (-)1/32".

See **Detail 5**.

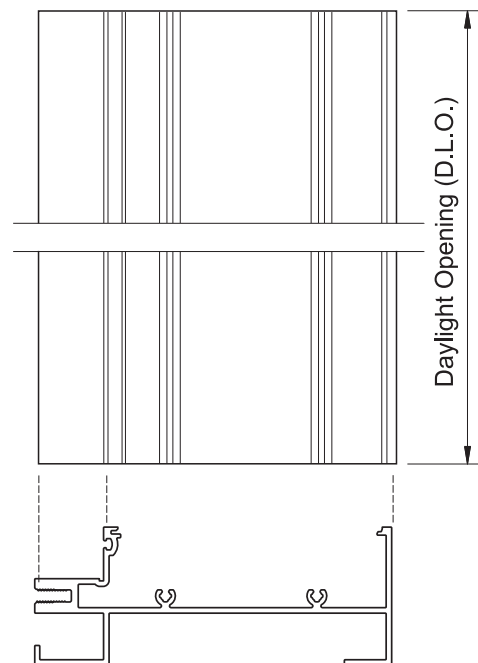

**Detail 5**

**FRAME FABRICATION**

**STEP 3 (Cont'd)  
FABRICATE HORIZONTAL MEMBER**

**Head and Sill Horizontals:**

Head and sill horizontal members require drilling clear holes to permit access to the “F” and “T” anchors that will secure the frame to the structure.

- Drill clear holes for “F” or “T” anchors as shown.
- Drill 1-1/8” holes for 3/8” anchors.
- Drill 1-1/2” holes for 1/2” anchors.

See **Detail 6**.

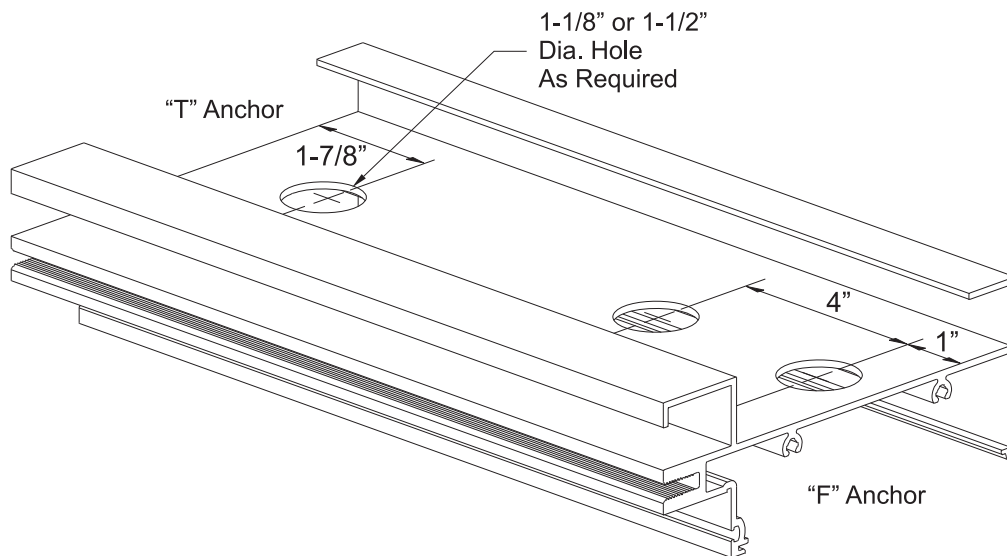

**Detail 6**

FRAME FABRICATION

**STEP 4**  
**FABRICATE PRESSURE PLATES**

**Horizontal Pressure Plates:**

- Cut horizontal pressure plates to the daylight opening between verticals minus(-) 1/4".
- Pressure plate stock lengths have 0.281" dia. holes factory drilled every 9" on center. After cutting, drill additional holes 1-1/2" from each end.
- Drill two 0.313" (5/16") diameter weep holes 3" from each end and one at the centerline of the pressure plate.

See **Detail 7**.

**Note:** If the space between the weep holes exceeds 3', additional weep holes should be drilled to ensure that there is no more than 3' between the weep holes.

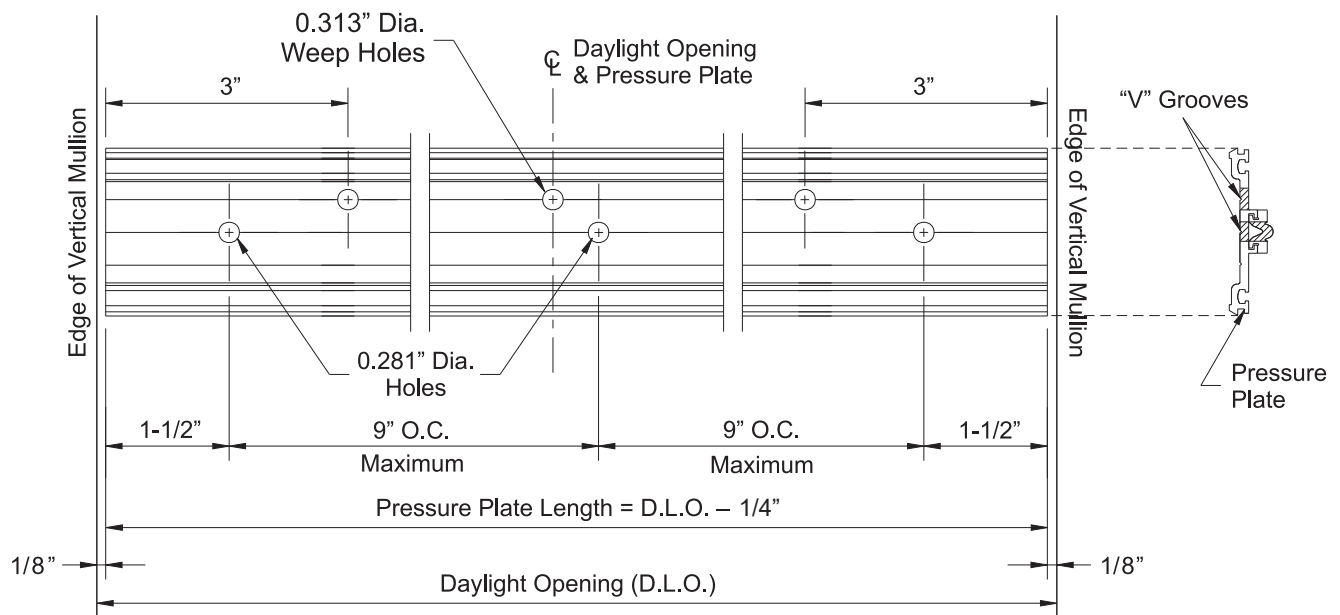

**Detail 7**

**Vertical Pressure Plates:**

- Cut vertical and jamb pressure plates to the same length as the vertical mullions.
- If vertical mullions are spliced, cut pressure plates to accommodate for 1/2" expansion joint as shown in **Step 11** on **Pages 18 & 19**.
- Drill additional attachment holes if required to ensure that end holes are at 1-1/2" from each end.

## FRAME FABRICATION

### STEP 5 FABRICATE FACE COVERS

#### Horizontal Face Covers:

- Cut horizontal face covers to the daylight opening between verticals minus(-) 1/16".
- Drill two 0.313" diameter weep holes at 1/3 points of cover as shown below.

See **Detail 8**.

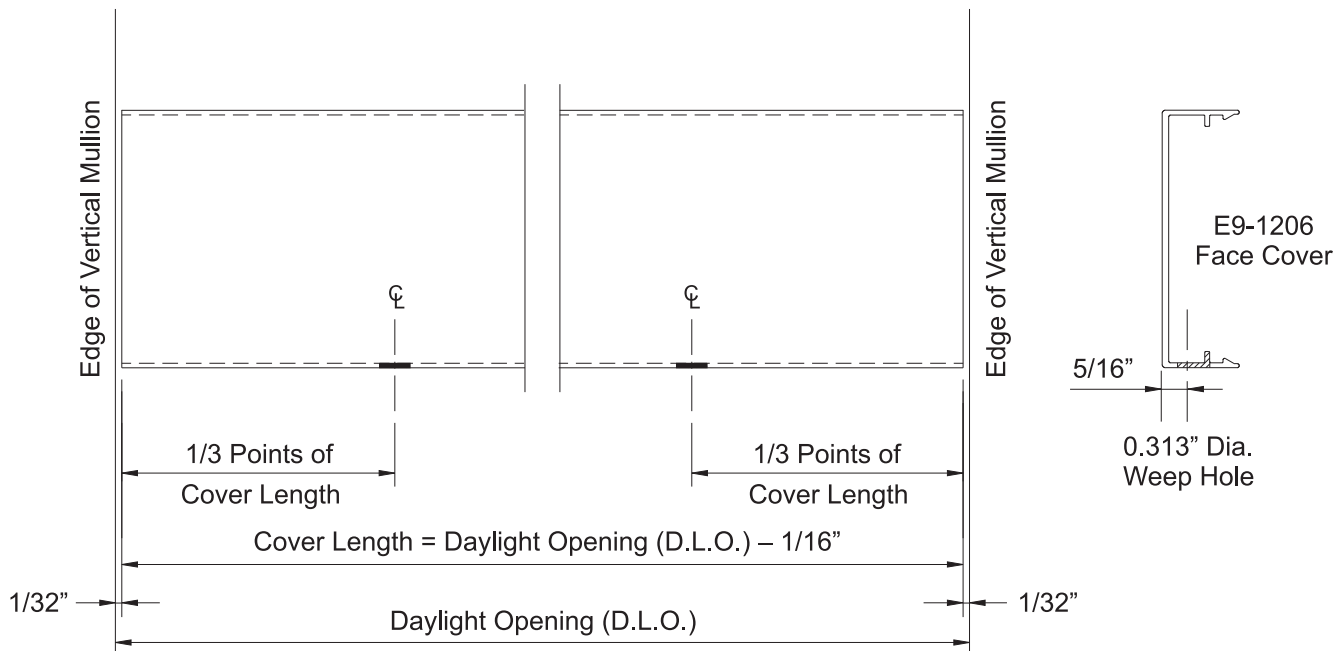

**Detail 8**

#### Vertical Face Covers:

- Cut vertical face covers to the same length as the vertical mullions unless the verticals are spliced.
- If vertical mullions are spliced, cut vertical covers to accommodate for the 1/2" expansion joint as shown in **Step 11** on **Pages 18 & 19**.



## FRAME ASSEMBLY

### STEP 6 ASSEMBLING LADDERS IN THE SHOP

- Place vertical mullion halves in proper position on sawhorses.
- Mark as left or right half, head and sill respectively.
- Apply sealant to both ends of all horizontal members immediately prior to assembly to provide additional water tightness. Tool and clean off any excess sealant.
- Assemble vertical mullion halves to head, sill, and intermediate horizontals with #12 x 1-1/4" PHSMS Type AB (PC-1220) Spline Screws.
  - 4 each per head/sill
  - 8 each per intermediate horizontal

Fabrication Tip: Do not tighten screws completely until all members are in place.

See **Detail 9**.

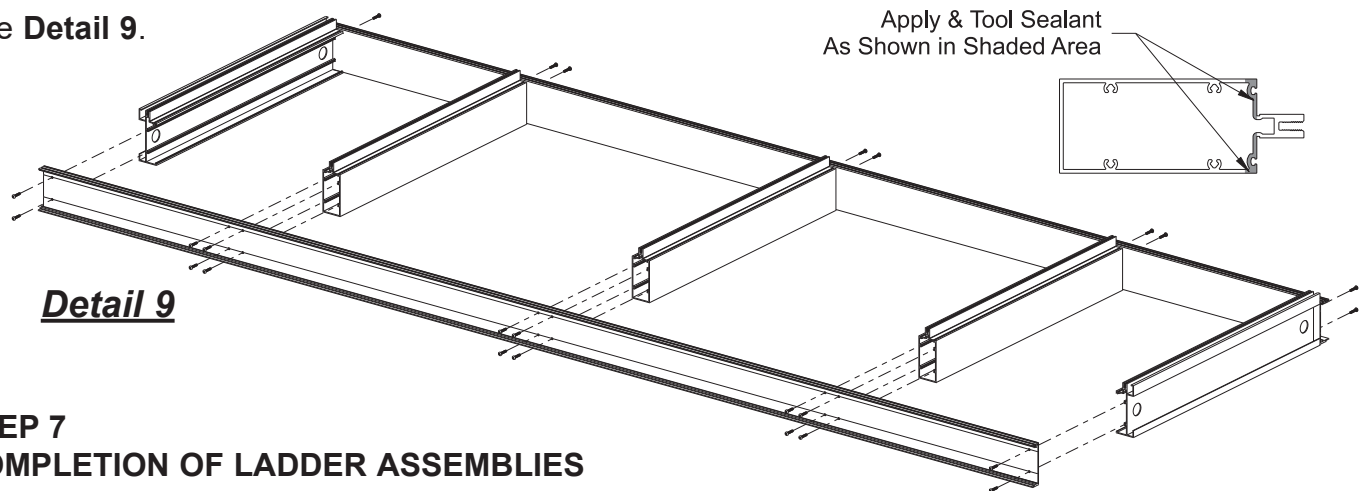

### STEP 7 COMPLETION OF LADDER ASSEMBLIES

-After ladders are assembled, end caps, joint seals, joint plugs and interior gaskets may be installed in house prior to shipping ladders to the job site.

**Note:** Assemblies must be kept clean and away from objects that may pull or distort the gaskets, critical seals or finish.

See **Detail 10**.

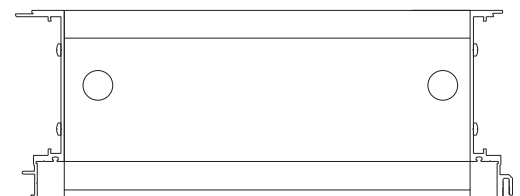
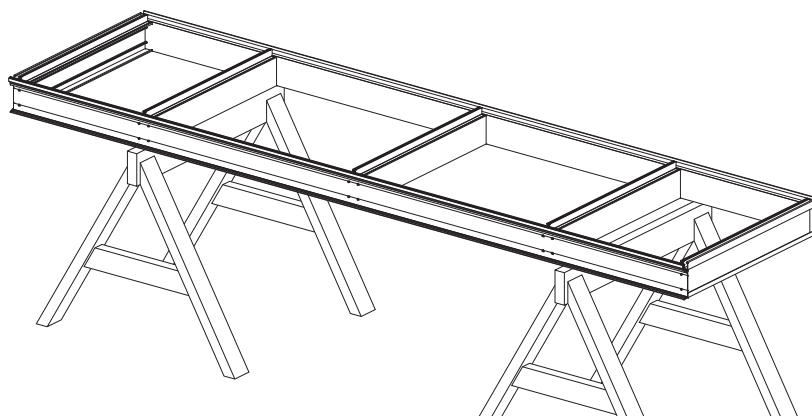

Ladder Assembly

**Detail 10**

## FRAME ASSEMBLY

### STEP 7 (Cont'd) INSTALL JOINT PLUGS

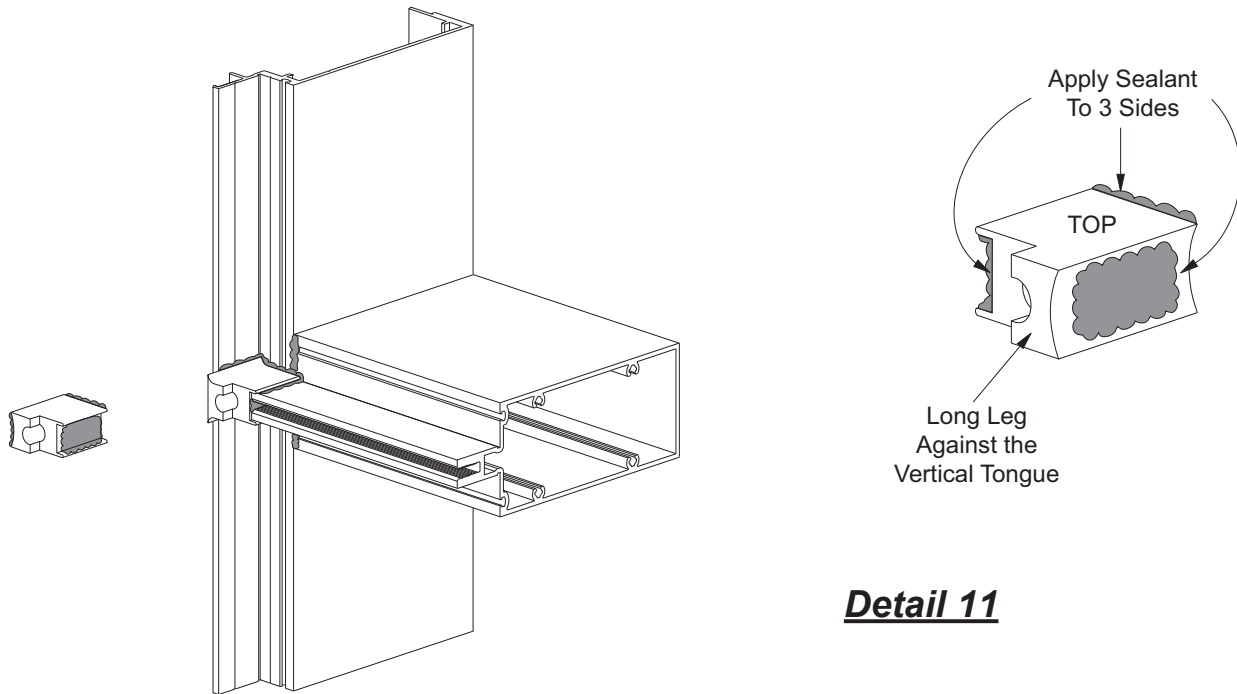

**Detail 11**

The tongue of each horizontal must be sealed to the tongue of the vertical mullions. The space between the two tongues is closed by using joint plugs, E2-0102 for 1" glazing or E2-0125 for 1/4" glazing.

- Clean the area around the tongue intersection with an approved cleaner.
- Apply and tool sealant to the intersection of the horizontal and vertical.
- Apply sealant to the three contact sides of the joint plug and at the intersection of the vertical and horizontal glazing pocket.
- Install joint plug as shown with the long leg of plug against the vertical tongue.
- Press joint plugs firmly against face of mullion.
- Tool the sealant to ensure a watertight seal.
- Seal all exposed screw heads on the face of the mullion.

See **Detail 11**.

FRAME ASSEMBLY

**STEP 8**  
**INSTALL GLAZING ADAPTORS**  
**(When Required)**

**Note:** 1/4" glazing adaptor, E9-3620 shown.

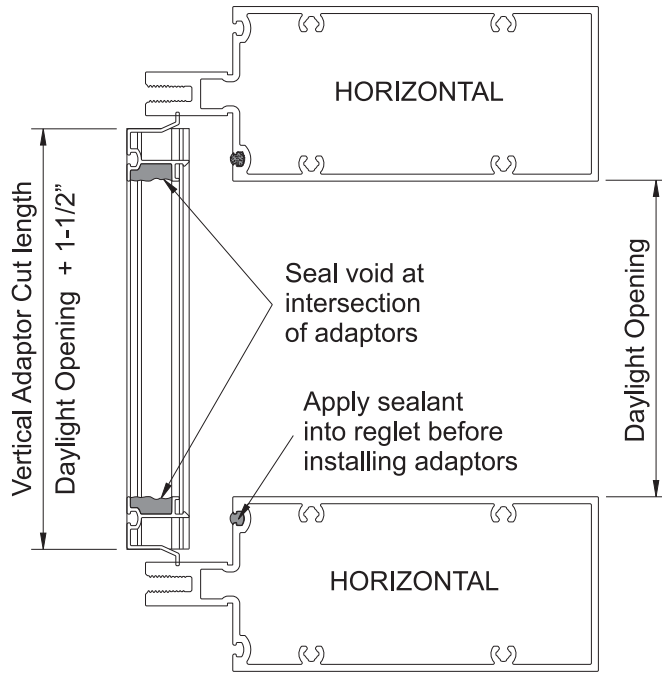

**Detail 12**

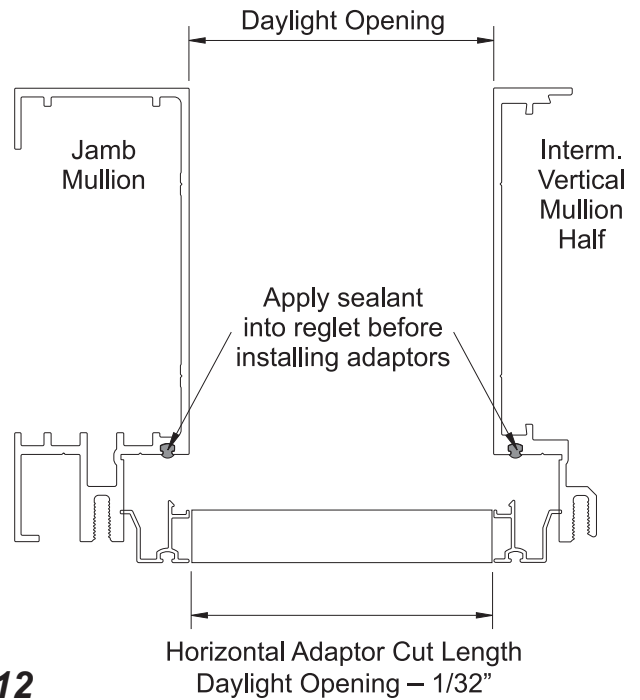

-Cut glazing adaptors to size:

Vertical Cut Length = Daylight Opening plus(+) 1-1/2".

Horizontal Cut Length = Daylight Opening minus(-) 1/32".

-Vertical adaptors must be installed before horizontal adaptors.

-Clean the area around the mullion glazing reglet and the glazing adaptor with a cleaner approved by the sealant manufacturer.

-Apply sealant into the glazing reglet of the mullion .

-Install the vertical adaptors first, centered along the day light opening.

-Fill void at all adaptor intersections with sealant, tool as needed.

See **Detail 12**.

-Snap adaptors in place using a mallet and wood block, to prevent damage.

See **Detail 13**.

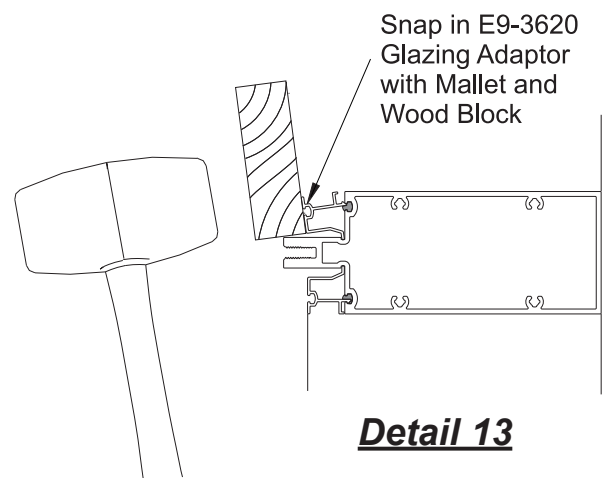

**Detail 13**

**FRAME ASSEMBLY**

**STEP 9  
USING ALTERNATE REINFORCING**

When engineering calculations require the vertical mullions to be reinforced with steel, secure the reinforcing to the vertical using the appropriate fasteners per engineering calculations.

- Allow 3" at top and bottom of vertical mullion for "F" and "T" anchors.
- Fasten steel reinforcement E1-0183, 1" from the top and bottom end of the steel, and max. 36" O.C. with a flat head fastener as shown.
- Seal all screw heads with silicone sealant.

**Note:** The exact size and location of steel reinforcing and fasteners to be determined by a qualified engineer.  
Steel reinforcing **must** be spliced for spans greater than 10'.

See **Detail 14**.

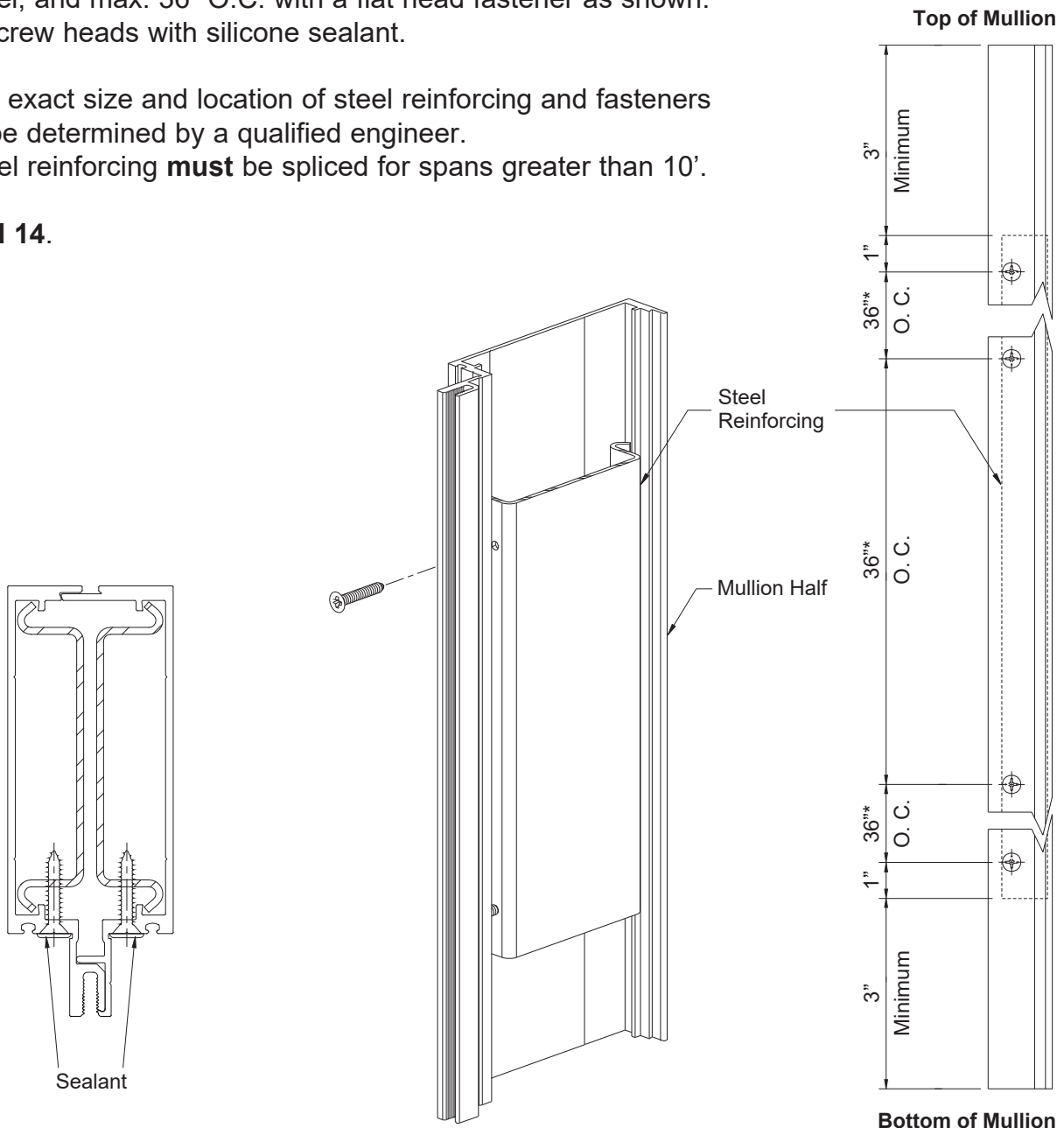

**Detail 14**

## FRAME ASSEMBLY

### STEP 10 INSTALL INTERIOR GLAZING GASKETS

- Cut interior glazing gaskets to size:
  - Vertical Gasket = Daylight Opening + 1-1/2".
  - Horizontal Gasket = Daylight Opening + 1/4" per each foot of opening width.
- Install vertical gaskets first, centered along the daylight opening.
- Install horizontal gaskets next.
  - Insert the gaskets into the reglet at each end first.
  - Insert the rest of the gasket into the reglet starting at the center and work towards each end.

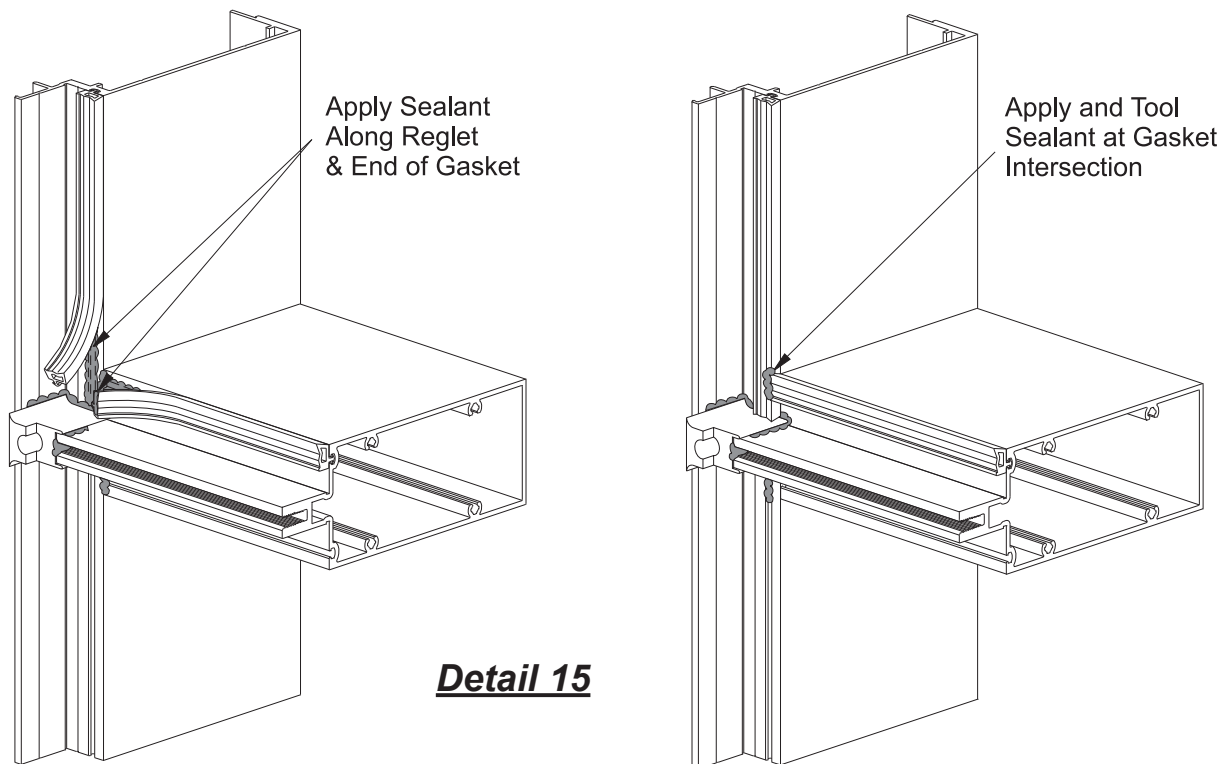

- Pull the last 3" of each gasket away from the reglet.
- With gasket end held out of the way, run a 2-3" bead of sealant into the reglet at the ends.
- Apply sealant at the ends of the horizontal gaskets.
- Reinsert the ends of the gaskets pressing them firmly against the face of the mullions.
- Apply and tool sealant at the intersection of the vertical and horizontal gaskets.

See **Detail 15**.

**FRAME INSTALLATION**

**STEP 11  
TYPICAL VERTICAL SPLICE**

Stagger Mullion, Pressure Plate, and Cover Splice Joints as Shown Below.

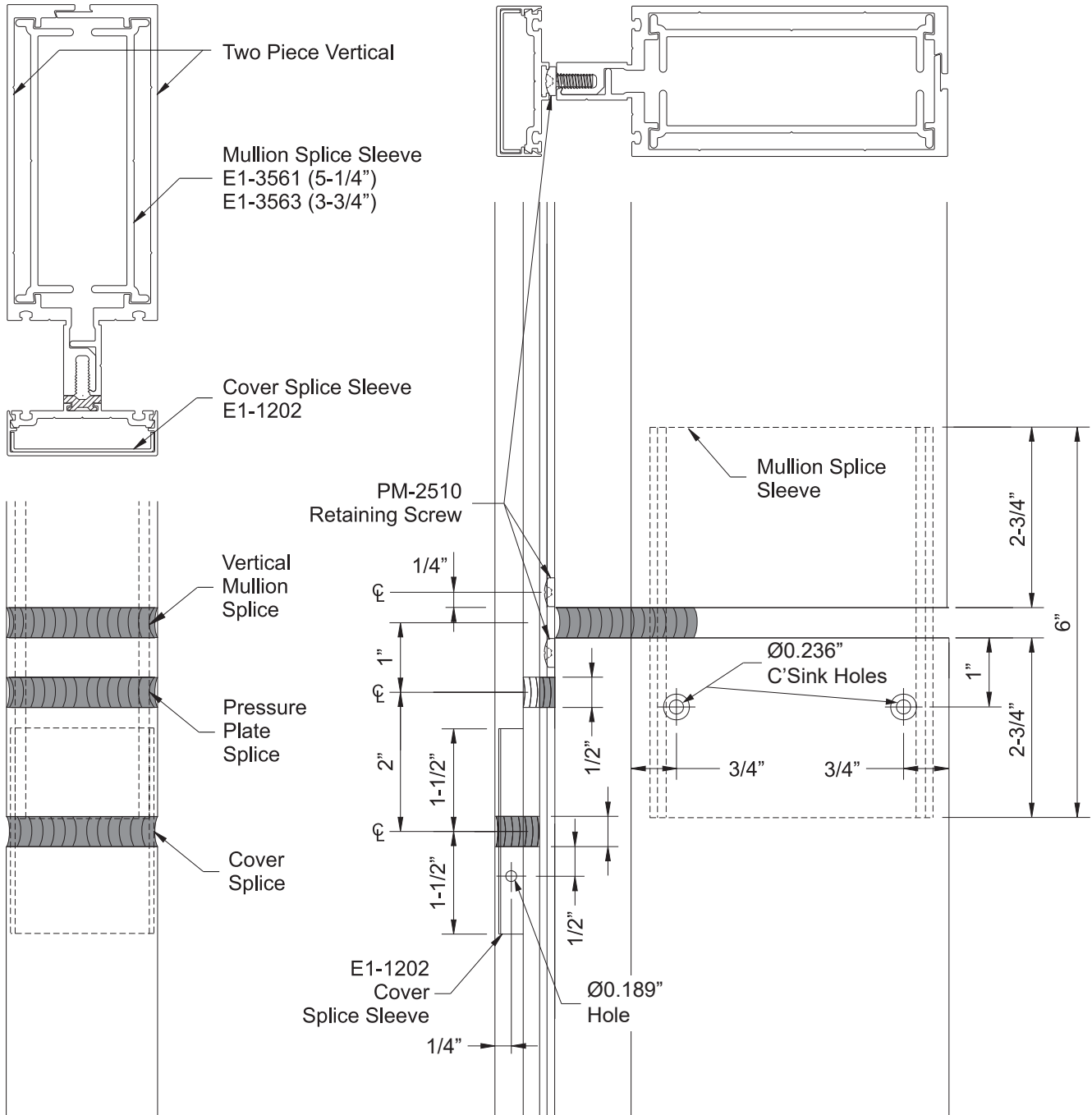

***Detail 16***

FRAME INSTALLATION

STEP 11 (Continued)  
TYPICAL VERTICAL SPLICE

- Clean all surfaces as recommended by sealant manufacturer.
- At 3/4" from the front and back of the lower mullion and down 1" from the top, drill Ø0.236" (#B drill bit) holes, and countersink for #12 flat head fasteners, on each side of the mullion.
- Apply bond breaker tape to the face of the splice sleeve at its midpoint (3" from top or bottom).
- Lower the splice sleeve into top of lower mullion 2-3/4" and attach with two FC-1212 fasteners on both sides of the mullion.
- When using 1" glazing mullions, stuff a small piece of backer rod 1/2" down the cavity behind mullion tongue and pump in sealant to fill the cavity in both the top and bottom members.
- Apply sealant to the face of splice sleeve on the upper half and carefully slide the upper mullion down onto the splice sleeve. Place a 1/2" temporary shim between the mullions to locate them.
- Secure the upper mullion to the mid anchors and remove the temporary shims.
- Apply and tool sealant to the face and sides of the splice sleeve to create a water tight joint.

-Leave a 1/2" expansion joint between vertical pressure plate splices and fill the joint with sealant.

- Locate pressure plate fasteners 1-1/2" from each end of pressure plate splice as shown.
- Apply bond breaker tape to the face of the cover splice sleeve and attach it to the lower face cover with a PF-0808-SS fastener on each side.
- Prior to snapping on the upper portion of the face cover, apply sealant to the face of the splice.
- Leave a 1/2" expansion joint between face cover splices.

See **Detail 17**.

**Note:** Face covers, pressure plates, and mullions are staggered at splice locations, retaining screws should be used at top and bottom of verticals. Cut thermal isolator 1-1/2" from bottom of top pressure plate.

See **Detail 16, Page 18**.

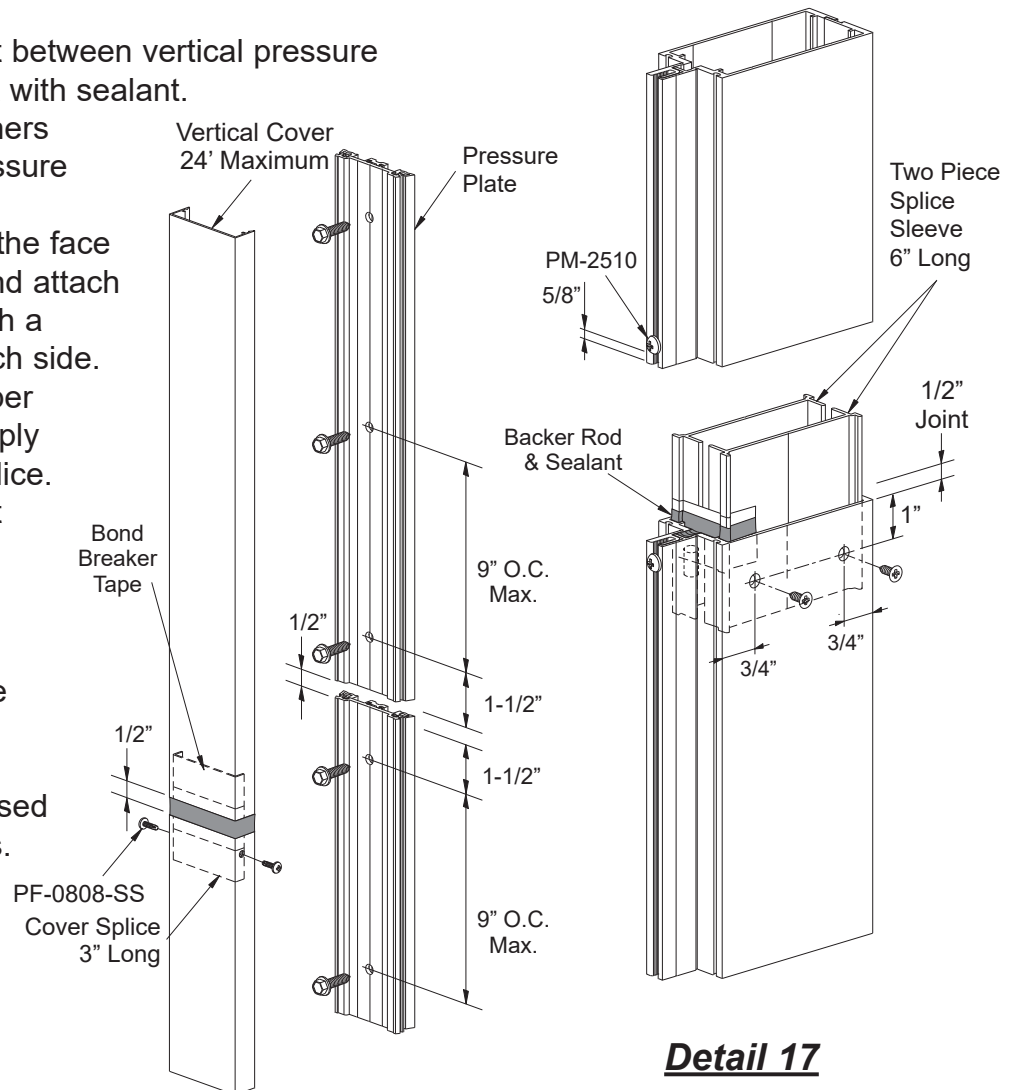

**Detail 17**

**FRAME INSTALLATION**

**STEP 12  
JAMB/VERTICAL INSTALLATION  
WITH MULLION END ANCHORS**

- Prior to erecting ladders, install mullion end caps, E1-1286, at the top and bottom of the mullions with FC-1410 fasteners.
- Clean all contact surfaces as recommended by sealant manufacturer.
- Apply sealant to ends of verticals prior to installing end cap E1-1286.
- Apply sealant into the screw raceway and along the front edge of the mullion at each end.
- Seal all screw heads with sealant.

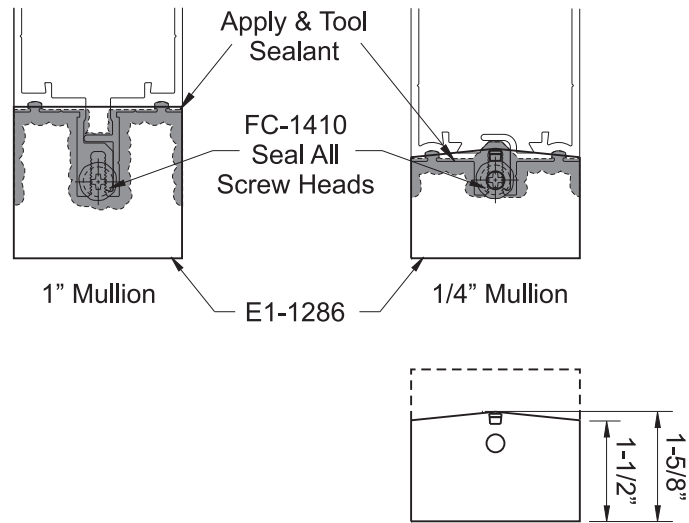

Trim As Shown

**Detail 18**

- Tape mullion “T” and “F” anchors into the top and bottom of the mullions before erecting them into the opening. “T” anchors can also be added after unit half is erected.
- Erect and locate the first ladder assembly and temporarily attach it to the structure. All mullions must be installed plumb and true.
- Field drill holes in “F” and “T” anchors for the appropriate anchor fasteners according to shop drawings or engineering calculations. Consult YKK AP if load requirements are in question.

See **Detail 19**.

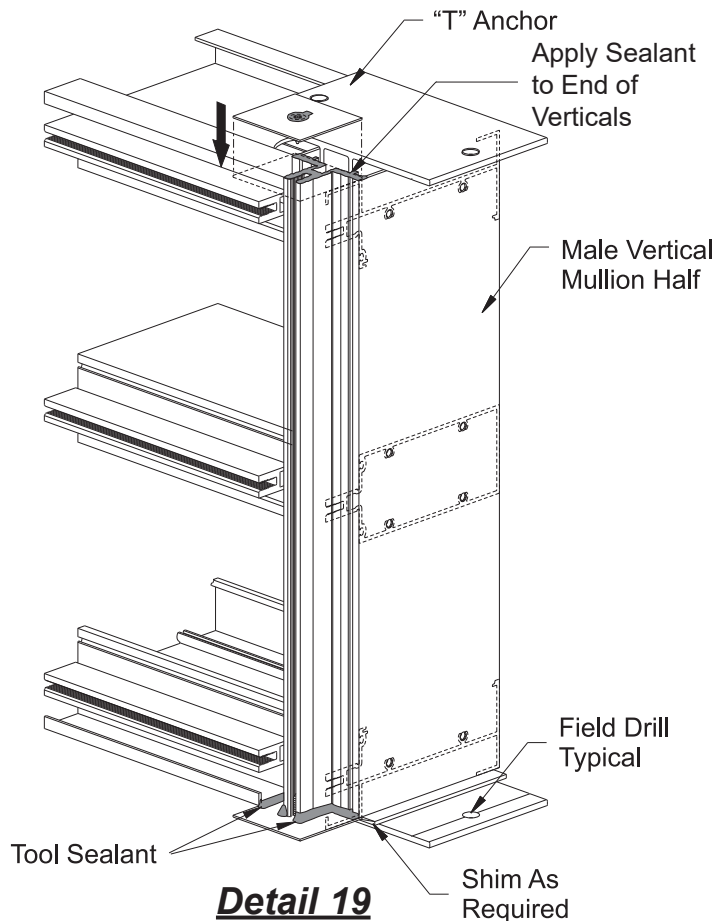

**Detail 19**



## FRAME INSTALLATION

### STEP 13 INSTALL VERTICAL MULLION CLIPS

Mullion clips are required to prevent the back side of the mullion from separating under high load conditions. Clips are not required where an intermediate horizontal is located. Refer to approved shop drawings for mullion clip locations.

-Mark both halves of vertical as shown below in order to locate mullion clip should removal be necessary. A small dot of silicone sealant placed at the front center of the clip prior to installation will prevent the clip from sliding down inside the mullion under extreme load conditions.

See **Detail 20**.

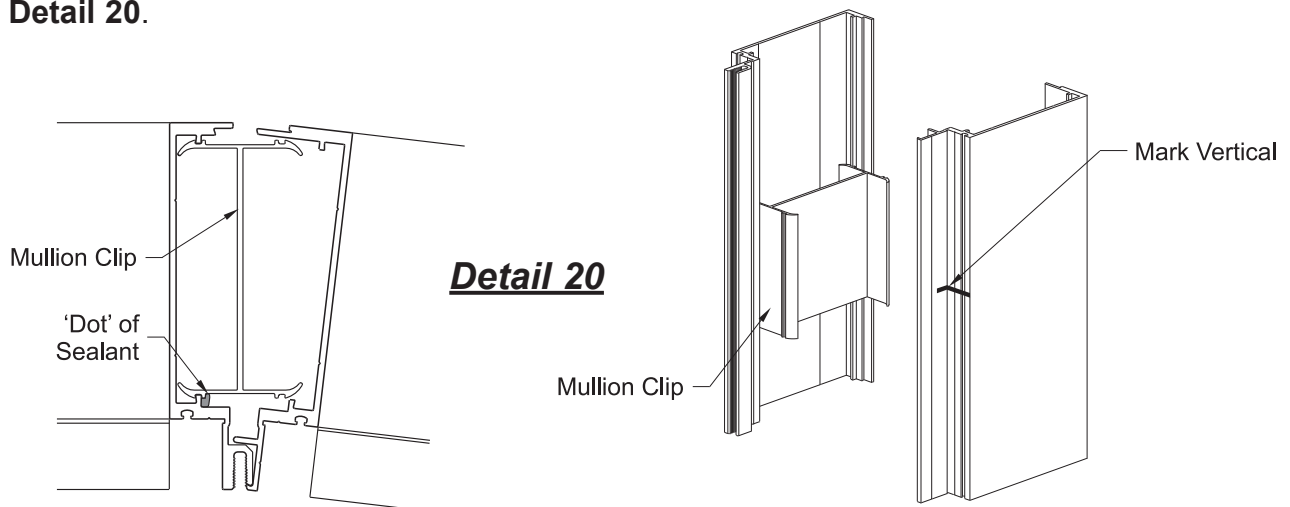

### REMOVAL OF VERTICAL MULLION CLIPS

In the event a ladder assembly should need to be separated, the mullion clips will need to be removed, discarded and replaced. Under no circumstances should mullion clips be re-used.

- Locate mullion clips at marks as indicated above.
- Drill 0.25" holes at 'V' groove on both halves of vertical mullion.
- Insert screwdriver blade into holes and tap end of screwdriver with mallet until mullion clip bends and slides down in mullion.
- Seal holes with silicone when finished.

See **Detail 21**.

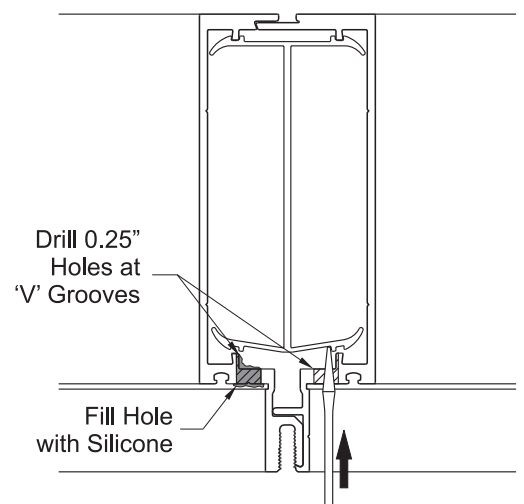

**Detail 21**

**FRAME INSTALLATION**

**STEP 14  
INSTALLATION OF OPTIONAL  
INCIDENTAL WATER HEAD**

- Prior to ladder assembly installation, seal horizontal to vertical as shown in **Detail 22**.
- Locate 0.313" weep holes at 1/3 points of incidental water head member.
- Install a weep baffle, E2-0099, directly behind each weep hole. Dab a small amount of sealant on the bottom of the weep baffle to secure it.
- Install mullion end cap E1-3526 onto female mullion half.
- Slide anchor into mullion half, then install ladder assembly as described previously.
- To plug the anchor access holes, apply sealant on the underside surface around the perimeter of the clear hole prior to installing E3-1166 plug.
- Apply and tool sealant completely over and around the plug after inserting and seating it in place.
- Snap on the mullion flush filler.

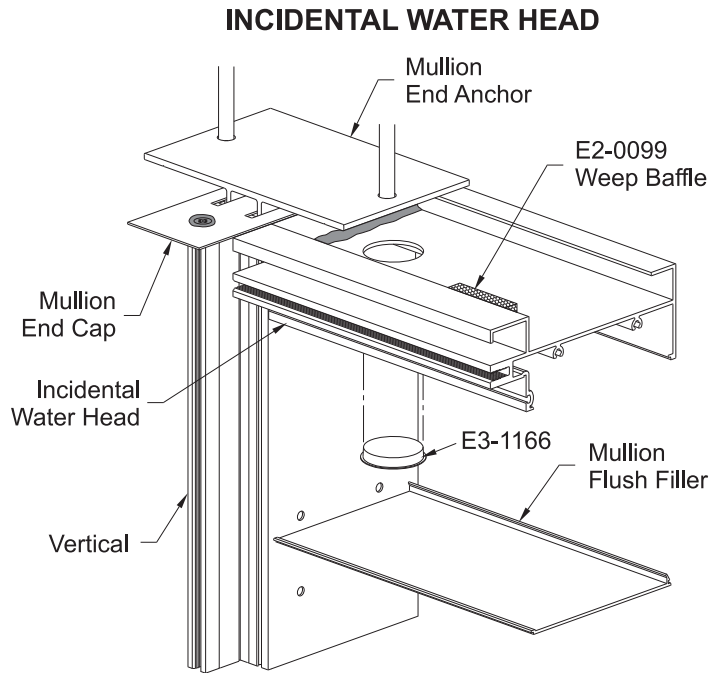

**Detail 21**

See **Details 21(A) & 22**.

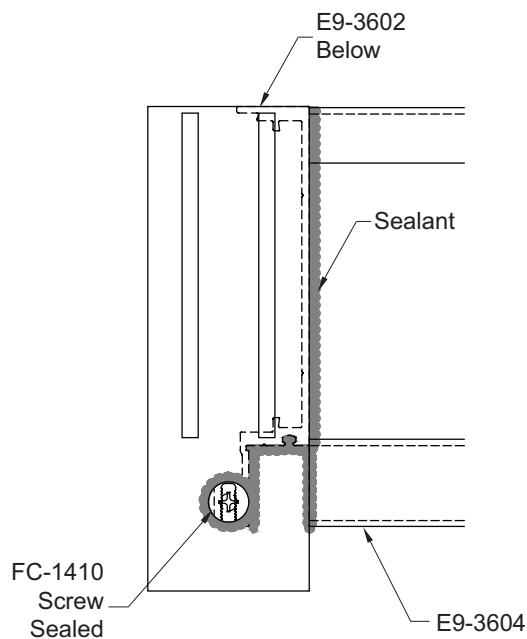

**Detail 21A**

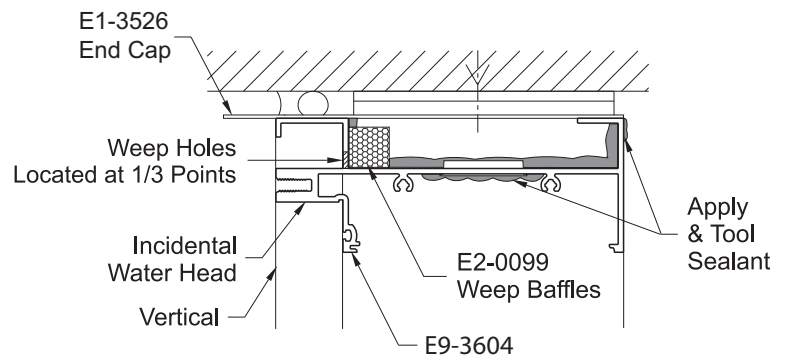

**Detail 22**

FRAME FABRICATION

STEP 15

GENERAL NOTES:

Typical Ladder Installation

Ladder Assemblies, or units, are typically rotated into place, starting right to left with the engagement at the front tongue. Holding the front of the mullion halves together at the tongue, rotate the new ladder assembly into the receiving unit until the mullion halves engage. On shorter installations, the units may be installed from the side, eliminating the need for rotation. On odd shape elevations, such as spokes, splays, etc., YKK AP’s shear block version, YCW 750 OG may be required. YCW 750 OG may be easily integrated into the YCW 750 OSS Screw Spline mullion assembly.

Installation of Final Ladder Assembly

When installing the final ladder assembly, rotate the final unit as described above. Units with a daylight opening of 42” or less may not rotate into an opening with a 1/2” or less perimeter caulk joint. In order to install such an assembly, the configuration illustrated below is recommended. Attach the final two ladders together and work the assembly into the opening as one final unit. Rotating a larger assembly will allow the back of the jamb mullion to clear the masonry opening.

See **Details 23**.

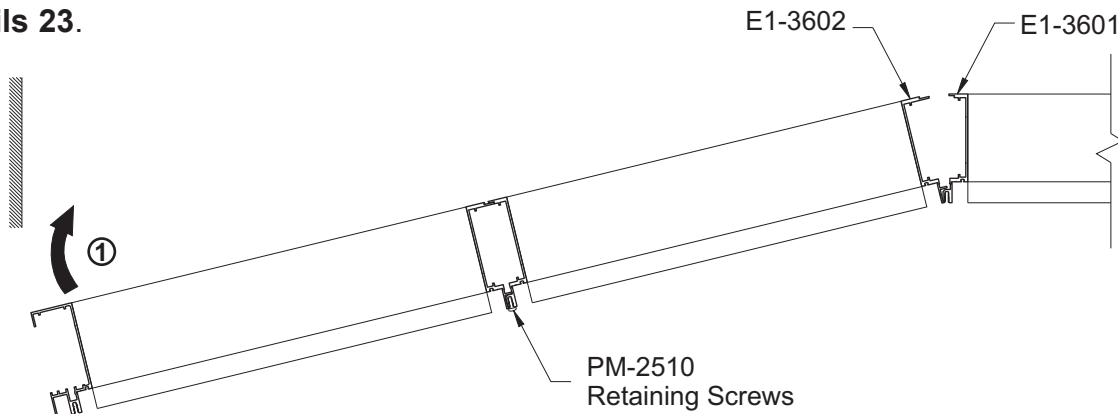

OPTIONAL ROTATION OF TWO FINAL LADDER ASSEMBLIES

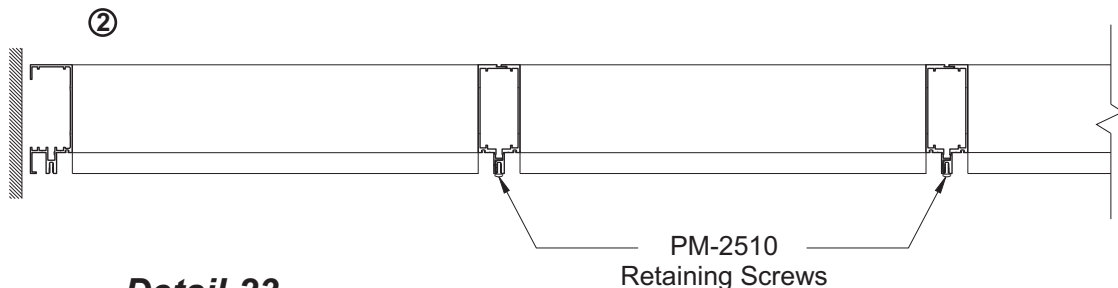

**Detail 23**

COMPLETED INSTALLATION

**STEP 15 (Continued)**  
**LADDER ANCHORING METHOD****Ladder Preparation**

-Just prior to erection of assembled ladders, apply sealant to the top and bottom of every mullion half as shown in **Detail 24**. This includes at the splice joints.

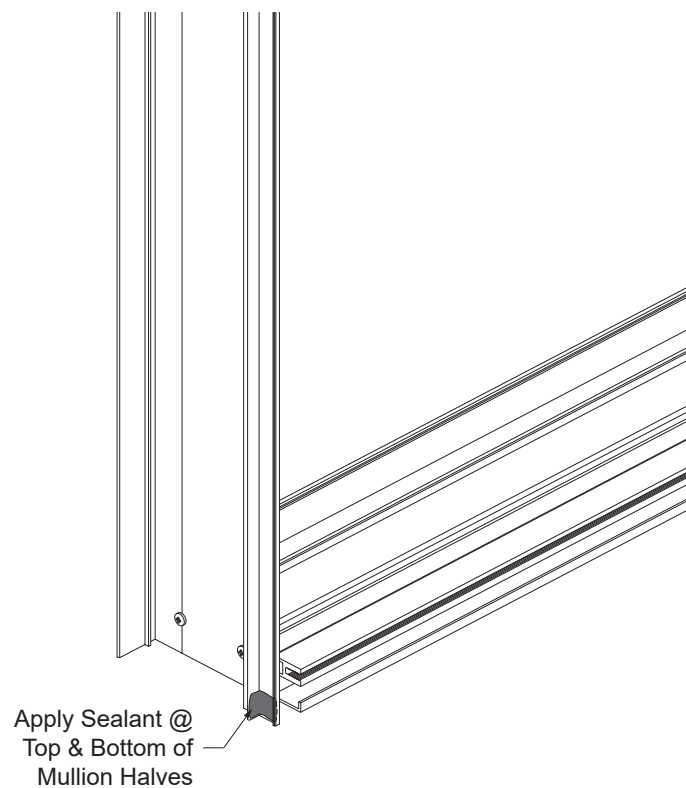

***Detail 24***  
Bottom Shown,  
Top Similar

## FRAME INSTALLATION

### STEP 15 (Continued) LADDER ANCHORING METHOD

#### Using Mullion End Anchors:

YCW 750 SplineTech™ has two possible end anchoring conditions: “T”, and “F”.

-”T” anchors are used with intermediate verticals at the head and sill.

-”F” anchors are used with jamb mullions at the head and sill.

Ladders should be pre-assembled with end anchors, and steel or aluminum reinforcing if necessary.

To install units into place, pre-attach the “F” anchor and the “T” anchor into the left jamb ladder assembly by temporarily taping them to the ladder assembly.

Temporary wood planks at the center may be used to shim the unit to approximate height until final shims are placed under the vertical mullion. Place fixed hard shims under vertical mullion halves after ladder assemblies are located.

See **Detail 25**.

End anchors should be pre-drilled for anchor bolts according to approved shop drawings or engineering calculations.

**Note:** When installing ladders, check overall frame width every fifth mullion as the wall is installed. A buildup of cumulative tolerance errors may occur, resulting in excessive DLO spacing.

As ladder assemblies are rotated into place, PM-2510 retaining screws can be fastened into the mullion tongue to hold the assemblies together.

See **Details 18 & 37**.

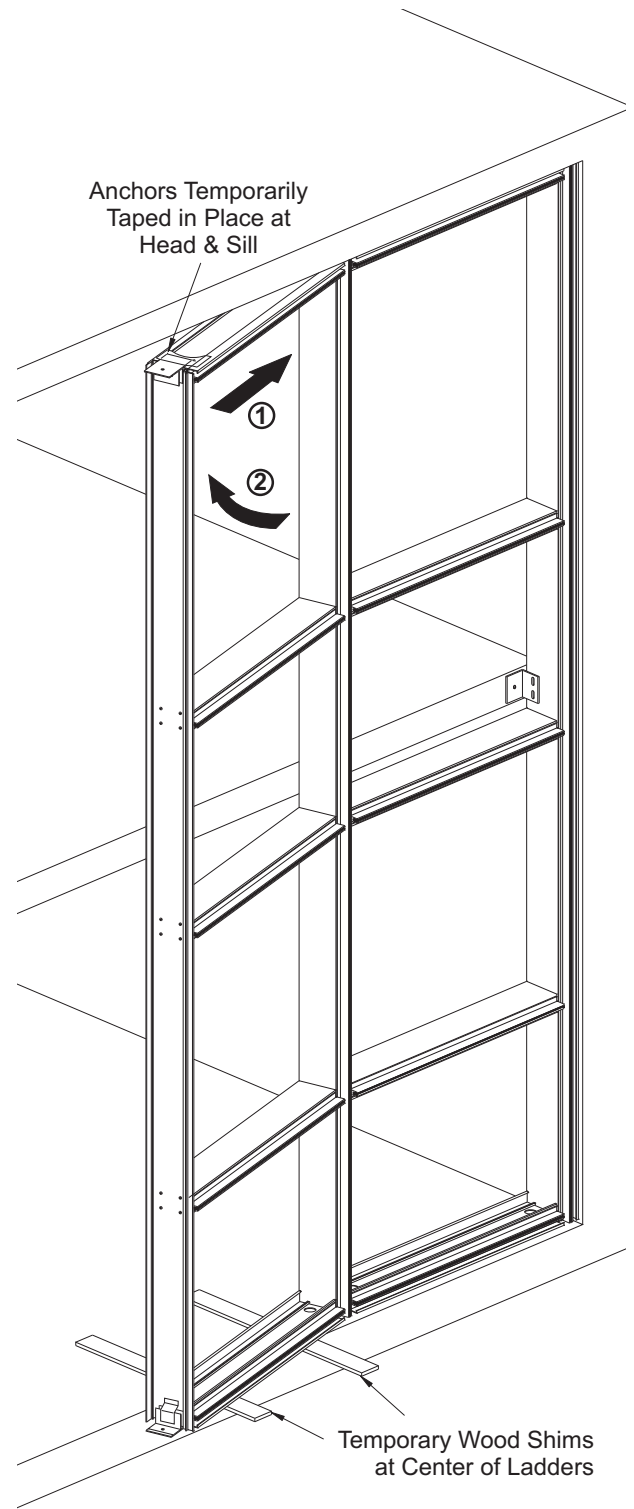

**Detail 25**

**FRAME INSTALLATION**

**STEP 16  
INSTALL WIND LOAD / DEAD LOAD ANCHORS**

-Install steel wind load and dead load anchor clips. Anchor clips are normally template or line set before mullions are hung. Outstanding leg of clip must be set at 90° to offset line. The back of the vertical mullion should set 1" from the anchoring substrate.

See **Detail 26**.

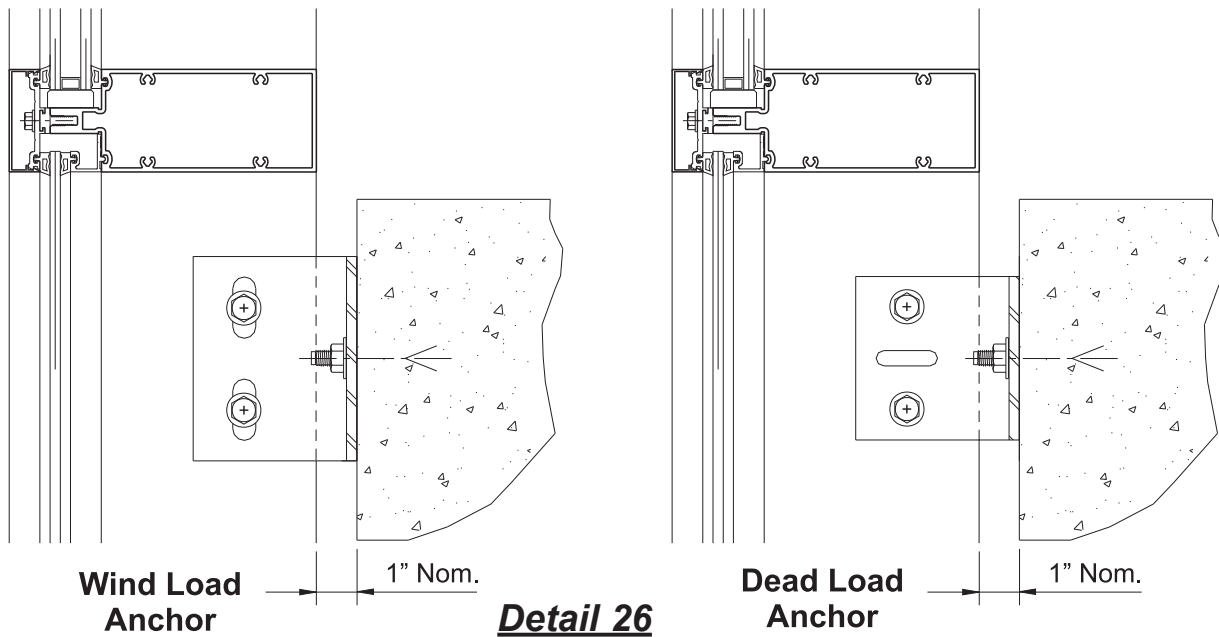

-Install, plumb, and align vertical mullions. Drill and install appropriate diameter anchor bolts. If shop drawings are not prepared by YKK AP, all anchors and bolts must be checked by a qualified engineer.

-Nylon slip pads, E3-0103, must be installed between mullion and anchor.

See **Detail 27**.

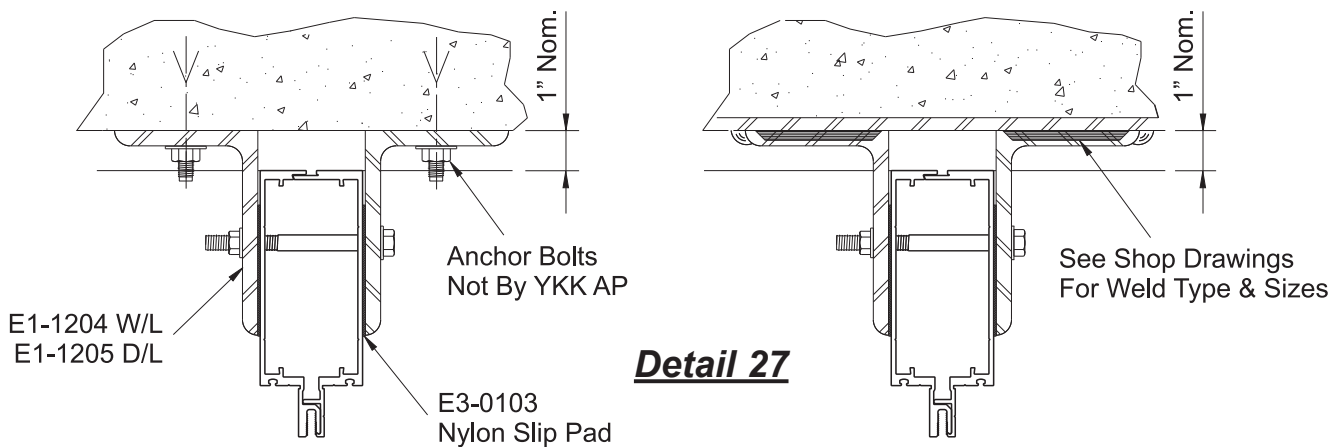

FRAME INSTALLATION

TYPICAL WIND LOAD ANCHOR

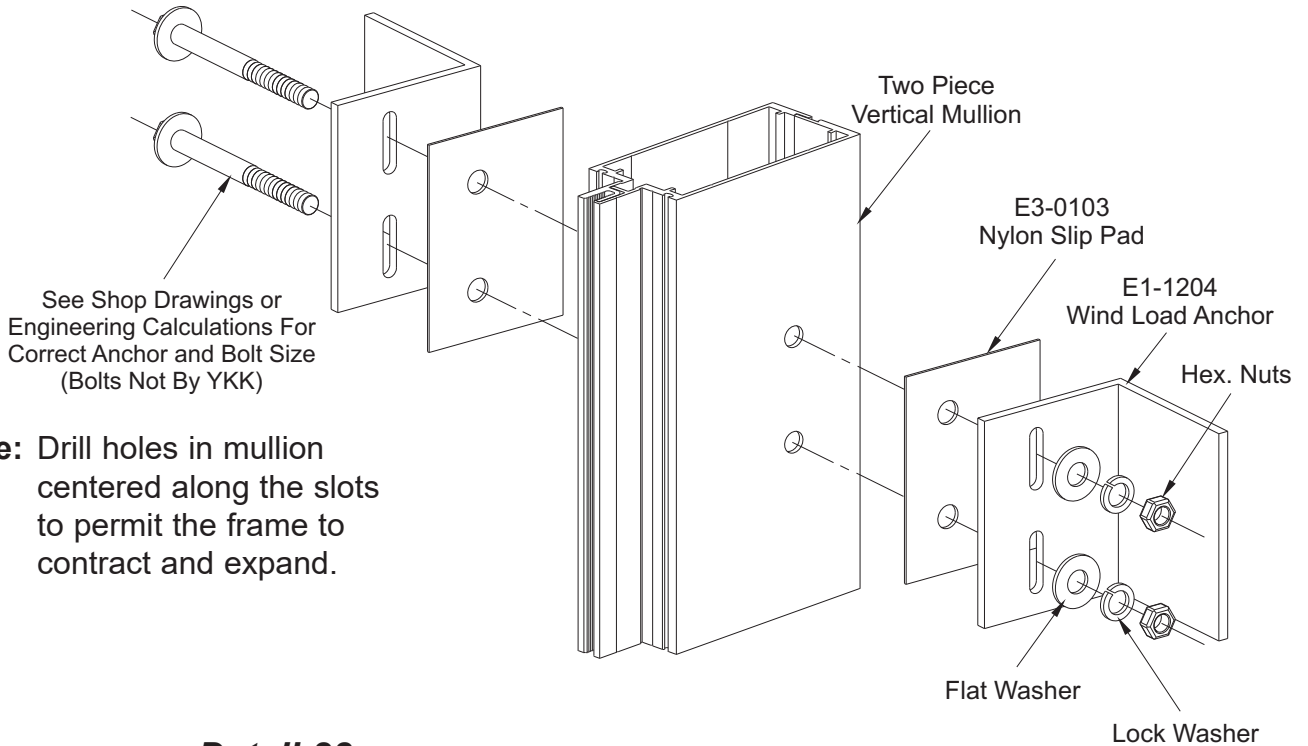

**Note:** Drill holes in mullion centered along the slots to permit the frame to contract and expand.

**Detail 28**

TYPICAL DEAD LOAD ANCHOR

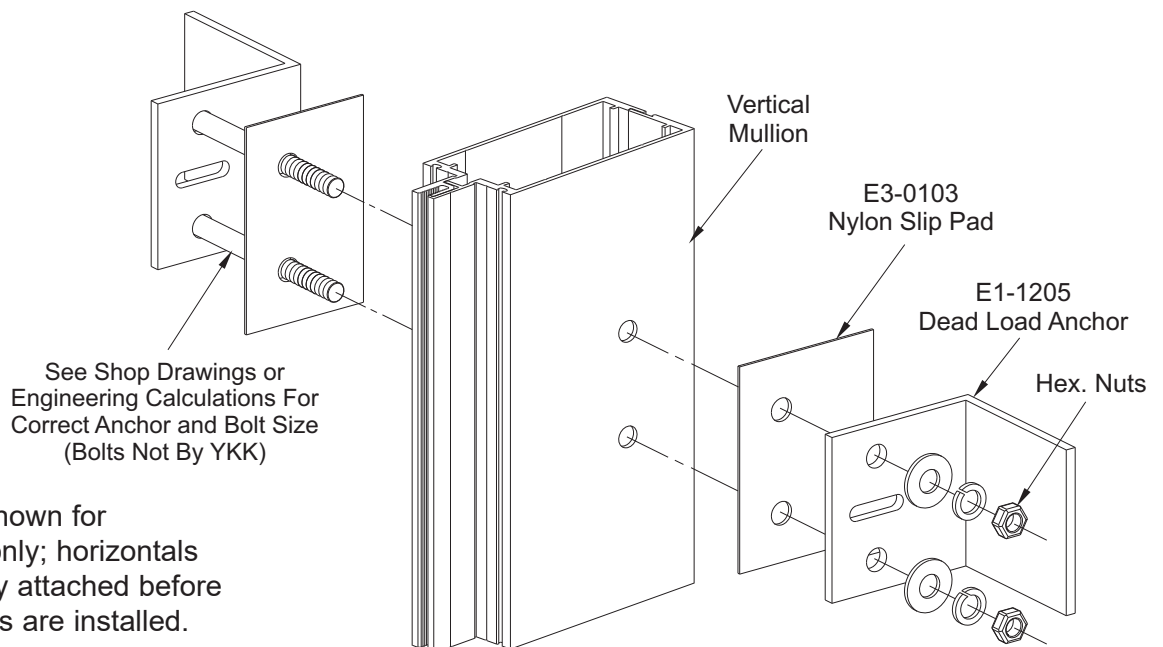

**Note:** Bolts are shown for reference only; horizontals are typically attached before anchor bolts are installed.

**FRAME INSTALLATION**

**JAMB WIND LOAD ANCHOR**

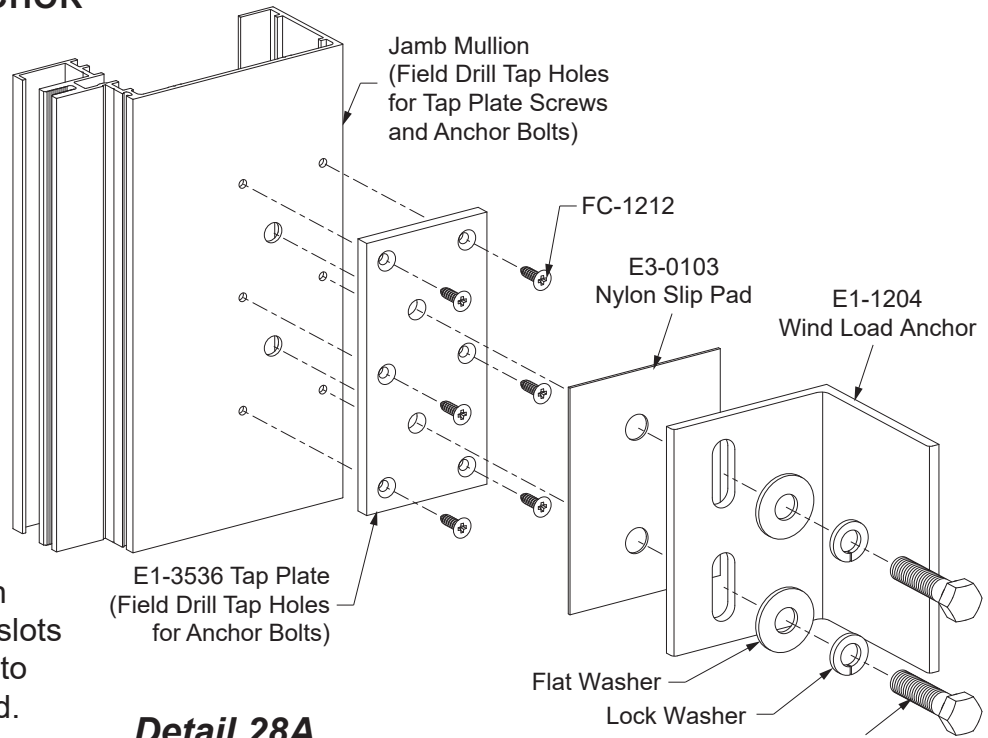

**Note:** Drill holes in mullion centered along the slots to permit the frame to contract and expand.

**Detail 28A**

See Shop Drawings or Engineering Calculations For Correct Bolt Size (Not By YKK AP)

**JAMB DEAD LOAD ANCHOR**

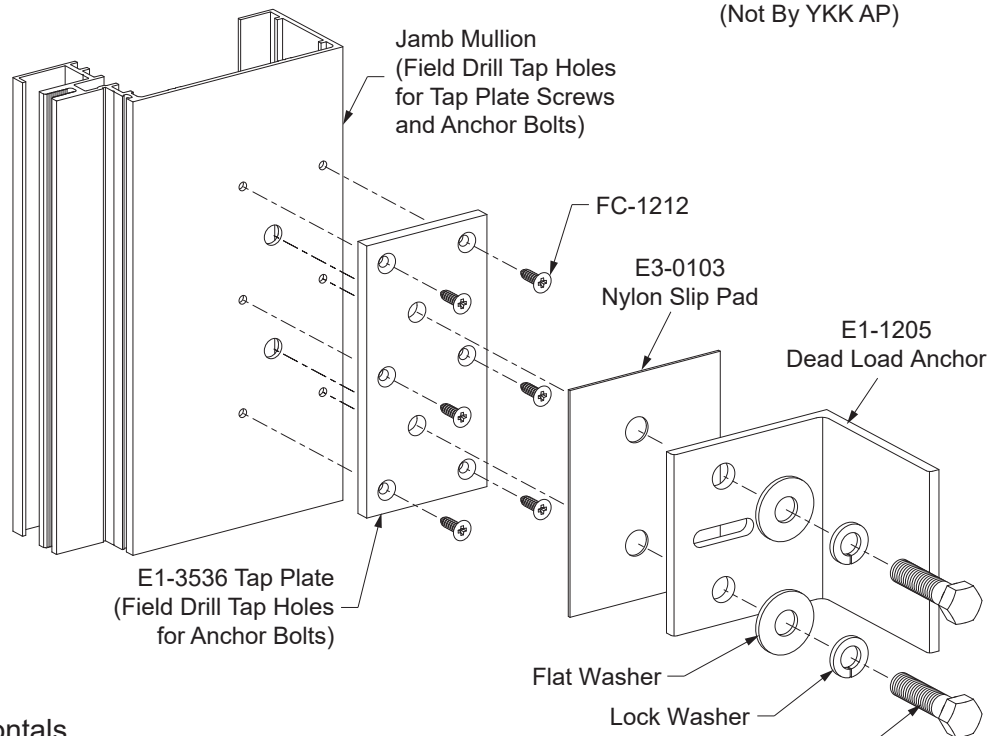

**Note:** Bolts are shown for reference only; horizontals are typically attached before anchor bolts are installed.

See Shop Drawings or Engineering Calculations For Correct Bolt Size (Not By YKK AP)



## FRAME INSTALLATION

### STEP 18 (Optional) JAMB INSTALLATION WITH JAMB ANCHORS

Optional jamb anchor clips, E1-3524 for 3-3/4" back depth and E1-3525 for 5-1/4" back depth, may be used with open back jamb members to reduce deflection at the jambs.

- Locate the jamb anchor locations on the structure according to approved shop drawings.
- Strike a plumb line the length of the frame height at the center line of the anchor fasteners.
- Provide anchor fasteners as per approved shop drawings or engineering calculations.
- Install the anchor fasteners as recommended by fastener manufacturer.
- Install the jamb mullions as instructed in the next step.

**Note:** Jamb anchors may not be feasible at last ladder installation.  
Jamb anchor clips must be installed plumb and line up straight with each other.

See **Detail 29**.

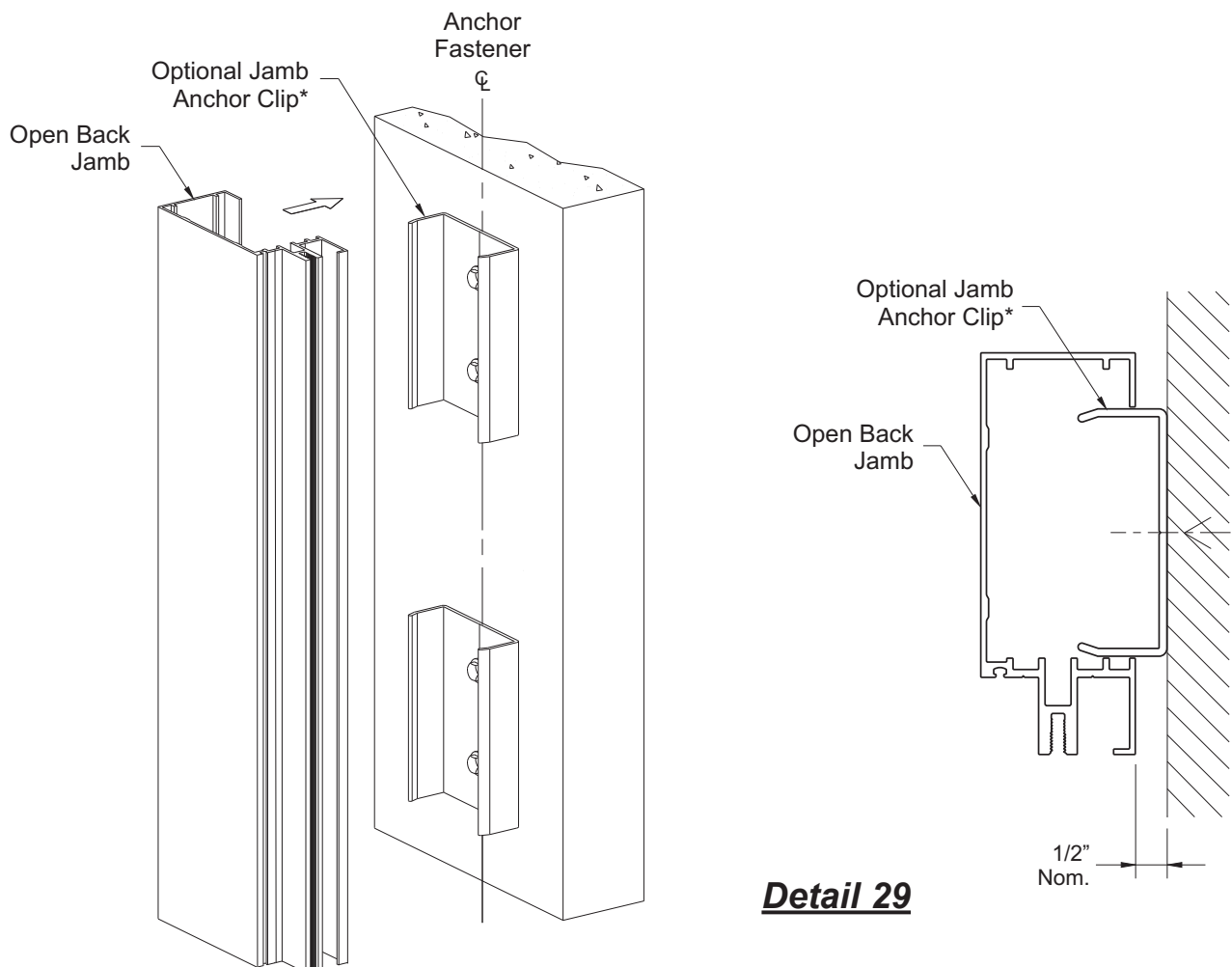

\* Anchor attachment will vary depending on job conditions. Consult YKK AP or qualified engineer.

**FRAME INSTALLATION**

**STEP 19  
INSTALL DOOR FRAME ANCHOR**

- Place ladder assembly in proper location
- Position door jamb anchor E1-3564 or E1-3565 on floor with suitable anchors.
- Drill 0.238" clear holes as shown to accommodate two PC-1220 fasteners to left and right of tongue.
- Drill and countersink 0.238" hole in location shown to accommodate FC-1212 fastener.
- Rotate next assembly into position & fasten as shown.
- Seal around base of of mullion prior to installing door frame.

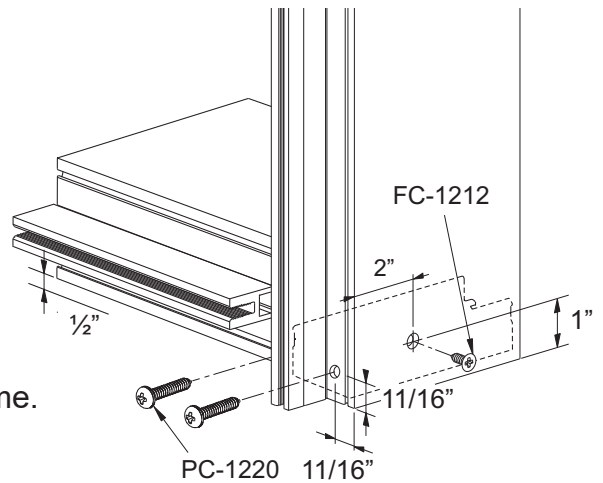

See **Detail 30**.

**Detail 30**

**STEP 20  
APPLY PERIMETER SEALANT**

- Clean the area around the perimeter of the frame with cleaner and method approved by sealant manufacturer.
- Push in backer rod between the perimeter of the frame and the substrate about 1/4".
- Apply sealant to the perimeter of the frame.
- Tool the sealant making sure that sealant provides a watertight joint.

See **Detail 31**.

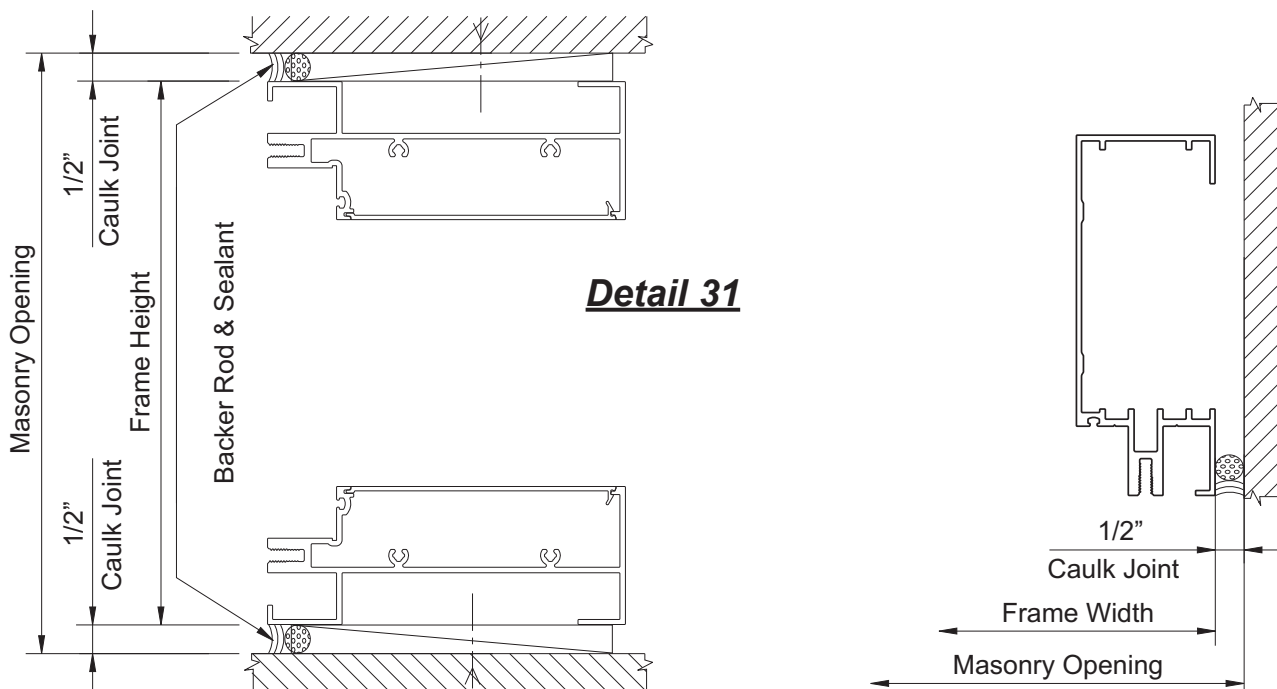

**Detail 31**

## FRAME INSTALLATION

### STEP 21 INSTALL DOOR SUBFRAMES

Refer to the **Entrances Installation Manual** for assembly of the door subframes. These subframes are typically glazed into the curtain wall framing at the jambs, and set directly upon the sill substrate without any shims. The subframe members are determined by the approved shop drawings.

-Clean all sealant contact surfaces as recommended by the sealant manufacturer.

-Fasten the mullion halves together with PC-1006 screws at 3" from each end of the mullion and at 24" maximum on center. See **Detail 33**.

-Install the jamb subframe onto the mullion with fasteners according to the approved shop drawings, setting the subframe jambs in beds of sealant as shown in **Detail 32**.

-Apply and tool sealant to the bottom of the jamb subframe as shown in **Detail 33**.

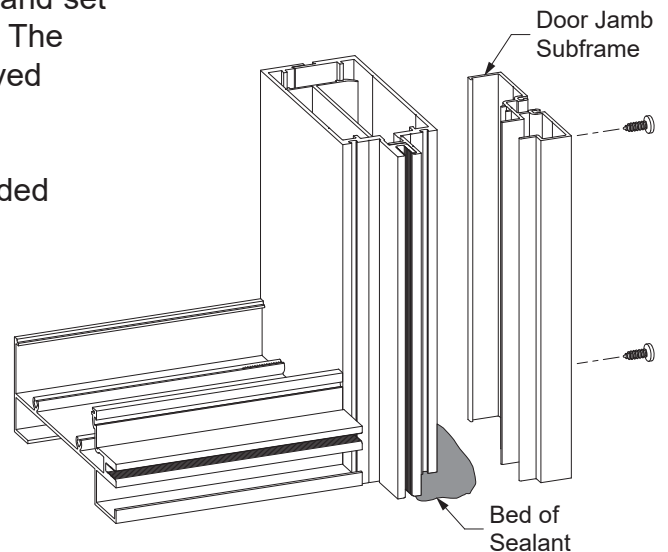

**Detail 32**

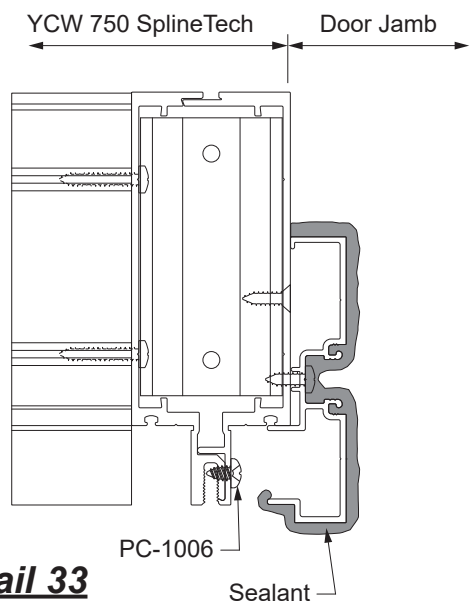

**Detail 33**

**GLAZING**

**STEP 22  
INSTALL SETTING & SIDE BLOCKS**

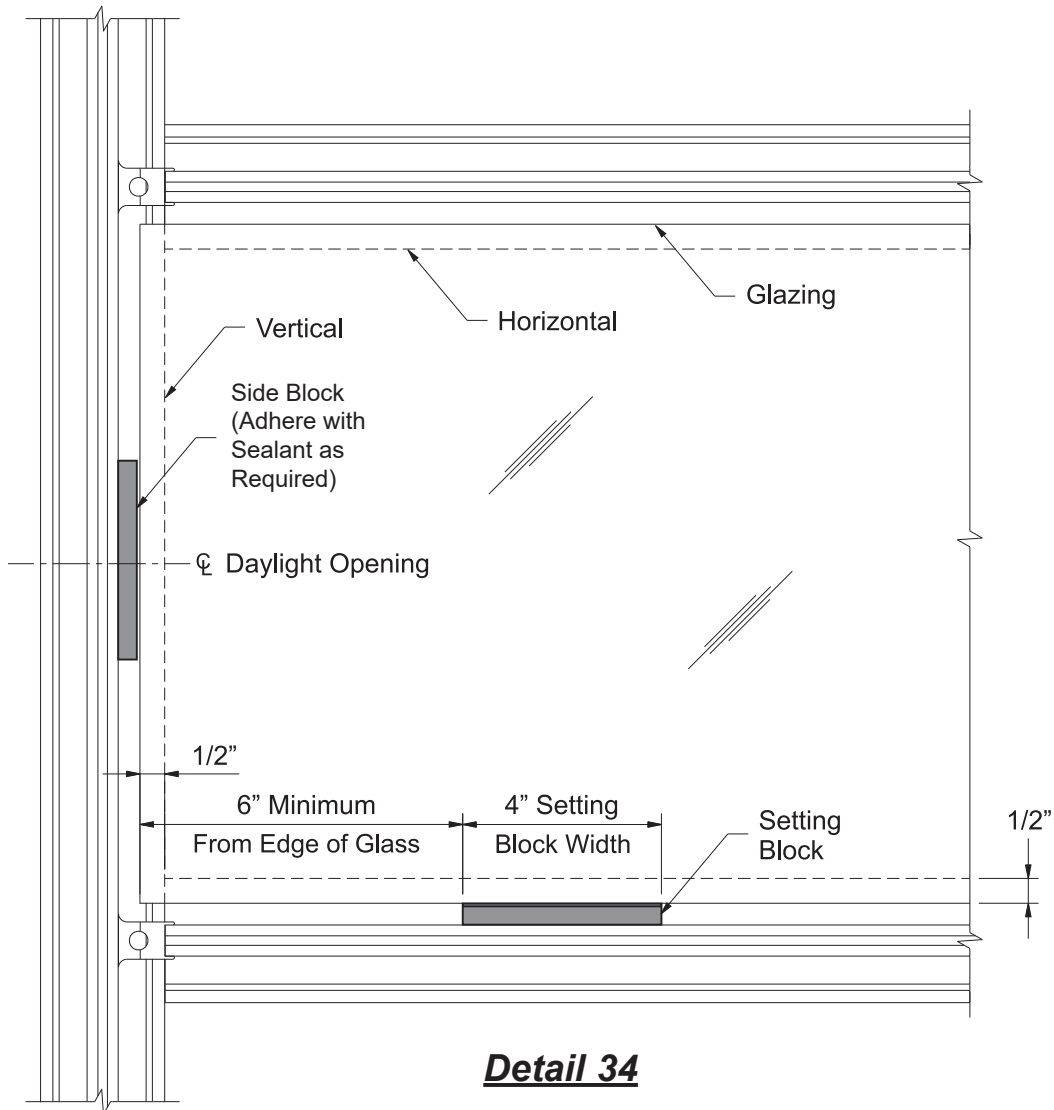

**Detail 34**

- Install setting blocks, E2-0104 for 1" glazing or E2-0112 for 1/4" glazing, at 1/4 points of D.L.O. or at 1/8 points of D.L.O. or minimum of 6" from edge of glass, whichever is greater. Consult YKK AP for setting block requirements on units that exceed 60" x 96" or 40 sq. ft.
- Install side blocks, E2-0105 (adhere with sealant) for 1" glazing or E2-0113 for 1/4" glazing, centered along the daylight opening on both sides of glazing material.

See **Detail 34**.

## GLAZING

### STEP 23 INSTALL EXTERIOR GLAZING GASKETS

- Cut exterior vertical glazing gaskets to the same length as the vertical pressure plates.
- Cut exterior horizontal glazing gaskets to daylight opening plus 1/4" per foot of opening width.
- Install vertical glazing gaskets by pushing them onto the vertical pressure plates.
- Install horizontal gaskets by pushing each end into the reglet of the pressure plate. Next press center of gasket into reglet; then push gasket into reglet working from center towards the ends. See **Detail 35**.

**Caution:** Do not stretch the gaskets.

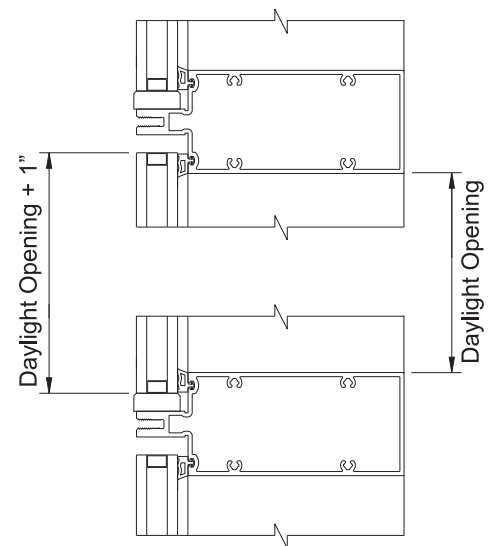
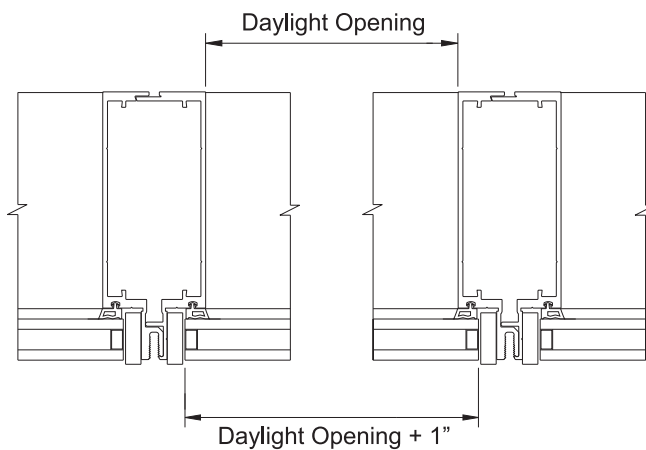

**Detail 35**

### STEP 24 INSTALL GLASS

**Vision and Spandrel Glass Size = Daylight Opening + 1" horizontally and vertically.**

- As each lite is installed, attach a temporary retaining clip, E1-1294, in the middle of each horizontal and 4" from glass edge at each end using HD-2516-W3-SS fasteners.
- Reuse the temporary retaining clips.
- Apply sealant to the face of the joint plugs just prior to installing vertical pressure plates. Do not allow sealant to skim over prior to installing pressure plates.

**Note:** Sealant must form a complete seal between the exterior gasket, pressure plate, thermal isolator, and the joint plug.

See **Detail 36**.

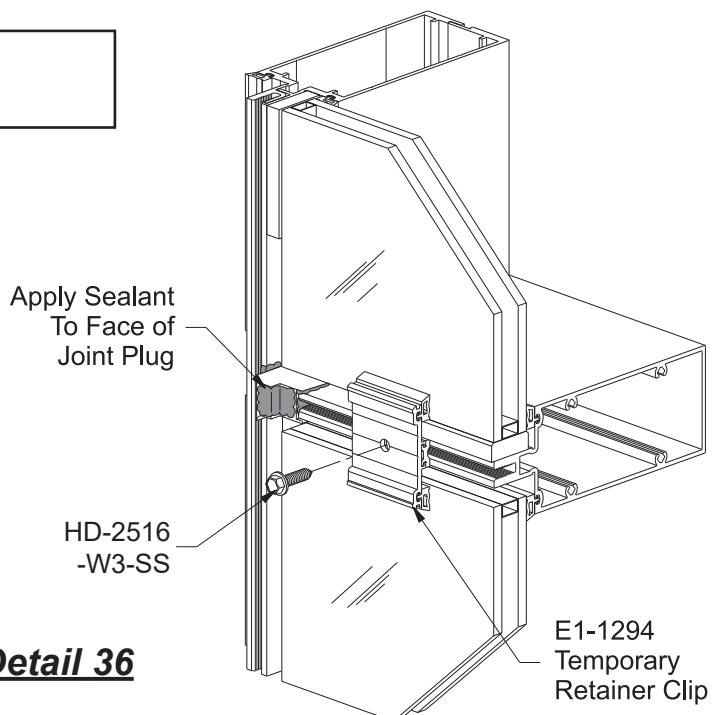

**Detail 36**

**GLAZING**

**STEP 25  
INSTALL VERTICAL PRESSURE PLATE**

To accommodate PM-2510 retaining screws used at top and bottom of vertical mullion halves during ladder assembly, vertical pressure plates must be altered as follows;

- Trim thermal isolator 1" from top and bottom.
- Apply sealant as shown immediately before installing.

See **Detail 37**.

**Installation Tip:** Additional PM-2510 retaining screws may be used as the installer deems necessary, but they must be removed prior to vertical pressure plate installation.

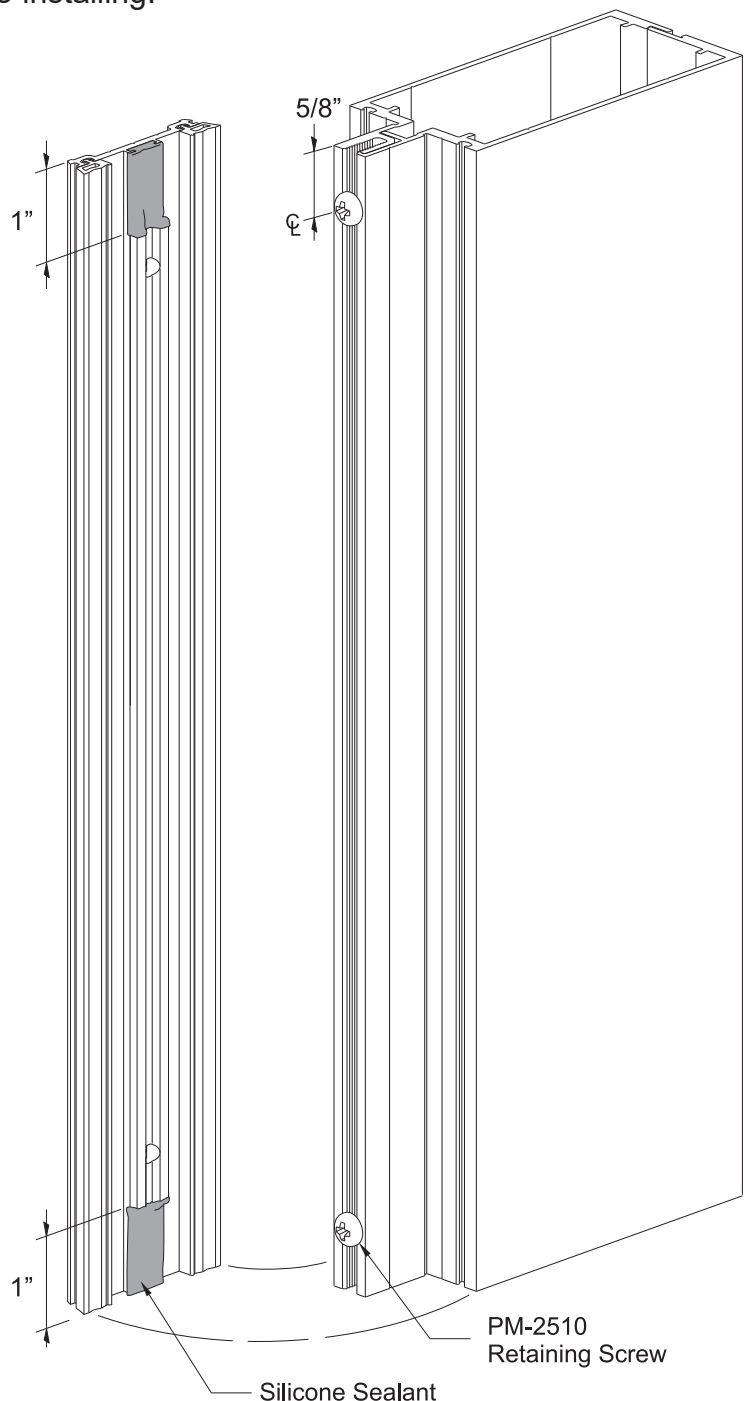

**Detail 37**

GLAZING

**STEP 26**  
**PRESSURE PLATE LAYOUT AND ASSEMBLY**

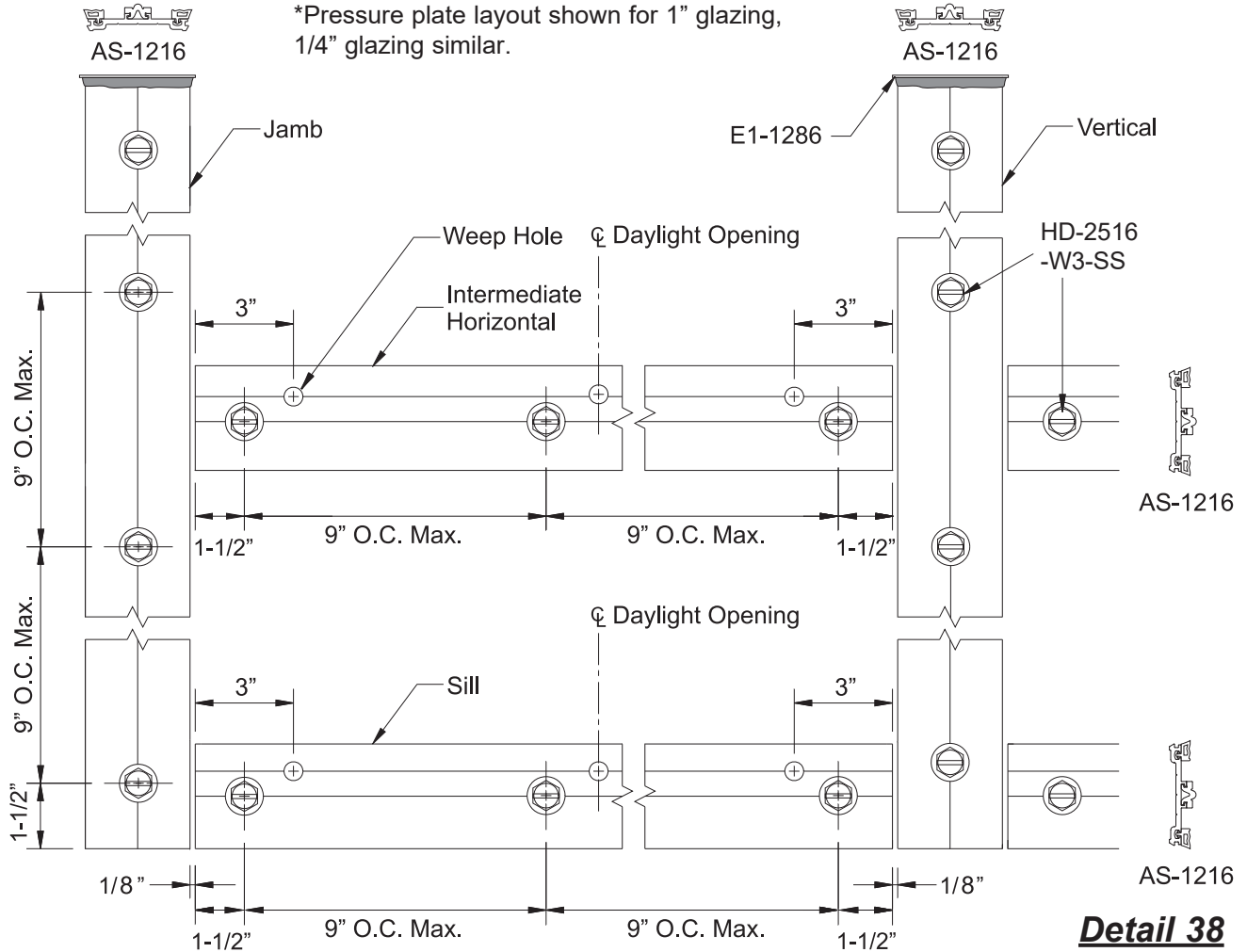

***Detail 38***

- Pressure plate stock lengths are factory punched with 0.281" diameter holes at 9" o.c. maximum. After cutting, additional holes may be required to have screws 1-1/2" from each end. See **Detail 33**.
  - At the top of the pressure plate, start an HD-2516-W3-SS screw through the pressure plate and slightly through the thermal separator.
  - Hold vertical pressure plate to the extreme top of the mullion against the end cap and start the screw into the mullion tongue, applying pressure to keep the thermal separator up against the mullion tongue.
  - Torque screws to 50 inch-pounds with a speed wrench or torque limiting screw gun.
  - Work from the top down.
  - Install vertical face cover E9-1206 using a mallet and a clean piece of lumber. Start at the top of the cover and work block and mallet down the vertical.
- See **Detail 38**.
- Center and install horizontal pressure plates in opening, leaving a 1/8" gap at the ends.
  - Starting at the center of each pressure plate, tighten each retainer screw to 50 inch-pounds.

**GLAZING****STEP 27  
INSTALL EXTERIOR FACE COVERS**

- Apply and tool sealant to the gap between horizontal pressure plate and the vertical face cover.
- Install horizontal face cover E9-1206. Start at one end and work block and mallet across the horizontal.

See **Detail 39**.

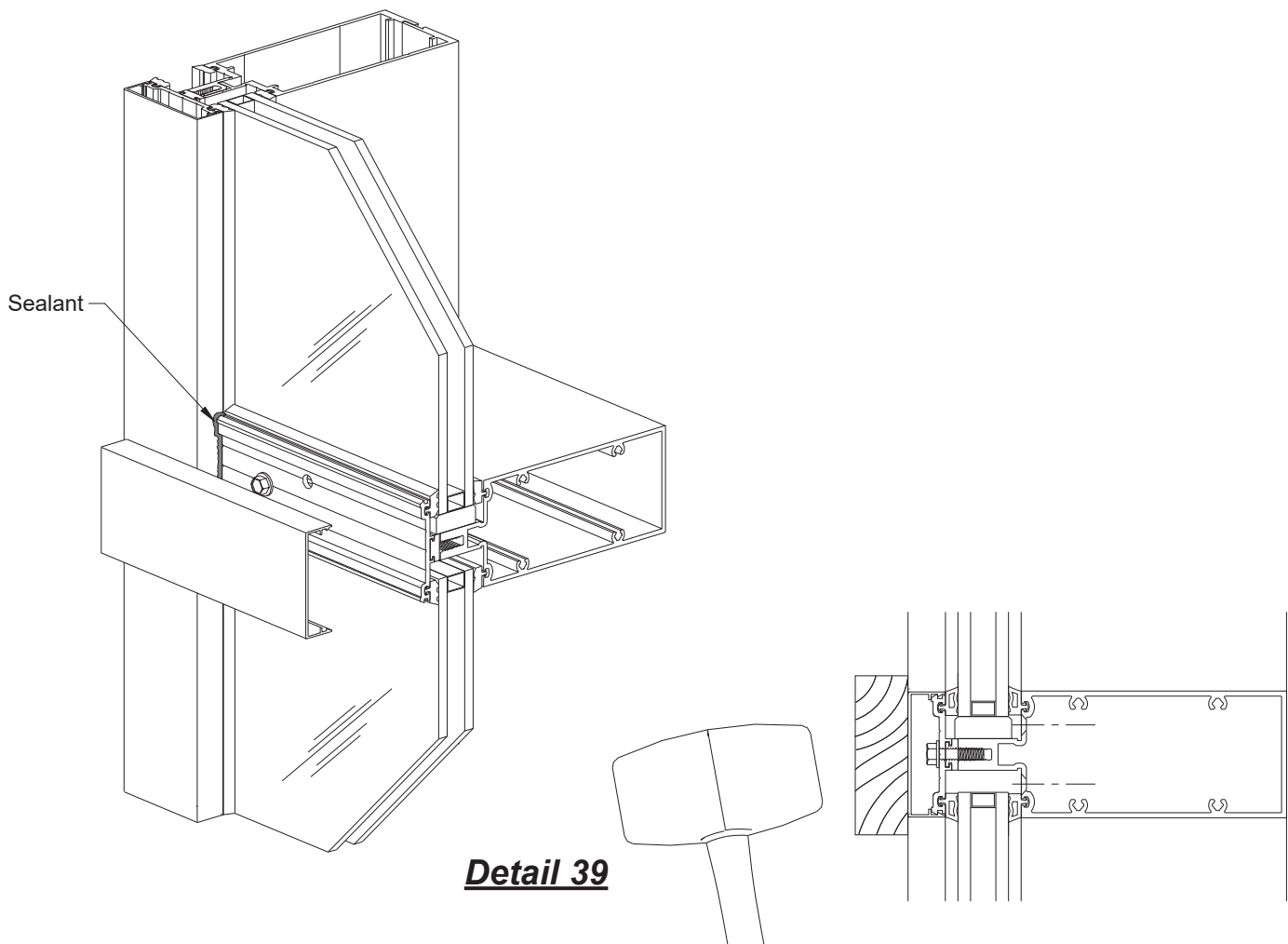
**STEP 26  
INSTALL HEAD AND SILL COVERS**

- Snap in Horizontal Flush Filler E9-3162, or E9-3595 at head and sill as required.



GLAZING

**STEP 27A**  
**INSTALL OPTIONAL DEEP FACE COVERS**

Installation of a deep vertical cover is similar to that of the standard face cover, except a fastener is required to keep the cover from possibly sliding down over time. Typically, the face cover is fastened with one PC-0808-SS screw at a horizontal to be concealed by the horizontal face cover, unless otherwise specified on the approved shop drawings.

- For concealed fastener locations, drill a 0.189" diameter hole into the side of the face cover, 7/16" from the snap interface of the cover. Snap on the deep cover at its intended location. Using the clear hole as a pilot hole, drill a 0.141" diameter tap hole into the leg on the deep pressure plate. Secure the face cover in place with a PC-0808-SS.
- If the face cover requires it to be fastened at an exposed location, drill a 0.189" diameter countersunk hole into the side of the cover. Snap on the deep cover at its intended location. Using the clear hole as a pilot hole, drill a 0.141" diameter tap hole into the leg on the deep pressure plate. Secure the face cover in place with an FC-0808-SS screw.
- Continue to install the horizontal pressure plate and face cover as specified on **Pages 35 & 36**.

See **Detail 40**.

Installation of horizontal deep face covers is similar except the screw is always on the top of the face cover with its head set in sealant.

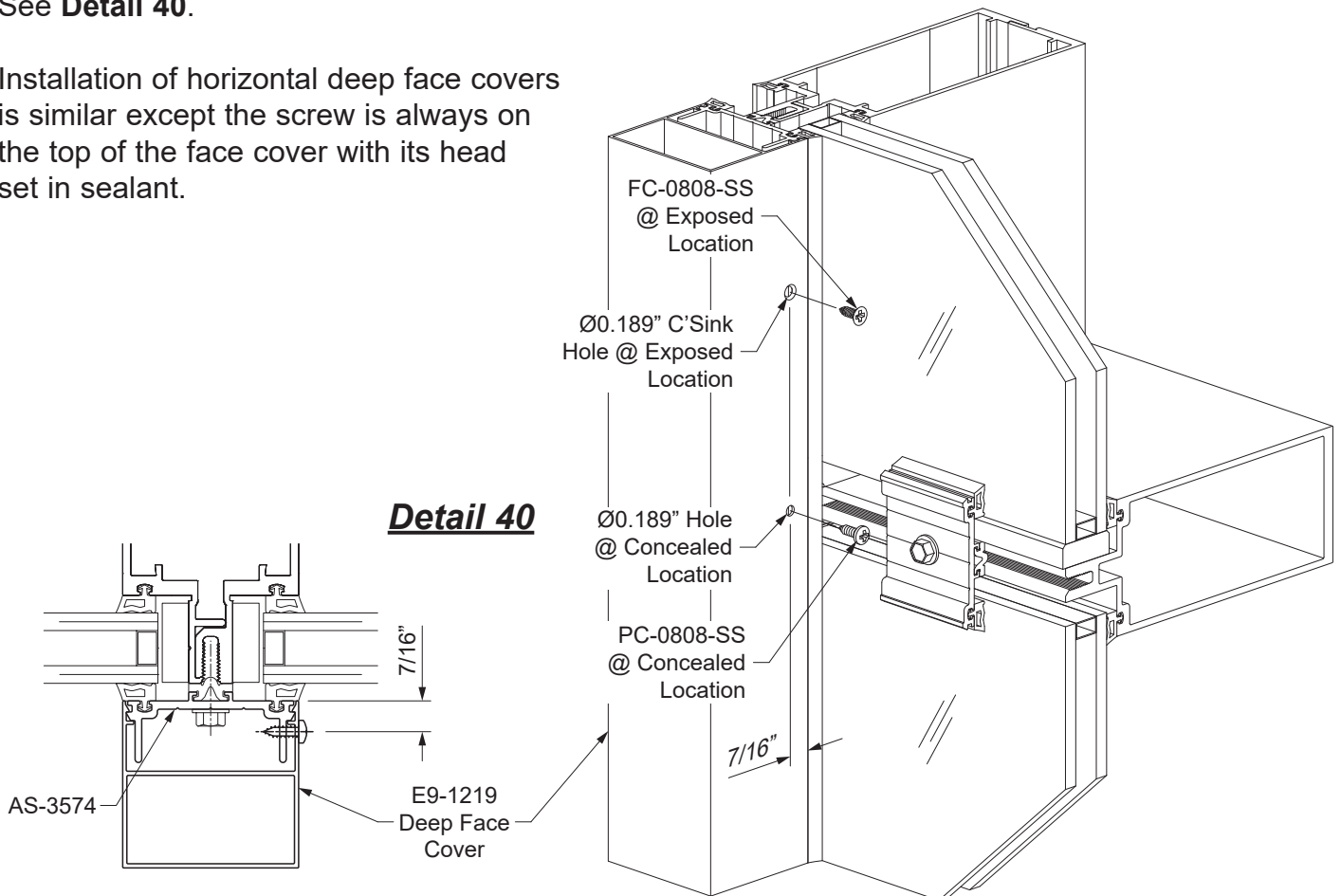



101 Marietta Street NW  
Suite 2100  
Atlanta, Georgia 30303  
[www.ykkap.com](http://www.ykkap.com)