

# YCW 750 XT High Performance Curtain Wall System

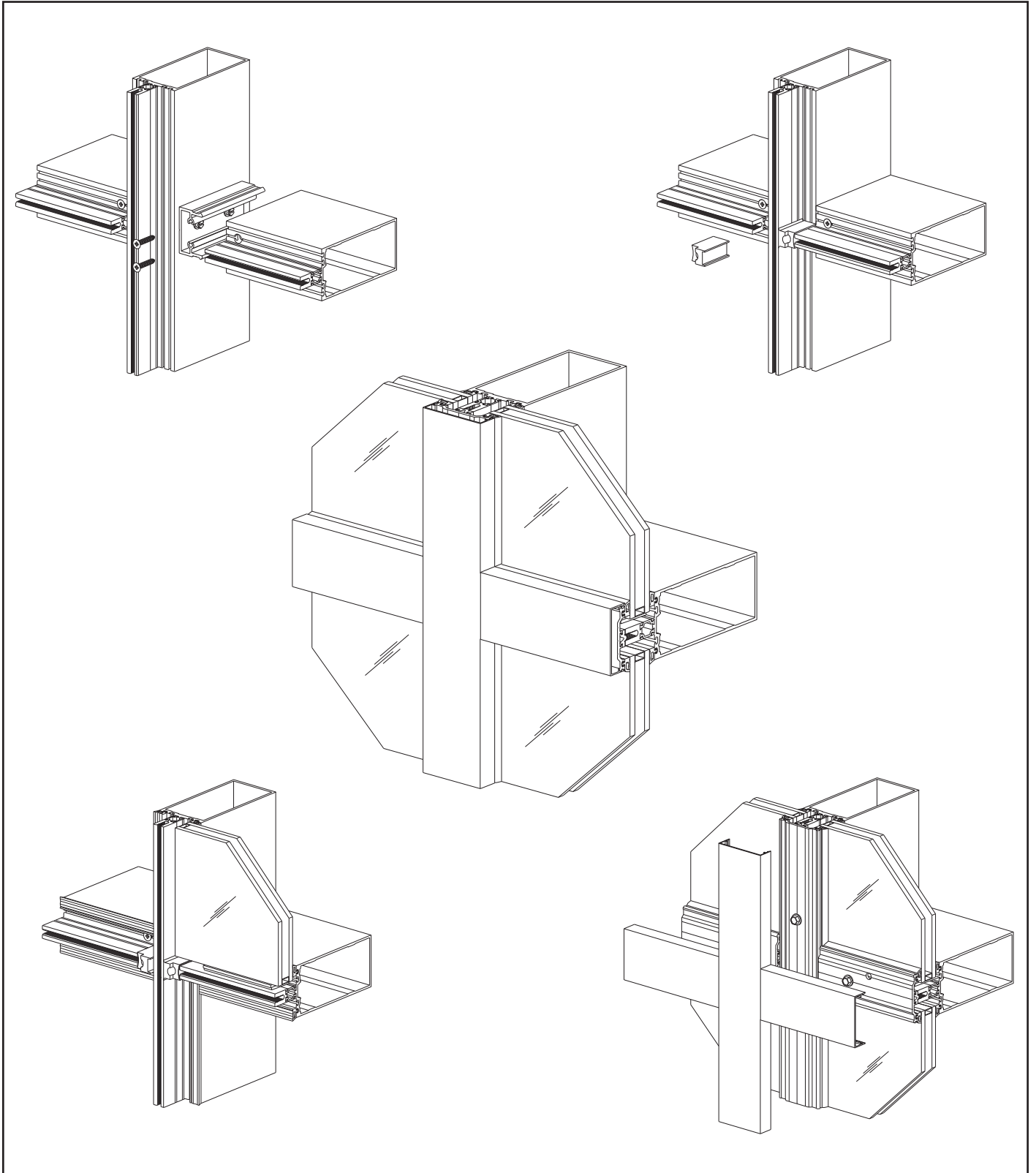

## Installation Manual















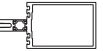



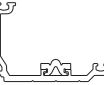





## TABLE OF CONTENTS

Installation Notes .....	Page ii
<b>PARTS DESCRIPTION</b>	
YCW 750 XT Framing Members / Accessories.....	Page 1 to 13
<b>FRAME FABRICATION</b>	
Vapor Barrier .....	Page 14
Anchoring Methods/Framing Types.....	Pages 15 & 16
Fabricate Vertical Mullions .....	Pages 17 to 19
Using Steel Reinforcing .....	Page 20
Assemble 90° Corner Mullions .....	Page 21
Attach Shear Blocks/Clips for Horizontals.....	Pages 22 & 23
Attach “J” Anchors .....	Page 24
Fabricate Horizontal Members .....	Pages 25 to 29
Fabricate Pressure Plates .....	Pages 30
Fabricate Face Covers .....	Page 31
Fabricate Sill Flashing .....	Page 32
<b>FRAME INSTALLATION</b>	
Typical Vertical Splice .....	Pages 33 & 34
Install Continuous Perimeter Anchor.....	Page 35
Jamb / Vertical Installation with Perimeter Anchors.....	Page 36
Jamb / Vertical Installation with Mullion End Anchors.....	Pages 37 to 39
Install Wind Load/Dead Load Anchors .....	Pages 40 & 41
Attach Horizontal Members .....	Pages 42 to 45
Install Door Subframes (35XT/50XT Doors Only).....	Page 46
Apply Perimeter Sealant.....	Page 47
Install Sill Flashing.....	Pages 48 & 49
Install Joint Plugs.....	Page 50
Install 90° Outside Corner Mullion Trim .....	Pages 51 & 52
<b>GLAZING</b>	
Install Glazing Adaptors.....	Page 53
Install Interior Glazing Gaskets .....	Page 54
Install Setting & Side Blocks .....	Pages 55 & 56
Install Exterior Glazing Gaskets .....	Page 57
Install Glass .....	Page 57
Pressure Plate Layout and Assembly .....	Page 58
Install Flat Door Jamb Subframes for 25T/35T/50T Doors .....	Page 59
Install Exterior Face Covers .....	Page 60
<b>DOOR SUBFRAME INSTALLATION</b>	
Install Door Stop for 25T/35T/50T Doors .....	Page 61
Fasten Door Subframe at Transom.....	Page 61

## Installation Notes

1. Do not drop, roll or drag boxes of aluminum framing. Move and stack boxes with proper support to prevent distortion. If fork lifts are used, be especially careful about striking the boxes when lifting or moving.
2. Store in a dry, out of the way area. If rain exposure, condensation or any water contact is likely, then all packaging material should be removed. Wet packaging materials will discolor and may stain aluminum finishes and paints.
3. All materials should be checked for quality and quantity upon receipt, YKK AP must be notified immediately of any discrepancies in shipment. Check to make sure that you have the required shims, sealants, supplies and tools necessary for the installation.
4. Carefully check the openings and surrounding conditions that will receive your material. Remember, if the construction is not per the construction documents, it is your responsibility to notify the general contractor in writing. Any discrepancies must be brought to the general contractor's attention before you proceed with the installation.
5. Gather your shop drawings, materials, packing list, and this installation manual. Carefully review parts location, the sequence it goes therein, when you glaze it and how you seal it. Installation instructions are of a general nature and may not cover every condition you will encounter. The shop drawings and/or installation manuals were prepared specifically for the product.
6. Any material substitutions must be of equal or greater quality.
7. Make certain that material samples have been sent for compatibility testing for all manufacturer's sealants involved. Make certain sealants have been installed in strict accordance with the manufacturer's recommendations and specifications.
8. Remember to isolate, in an approved manner, all aluminum from uncured masonry or other incompatible materials.
9. System-to-structure fasteners are not supplied by YKK AP. Fasteners called out on shop drawings are to indicate minimum sizes for design loading.
10. Please contact the YKK AP DirecTech application engineering department for any project specific condition not covered by these instructions.
11. YKK AP storefront and/or curtain wall framing is typically completed before drywall, flooring and other products which may still be in process. Take the extra time to wrap and protect the work produced.
12. Cutting tolerances are plus zero, minus one thirty second unless otherwise noted.
13. Check our website, [www.ykkap.com](http://www.ykkap.com), for the latest installation manual update prior to commencing work.

## FRAMING MEMBERS (1" GLAZING)

	<b>Horizontal</b> 2-1/2" x 3-3/4"	<b>BE9-3948</b>		<b>Flush Filler</b> Use With BE9-3904	<b>E9-3162</b>
	<b>Jamb / Mullion / Horizontal</b> 2-1/2" x 3-3/4"	<b>BE9-3942</b>		<b>Flush Filler</b> Use With BE9-3914	<b>E9-8489</b>
	<b>Horizontal</b> 2-1/2" x 5-1/4"	<b>BE9-3910</b>		<b>Standard Pressure Plate</b> E9-3906 with EPDM Isolator Drilled 9" O.C.	<b>AS-3906</b>
	<b>Head / Sill / Horizontal</b> 2-1/2" x 5-1/4"	<b>BE9-3904</b>		<b>Perimeter Pressure Plate</b> E9-3907 with EPDM Isolator Drilled 9" O.C.	<b>AS-3907</b>
	<b>Jamb / Mullion / Horizontal</b> 2-1/2" x 5-1/4"	<b>BE9-3901</b>		<b>90° Outside Corner Adaptor</b>	<b>BE9-3912</b>
	<b>Head / Sill / Horizontal</b> 2-1/2" x 6-3/4"	<b>BE9-3914</b>		<b>1-1/2" x 1-1/2" x 1/8" Angle</b> Used at 90° Outside Corner	<b>E9-9303</b>
	<b>Jamb / Mullion / Horizontal</b> 2-1/2" x 6-3/4"	<b>BE9-3916</b>		<b>3/4" x 3/4" x 1/8" Angle</b> Used at 90° Outside Corner	<b>E9-9307</b>
	<b>Outside Corner Mullion</b> 2-1/2" x 3-3/4"	<b>E9-1250</b>		<b>Face Cover</b> 2-1/2" x 3/4"	<b>E9-1206</b>
	<b>Outside Corner Mullion</b> 2-1/2" x 5-1/4"	<b>E9-1246</b>		<b>90° Outside Corner Interior Cover Base</b> Use with E9-1281	<b>E9-1280</b>
	<b>Outside Corner Mullion</b> 2-1/2" x 8-1/4"	<b>E9-8121</b>		<b>90° Outside Corner Interior Cover</b> For 5-1/4" Back Depth Only	<b>E9-1281</b>
	<b>Sill Flashing</b>	<b>BE9-3918</b>		<b>90° Outside Corner Interior Cover Base</b> Use with E9-7762	<b>E9-3556</b>
	<b>Flush Filler</b> Use With BE9-3948	<b>E9-3595</b>		<b>90° Outside Corner Interior Cover</b> For 8-1/4" Back Depth Only	<b>E9-7762</b>

\*Splay mullions and other face covers are available, contact YKK AP.

## FRAMING MEMBERS (1" GLAZING)











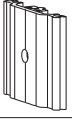

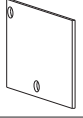



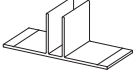

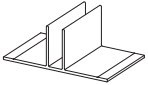

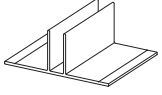

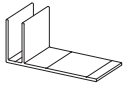

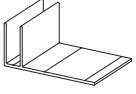
	<b>Single Acting Transom Bar</b> For 35XT/50XT Doors** Elastomer Weathering E2-0051 Not Included	<b>BE9-1532</b>		<b>Door Jamb Pocket Subframe</b> For 25T/35T/50T Doors Use with AS-1539	<b>BE9-1526</b>
	<b>Door Jamb</b> For 35XT/50XT Doors** Use with BE9-1533	<b>BE9-3650</b>		<b>Door Stop</b> For 25T/35T/50T Doors E2-0051 Included Use with BE9-1526	<b>AS-1539</b>
	<b>Glazing Adaptor</b> For 1/4" Glazing	<b>E9-1220</b>		<b>Perimeter Anchor</b>	<b>E9-1223</b>
	<b>Door Stop</b> For 35XT/50XT Doors** E2-0051 Not Included Use with BE9-3650	<b>BE9-1533</b>		<b>Perimeter Channel</b>	<b>E9-1231</b>
	<b>Single Acting Transom Bar</b> For 25T/35T/50T Doors E2-0051 not Included	<b>BE9-2582</b>			

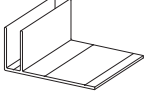
\*\* Note: 35XT/50XT Doors to be discontinued after April 30, 2024.

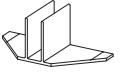

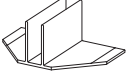

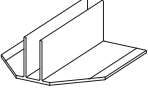
## ACCESSORIES (1" GLAZING)

	<b>"J" Anchor</b> For 3-3/4" Depth Members Use (2) FC-1220 & Req. Fasteners	<b>E1-3501</b>		<b>90° Outside Corner Shear Block</b> For 5-1/4" Depth Members, Use (2) HF-2510-W1 & (2) FC-1212	<b>E1-3504A</b>
	<b>"J" Anchor</b> For 5-1/4" Depth Members Use (2) FC-1220 & Req. Fasteners	<b>E1-3502</b>		<b>90° Outside Corner Shear Block</b> For 6-3/4" Depth Members, Use (2) HF-2510-W1 & (2) FC-1212	<b>E1-3506A</b>
	<b>Standard Shear Block</b> For 3-3/4" Depth Members Use (2) HF-2510-W1 & (2) FC-1220	<b>E1-3503</b>		<b>Setting Block Chair</b>	<b>E1-3603</b>
	<b>Standard Shear Block</b> For 5-1/4" Depth Members Use (2) HF-2510-W1 & (2) FC-1220	<b>E1-3504</b>		<b>Mullion Joint Sleeve</b> For BE9-3942	<b>E1-1211</b>
	<b>Standard Shear Block</b> For 6-3/4" Depth Members Use (2) HF-2510-W1 & (2) FC-1220	<b>E1-3506</b>		<b>Mullion Joint Sleeve</b> For BE9-3901	<b>E1-1210</b>
	<b>90° Outside Corner Shear Block</b> For 5-1/4" Depth Members, Use (2) HF-2510-W1 & (2) FC-1212	<b>E1-3503A</b>		<b>Mullion Joint Sleeve</b> For BE9-3916	<b>E1-1365</b>

## ACCESSORIES (1" GLAZING)





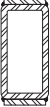





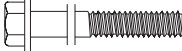

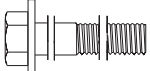

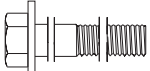

	<b>Face Cover Splice Sleeve</b> For E9-1206 Face Cover	<b>E1-1202</b>		<b>Temporary Glass Retainer</b> 2" Long	<b>E1-3612</b>
	<b>Standard Mullion End Cap</b> 2-1/2" x 2-3/8" x 0.050"	<b>E1-3605</b>		<b>Setting Block</b> For 1" Glazing	<b>E2-0513</b>
	<b>Sill Flashing End Dam</b> 2.157" x 1-3/8" x 0.050"	<b>E1-3611</b>		<b>Setting Block</b> For 1/4" Glazing	<b>E2-0192</b>
	<b>Corner Mullion End Cap</b>	<b>E1-3608</b>		<b>Side Block</b> With pressure sensitive adhesive	<b>E2-0133</b>
	<b>Intermediate Vertical "T" End Anchor*</b> For BE9-3942	<b>E1-1223</b>		<b>Standard Joint Plug</b> For 1" Glazing	<b>E2-3603</b>
	<b>Intermediate Vertical "T" End Anchor*</b> For BE9-3901 & E9-3401	<b>E1-1222</b>		<b>End Dam Plug</b> Used with E9-1223 Perimeter Anchor	<b>E2-0505</b>
	<b>Intermediate Vertical "T" End Anchor*</b> For BE9-3916	<b>E1-3601</b>		<b>Structural Tape</b>	<b>E2-0679</b>
	<b>Jamb "F" End Anchor*</b> For BE9-3942	<b>E1-1235</b>		<b>Nylon Slip Pad</b> For Wind Load & Dead Load Anchor	<b>E3-0103</b>
	<b>Jamb "F" End Anchor*</b> For BE9-3901	<b>E1-1234</b>		<b>Wind Load Anchor*</b> Refer to Shop Drawings For Anchor Dimensions	<b>E1-1204</b>
	<b>Jamb "F" End Anchor*</b> For BE9-3916	<b>E1-3602</b>		<b>Dead Load Anchor*</b> Refer to Shop Drawings For Anchor Dimensions	<b>E1-1205</b>
	<b>Corner "T" End Anchor</b> For 3-3/4" Depth Members	<b>E1-1207A</b>		<b>Interior/Exterior Glazing Gasket</b>	<b>E2-0120</b>
	<b>Corner "T" End Anchor</b> For 5-1/4" Depth Members	<b>E1-1209A</b>		<b>Sill Flashing Gasket</b>	<b>E2-0241</b>
	<b>Corner "T" End Anchor</b> For 8-1/4" Depth Members	<b>E1-3571A</b>		<b>Corner Condition Gasket</b>	<b>E2-0354</b>

## ACCESSORIES (Continued, 1" GLAZING)

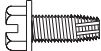





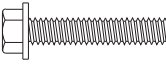



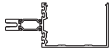

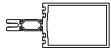



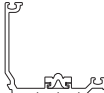

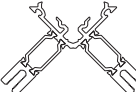



	<p><b>Elastomer Weathering</b> Used with BE9-1532 &amp; BE9-1533</p>	<p><b>E2-0051</b></p>		<p><b>Jamb Anchor Plate</b> 3" x 6" x 5/16" Thk.</p> <p><b>E1-3536</b></p>
	<p><b>Steel Reinforcing</b> 2" x 4" x 1/4" Steel Tube For BE9-3901 &amp; BE9-3916</p>	<p><b>E1-0162</b></p>		<p><b>Drill Fixture</b></p> <p><b>H-7210</b></p>
	<p><b>Steel Reinforcing</b> 2" x 4" x 1/4" Steel Tube &amp; (2) 1/4" x 1-3/4" Steel Bars For BE9-3901 &amp; BE9-3916</p>	<p><b>E1-0154</b></p>		



## FASTENERS (1" GLAZING)

	<b>#12 x 3/4" FHSMS Type AB</b> Zinc Plated Steel For Attachment of Horizontal to Corner Shear Block	<b>FC-1212</b>		<b>1/4"-20 x 3-1/2" HWHMS</b> Zinc Plated Steel For Attachment of "J" Anchor at Intermediate Vertical	<b>HM-2556 -W3</b>
	<b>#12 x 1-1/4" FHSMS Type AB</b> Zinc Plated Steel For Attachment of Horizontal to Shear Block	<b>FC-1220</b>		<b>1/2"-13 x 2" HWHMS</b> Zinc Plated Steel, For Attachment of Windload/Deadload Anchor at Jamb	<b>HM-5032</b>
	<b>#14 x 5/8" FHSMS Type AB</b> Zinc Plated Steel For Attachment of Mullion End Caps	<b>FC-1410</b>		<b>1/2"-13 x 4-1/2" HWHMS</b> Zinc Plated Steel, For Attachment of Windload/Deadload Anchor at Mullion	<b>HM-5072</b>
	<b>#8 x 5/8" PHSMS Type AB</b> Zinc Plated Steel For Attachment of Glazing Adaptor E9-1220	<b>PC-0810</b>		<b>1/2"-13 Nut HHMS</b> Zinc Plated Steel For Attachment of Mid-Anchors (Wind Load / Dead Load)	<b>HM-5000</b>
	<b>#10 x 5/8" PHSMS Type AB</b> Zinc Plated Steel For Attachment of Sill Flashing BE9-3918	<b>PC-1010</b>		<b>1/4"-20 Nut HHMS</b> Zinc Plated Steel For Attachment of "J" Anchor	<b>HM-2500</b>
	<b>#8 x 1/2" PHSMS Type F</b> Stainless Steel, For Attachment of Splice Sleeve Face Covers	<b>PF-0808 -SS</b>		<b>1/4" Flat Washer</b> Zinc Plated Steel For Attachment of "J" Anchor	<b>WW-2500</b>
	<b>1/4"-20 x 5/8" HWHS Type F</b> Zinc Plated Steel For Attachment of Standard Shear Block to Vertical	<b>HF-2510 -W1</b>		<b>1/2" Flat Washer</b> Zinc Plated Steel, For Attachment of Mid-Anchors (Wind Load / Dead Load)	<b>WW-5000</b>
	<b>1/4"-20 x 1" HWHS Type F</b> , Zinc Plated Steel, For Attachment of Standard Shear Block to Vertical w/ Steel Reinf.	<b>HF-2516 -W1</b>		<b>1/2" Lock Washer</b> Zinc Plated Steel, For Attachment of Mid-Anchors (Wind Load / Dead Load)	<b>WS-5000</b>
	<b>1/4"-20 x 1" HWHMS Type CA</b> Stainless Steel For Attachment of Pressure Plate to Mullion	<b>HD-2516 -W3-SS</b>		<b>1/4" Lock Washer</b> Zinc Plated Steel For Attachment of "J" Anchor	<b>WS-2500</b>
	<b>1/4"-20 x 1-1/4" HWHMS</b> Zinc Plated Steel, For Attachment of 90° Outside Corner Adaptor to Vertical	<b>HM-2520 -W3</b>			







## FRAMING MEMBERS (1-1/2" GLAZING)

	<b>Horizontal</b> 2-1/2" x 3-3/4"	<b>BE9-3950</b>		<b>Flush Filler</b> Use With BE9-3904	<b>E9-3162</b>
	<b>Jamb / Mullion / Horizontal</b> 2-1/2" x 3-3/4"	<b>BE9-3949</b>		<b>Flush Filler</b> Use With BE9-3914	<b>E9-8489</b>
	<b>Horizontal</b> 2-1/2" x 5-1/4"	<b>BE9-3923</b>		<b>Standard Pressure Plate</b> E9-3906 with EPDM Isolator Drilled 9" O.C.	<b>AS-3906</b>
	<b>Head / Sill / Horizontal</b> 2-1/2" x 5-1/4"	<b>BE9-3924</b>		<b>Perimeter Pressure Plate</b> E9-3920 with PVC Isolator Punched 9" O.C.	<b>AS-3920</b>
	<b>Jamb / Mullion / Horizontal</b> 2-1/2" x 5-1/4"	<b>BE9-3922</b>		<b>Corner Adaptor</b>	<b>BE9-3931</b>
	<b>Head / Sill / Horizontal</b> 2-1/2" x 6-3/4"	<b>BE9-3932</b>		<b>3/4" x 3/4" x 1/8" Angle</b> Used at 90° Outside Corner	<b>E9-9307</b>
	<b>Jamb / Mullion / Horizontal</b> 2-1/2" x 6-3/4"	<b>BE9-3933</b>		<b>Face Cover</b> 2-1/2" x 3/4"	<b>E9-1206</b>
	<b>Outside Corner Mullion</b> 2-1/2" x 3-3/4"	<b>E9-1250</b>		<b>90° Outside Corner Interior Cover Base</b> Use with E9-1281	<b>E9-1280</b>
	<b>Outside Corner Mullion</b> 2-1/2" x 5-1/4"	<b>E9-1246</b>		<b>90° Outside Corner Interior Cover</b> For 5-1/4" Back Depth Only	<b>E9-1281</b>
	<b>Outside Corner Mullion</b> 2-1/2" x 8-1/4"	<b>E9-8121</b>		<b>90° Outside Corner Interior Cover Base</b> Use with E9-7762	<b>E9-3556</b>
	<b>Sill Flashing</b>	<b>BE9-3918</b>		<b>90° Outside Corner Interior Cover</b> For 3-3/4" & 8-1/4" Back Depth Only	<b>E9-7762</b>
	<b>Flush Filler</b> Use With BE9-3948	<b>E9-3595</b>		<b>Single Acting Transom Bar</b> For 35XT/50XT Doors** Elastomer Weathering E2-0051 Not Included	<b>BE9-1532</b>

\* Splay mullions and other face covers are available, contact YKK AP.











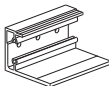
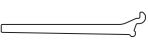

\*\* Note: 35XT/50XT Doors to be discontinued after April 30, 2024.

## FRAMING MEMBERS (1-1/2" GLAZING)

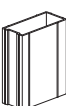

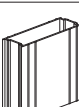











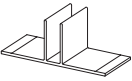

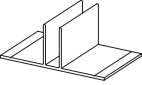

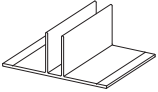

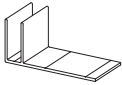

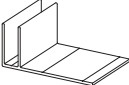

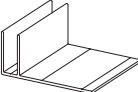
	<b>Door Jamb</b> For 35XT/50XT Doors** Use with BE9-1533	<b>BE9-1540</b>		<b>Door Jamb Flat Subframe</b> For 25T/35T/50T Doors Use with AS-1539	<b>BE9-1526</b>
	<b>Glazing Adaptor</b> For 1/4" Glazing	<b>E9-3936</b>		<b>Door Stop</b> For 25T/35T/50T Doors E2-0051 Included Use with BE9-1527	<b>AS-1539</b>
	<b>Door Stop</b> For 35XT/50XT Doors** E2-0051 Not Included Use with BE9-1540	<b>BE9-1533</b>		<b>Glazing Pocket Flush Filler</b>	<b>E9-3934</b>
	<b>Single Acting Transom Bar</b> For 25T/35T/50T Doors Elastomer Weathering E2-0051 not Included	<b>BE9-2582</b>			

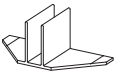
\*\* Note: 35XT/50XT Doors to be discontinued after April 30, 2024.

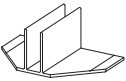

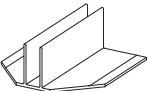
## ACCESSORIES (1-1/2" GLAZING)

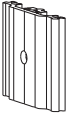
	<b>"J" Anchor</b> For 3-3/4" Depth Members Use (2) FC-1220 & Req. Fasteners	<b>E1-3501</b>		<b>90° Outside Corner Shear Block</b> For 6-3/4" Depth Members, Use (2) HF-2510-W1 & (2) FC-1212	<b>E1-3506A</b>
	<b>"J" Anchor</b> For 5-1/4" Depth Members Use (2) FC-1220 & Req. Fasteners	<b>E1-3502</b>		<b>Setting Block Chair</b>	<b>E1-3604</b>
	<b>Standard Shear Block</b> For 3-3/4" Depth Members Use (2) HF-2510-W1 & (2) FC-1220	<b>E1-3503</b>		<b>Mullion Joint Sleeve</b> For BE9-3949	<b>E1-1211</b>
	<b>Standard Shear Block</b> For 5-1/4" Depth Members Use (2) HF-2510-W1 & (2) FC-1220	<b>E1-3504</b>		<b>Mullion Joint Sleeve</b> For BE9-3922	<b>E1-1210</b>
	<b>Standard Shear Block</b> For 6-3/4" Depth Members Use (2) HF-2510-W1 & (2) FC-1220	<b>E1-3506</b>		<b>Mullion Joint Sleeve</b> For BE9-3933	<b>E1-1365</b>
	<b>90° Outside Corner Shear Block</b> For 5-1/4" Depth Members, Use (2) HF-2510-W1 & (2) FC-1212	<b>E1-3503A</b>		<b>Face Cover Splice Sleeve</b> For E9-1206 Face Cover	<b>E1-1202</b>
	<b>90° Outside Corner Shear Block</b> For 5-1/4" Depth Members, Use (2) HF-2510-W1 & (2) FC-1212	<b>E1-3504A</b>		<b>Standard Mullion End Cap</b> 2-1/2" x 2-7/8" x 0.050"	<b>E1-3606</b>







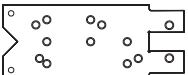



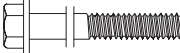

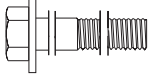

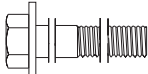

## ACCESSORIES (1-1/2" GLAZING)

	<b>Sill Flashing End Dam</b> 2.157" x 1-3/8" x 0.050"	<b>E1-3611</b>		<b>Setting Block</b> For 1-1/2" Glazing	<b>E2-3601</b>
	<b>Corner Mullion End Cap</b>	<b>E1-3609</b>		<b>Setting Block</b> For 1/4" Glazing	<b>E2-0192</b>
	<b>Intermediate Vertical "T" End Anchor*</b> For BE9-3949	<b>E1-1223</b>		<b>Side Block</b> With pressure sensitive adhesive	<b>E2-0133</b>
	<b>Intermediate Vertical "T" End Anchor*</b> For BE9-3922	<b>E1-1222</b>		<b>Standard Joint Plug</b> For 1-1/2" Glazing	<b>E2-3604</b>
	<b>Intermediate Vertical "T" End Anchor*</b> For BE9-3933	<b>E1-3601</b>		<b>Structural Tape</b>	<b>E2-0679</b>
	<b>Jamb "F" End Anchor*</b> For BE9-3949	<b>E1-1235</b>		<b>Nylon Slip Pad</b> For Wind Load & Dead Load Anchor	<b>E3-0103</b>
	<b>Jamb "F" End Anchor*</b> For BE9-3922	<b>E1-1234</b>		<b>Wind Load Anchor*</b> Refer to Shop Drawings For Anchor Dimensions	<b>E1-1204</b>
	<b>Jamb "F" End Anchor*</b> For BE9-3933	<b>E1-3602</b>		<b>Dead Load Anchor*</b> Refer to Shop Drawings For Anchor Dimensions	<b>E1-1205</b>
	<b>Corner "T" End Anchor</b> For 3-3/4" Depth Members	<b>E1-1207A</b>		<b>Interior/Exterior Glazing Gasket</b>	<b>E2-0120</b>
	<b>Corner "T" End Anchor</b> For 5-1/4" Depth Members	<b>E1-1209A</b>		<b>Sill Flashing Gasket</b>	<b>E2-0241</b>
	<b>Corner "T" End Anchor</b> For 8-1/4" Depth Members	<b>E1-3571A</b>		<b>Corner Condition Gasket</b>	<b>E2-0354</b>
	<b>Temporary Glass Retainer</b> 2" Long	<b>E1-3612</b>		<b>Elastomer Weathering</b> Used with BE9-1532 & BE9-1533	<b>E2-0051</b>

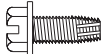



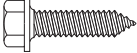

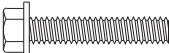



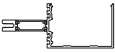

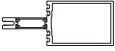



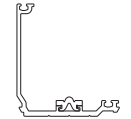
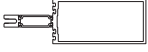
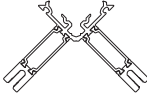



## ACCESSORIES (1-1/2" GLAZING)

	<b>Steel Reinforcing</b> 2" x 4" x 1/4" Steel Tube For BE9-3901 & BE9-3916	<b>E1-0162</b>		<b>Jamb Anchor Plate</b> 3" x 6" x 5/16" Thk.	<b>E1-3536</b>
	<b>Steel Reinforcing</b> 2" x 4" x 1/4" Steel Tube & (2) 1/4" x 1-3/4" Steel Bars For BE9-3901 & BE9-3916	<b>E1-0154</b>		<b>Drill Fixture</b>	<b>H-7210</b>

## FASTENERS (1-1/2" GLAZING)







	<b>#12 x 3/4" FHSMS Type</b> <b>AB</b> Zinc Plated Steel For Attachment of Horizontal to Corner Shear Block	<b>FC-1212</b>		<b>1/4"-20 x 3-1/2" HWHMS</b> Zinc Plated Steel For Attachment of "J" Anchor at Intermediate Vertical	<b>HM-2556</b> <b>-W3</b>
	<b>#12 x 1-1/4" FHSMS Type</b> <b>AB</b> Zinc Plated Steel For Attachment of Horizontal to Shear Block	<b>FC-1220</b>		<b>1/2"-13 x 2" HWHMS</b> Zinc Plated Steel, For Attachment of Windload/ Deadload Anchor at Jamb	<b>HM-5032</b>
	<b>#14 x 5/8" FHSMS Type</b> <b>AB</b> Zinc Plated Steel For Attachment of Mullion End Caps	<b>FC-1410</b>		<b>1/2"-13 x 4-1/2" HWHMS</b> Zinc Plated Steel, For Attachment of Windload/ Deadload Anchor at Mullion	<b>HM-5072</b>
	<b>#8 x 5/8" PHSMS Type AB</b> Zinc Plated Steel For Attachment of Glazing Adaptor E9-1220	<b>PC-0810</b>		<b>1/2"-13 Nut HHMS</b> Zinc Plated Steel For Attachment of Mid-Anchors (Wind Load / Dead Load)	<b>HM-5000</b>
	<b>#10 x 5/8" PHSMS Type</b> <b>AB</b> Zinc Plated Steel For Attachment of Sill Flashing BE9-3918	<b>PC-1010</b>		<b>1/4"-20 Nut HHMS</b> Zinc Plated Steel For Attachment of "J" Anchor	<b>HM-2500</b>
	<b>#8 x 1/2" PHSMS Type F</b> Stainless Steel, For Attachment of Splice Sleeve Face Covers	<b>PF-0808</b> <b>-SS</b>		<b>1/4" Flat Washer</b> Zinc Plated Steel For Attachment of "J" Anchor	<b>WW-2500</b>
	<b>1/4"-20 x 5/8" HWHS Type</b> <b>F</b> Zinc Plated Steel For Attachment of Standard Shear Block to Vertical	<b>HF-2510</b> <b>-W1</b>		<b>1/2" Flat Washer</b> Zinc Plated Steel, For Attachment of Mid-Anchors (Wind Load / Dead Load)	<b>WW-5000</b>
	<b>1/4"-20 x 1" HWHS Type</b> <b>F</b> , Zinc Plated Steel, For Attachment of Standard Shear Block to Vertical w/ Steel Reinf.	<b>HF-2516</b> <b>-W1</b>		<b>1/2" Lock Washer</b> Zinc Plated Steel, For Attachment of Mid-Anchors (Wind Load / Dead Load)	<b>WS-5000</b>
	<b>1/4"-20 x 1" HWHMS Type</b> <b>CA</b> Stainless Steel For Attachment of Pressure Plate to Mullion	<b>HD-2516</b> <b>-W3-SS</b>		<b>1/4" Lock Washer</b> Zinc Plated Steel For Attachment of "J" Anchor	<b>WS-2500</b>
	<b>1/4"-20 x 1-1/4" HWHMS</b> Zinc Plated Steel, For Attachment of 90° Outside Corner Adaptor to Vertical	<b>HM-2520</b> <b>-W3</b>			

## FRAMING MEMBERS (2" GLAZING)

	<b>Horizontal</b> 2-1/2" x 3-3/4"	<b>BE9-3944</b>		<b>Flush Filler</b> Use With BE9-3927	<b>E9-3162</b>
	<b>Jamb / Mullion / Horizontal</b> 2-1/2" x 3-3/4"	<b>BE9-3943</b>		<b>Flush Filler</b> Use With BE9-3929	<b>E9-8489</b>
	<b>Horizontal</b> 2-1/2" x 5-1/4"	<b>BE9-3926</b>		<b>Standard Pressure Plate</b> E9-3906 with EPDM Isolator Drilled 9" O.C.	<b>AS-3906</b>
	<b>Head / Sill / Horizontal</b> 2-1/2" x 5-1/4"	<b>BE9-3927</b>		<b>Perimeter Pressure Plate</b> E9-3921 with EPDM Isolator Drilled 9" O.C.	<b>AS-3921</b>
	<b>Jamb / Mullion / Horizontal</b> 2-1/2" x 5-1/4"	<b>BE9-3925</b>		<b>Corner Adaptor</b>	<b>BE9-3930</b>
	<b>Head / Sill / Horizontal</b> 2-1/2" x 6-3/4"	<b>BE9-3929</b>		<b>3/4" x 3/4" x 1/8" Angle</b> Used at 90° Outside Corner	<b>E9-9307</b>
	<b>Jamb / Mullion / Horizontal</b> 2-1/2" x 6-3/4"	<b>BE9-3928</b>		<b>Face Cover</b> 2-1/2" x 3/4"	<b>E9-1206</b>
	<b>Outside Corner Mullion</b> 2-1/2" x 3-3/4"	<b>E9-1250</b>		<b>90° Outside Corner Interior Cover Base</b> Use with E9-1281	<b>E9-1280</b>
	<b>Outside Corner Mullion</b> 2-1/2" x 5-1/4"	<b>E9-1246</b>		<b>90° Outside Corner Interior Cover</b> For 5-1/4" Back Depth Only	<b>E9-1281</b>
	<b>Outside Corner Mullion</b> 2-1/2" x 8-1/4"	<b>E9-8121</b>		<b>90° Outside Corner Interior Cover Base</b> Use with E9-7762	<b>E9-3556</b>
	<b>Sill Flashing</b>	<b>BE9-3918</b>		<b>90° Outside Corner Interior Cover</b> For 8-1/4" Back Depth Only	<b>E9-7762</b>
	<b>Flush Filler</b> Use With BE9-3948	<b>E9-3595</b>		<b>Single Acting Transom Bar</b> For 35XT/50XT Doors** Elastomer Weathering E2-0051 Not Included	<b>BE9-1532</b>









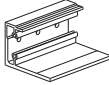

\* Splay mullions and other face covers are available, contact YKK AP.

## FRAMING MEMBERS (2" GLAZING)





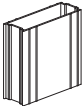
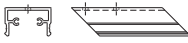

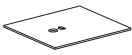



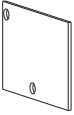



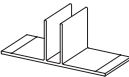
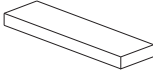
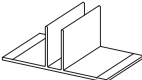
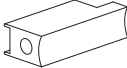
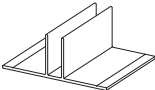

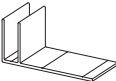

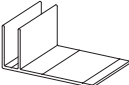

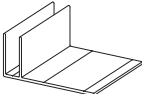
	<b>Door Jamb</b> For 35XT/50XT Doors** Use with BE9-1533	<b>BE9-1540</b>		<b>Door Jamb Flat Subframe</b> For 25T/35T/50T Doors Use with AS-1539	<b>BE9-1526</b>
	<b>Glazing Adaptor</b> For 1/4" Glazing	<b>E9-3937</b>		<b>Door Stop</b> For 25T/35T/50T Doors E2-0051 Included Use with BE9-1527	<b>AS-1539</b>
	<b>Door Stop</b> For 35XT/50XT Doors** E2-0051 Not Included Use with BE9-1540	<b>BE9-1533</b>		<b>Glazing Pocket Flush Filler</b>	<b>E9-3935</b>
	<b>Single Acting Transom Bar</b> For 25T/35T/50T Doors Elastomer Weathering E2-0051 not Included	<b>BE9-2582</b>			

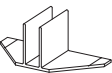
\*\* Note: 35XT/50XT Doors to be discontinued after April 30, 2024.

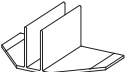
## ACCESSORIES (2" GLAZING)

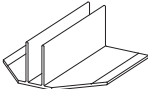
	<b>"J" Anchor</b> For 3-3/4" Depth Members Use (2) FC-1220 & Req. Fasteners	<b>E1-3501</b>		<b>90° Outside Corner Shear Block</b> For 6-3/4" Depth Members, Use (2) HF-2510-W1 & (2) FC-1212	<b>E1-3506A</b>
	<b>"J" Anchor</b> For 5-1/4" Depth Members Use (2) FC-1220 & Req. Fasteners	<b>E1-3502</b>		<b>Setting Block Chair</b>	<b>E1-3604</b>
	<b>Standard Shear Block</b> For 3-3/4" Depth Members Use (2) HF-2510-W1 & (2) FC-1220	<b>E1-3503</b>		<b>Mullion Joint Sleeve</b> For BE9-3943	<b>E1-1211</b>
	<b>Standard Shear Block</b> For 5-1/4" Depth Members Use (2) HF-2510-W1 & (2) FC-1220	<b>E1-3504</b>		<b>Mullion Joint Sleeve</b> For BE9-3925	<b>E1-1210</b>
	<b>Standard Shear Block</b> For 6-3/4" Depth Members Use (2) HF-2510-W1 & (2) FC-1220	<b>E1-3506</b>		<b>Mullion Joint Sleeve</b> For BE9-3928	<b>E1-1365</b>
	<b>90° Outside Corner Shear Block</b> For 5-1/4" Depth Members, Use (2) HF-2510-W1 & (2) FC-1212	<b>E1-3503A</b>		<b>Face Cover Splice Sleeve</b> For E9-1206 Face Cover	<b>E1-1202</b>
	<b>90° Outside Corner Shear Block</b> For 5-1/4" Depth Members, Use (2) HF-2510-W1 & (2) FC-1212	<b>E1-3504A</b>		<b>Standard Mullion End Cap</b> 2-1/2" x 3-3/8" x 0.050"	<b>E1-3607</b>

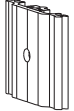
## ACCESSORIES (2" GLAZING)

	<b>Sill Flashing End Dam</b> 2.157" x 1-3/8" x 0.050"	<b>E1-3611</b>		<b>Setting Block</b> For 2" Glazing	<b>E2-3602</b>
	<b>Corner Mullion End Cap</b>	<b>E1-3610</b>		<b>Setting Block</b> For 1/4" Glazing	<b>E2-0192</b>
	<b>Intermediate Vertical "T" End Anchor*</b> For BE9-3943	<b>E1-1223</b>		<b>Side Block</b> With pressure sensitive adhesive	<b>E2-0133</b>
	<b>Intermediate Vertical "T" End Anchor*</b> For BE9-3925	<b>E1-1222</b>		<b>Standard Joint Plug</b> For 2" Glazing	<b>E2-3605</b>
	<b>Intermediate Vertical "T" End Anchor*</b> For BE9-3928	<b>E1-3601</b>		<b>Structural Tape</b>	<b>E2-0679</b>
	<b>Jamb "F" End Anchor*</b> For BE9-3943	<b>E1-1235</b>		<b>Nylon Slip Pad</b> For Wind Load & Dead Load Anchor	<b>E3-0103</b>
	<b>Jamb "F" End Anchor*</b> For BE9-3925	<b>E1-1234</b>		<b>Wind Load Anchor*</b> Refer to Shop Drawings For Anchor Dimensions	<b>E1-1204</b>
	<b>Jamb "F" End Anchor*</b> For BE9-3928	<b>E1-3602</b>		<b>Dead Load Anchor*</b> Refer to Shop Drawings For Anchor Dimensions	<b>E1-1205</b>
	<b>Corner "T" End Anchor</b> For 3-3/4" Depth Members	<b>E1-1207A</b>		<b>Interior/Exterior Glazing Gasket</b>	<b>E2-0120</b>
	<b>Corner "T" End Anchor</b> For 5-1/4" Depth Members	<b>E1-1209A</b>		<b>Sill Flashing Gasket</b>	<b>E2-0241</b>
	<b>Corner "T" End Anchor</b> For 8-1/4" Depth Members	<b>E1-3571A</b>		<b>Corner Condition Gasket</b>	<b>E2-0354</b>
	<b>Temporary Glass Retainer</b> 2" Long	<b>E1-3612</b>		<b>Elastomer Weathering</b> Used with BE9-1532 & BE9-1533	<b>E2-0051</b>



## ACCESSORIES (2" GLAZING)

	<b>Steel Reinforcing</b> 2" x 4" x 1/4" Steel Tube For BE9-3901 & BE9-3916	<b>E1-0162</b>		<b>Jamb Anchor Plate</b> 3" x 6" x 5/16" Thk.	<b>E1-3536</b>
	<b>Steel Reinforcing</b> 2" x 4" x 1/4" Steel Tube & (2) 1/4" x 1-3/4" Steel Bars For BE9-3901 & BE9-3916	<b>E1-0154</b>		<b>Drill Fixture</b>	<b>H-7210</b>

## FASTENERS (2" GLAZING)

	<b>#12 x 3/4" FHSMS Type</b> <b>AB</b> Zinc Plated Steel For Attachment of Horizontal to Corner Shear Block	<b>FC-1212</b>		<b>1/4"-20 x 3-1/2" HWHMS</b> Zinc Plated Steel For Attachment of "J" Anchor at Intermediate Vertical	<b>HM-2556</b> <b>-W3</b>
	<b>#12 x 1-1/4" FHSMS Type</b> <b>AB</b> Zinc Plated Steel For Attachment of Horizontal to Shear Block	<b>FC-1220</b>		<b>1/2"-13 x 2" HWHMS</b> Zinc Plated Steel, For Attachment of Windload/ Deadload Anchor at Jamb	<b>HM-5032</b>
	<b>#14 x 5/8" FHSMS Type</b> <b>AB</b> Zinc Plated Steel For Attachment of Mullion End Caps	<b>FC-1410</b>		<b>1/2"-13 x 4-1/2" HWHMS</b> Zinc Plated Steel, For Attachment of Windload/ Deadload Anchor at Mullion	<b>HM-5072</b>
	<b>#8 x 5/8" PHSMS Type AB</b> Zinc Plated Steel For Attachment of Glazing Adaptor E9-1220	<b>PC-0810</b>		<b>1/2"-13 Nut HHMS</b> Zinc Plated Steel For Attachment of Mid-Anchors (Wind Load / Dead Load)	<b>HM-5000</b>
	<b>#10 x 5/8" PHSMS Type</b> <b>AB</b> Zinc Plated Steel For Attachment of Sill Flashing BE9-3918	<b>PC-1010</b>		<b>1/4"-20 Nut HHMS</b> Zinc Plated Steel For Attachment of "J" Anchor	<b>HM-2500</b>
	<b>#8 x 1/2" PHSMS Type F</b> Stainless Steel, For Attachment of Splice Sleeve Face Covers	<b>PF-0808</b> <b>-SS</b>		<b>1/4" Flat Washer</b> Zinc Plated Steel For Attachment of "J" Anchor	<b>WW-2500</b>
	<b>1/4"-20 x 5/8" HWHS Type</b> <b>F</b> Zinc Plated Steel For Attachment of Standard Shear Block to Vertical	<b>HF-2510</b> <b>-W1</b>		<b>1/2" Flat Washer</b> Zinc Plated Steel, For Attachment of Mid-Anchors (Wind Load / Dead Load)	<b>WW-5000</b>
	<b>1/4"-20 x 1" HWHS Type</b> <b>F</b> , Zinc Plated Steel, For Attachment of Standard Shear Block to Vertical w/ Steel Reinf.	<b>HF-2516</b> <b>-W1</b>		<b>1/2" Lock Washer</b> Zinc Plated Steel, For Attachment of Mid-Anchors (Wind Load / Dead Load)	<b>WS-5000</b>
	<b>1/4"-20 x 1" HWHMS Type</b> <b>CA</b> Stainless Steel For Attachment of Pressure Plate to Mullion	<b>HD-2516</b> <b>-W3-SS</b>		<b>1/4" Lock Washer</b> Zinc Plated Steel For Attachment of "J" Anchor	<b>WS-2500</b>
	<b>1/4"-20 x 1-1/4" HWHMS</b> Zinc Plated Steel, For Attachment of 90° Outside Corner Adaptor to Vertical	<b>HM-2520</b> <b>-W3</b>			

**VAPOR BARRIER****ATTACHING VAPOR BARRIER TO YCW 750 XT**

Vapor barriers can be installed to both mullions and horizontals by means of vapor barrier reglets, see image below. Please follow the vapor barrier manufacturer's installation instructions for correct installation of the vapor barrier.

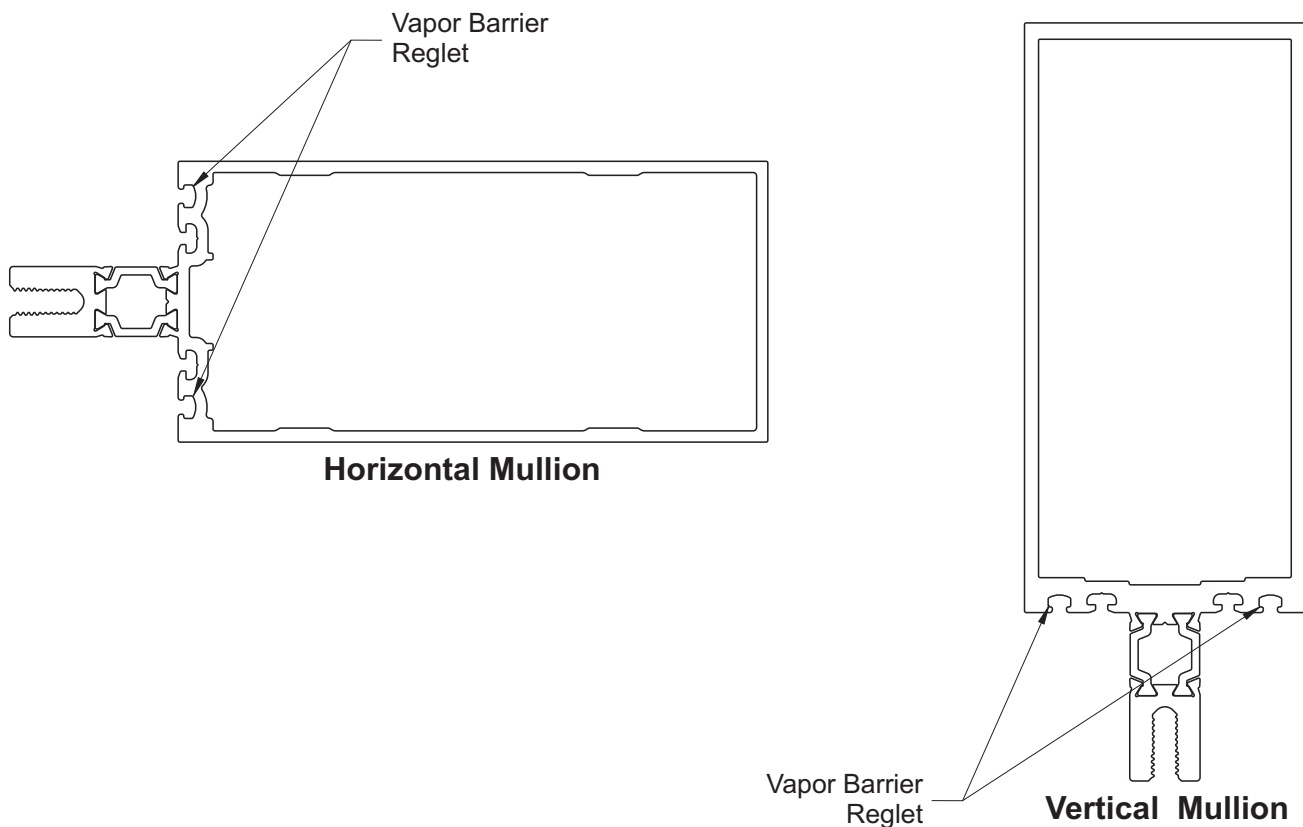

## FRAME FABRICATION

### FRAME TYPES / ANCHORING METHODS

The following is a guideline for common types of frames. Refer to shop drawings for exact layout of frames.

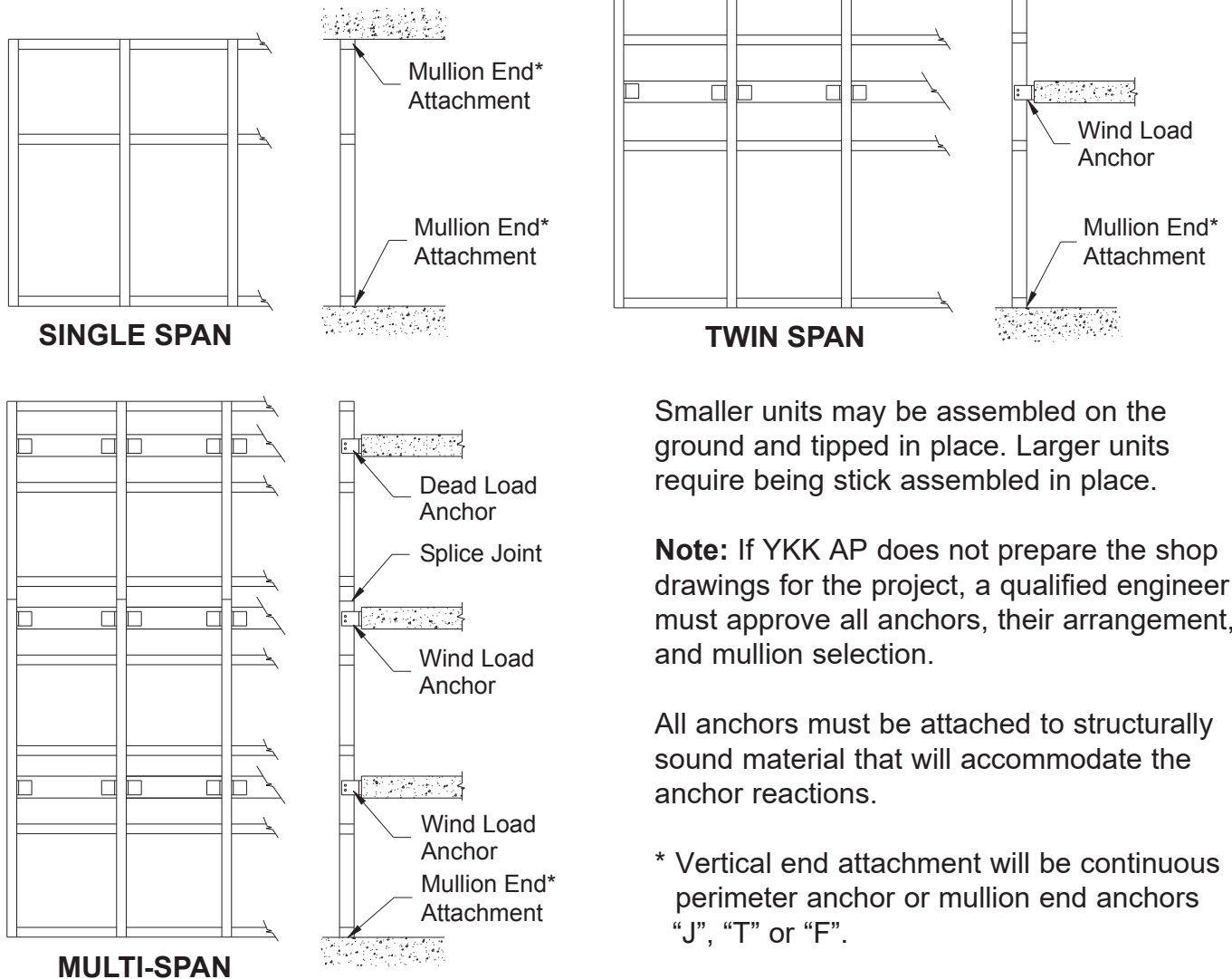

Smaller units may be assembled on the ground and tipped in place. Larger units require being stick assembled in place.

**Note:** If YKK AP does not prepare the shop drawings for the project, a qualified engineer must approve all anchors, their arrangement, and mullion selection.

All anchors must be attached to structurally sound material that will accommodate the anchor reactions.

\* Vertical end attachment will be continuous perimeter anchor or mullion end anchors "J", "T" or "F".

**Fabrication of YCW 750 XT varies depending on the type of mullion end attachment required for a given project:**

**Perimeter Anchors** are for low load anchoring conditions (maximum 500lb. end load reaction): E9-1248, E9-1223, & E9-1231 for 1" infill applications only.

**"J" Anchors** are for medium to high load conditions: E1-3501, E1-3502, & E1-3505.

**"T" & "F" Anchors** are for high load conditions: E1-1207, E1-1208, E1-1209, E1-1231, E1-1232, E1-1233, E1-1238, & E1-1240 (for 1" infill applications only).

## FRAME FABRICATION

### FRAME TYPES / ANCHORING METHODS

#### Using Perimeter Anchors:

-Mullions must be notched as shown in **Detail 1** on **Page-16**.

#### Using Mullion End Anchors:

YCW 750 XT has three possible end anchoring conditions: "J", "T", and "F".

- "J" anchors are used with jambs and intermediate mullions at the sill only.
- "T" anchors are used with intermediate mullions at the head and sill.
- "F" anchors are used with jamb mullions at the head and sill.
- "Door Jamb" anchors are used with mullions at a door jamb and are specified by the approved shop drawings or P.E. calcs.
- Anchor usage depends on end reaction, stress, and attachment.

Mullions should be pre-assembled with shear blocks/clips, end anchors, and steel or aluminum reinforcing if necessary. End anchors should be pre-drilled for anchor fasteners according to approved shop drawings or engineering calculations.

#### Framing Members for Stick Build:

- Open back head and sill members provide easy access to end anchor fasteners.
- Closed horizontal members are used at all intermediate locations except at end bays.
- Open back intermediate horizontals are used at end bays to clear the shear blocks.

**Note:** When using stick build construction, check overall frame width every fifth mullion as the wall is installed. A buildup of cumulative tolerance errors may occur, resulting in excessive DLO spacing.

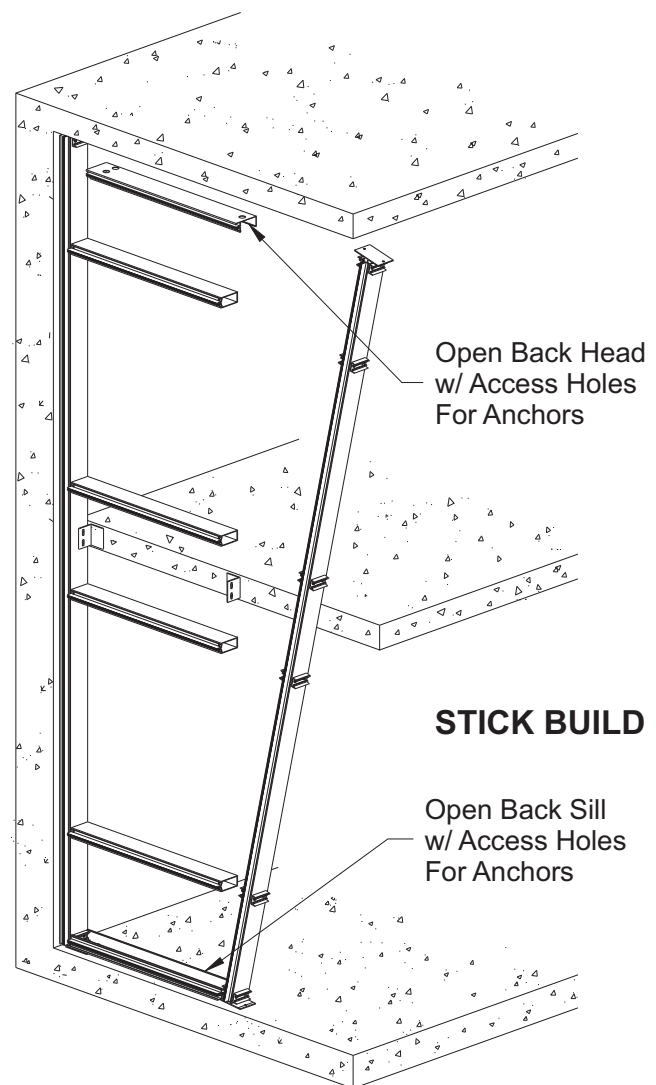

## FRAME FABRICATION

### FABRICATE MULLIONS

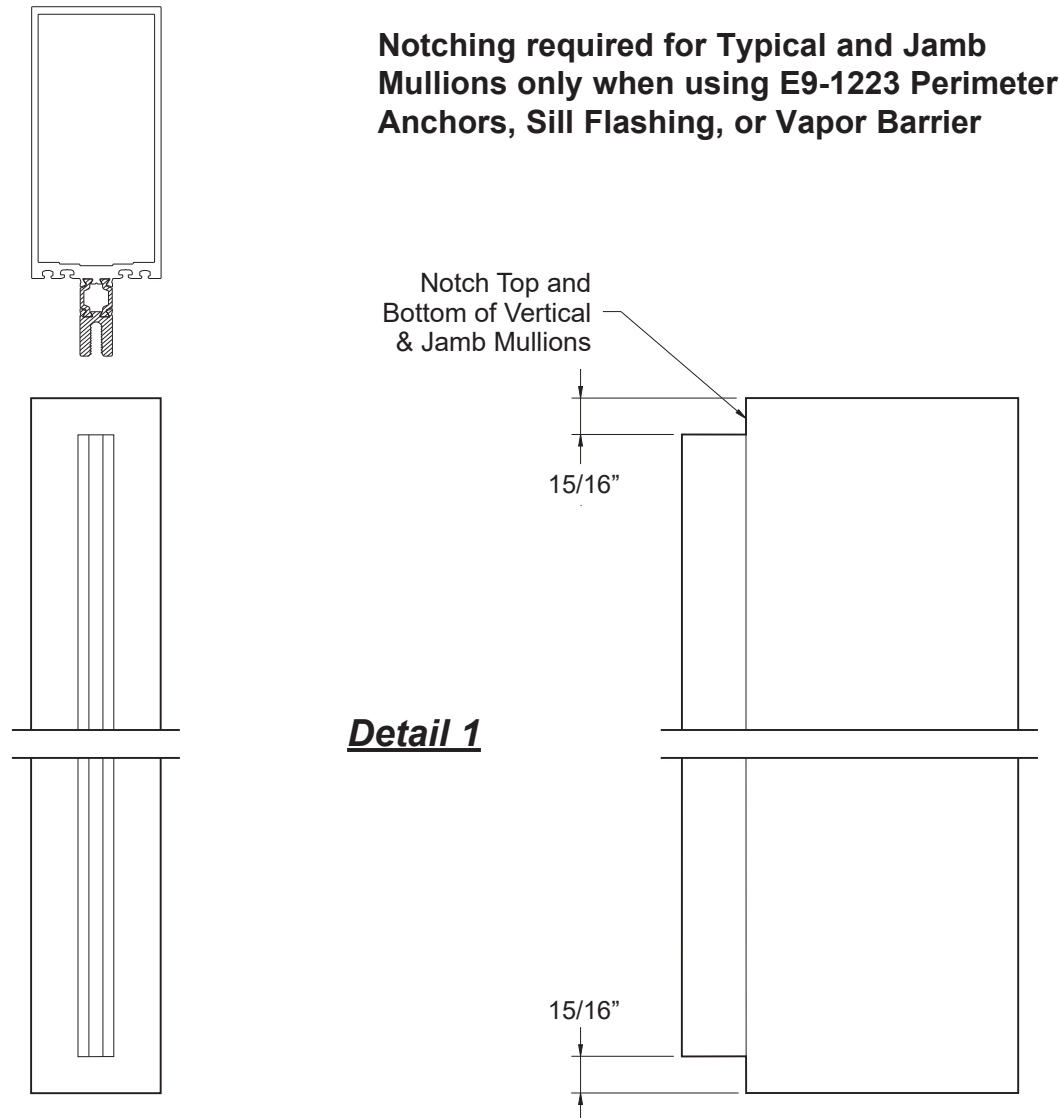

#### Step 1

-Cut all typical and jamb mullions members to dimensions as shown on shop drawings. Allow for 1/2" caulk joint around the frame & 1/2" joint at vertical splices.

**Note:** Mullions at door jambs are sealed against the substrate at the sill without a shim space at that location.

#### Step 2

-When using continuous perimeter anchor E9-1223, the top and bottom of the typical and jamb mullion members must be notched as shown in **Detail 1**.

## FRAME FABRICATION

### STEP 3 FABRICATE MULLIONS

- Mullion hole locations for shear blocks, shear clips, and "J" anchors are shown below.
  - Drill 0.213" dia. (#3 bit) holes for shear block/clip attachment at the locations indicated.
  - Drill 0.281" dia. (#9/32 bit) holes for "J" anchor attachment at the sill at the locations indicated.
- See **Detail 2**.

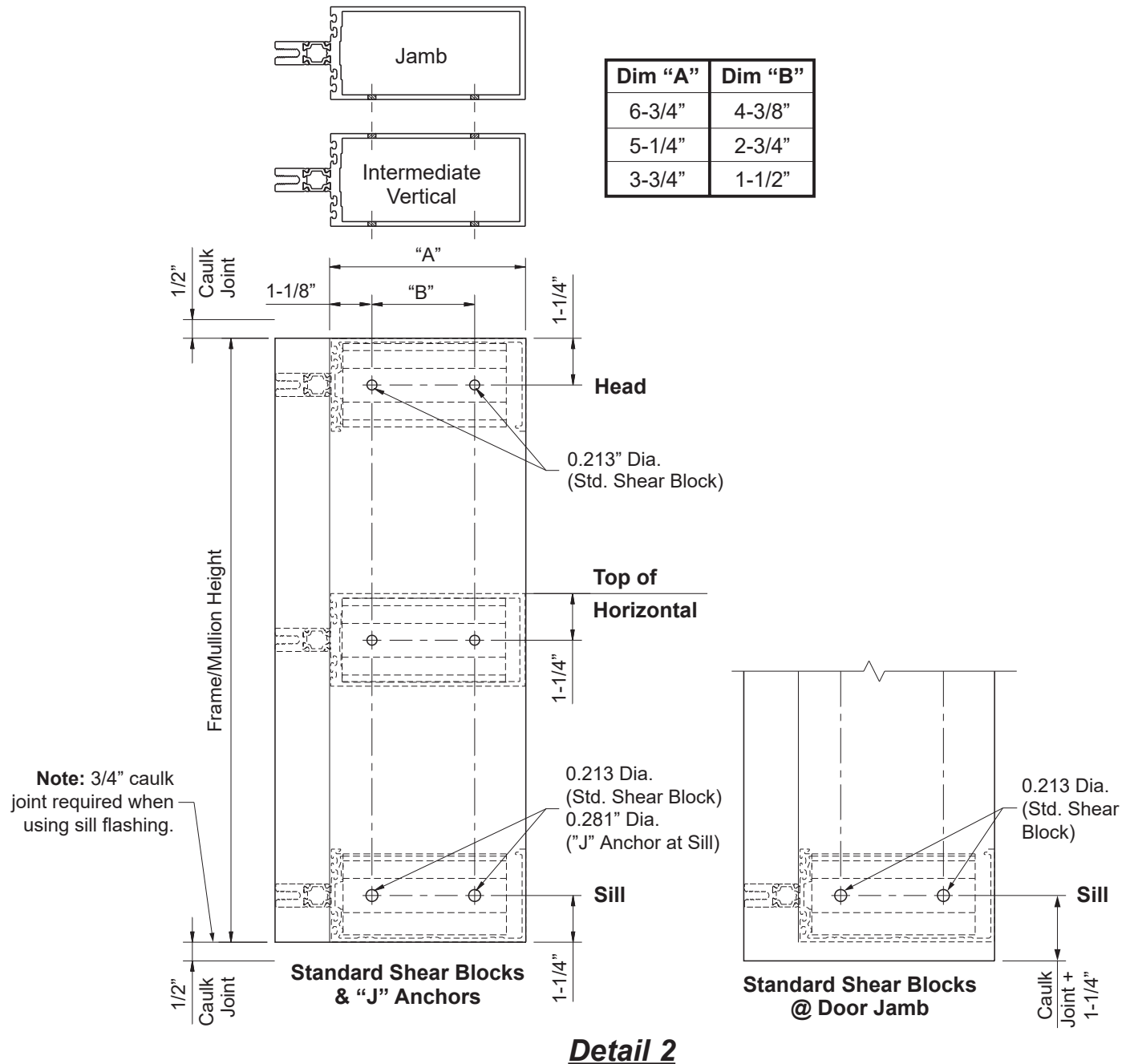

## FRAME FABRICATION

### STEP 3 (Continued)

### FABRICATE 90° OUTSIDE CORNER MULLIONS

- Mullion hole locations for shear blocks, shear clips, and “J” anchors are shown below.
  - Drill 0.213” dia. (#3 bit) holes for shear block/clip attachment at the locations indicated.
  - Drill 0.281” dia. (#9/32 bit) holes for “J” anchor attachment at the sill at the locations indicated.
- See **Detail 3**.

**Note:** Hole locations for standard shear blocks are not the same as shear clips for optional incidental water head.

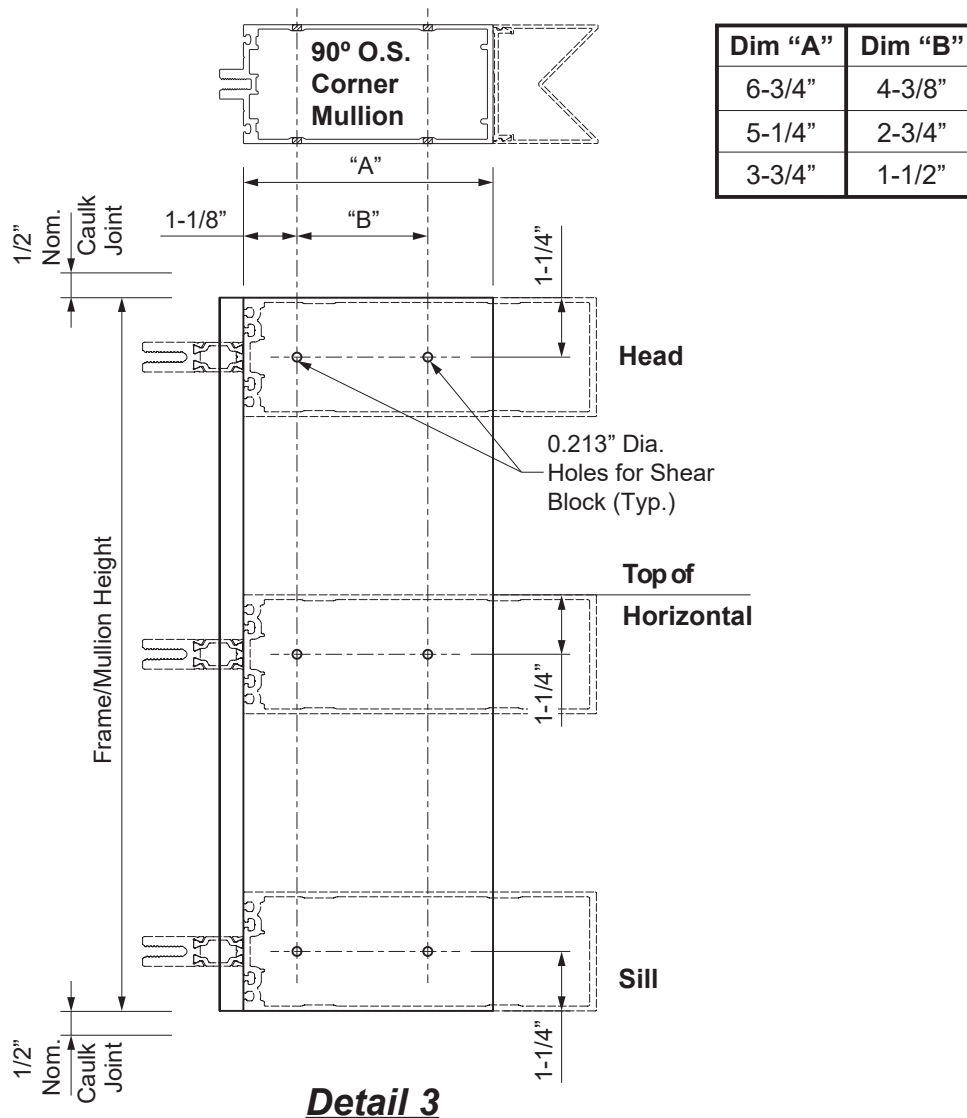

## FRAME FABRICATION

### STEP 4 (Optional) USING STEEL REINFORCING

When engineering calculations require the mullions to be reinforced with steel, secure the reinforcing to the mullion using the appropriate fasteners.

- Start 3" from both ends of the mullion and install a fastener on both sides of the mullion tongue.
- Stagger the fasteners on either side of the tongue going up the mullion.
- Seal all screw heads with sealant.

**Note:** Exact size of reinforcing, size and location of fasteners to be determined by a qualified engineer.

Steel reinforcing is also attached on the sides of the mullion with the attachment of shear blocks.

- Drill 0.281" dia. (9/32 bit) clear holes in the mullion only.
- Match drill 0.213 dia. (#3 bit) tap holes in the reinforcing only.
- Attach the shear blocks with HF-2516-W1 fasteners.

See **Detail 4**.

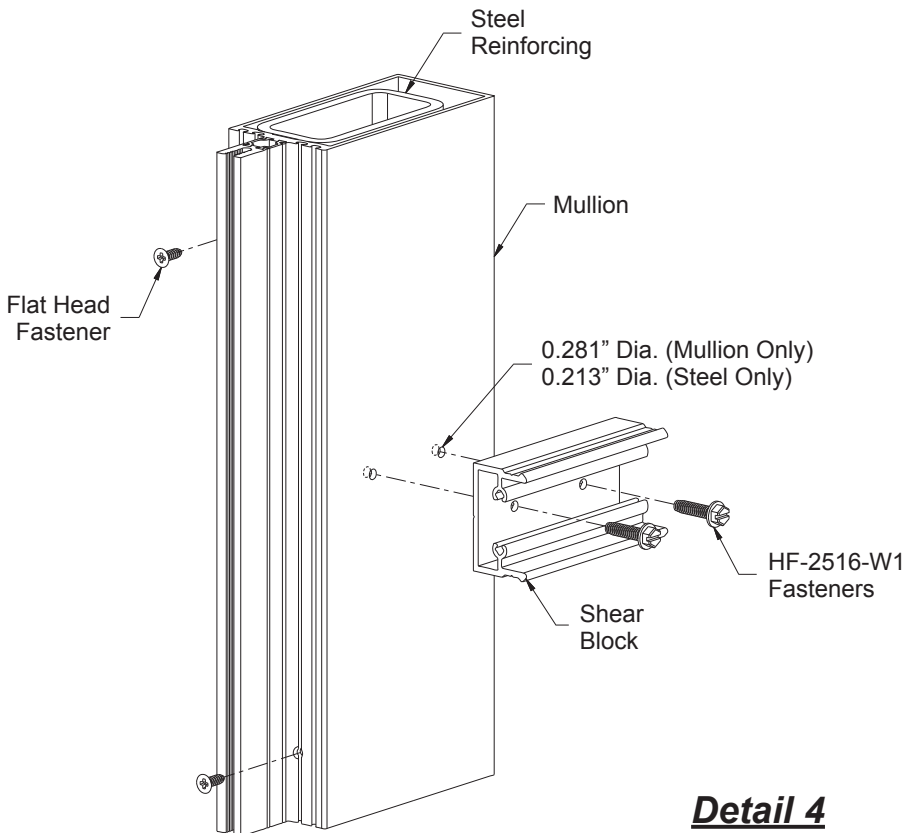

***Detail 4***

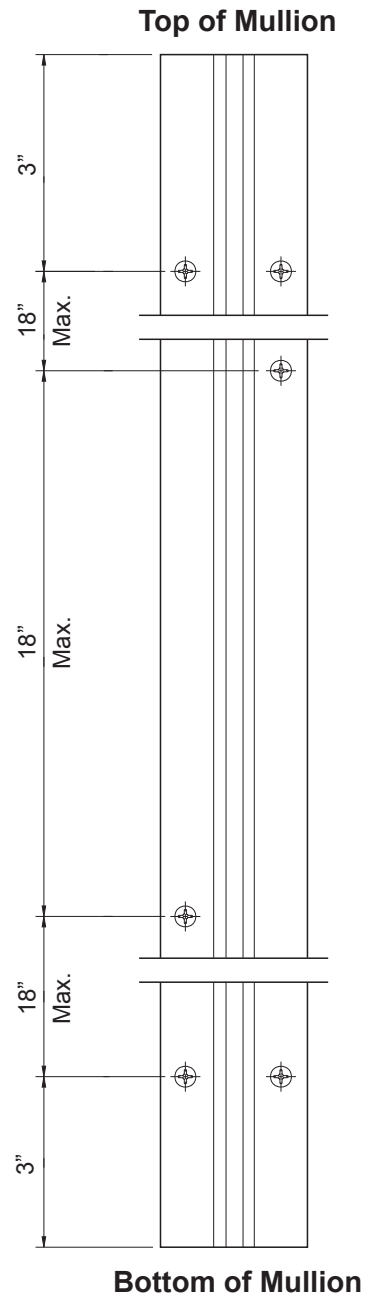



## FRAME FABRICATION

### STEP 5 ASSEMBLE 90° OUTSIDE CORNER MULLIONS

- Drill 0.281" diameter clear holes into the corner mullion adaptor at 1-1/2" from each end and at 9" maximum on center.
- Fasten the corner mullion adaptor onto the corner mullion using HM-2520-W3 screws. Tighten the screws to 70 inch-pounds.

- Prior to attaching the corner shear blocks to the corner mullion, the interior covers must be installed. Attach the interior cover base to the back of the corner mullion with PC-1010 screws at 24" maximum on center. Then snap on the interior cover.

See **Detail 5**.

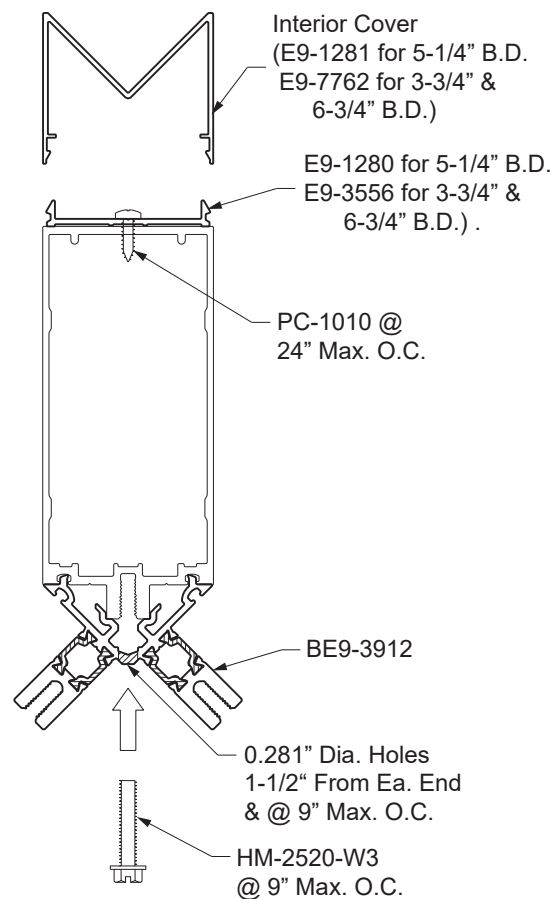

**Detail 5**

## FRAME FABRICATION

### STEP 5 ATTACH SHEAR BLOCKS/CLIPS FOR HORIZONTALS

Standard shear blocks are used to attach horizontal members to the jambs and mullions.

E1-3503 for 3-3/4" back members.

E1-3504 for 5-1/4" back members.

E1-3506 for 6-3/4" back members.

-Attach shear blocks to jambs and mullions with (2) HF-2510-W1 fasteners per block.

See **Detail 6**.

**Note:** Do not attach standard shear blocks at the head and sill for end bays at this time.  
See **Step 16** on **Page 43** for head and sill end bay attachment.

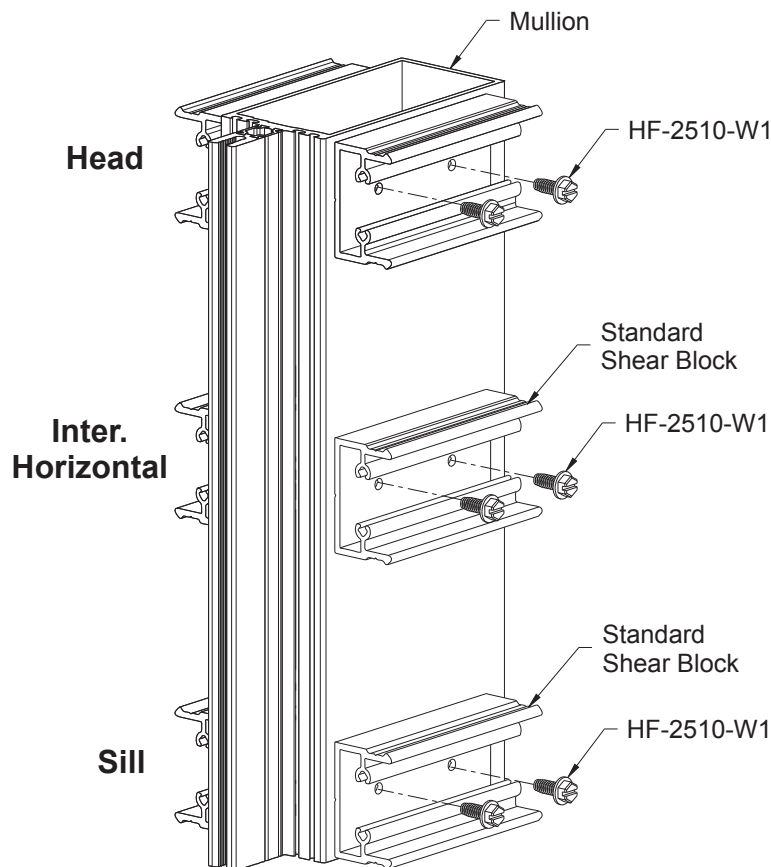

**Detail 6**

## FRAME FABRICATION

### STEP 5 ATTACH SHEAR BLOCKS/CLIPS FOR HORIZONTALS

Standard shear blocks are used to attach horizontal members to the jambs and mullions.

E1-3503A for 3-3/4" back members.

E1-3504A for 5-1/4" back members.

E1-3506A for 6-3/4" back members.

-Attach shear blocks to jambs and mullions with (2) HF-2510-W1 fasteners per block.

See **Detail 7**.

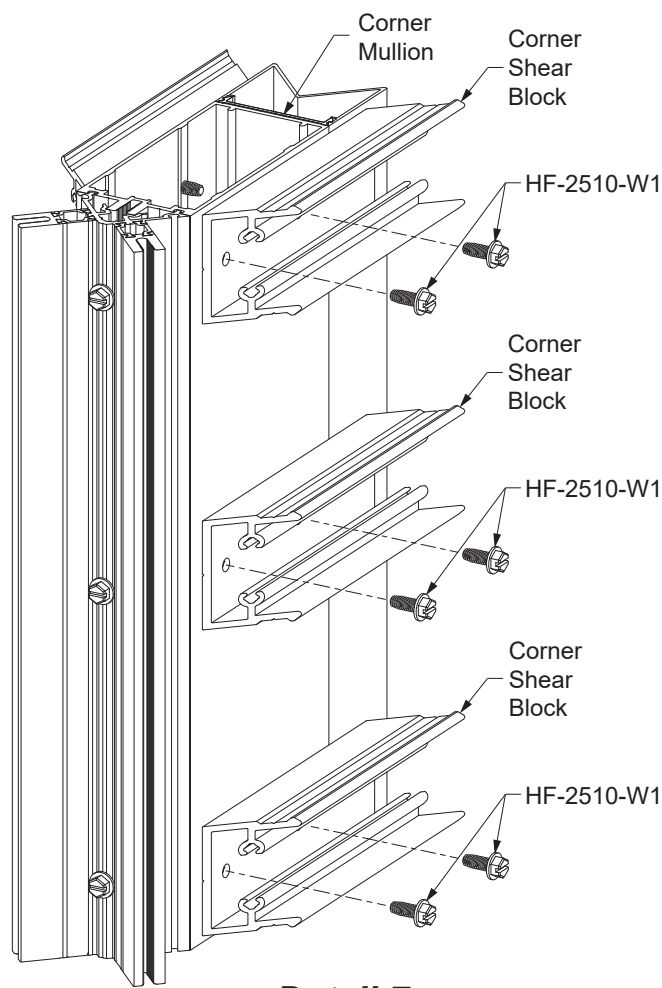

## FRAME FABRICATION

### STEP 6 ATTACH "J" ANCHORS

In addition to anchoring the curtain wall frame to the structure, "J" anchors are used to attach sill members to jamb and vertical mullions:

- E1-3501 for 3-3/4" back members.
- E1-3502 for 5-1/4" back members.
- E1-3505 for 6-3/4" back members.

**Note:** "J" anchors are used at the sill only.

#### Attach "J" Anchors at Jamb:

- Align the "J" anchor with the mullion and insert the HM-2516-W3 bolts through the inside of the mullion and out the "J" anchor.
- Install 1/4" flat and lock washers between the anchor and HM-2500 hex nuts.

#### Attach "J" Anchors at Intermediate Mullions:

- Align the "J" anchors and insert the HM-2556 bolts through both anchors and the mullion.
- Install 1/4" flat and lock washers between the anchor and HM-2500 hex nuts.

See **Detail 8**.

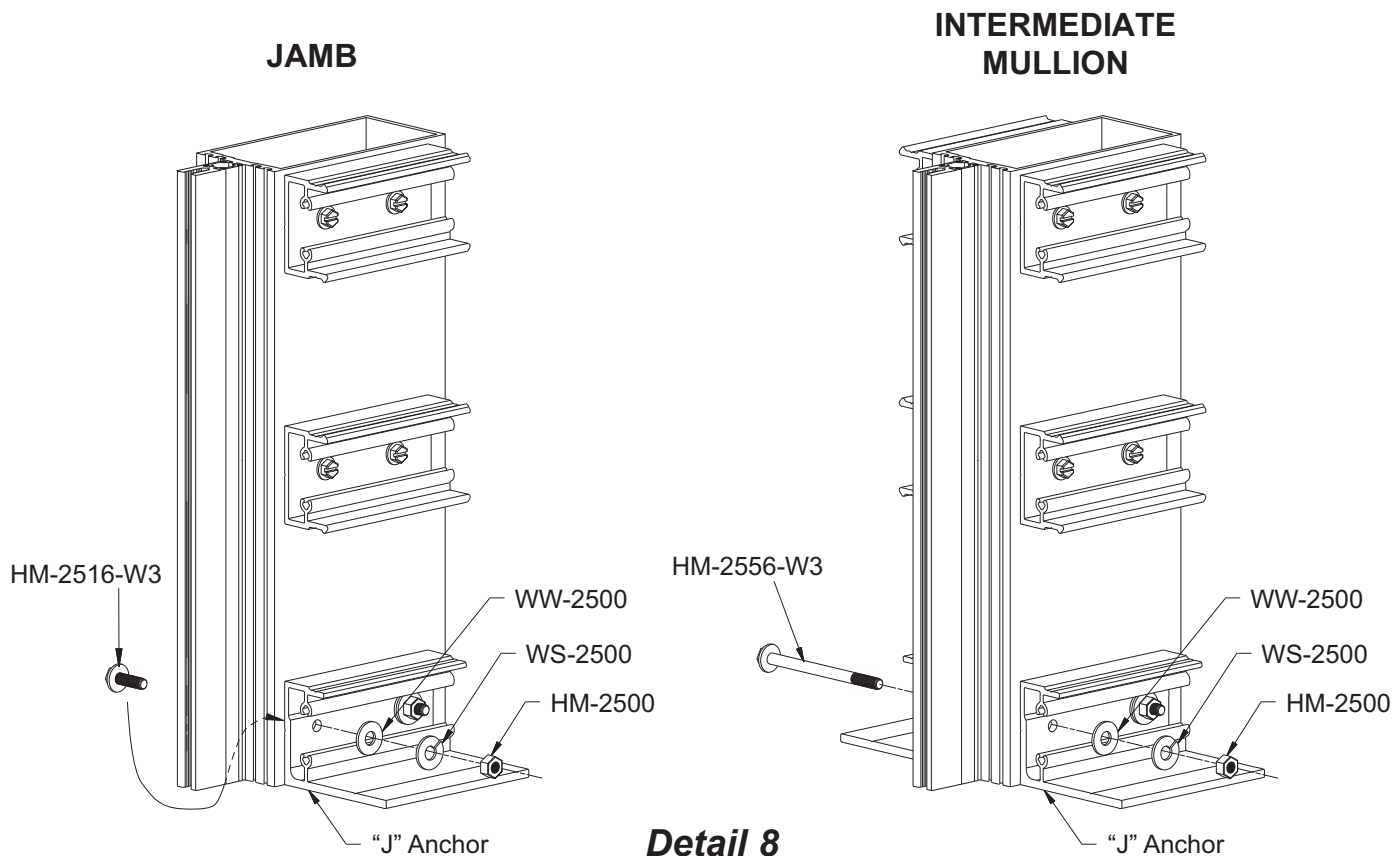

## FRAME FABRICATION

### STEP 7 FABRICATE HORIZONTAL MEMBERS

- Cut all horizontal members to the daylight opening as shown in shop drawings.
- Cut all horizontal flush fillers to the daylight opening minus(-) 1/32".
- Horizontal members must be fabricated for shear block/clip attachment as follows:

#### Horizontals with Concealed Fasteners:

- Layout hole locations on the face of the horizontal at both ends as shown below.
- Using drill fixture H-7210, drill 0.236" diameter (#B bit) holes and countersink for #12 flat head fasteners.

See **Detail 9**.

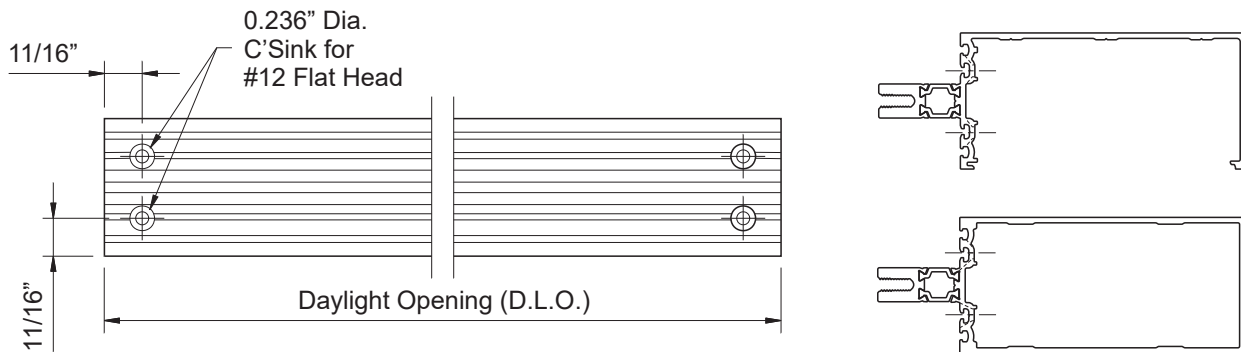

**Detail 9**

#### Horizontals with Exposed Fasteners:

- Layout hole locations on the top of the horizontal at both ends as shown below.
- Drill 0.236" diameter (#B bit) holes and countersink for #12 flat head fasteners.

See **Detail 10**.

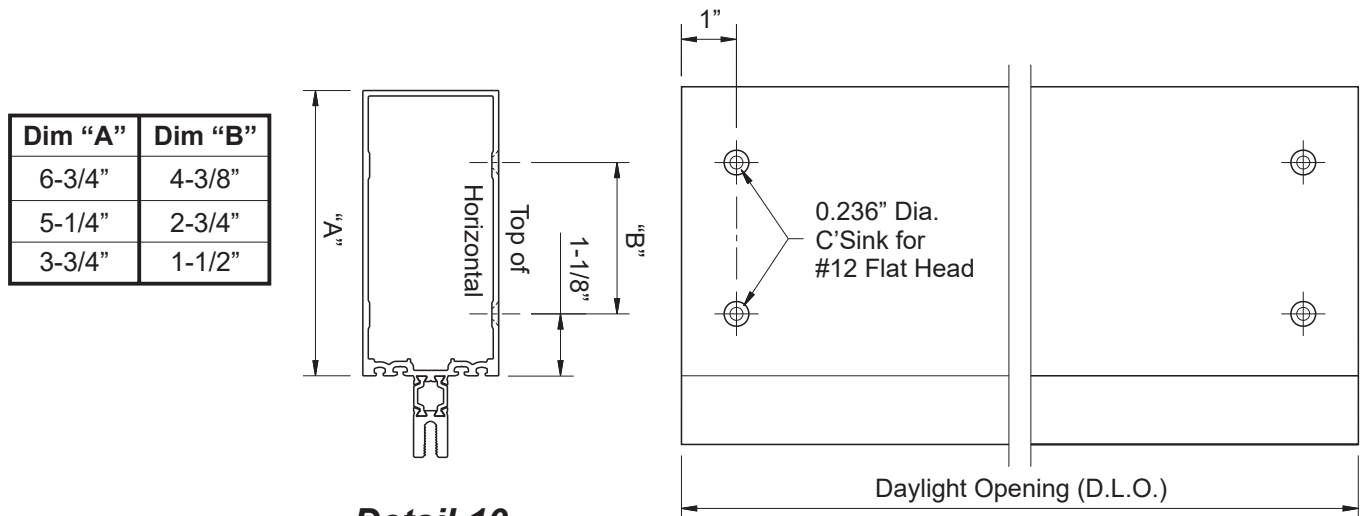

**Detail 10**

## FRAME FABRICATION

### STEP 7 (Continued)

### FABRICATE HORIZONTAL MEMBERS @ 90° OUTSIDE CORNER

**Note:** Tubular head and sill members must be used at 90° corner mullion. Intermediate horizontals can be either tubular or open back.

-Layout hole locations from the face of the tubular horizontal at both ends as shown below.  
 -Drill 0.236" diameter (#B bit) holes and countersink for #12 flat head fasteners. Screw heads must be flush with face of horizontal.

See **Details 11 thru 13**.

**Note:** For 3-1/4" back depth open back horizontals (shown below in **Detail 11**), fabrication is the same as for the tubular horizontal. Other open back horizontals (shown on **Pages 27 & 28**) have different fabrication compared to their respective tubular versions.

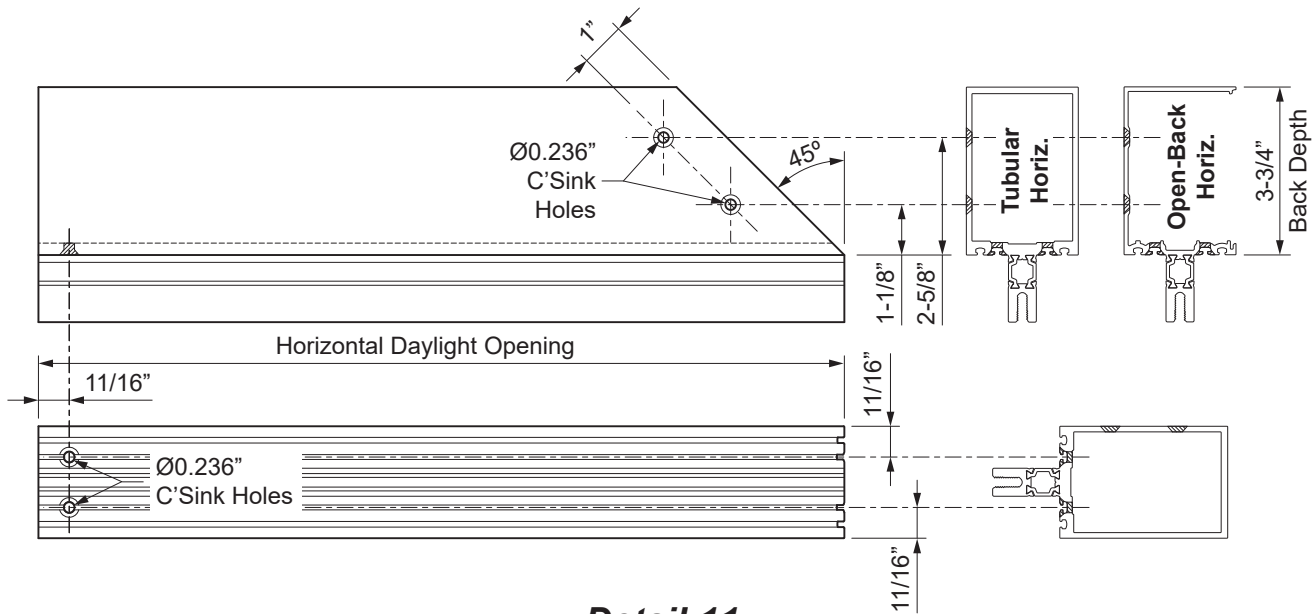

**Detail 11**

FRAME FABRICATION

STEP 7 (Continued)

FABRICATE HORIZONTAL MEMBERS @ 90° OUTSIDE CORNER

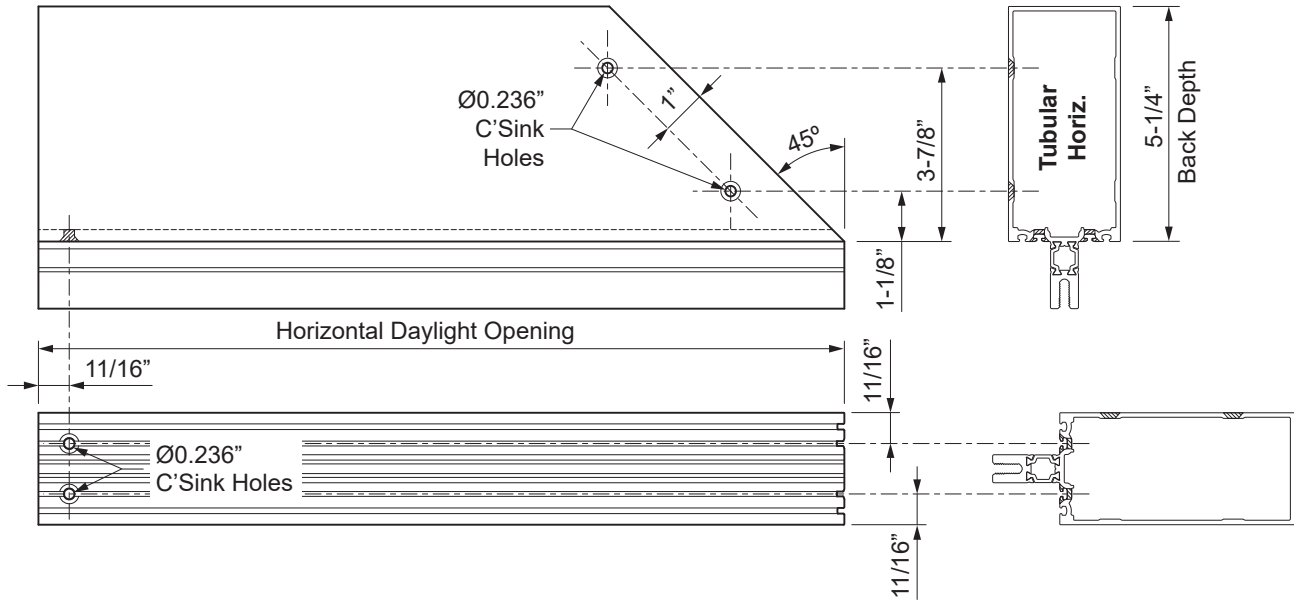

**Detail 12**

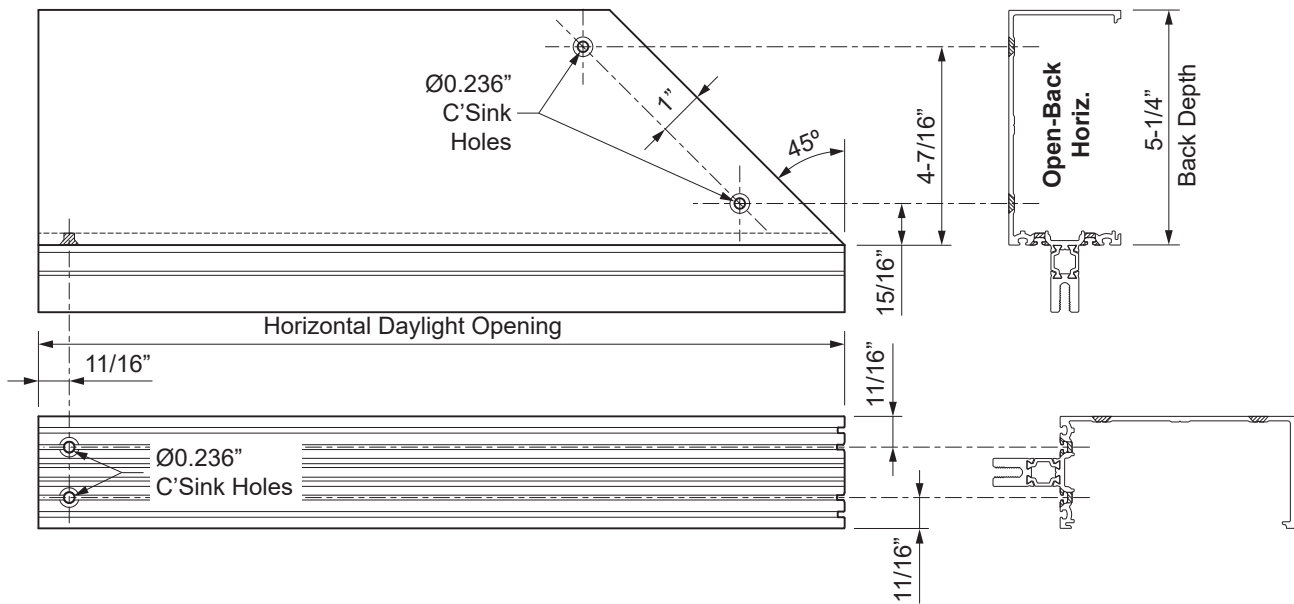

**Detail 12A**

**FRAME FABRICATION**

**STEP 7 (Continued)**

**FABRICATE HORIZONTAL MEMBERS @ 90° OUTSIDE CORNER**

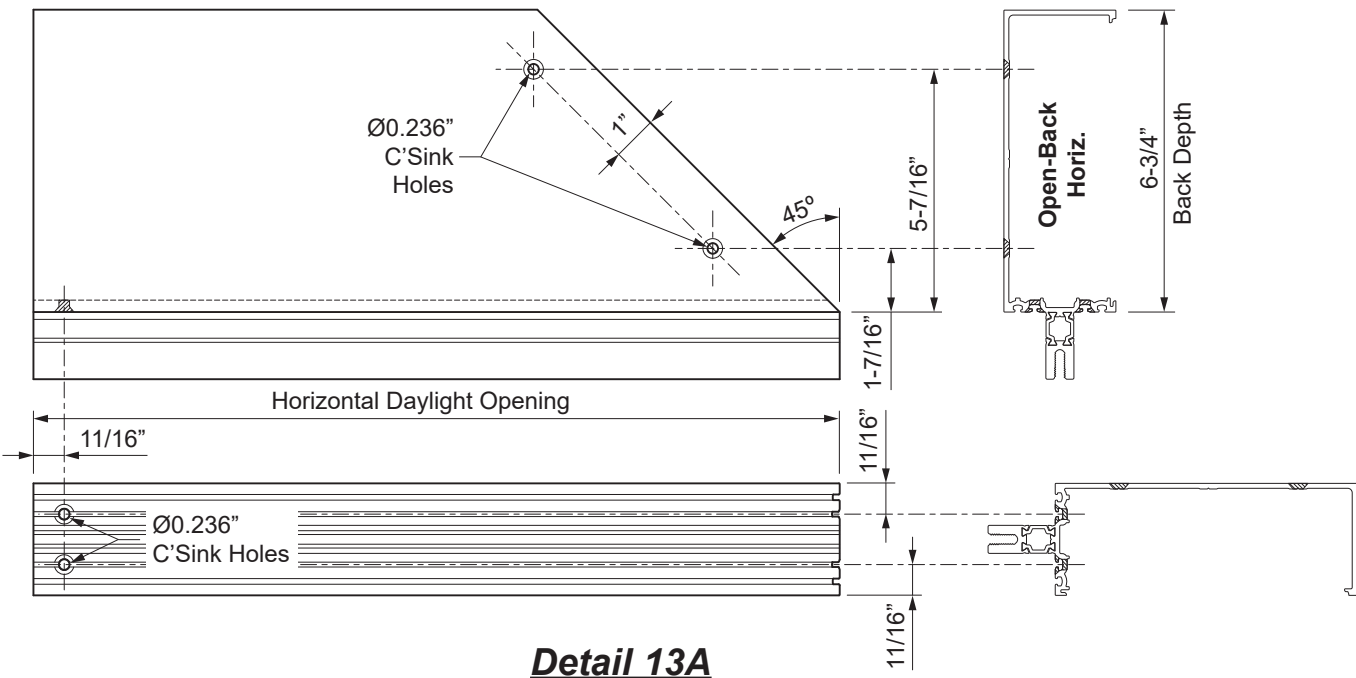
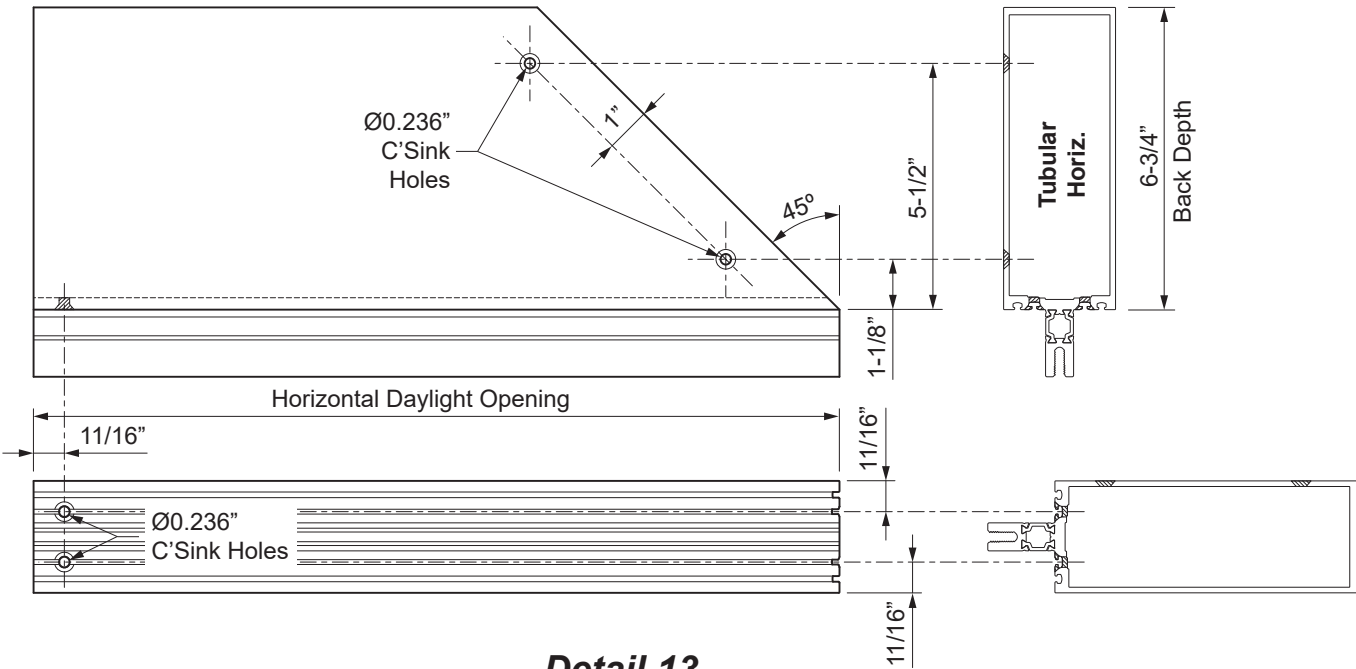



## FRAME FABRICATION

### STEP 7 (Continued) FABRICATE HORIZONTAL MEMBERS

#### Open Back Head & Sill with “T” & “F” Anchors:

- Open back head & sill members require holes to access anchor bolts.
- Drill 1-1/2” dia. holes at anchor locations as required by approved shop drawings or engineering calculations.

See **Detail 14**.

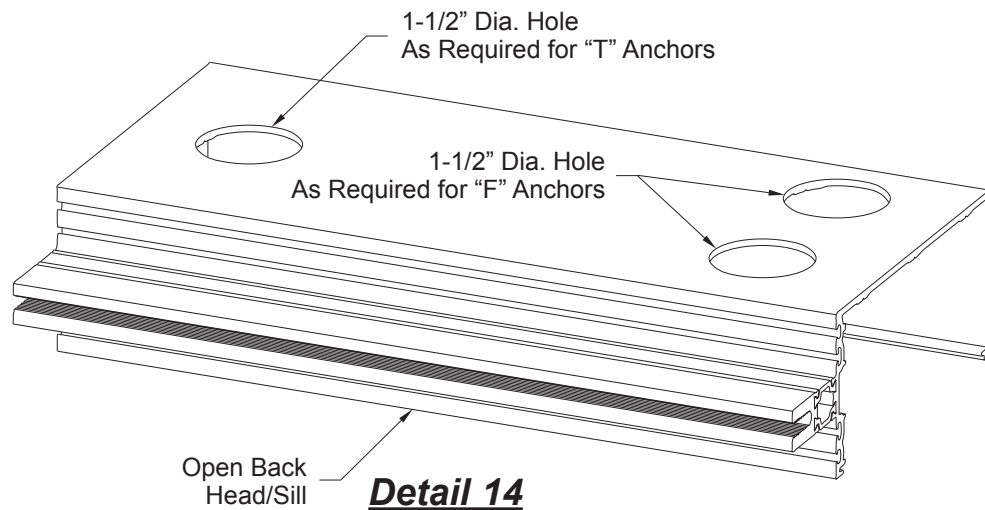

#### Tubular Head & Sill with “J”, “F” & “T” Anchors:

- Tubular head and sill members must be notched at each end to clear mullion end anchors and anchor bolts.
- See **Detail 15** below for notch dimensions.

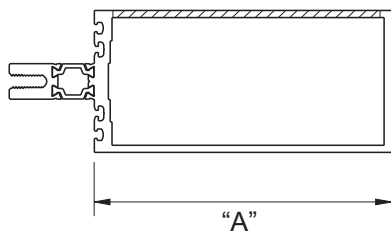

Dim “A”	Dim “B”
6-3/4”	6-1/4”
5-1/4”	4-3/4”
3-3/4”	3-1/4”

Notch Horizontal  
Ends to Clear  
End Anchors  
& Anchor Bolts

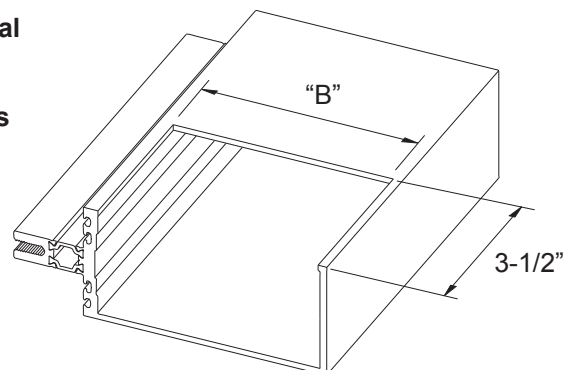

**Detail 15**

## FRAME FABRICATION

### STEP 8 FABRICATE PRESSURE PLATES

#### Horizontal Pressure Plates:

- Cut horizontal pressure plates to the daylight opening between verticals minus(-) 1/4".
- Pressure plate stock lengths have 0.281" dia. attachment holes factory made every 9".
- After cutting, drill additional holes if required to ensure that end holes are 1-1/2" from each end.
- Drill 3 weep holes per daylight opening (D.L.O.). Weep holes must be 0.313" diameter and must be located 3" from each end of the D.L.O. and at the centerline of D.L.O. as shown in **Detail 16**.

**Note:** If the space between the weep holes exceeds 3', additional weep holes should be drilled to ensure that there is no more than 3' between the weep holes.

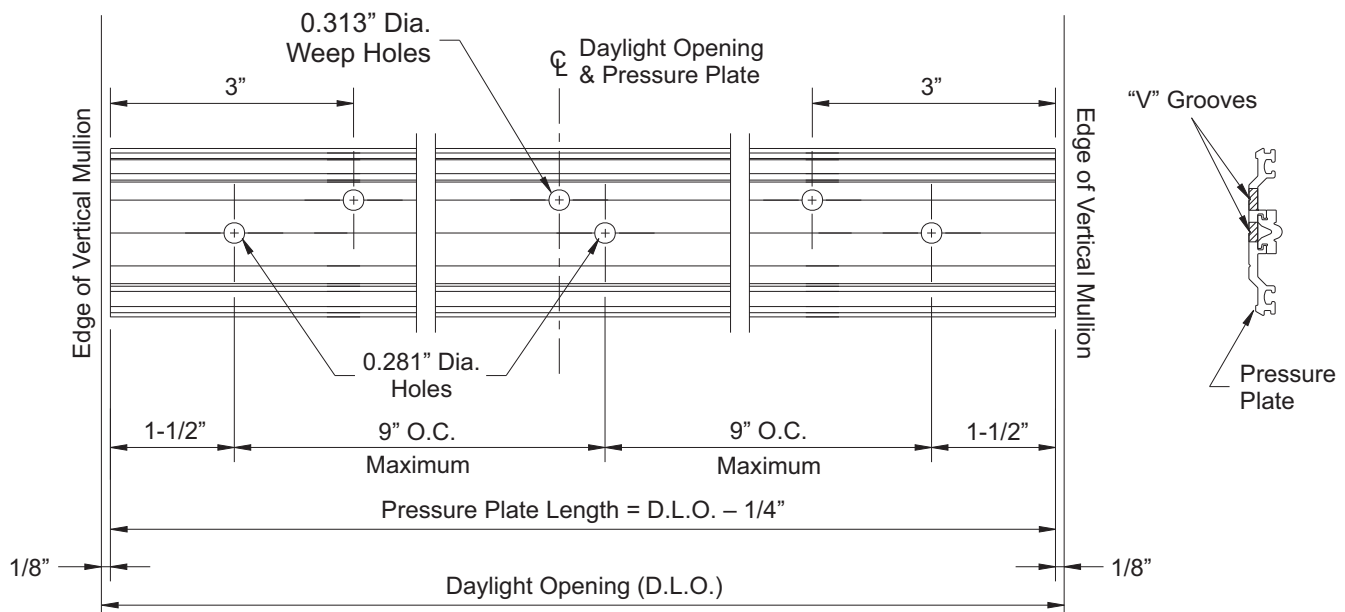

**Detail 16**

#### Vertical Pressure Plates:

- Cut mullion and jamb pressure plates to the same length as the mullions.
- If mullions are spliced, cut pressure plates to accommodate for 1/2" expansion joint as shown in **Step 11** on **Pages 33 & 34**.
- Drill additional attachment holes if required to ensure that end holes are 1-1/2" from each end.

## FRAME FABRICATION

### STEP 9 FABRICATE FACE COVERS

#### Horizontal Face Covers:

- Cut horizontal face covers to the daylight opening between mullions minus(-) 1/16".
- Drill two 0.313" diameter weep holes at 1/3 points of cover as shown below.

**Face cover weep holes must not align with pressure plate weep holes.**

See **Detail 17**.

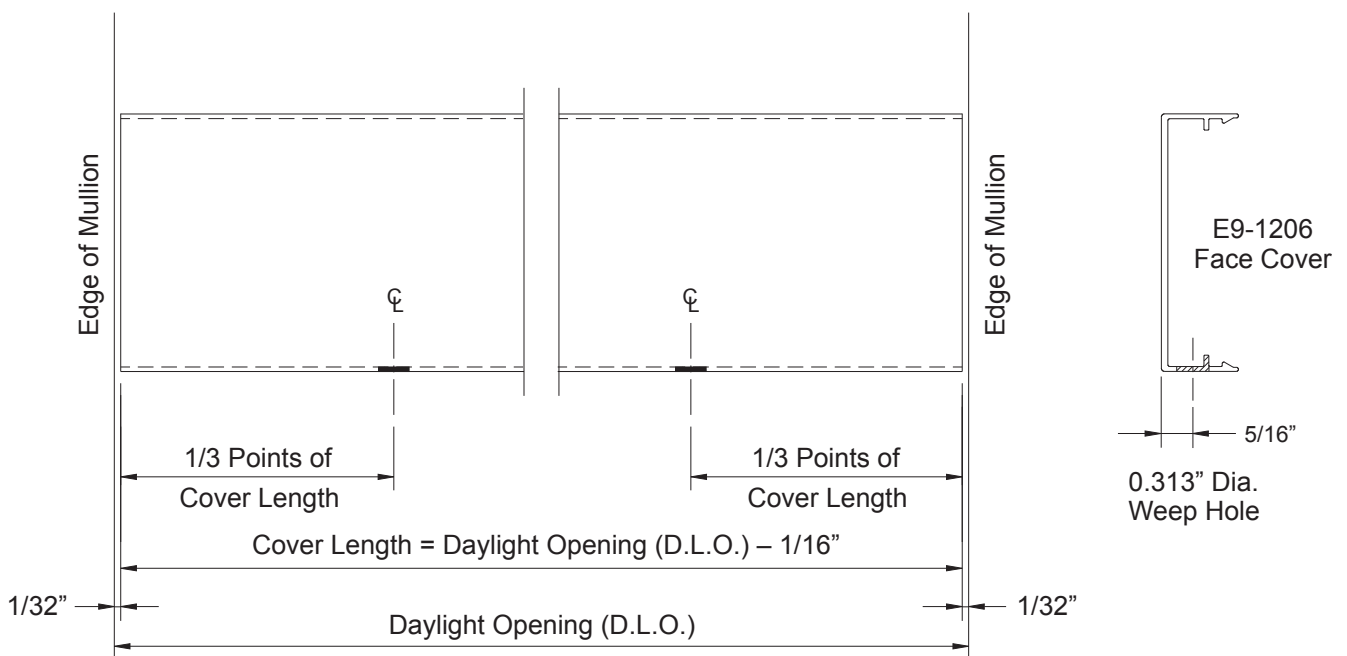

**Detail 17**

#### Mullion Face Covers:

- Cut mullion face covers to the same length as the mullions unless the verticals are spliced.
- If mullions are spliced, cut mullion face covers to accommodate for the 1/2" expansion joint as shown in **Step 11**.

## FRAME FABRICATION

### STEP 10

#### FABRICATE SILL FLASHING (Optional)

- Cut sill flashing to the frame width plus(+) 3/8".\*
- Drill 0.213" diameter clear holes through the "V" groove of the sill flashing as shown below.
- The round nub at the back side of the sill flashing will interfere at the mullion locations. Remove 3 inches of this nub at all vertical mullion locations. See **Detail 18**.

- \*Note:** For openings longer than 24'-0" the sill flashing needs to be spliced every twelve to fifteen feet.
- Allow for a 3/8" joint for expansion between sill flashing members.

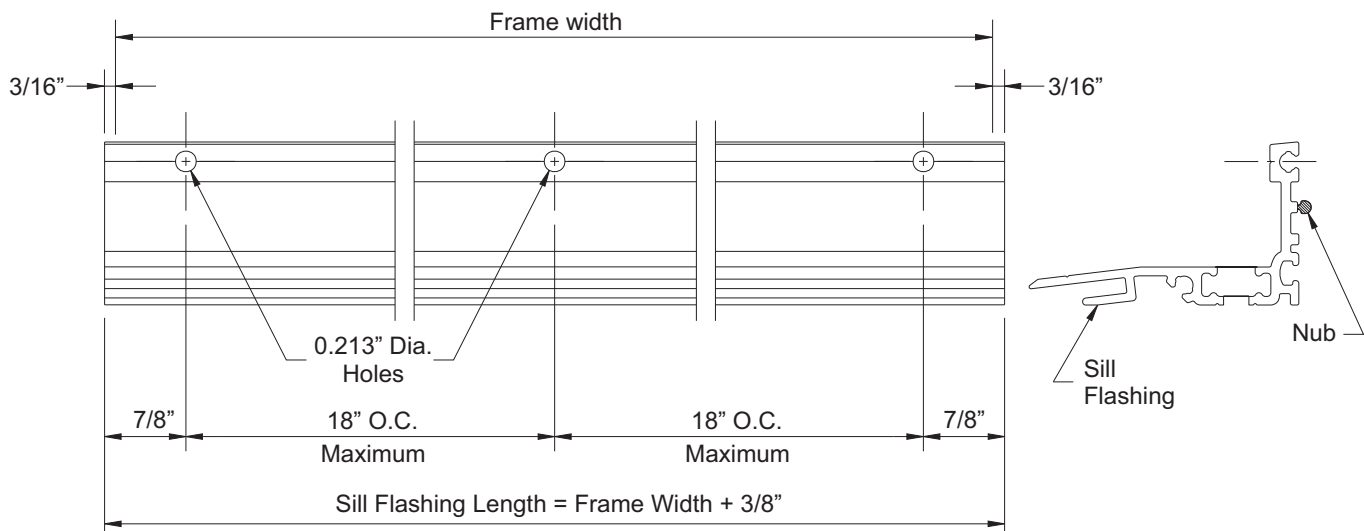

### **Detail 18**

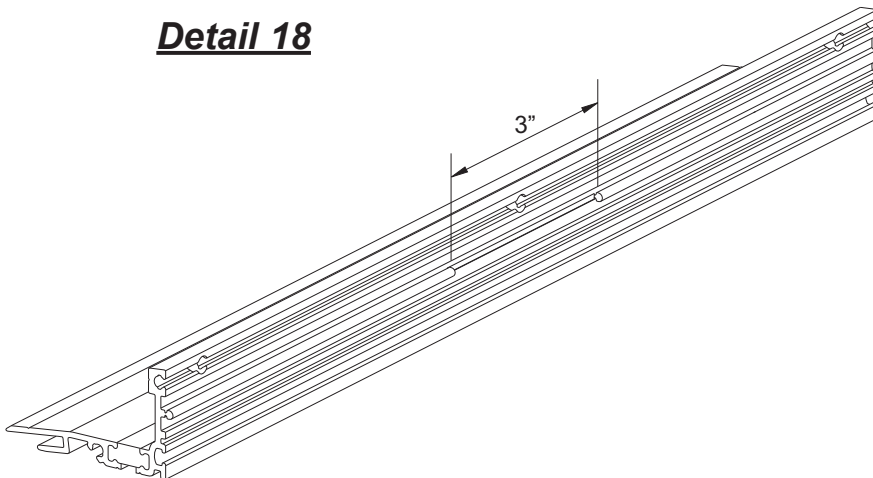

## FRAME INSTALLATION

### STEP 11 TYPICAL VERTICAL SPLICE

Stagger Mullion, Pressure Plate, and Cover Splice Joints as Shown Below.

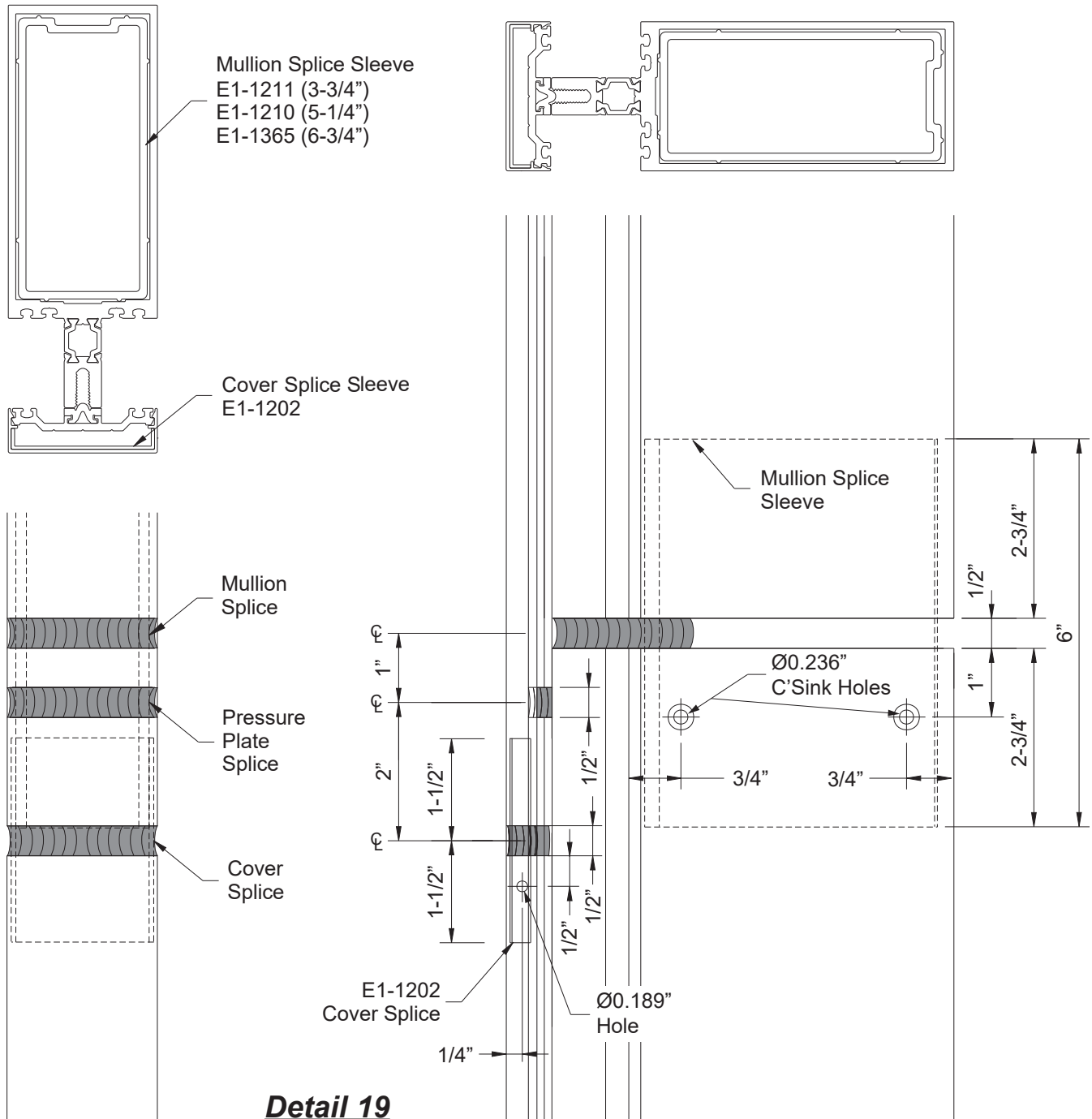

## FRAME INSTALLATION

### STEP 11 (Continued) TYPICAL VERTICAL SPLICE

- Clean all surfaces as recommended by sealant manufacturer.
- At 3/4" from the front and back of the lower mullion and down 1" from the top, drill Ø0.236" (#B drill bit) holes, and countersink for #12 flat head fasteners, on each side of the mullion.
- Apply bond breaker tape to the face of the splice sleeve at its midpoint (3" from top or bottom).
- Lower the splice sleeve into top of lower mullion 2-3/4" and attach with two FC-1212 fasteners on both sides of the mullion.
- When using 1" glazing mullions, stuff a small piece of backer rod 1/2" down the cavity behind mullion tongue and pump in sealant to fill the cavity.
- Apply sealant to the face of splice sleeve on the upper half and carefully slide the upper mullion down onto the splice sleeve. Place a 1/2" temporary shim between the mullions to locate them.
- Secure the upper mullion to the mid anchors and remove the temporary shims.
- Apply and tool sealant to the face and sides of the splice sleeve to create a water tight joint.

-Leave a 1/2" expansion joint between vertical pressure plate splices and fill the joint with sealant.

-Locate pressure plate fasteners 1-1/2" from each end of pressure plate splice as shown.

-Apply bond breaker tape to the face of the cover splice sleeve and attach it to the lower face cover with a PF-0808-SS fastener on each side.

-Prior to snapping on the upper portion of the face cover, apply sealant to the face of the splice.

-Leave a 1/2" expansion joint between face cover splices.

See **Details 19 & 20**.

**Note:** Face covers, pressure plates, and mullions are staggered at splice locations.

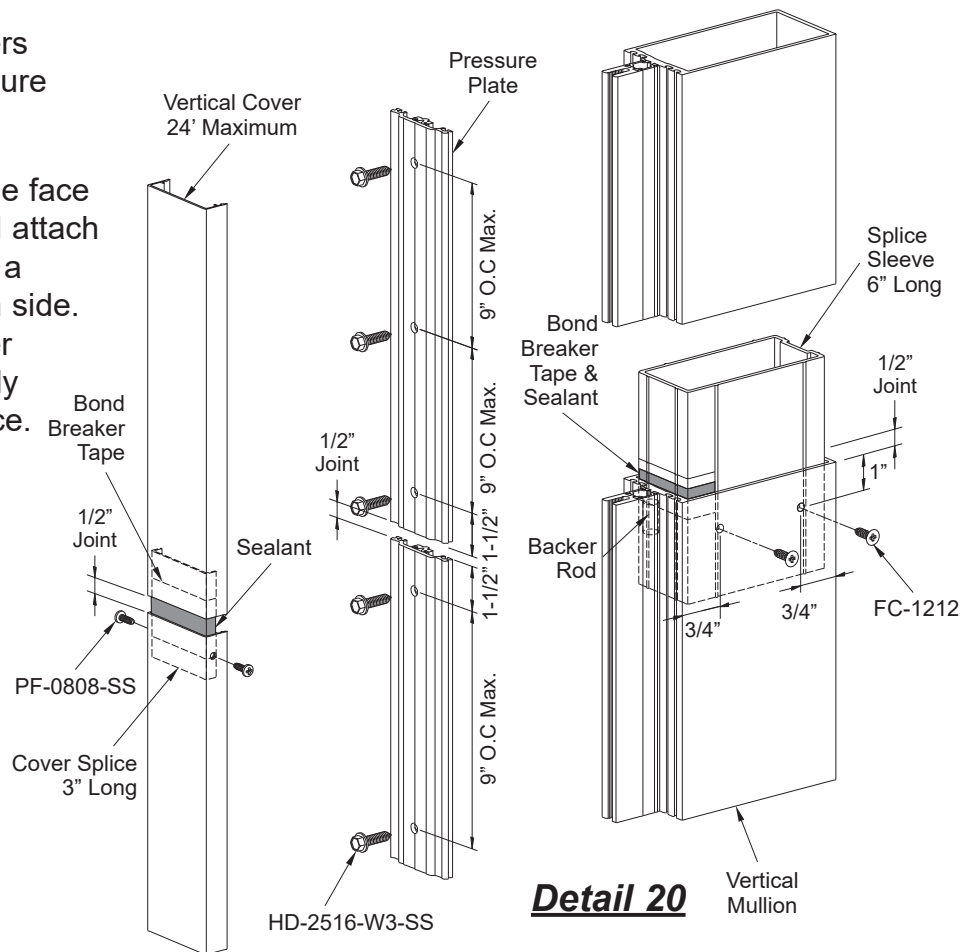

## FRAME INSTALLATION

### STEP 12 (When Required) INSTALL CONTINUOUS PERIMETER ANCHOR (1" INFILL ONLY)

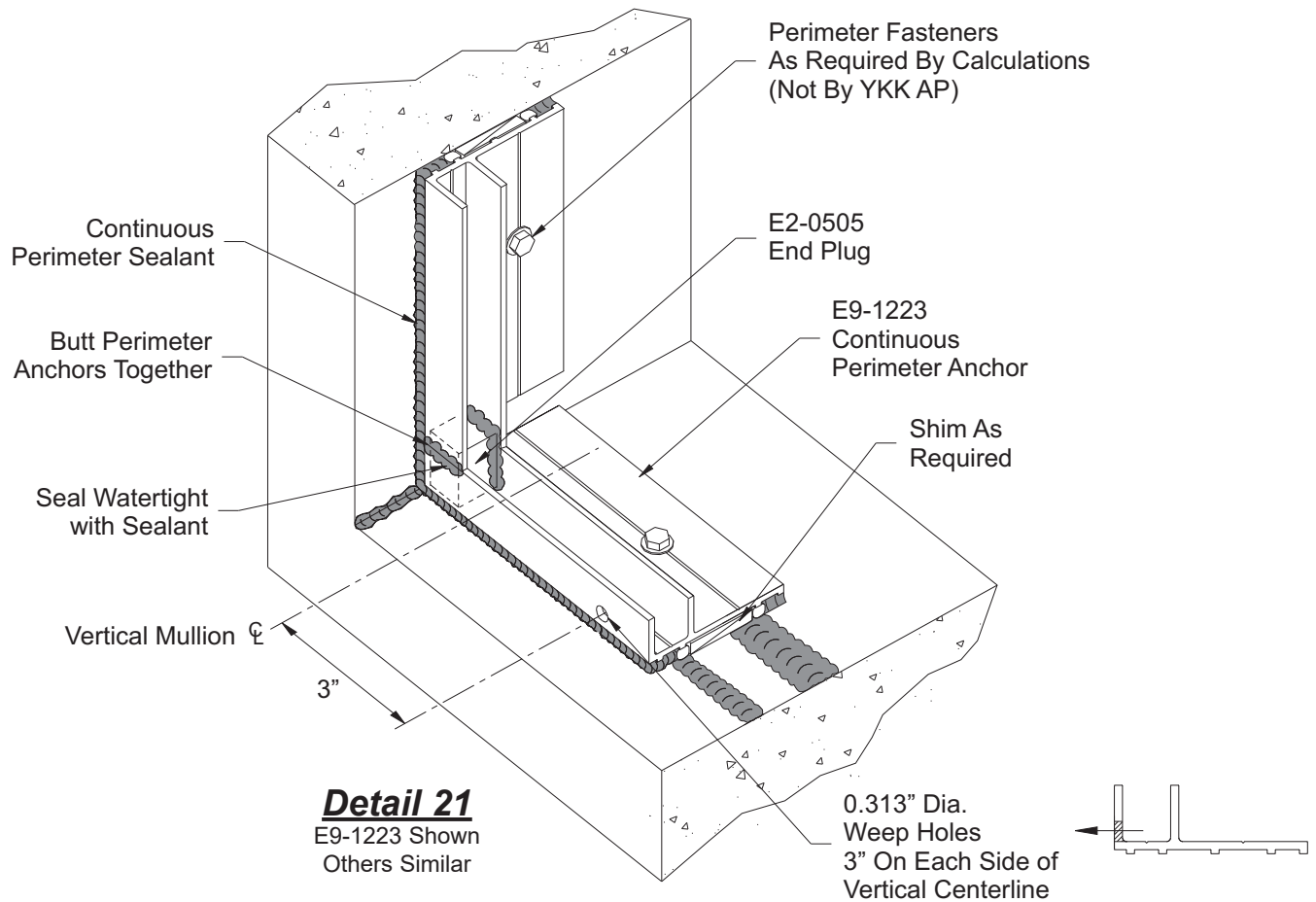

- Cut perimeter anchors to size:  
Head and sill anchors stop 1/8" short of the structure.  
Vertical jamb anchors butt in between head and sill anchors.
- Prepare structure for anchor attachment.
- Install perimeter anchors with appropriate perimeter fasteners. Refer to shop drawings or engineering calculations for type and spacing of fasteners. Shim as required to install anchors level.
- When splicing head and sill pieces together, leave 3/8" joint for expansion and install end plug, E2-0505, that has been buttered with sealant on the front, back, and bottom at the joint.
- Run continuous sealant along the perimeter between the anchors and the substrate.
- Seal corners of butted perimeter anchors watertight with sealant.
- Butter E2-0505 end plug with sealant on all sides that touch the anchors.  
Then push end plug into place and tool excess sealant that comes through the cracks.
- Field drill 0.313" diameter weep holes in perimeter anchor (exterior face only) at sill 3" from center line of vertical on each side.

See **Detail 21**.

## FRAME INSTALLATION

### STEP 13 (When Required) JAMB/VERTICAL INSTALLATION WITH PERIMETER ANCHORS (1" INFILL ONLY)

- Install interior gasket, E2-0120, to jamb mullion (jamb side only) the full length of the mullion.
  - Position jamb into opening as shown below.
  - Seal the gap between the perimeter anchor and mullion glazing pocket(s) with sealant (one side for jambs – both sides for intermediate mullions).
  - Install temporary retainer clip, E1-3612, at the top and bottom of the mullion.
  - Repeat this step for all jamb and mullion members.
- See **Detail 22**.

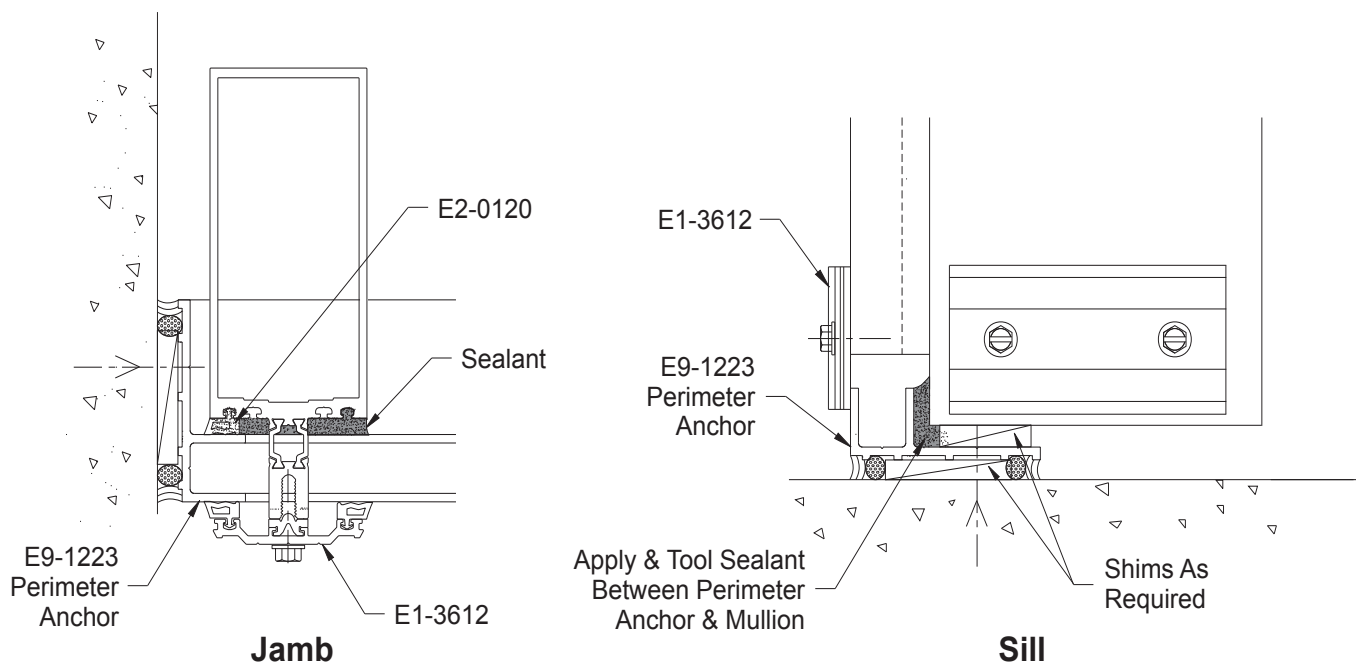

**Detail 22**  
E9-1223 Shown  
Others Similar

Sill Shown  
Head Similar



## FRAME INSTALLATION

### STEP 14 JAMB/VERTICAL INSTALLATION WITH MULLION END ANCHORS

- Clean all contact surfaces as recommended by sealant manufacturer.
  - Apply sealant into the screw raceway and along the front edge of the mullion at each end.
  - Prior to erecting mullions, install mullion end caps at the top and bottom of all intermediate mullions and jambs with FC-1410 fasteners.
  - Seal all screw heads with sealant.
- See **Detail 23**.

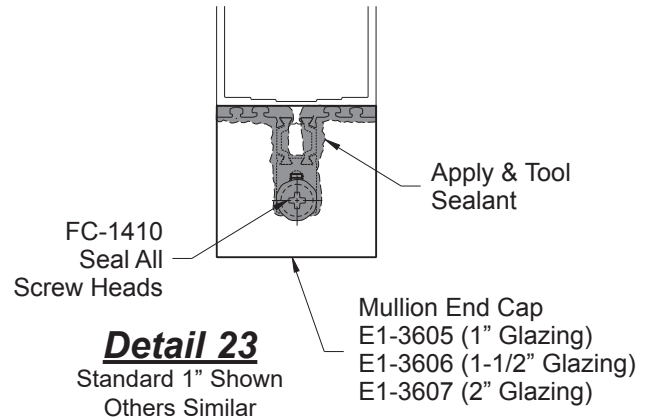

- Insert mullion "T" and "F" anchors into the top and bottom of the mullions before erecting them into the opening.
  - Erect and locate the jamb and mullions and temporarily attach them to the structure. All mullions must be installed plumb and true.
  - Drill through the pre-drilled holes in "T", "F" and "J" anchors into the structure for the appropriate anchor fasteners according to approved shop drawings or engineering calculations.
- Note:** When using T and F anchors, shims should be located between the of the T or F anchor and the bottom of the vertical mullions as shown in **Detail 24**.

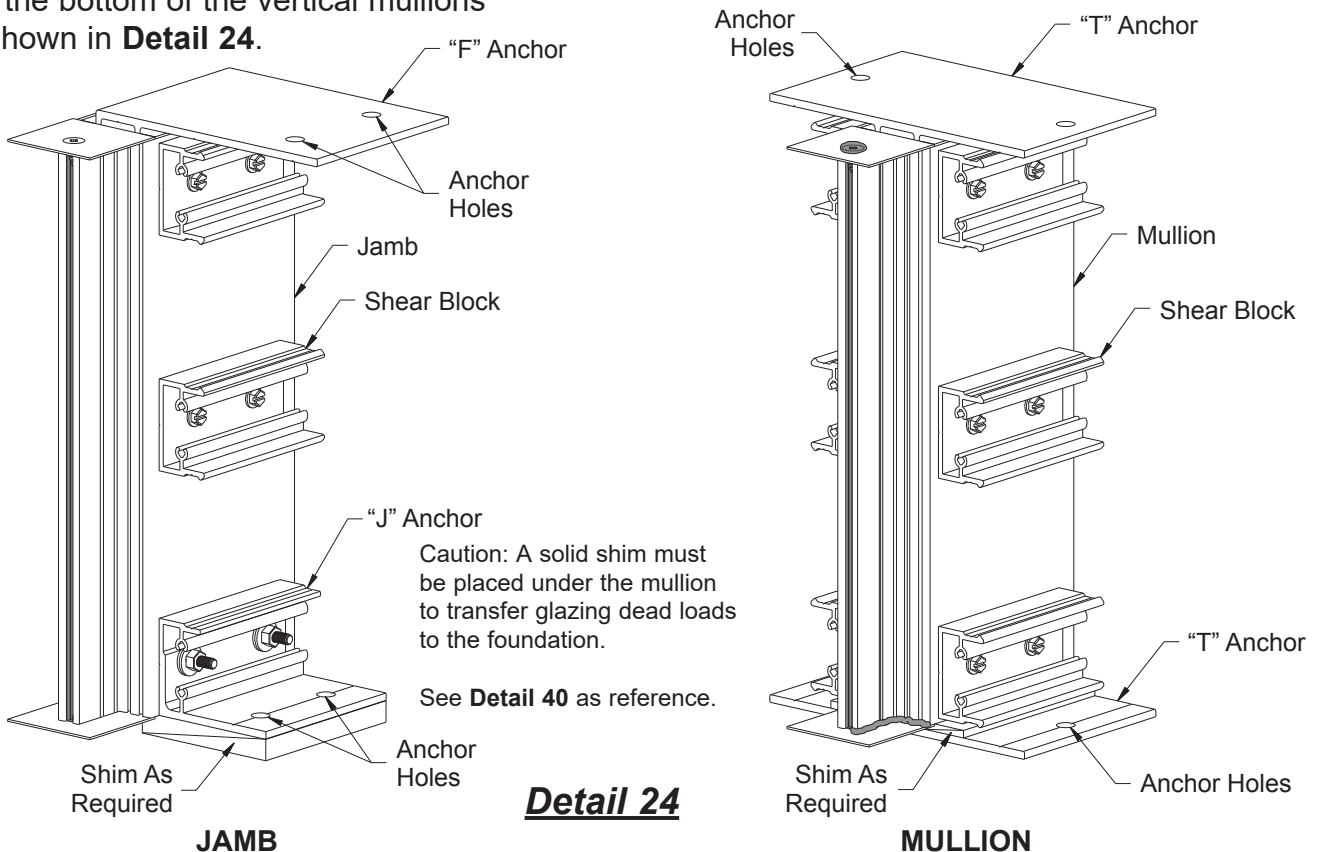

## FRAME INSTALLATION

### STEP 14A VERTICAL INSTALLATION AT DOOR JAMB END ANCHORS

The mullions at the door jambs are set directly upon the sill substrate without any shims and are sealed against the substrate. The anchors to be used at this location are specified by the approved shop drawings and or P.E. calculations.

-Locate the mullion anchor for the door jamb and install it to the substrate according to the approved shop drawings and P.E. calculations.

**Note:** if using an exposed fasteners shear block as a mullion anchor, check to ensure the sill shear block fasteners will not cause interference. Field modify the shear block anchor as required. See **Detail 26**.

-Clean all contact surfaces as recommended by sealant manufacturer.

-Set the mullion on the anchor, directly onto the sill substrate in a bed of sealant. Avoid using shims at this location.

See **Detail 25**.

-Refer to the approved shop drawings for any additional fasteners required at anchor.

-Tool sealant at the bottom of the mullion at the sill substrate around the perimeter of the mullion.

See **Detail 27**.

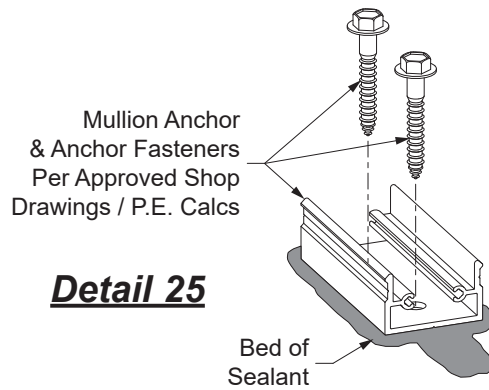
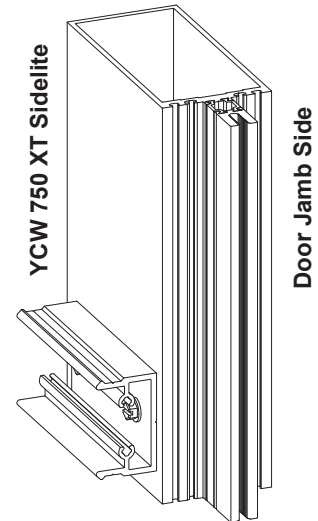

**Detail 25**

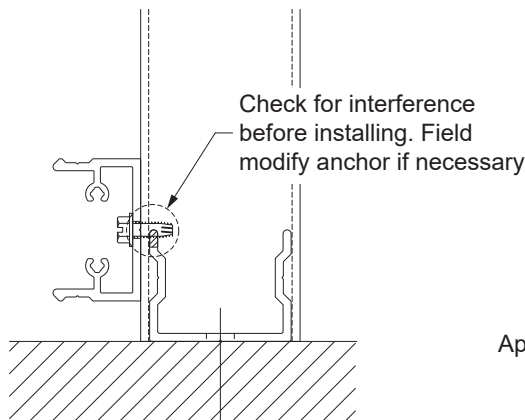

**Detail 26**

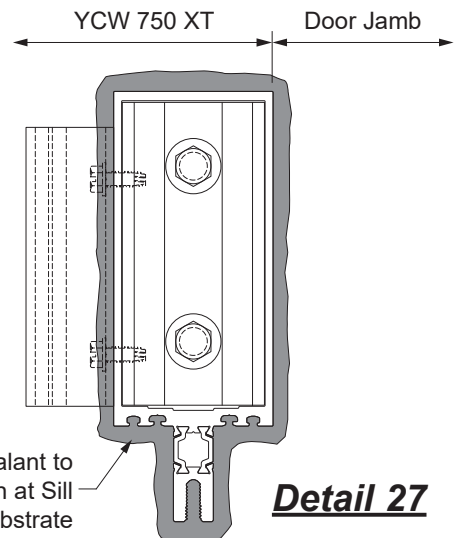

**Detail 27**

## FRAME INSTALLATION

### STEP 15 INSTALL WIND LOAD/DEAD LOAD ANCHORS

-Install steel wind load and dead load anchors. Anchor are normally template or line set before mullions are hung. Outstanding leg of anchor must be set at 90° to offset line. The back of the mullion should set about 1" from the anchoring substrate. See **Detail 28**.

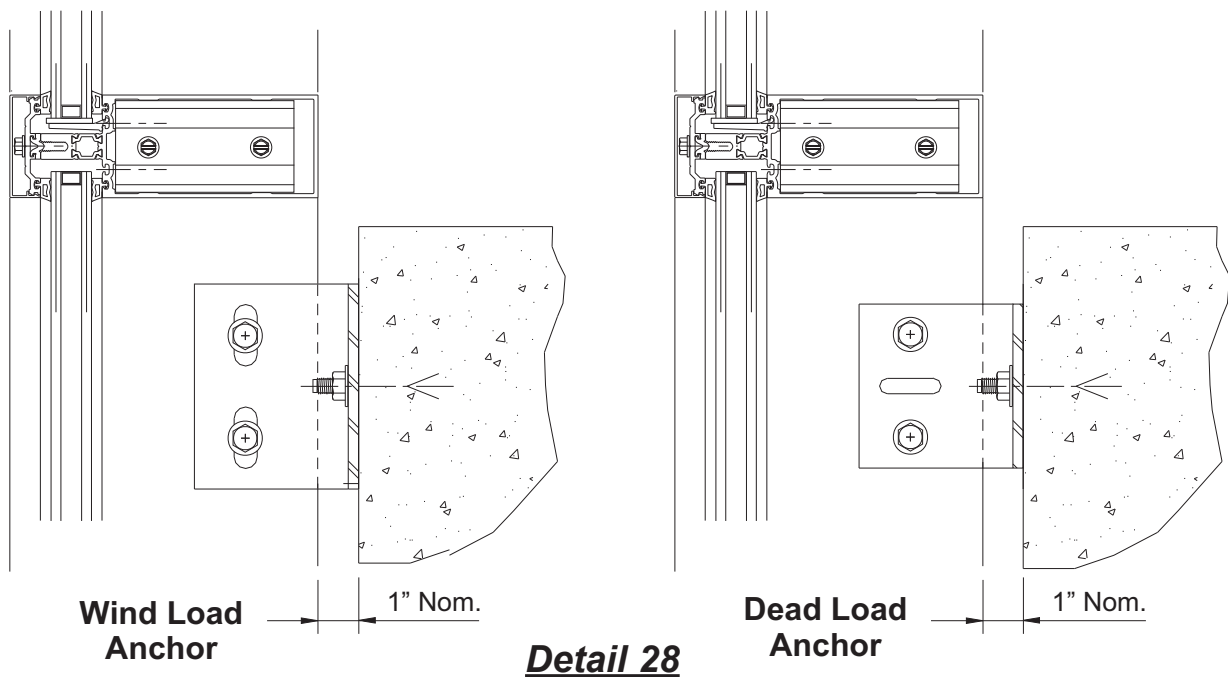

-Install, plumb, and align mullions. Drill and install appropriate diameter anchor bolts per approved shop drawings or engineering calculations.  
-Nylon slip pads, E3-0103, must be installed between mullion and anchors. See **Detail 29**.

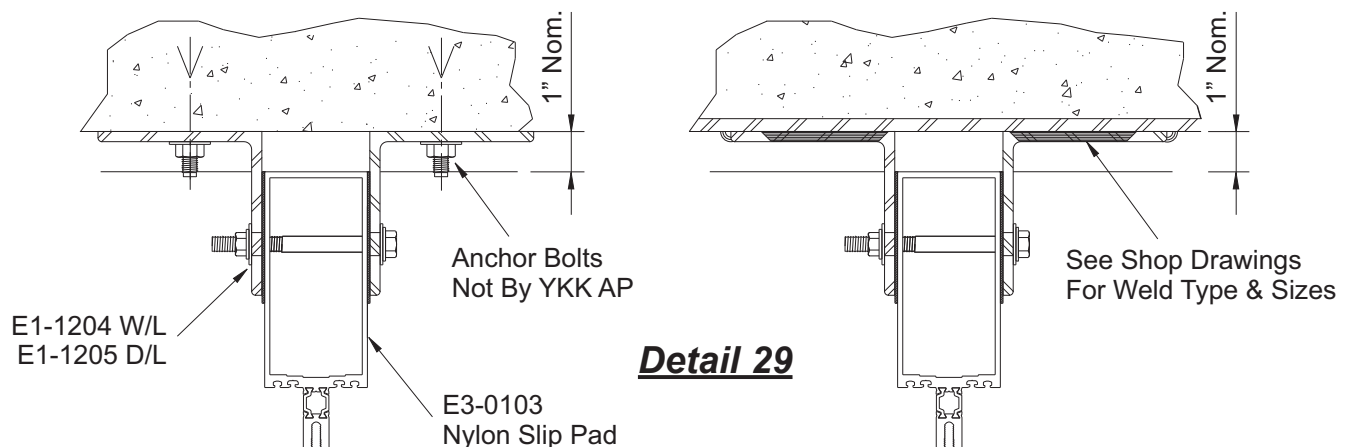

**FRAME INSTALLATION**

**TYPICAL WIND LOAD ANCHOR**

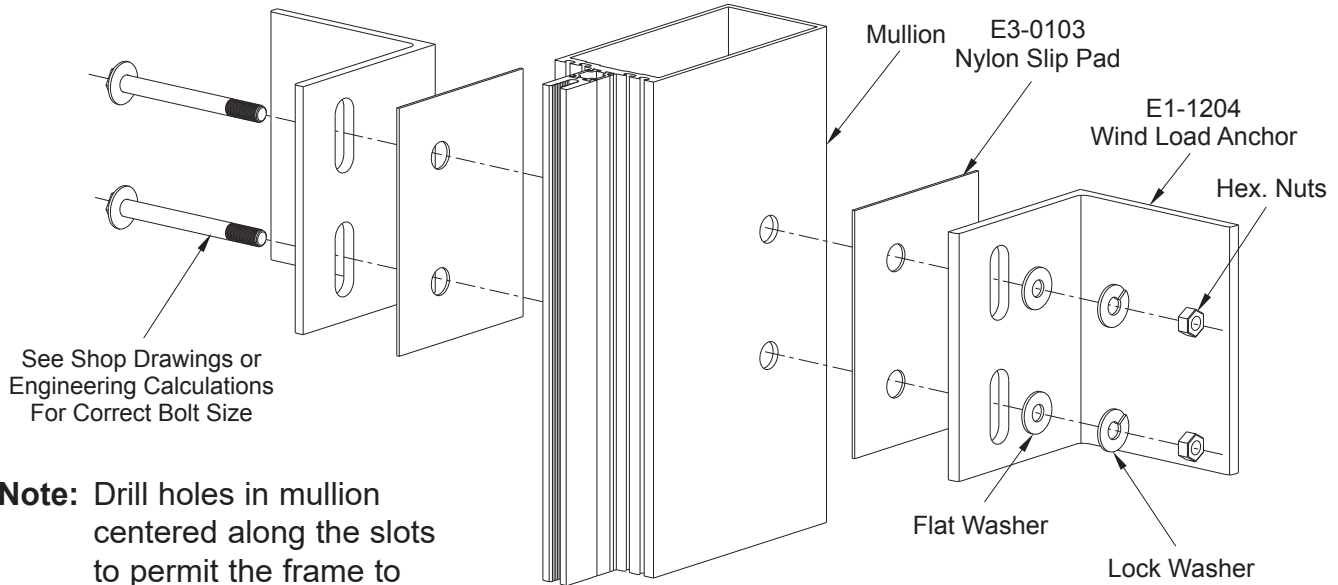

**Note:** Drill holes in mullion centered along the slots to permit the frame to contract and expand.

**Detail 30**

**TYPICAL DEAD LOAD ANCHOR**

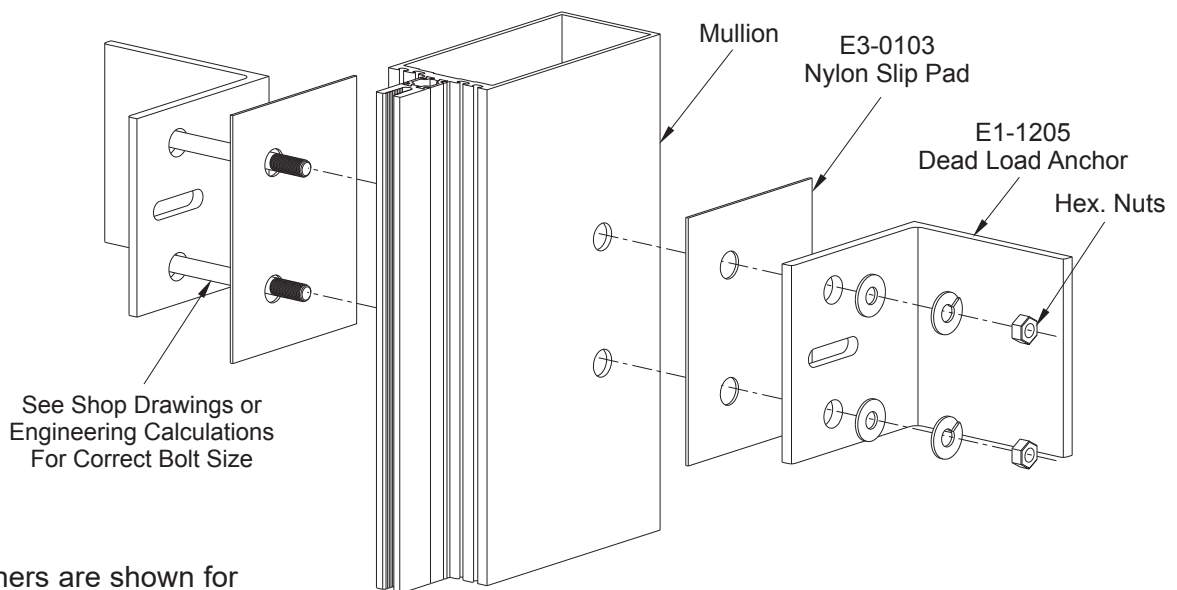

**Note:** Fasteners are shown for reference only; horizontals are typically attached before anchor fasteners are installed.

## FRAME INSTALLATION

### JAMB WIND LOAD ANCHOR

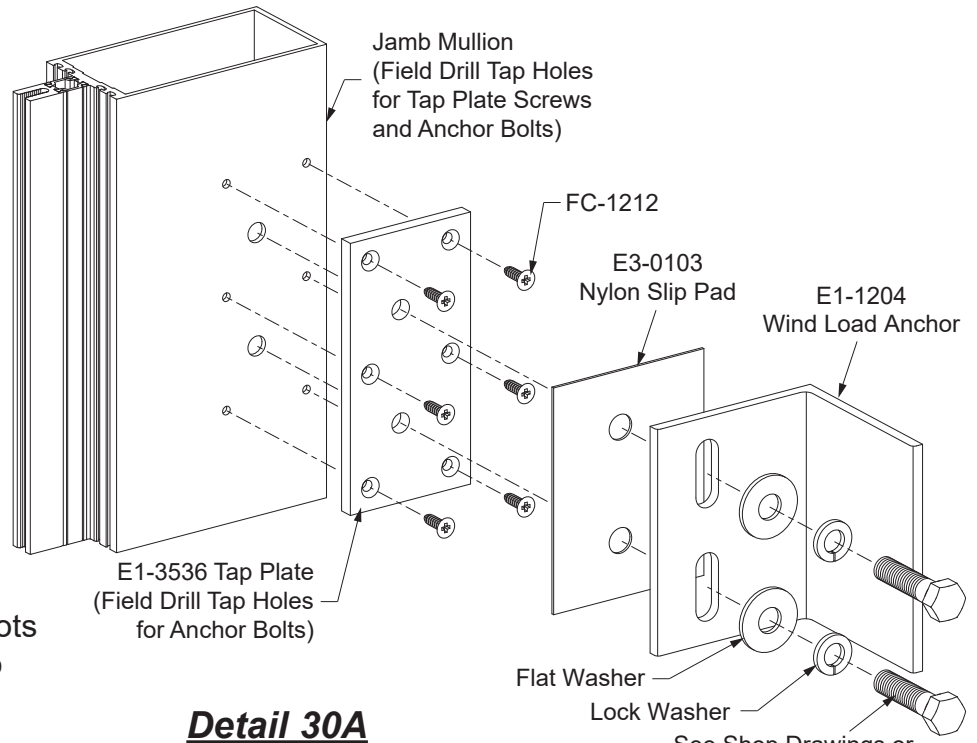

**Note:** Drill holes in mullion centered along the slots to permit the frame to contract and expand.

### Detail 30A

See Shop Drawings or Engineering Calculations For Correct Bolt Size (Not By YKK AP)

### JAMB DEAD LOAD ANCHOR

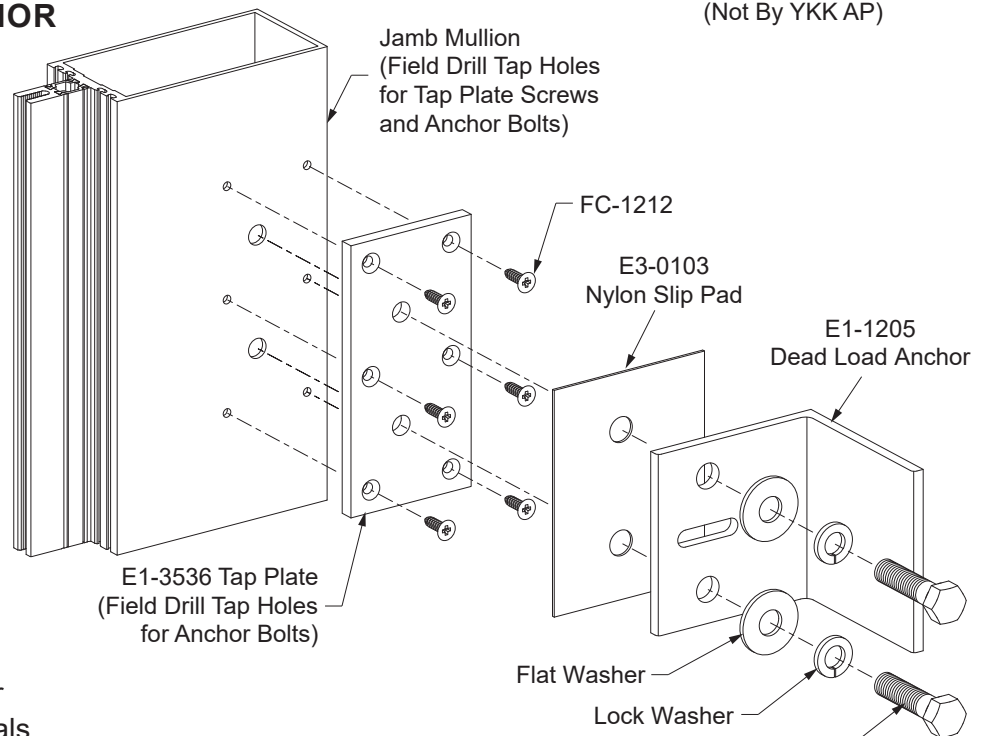

**Note:** Fasteners are shown for reference only; horizontals are typically attached before anchor fasteners are installed.

See Shop Drawings or Engineering Calculations For Correct Bolt Size (Not By YKK AP)

## FRAME INSTALLATION

### STEP 16

### ATTACH HORIZONTAL MEMBERS

**Note:** Before applying any sealant, clean aluminum surfaces using cleaner and method approved by sealant manufacturer.

-Just prior to attaching the horizontal members to the mullions, apply sealant to the front of the shear block as shown.

#### Horizontals with Concealed Fasteners:

- Slide the horizontal members towards the mullion and attach them to the shear blocks at each end with two FC-1220 fasteners.
- Tool and wipe away any excess sealant at the mullion to horizontal joints, and exposed front fasteners.

See **Detail 31**.

#### CONCEALED FASTENERS

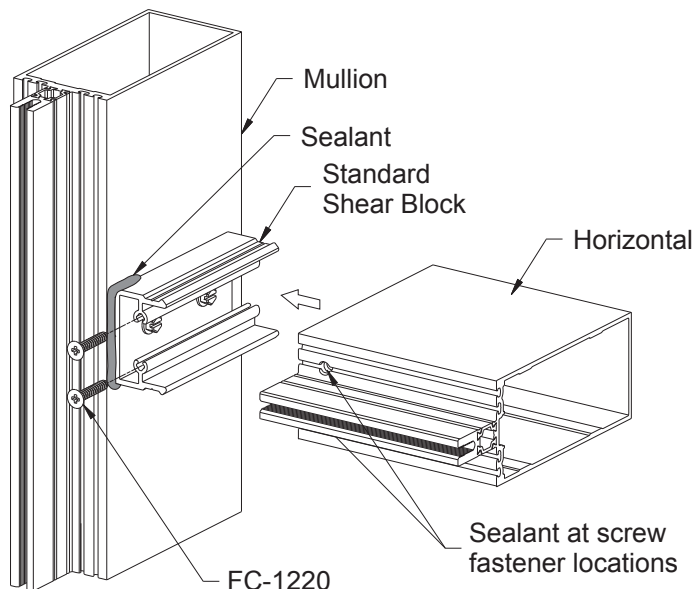

**Detail 31**

#### Horizontals with Exposed Fasteners:

- Slide the horizontal members towards the mullion and transfer the hole locations on top of the horizontal to the shear block.
- Remove the horizontal and drill a 0.189" dia. (#12 bit) hole at each hole location.
- Slide the horizontal back against the mullion and attach it to the shear block with two FC-1212 fasteners at each end.
- Tool and wipe away any excess sealant at the mullion to horizontal joints.

See **Detail 32**.

#### EXPOSED FASTENERS

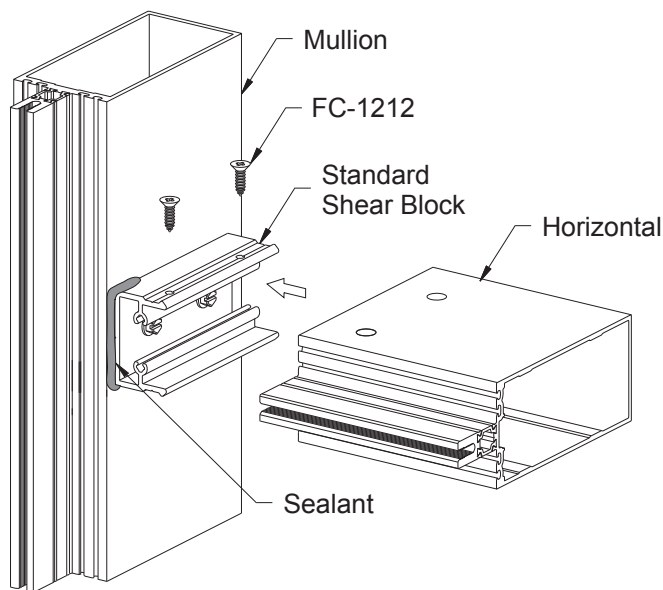

**Detail 32**

## FRAME INSTALLATION

### STEP 16 (Continued) ATTACH HORIZONTAL MEMBERS

#### Open Back Intermediate Horizontals:

- Just prior to attaching the horizontal members to the mullion, apply sealant to the front of the shear block as shown below.
  - Lower the horizontal down onto the shear block. Make sure the horizontal and mullion glazing pockets are flush.
  - Attach the horizontal to the shear block at the face of the horizontal with two FC-1220 fasteners at each end.
  - Tool and wipe away any excess sealant at the mullion to horizontal joints, and exposed front fasteners.
  - Snap on the mullion flush filler.
- See **Detail 33**.

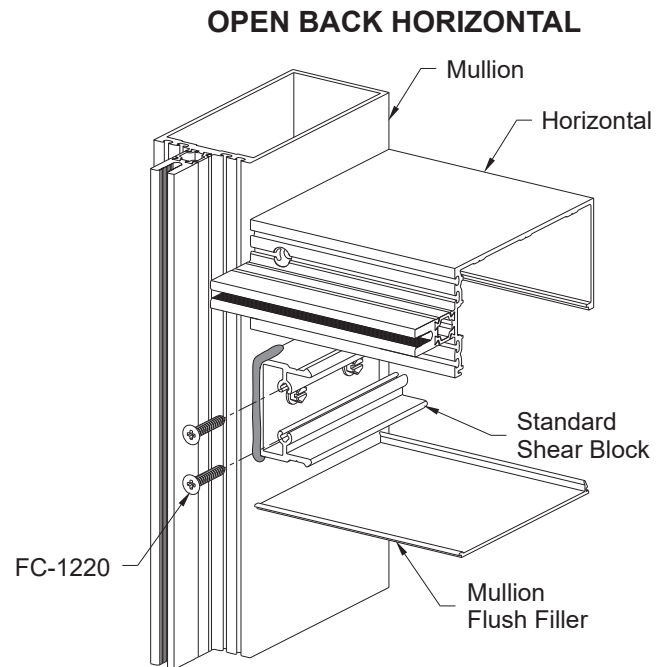

**Detail 33**

#### Open Back Head & Sill Members at End Bays:

- To clear the vertical mullions at end bays shear blocks must be pre-attached to the head and sill members through the face of the mullion with FC-1220 fasteners.
  - Position the head/sill members into place and attach the shear blocks to the mullions with two HF-2510-W1 fasteners per block.
  - Provide anchor fasteners per approved shop drawings or engineering calculations.
  - Install the anchor fasteners as recommended by fastener manufacturer.
  - Snap on the mullion flush filler.
- See **Detail 34**.

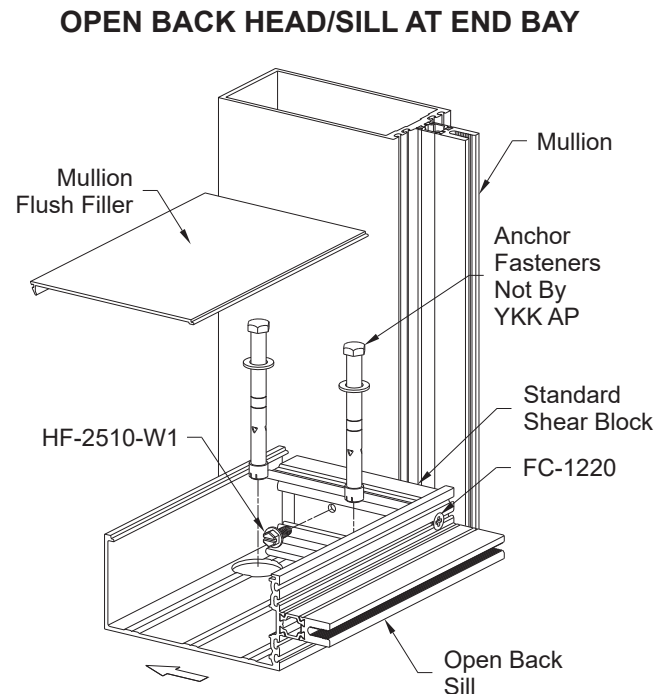

**Detail 34**  
Sill Shown, Head Similar

**Caution:** A solid shim must be placed under the mullion to transfer glazing dead loads to the foundation.

**FRAME INSTALLATION****STEP 16 (Continued)****ATTACH HORIZONTAL MEMBERS AT 90° OUTSIDE CORNER MULLIONS**

**Note:** Before applying any sealant, clean aluminum surfaces using cleaner and method approved by sealant manufacturer.

- Just prior to attaching the horizontal members to the corner mullion, apply sealant to the front of the shear block as shown in **Detail 35**.
- Attach the horizontal members at the mitered end to the corner mullion at the shear blocks with fasteners as shown below.
- When using incidental water head members, match drill 0.189" tap holes into the shear clips. Attach the incidental water head using PC-1208 screws.
- Tool and wipe away any excess sealant at the vertical to horizontal joints.

See **Detail 35**.

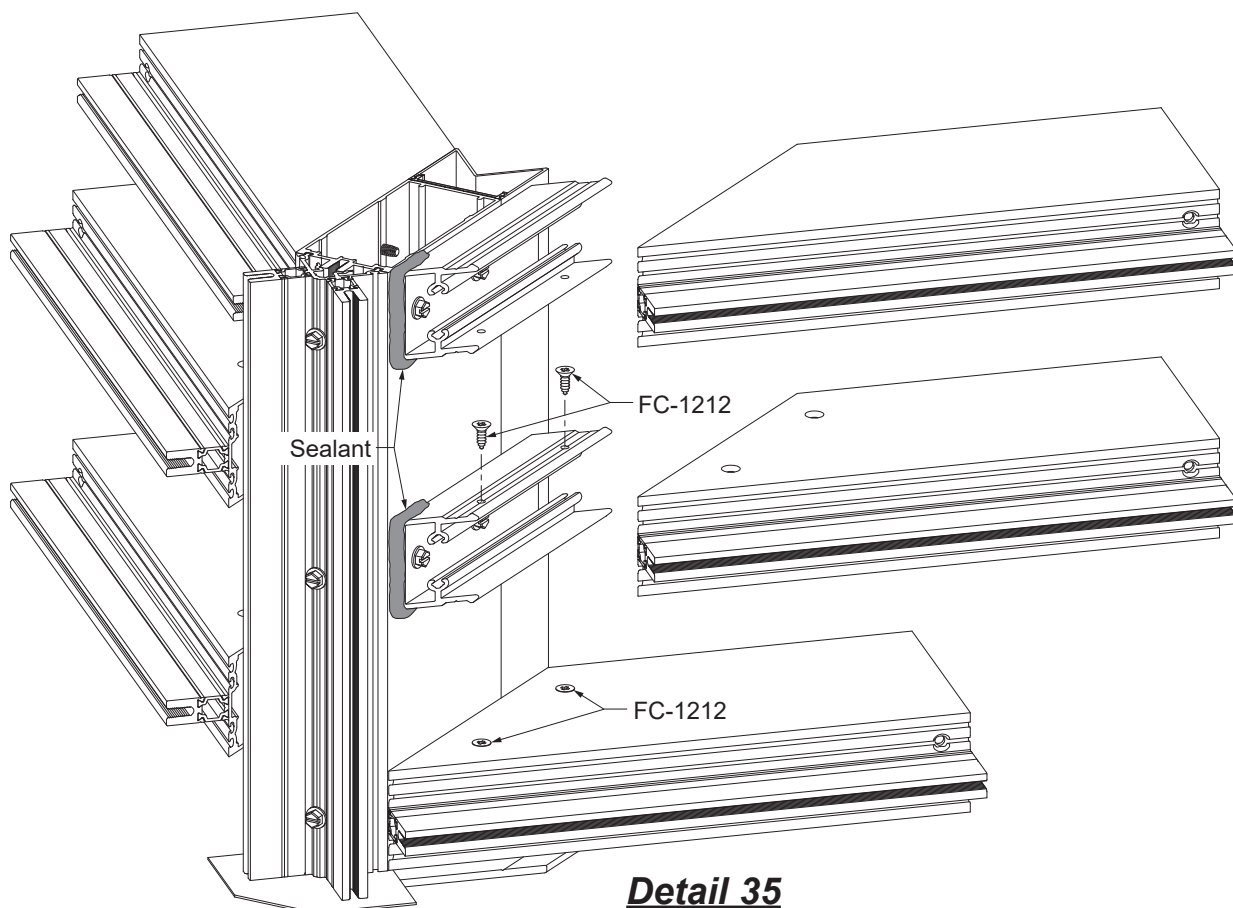



## FRAME INSTALLATION

### STEP 16 (Continued) ATTACH HORIZONTAL MEMBERS

#### Tubular Head & Sill Members:

- Mullion end anchors must be installed before head and sill members are attached.
- Provide anchor fasteners as per approved shop drawings or engineering calculations.
- Install the anchor fasteners as recommended by fastener manufacturer. See **Detail 36**.
- Clean, seal, and attach head and sill members as previously shown on **Page 42**.

**Caution:** A solid shim **must** be placed under the mullion to transfer glazing dead loads to the foundation.

#### TUBULAR HEAD/SILL

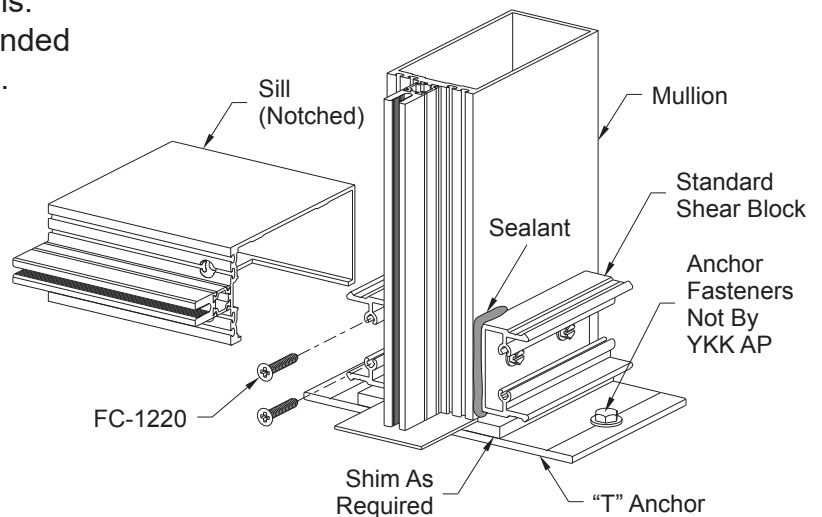

#### **Detail 36**

Sill Shown, Head Similar

## FRAME INSTALLATION

### STEP 17

### INSTALL DOOR SUBFRAMES (35XT/50XT DOORS ONLY\*)

\* **Notes:** 35XT/50XT Doors to be discontinued after April 30, 2024.

Door subframes for 25T/35T/50T doors are installed later during pressure plate installation on **Page 59**.

Doors are shipped assembled, and door sub-frames will be fabricated and shipped knocked down. Refer to the **Entrances Installation Manual** for assembly of the door subframes.

These subframes are typically glazed into the curtain wall framing at the jambs, and set directly upon the sill substrate without any shims. The subframe members are determined by the approved shop drawings.

-Clean all sealant contact surfaces as recommended by the sealant manufacturer.

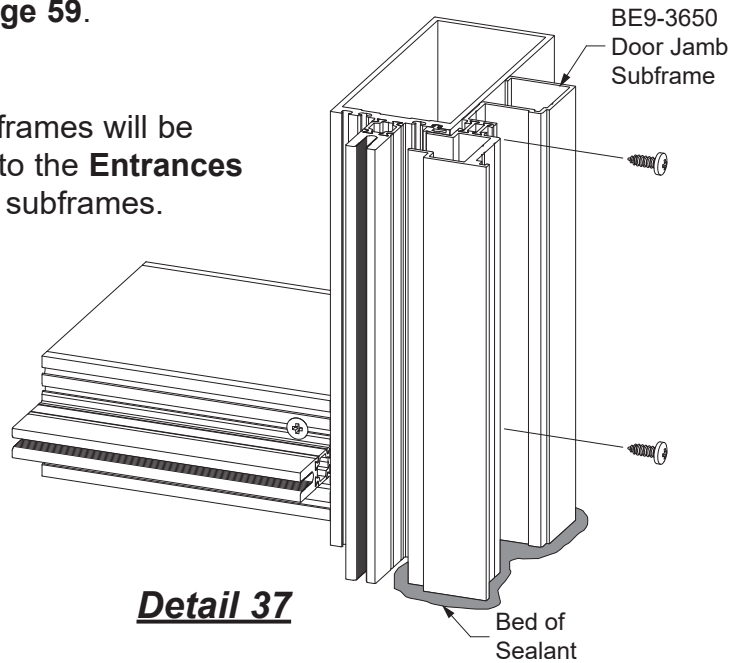

**Detail 37**

-Install the jamb subframe onto the mullion with fasteners according to the approved shop drawings and/or P.E. calculations, setting the subframe jambs in beds of sealant as shown in **Detail 37**.

-Apply and tool sealant to the bottom of the jamb subframe as shown in **Detail 38**.

-Install door stop, BE9-1533 with E2-0051, into the door jambs.

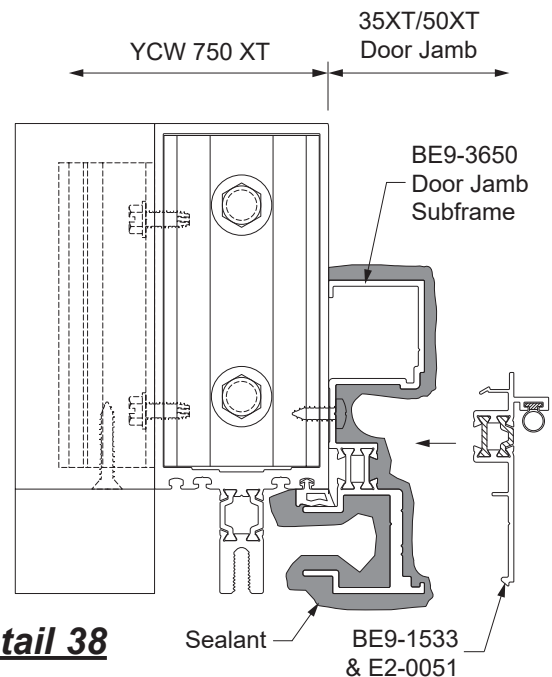

**Detail 38**

## FRAME INSTALLATION

### STEP 18 APPLY PERIMETER SEALANT

- Clean the area around the perimeter of the frame with cleaner and method approved by sealant manufacturer.
  - Insert a backer rod and apply sealant to the perimeter of the frame.
  - Tool the sealant to ensure a water tight joint.
- See **Detail 39**.

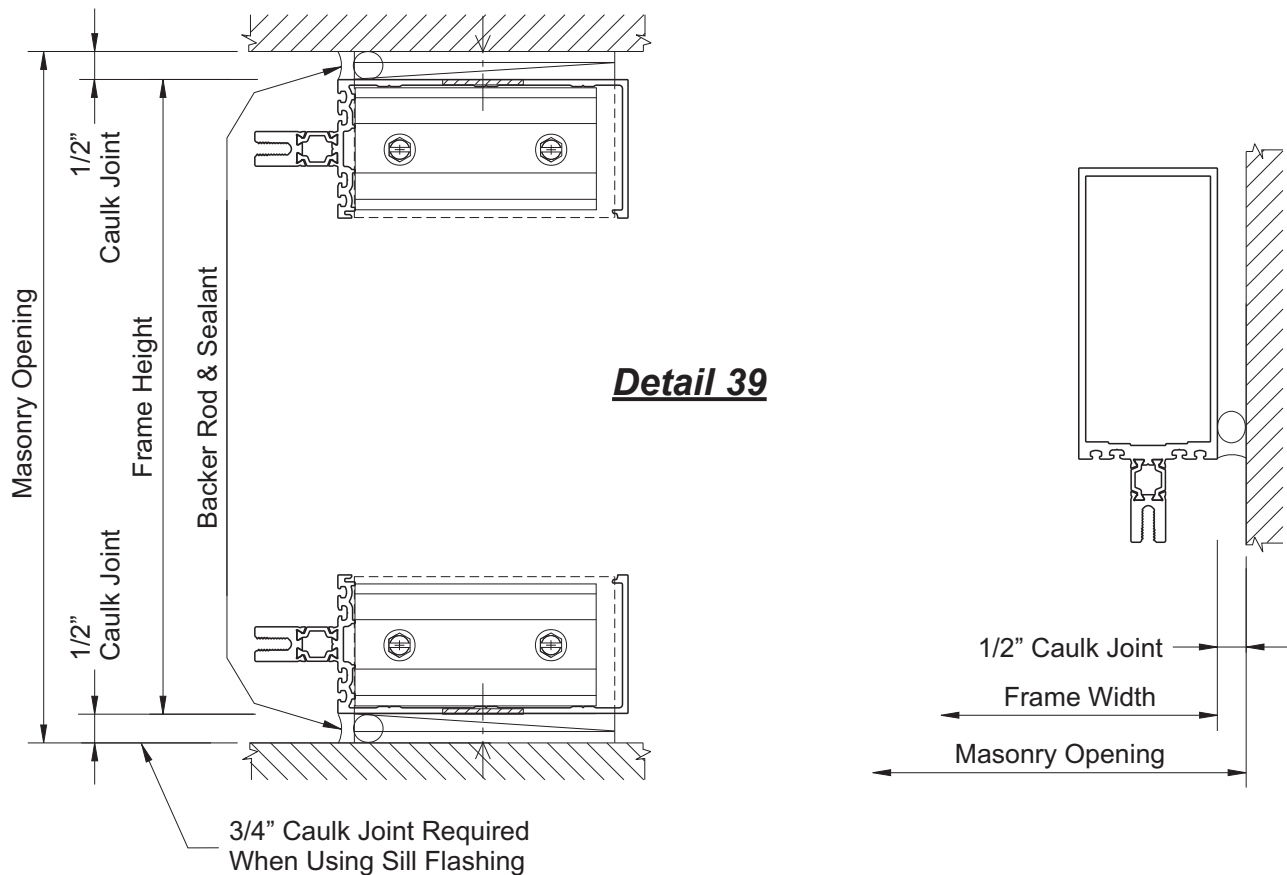

**FRAME INSTALLATION**

**STEP 19 (Optional)  
INSTALL SILL FLASHING**

- Clean the sill flashing ends and mullion end dams with a cleaner and method approved by the sealant manufacturer.
- Apply sealant to the entire face of sill flashing BE9-3918 on both ends prior to installing mullion end cap, E1-3611.

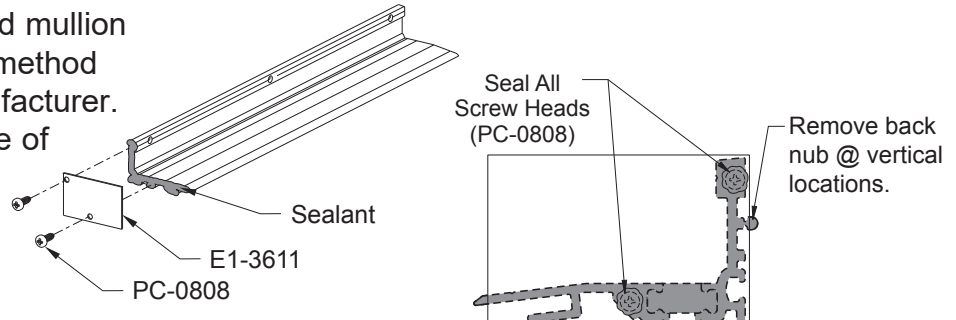

See **Detail 40**.

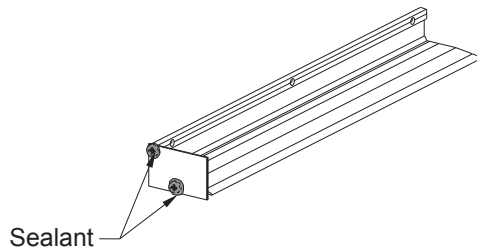

**Detail 40**

- Attach BE9-3918 sill flashing using PC-1010 screws.
- Apply and tool sealant at the sill and sill flashing joint.
- Apply sealant to all screw heads.

See **Detail 41**.

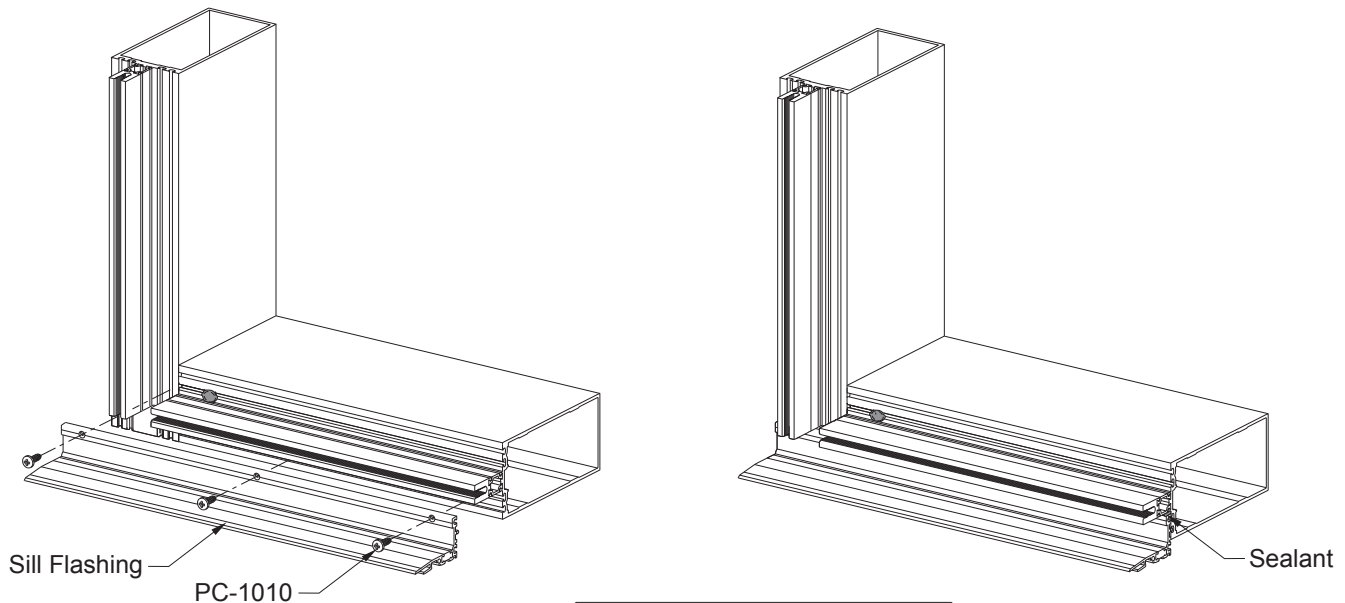

**Detail 41**

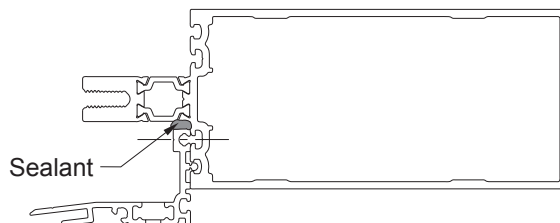

## FRAME INSTALLATION

### STEP 19 (Optional) INSTALL SILL OPTIONAL FLASHING CONT.

- Cut the E2-0070 splice sleeve to the length as shown in **Detail 42**.
- Apply and tool sealant at the sill and sill flashing joint.
- Apply sealant to all screw heads.
- Position the silicone splice sleeve against the back wall below the groove.
- Bend the silicone splice sleeve into the front on the channel as shown. Mark, and cut the sleeve at this position.
- Clean sill flashing and silicone splice sleeve with isopropyl alcohol at the splice location
- Seal the flashing at the splice location before positioning the flashing. Set the silicone splice sleeve into the sill flashing.
- Tool sealant tight, squeezing the sheet flat.
- Thoroughly seal the small joint directly in front of the silicone splice sleeve.

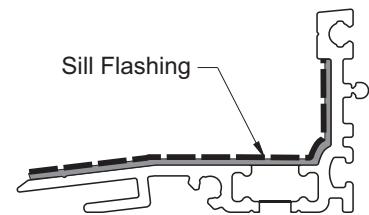

**Detail 42**

See **Details 42 & 43**.

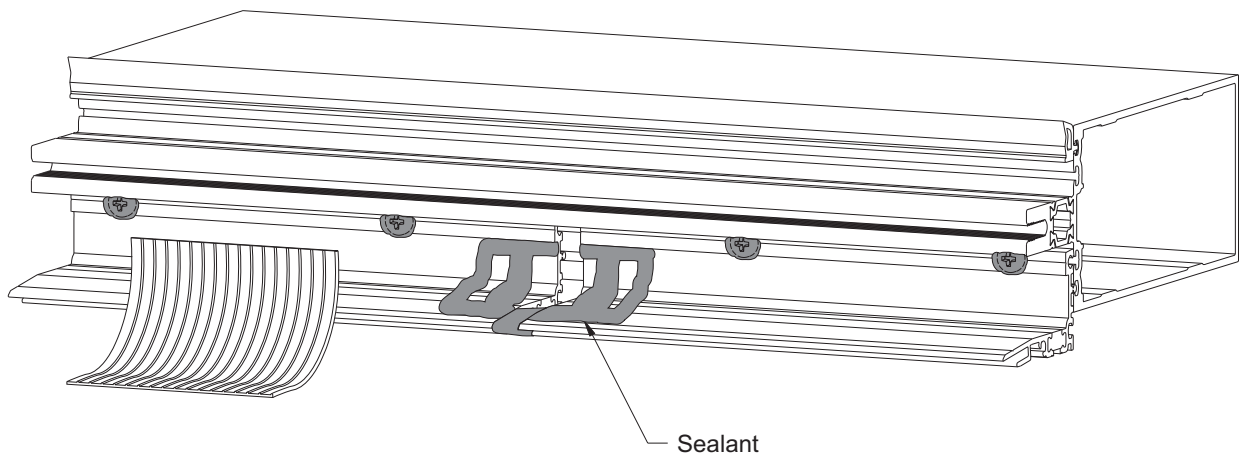

**Detail 43**

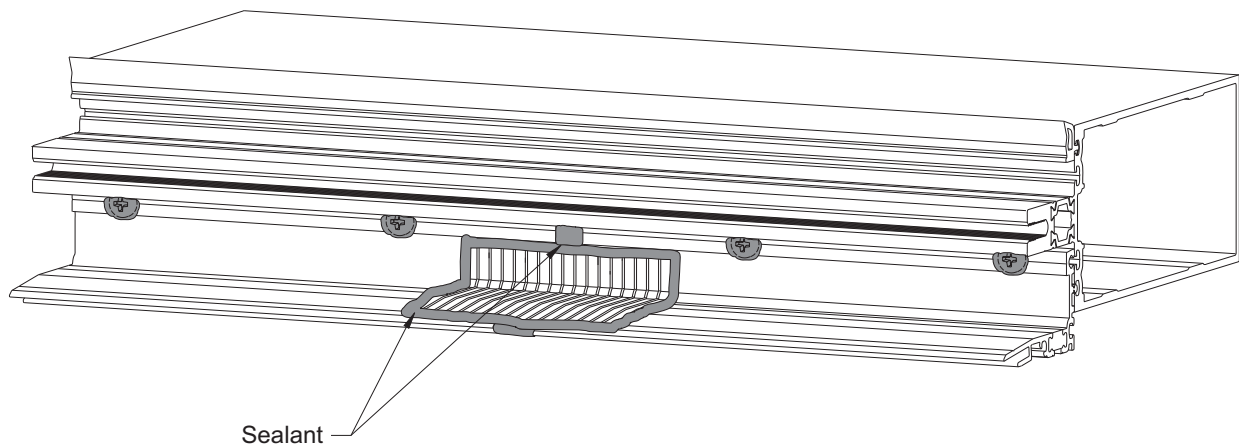

## FRAME INSTALLATION

### STEP 20 INSTALL JOINT PLUGS

The tongue of each head, horizontal and sill must be sealed to the tongue of the mullion and jamb mullions at each end with joint plugs, E2-3603 for 1" glazing, E2-3604 for 1-1/2" glazing and E2-3605 for 2" glazing.

#### For Open Back Sill Members:

- Just prior to installing joint plugs, clean the area around the intersection of the mullion and the sill member with an approved cleaner.
  - Apply and tool sealant to the joint where the sill member meets the mullion and along the joint between the mullion end cap and the perimeter leg of the sill member.
- See **Detail 44**.

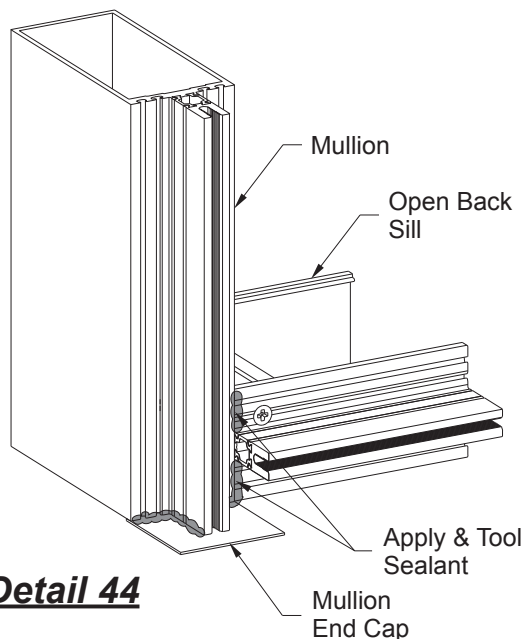

**Detail 44**

- Clean the area around the mullion tongue ends with an approved cleaner.
  - Apply and tool sealant to the joint where the horizontal meets the mullion.
  - Apply sealant to the three contact sides of the joint plug. Fill all glazing reglet cavities in the mullion's front face.
  - Install joint plug as shown with the long leg of the joint plug against the mullion tongue.
  - Press the joint plug firmly against the face of the mullion.
  - Tool the sealant to ensure a watertight seal.
  - Apply and tool sealant over fastener heads on horizontal. Make sure raceway adjacent to fastener head is effectively sealed.
- See **Detail 45**.

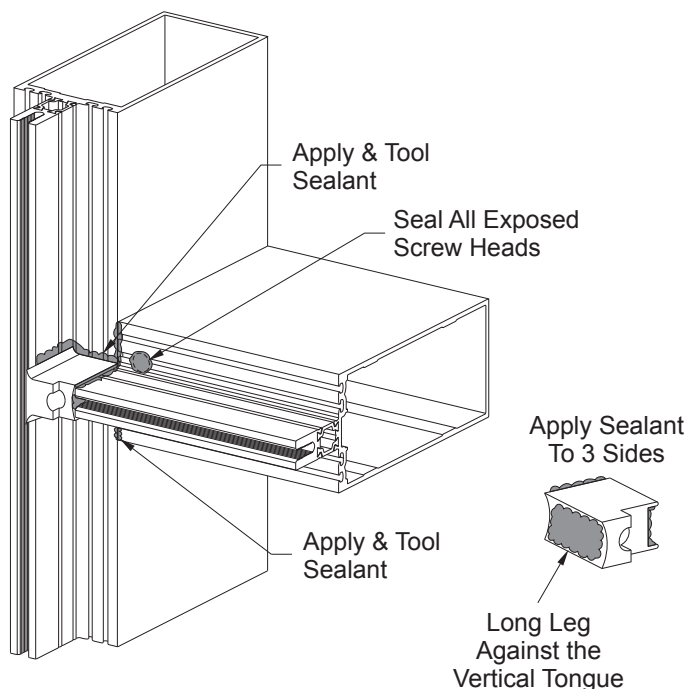

**Detail 45**

Int. Horizontal Shown  
Head & Sill Similar

## FRAME INSTALLATION

### STEP 21 INSTALL 90° OUTSIDE CORNER TRIM

Prior to glazing, install corner trim onto the 90° outside corner mullion.

- Cut E9-9307 angles to the same length as the 90° outside corner mullion adaptor.
- Drill 0.213" diameter holes into the E9-9307 angle at 2" from each end and at 24" maximum on center as shown in **Detail 46**.
- Clamp the angle onto the mullion as shown in **Detail 47**, 3/16" from the edge of the glazing tongue.
- Fasten the angle onto each side of the corner adaptor with PC-1008 screws.

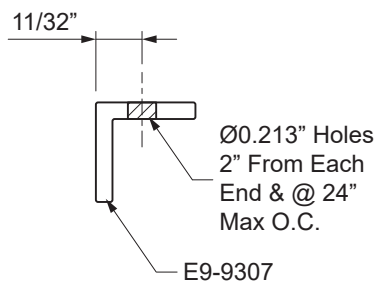

**Detail 46**

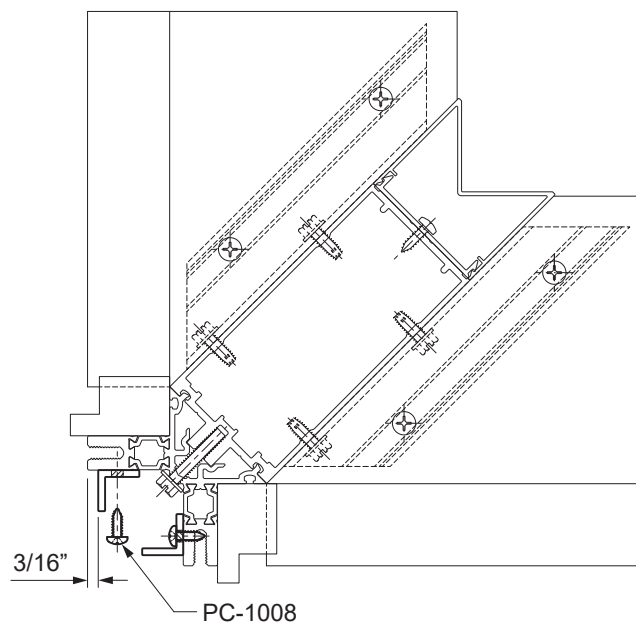

**Detail 47**

**FRAME INSTALLATION****STEP 21 (Continued)****INSTALL 90° OUTSIDE CORNER TRIM**

-Adhere E2-0679 continuous structural tape to the installed E9-9307 angles as shown in **Detail 48**.

-Cut the outside trim angle (E9-9303 for 1" glazing or 1/8" formed aluminum for other glazing thicknesses) to the length of the 90° outside corner mullion adaptor.

-Then firmly adhere the outside trim angle onto the structural glazing tape on both sides.

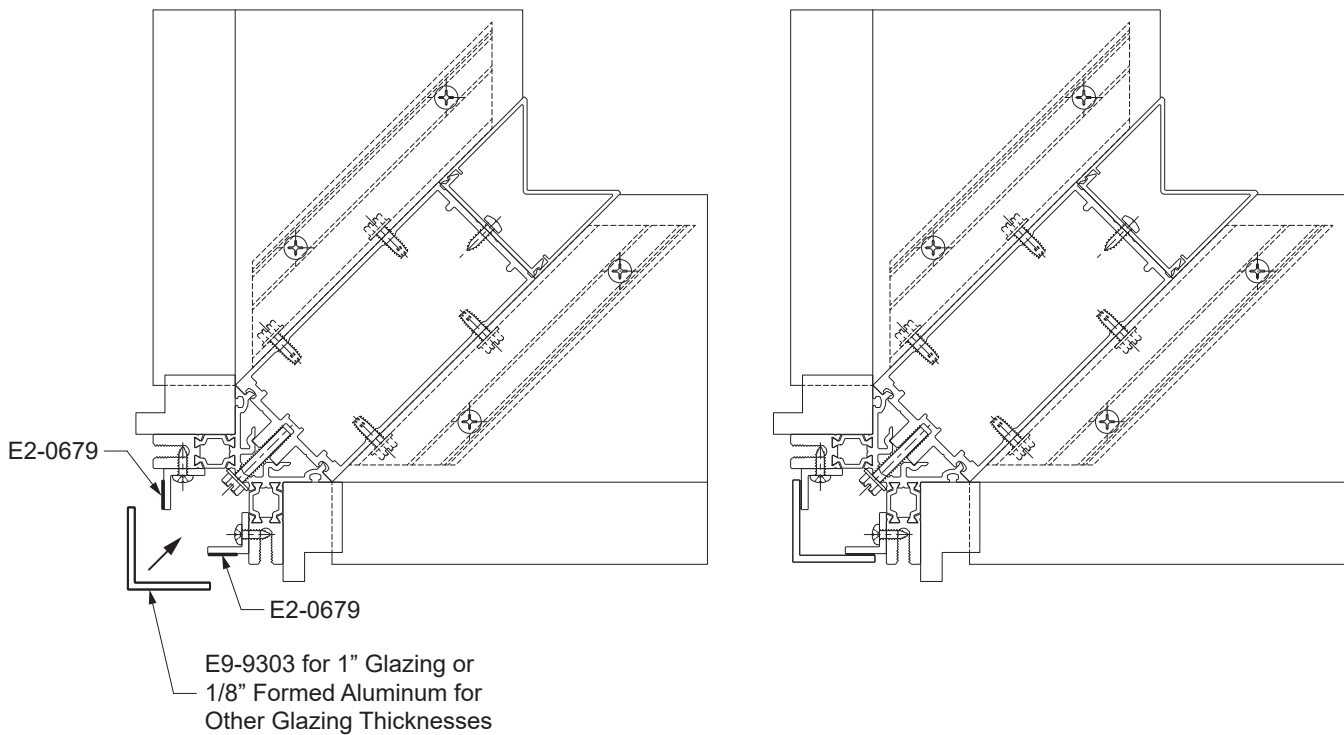
**Detail 48**



## GLAZING

### STEP 22 (Optional) INSTALL GLAZING ADAPTORS

**Note:** 1/4" glazing adaptor for 1" glazing, E9-1220 shown.  
1/4" glazing adaptor for 1-1/2" glazing, E9-3936 similar.  
1/4" glazing adaptor for 2" glazing, E9-3937 similar.

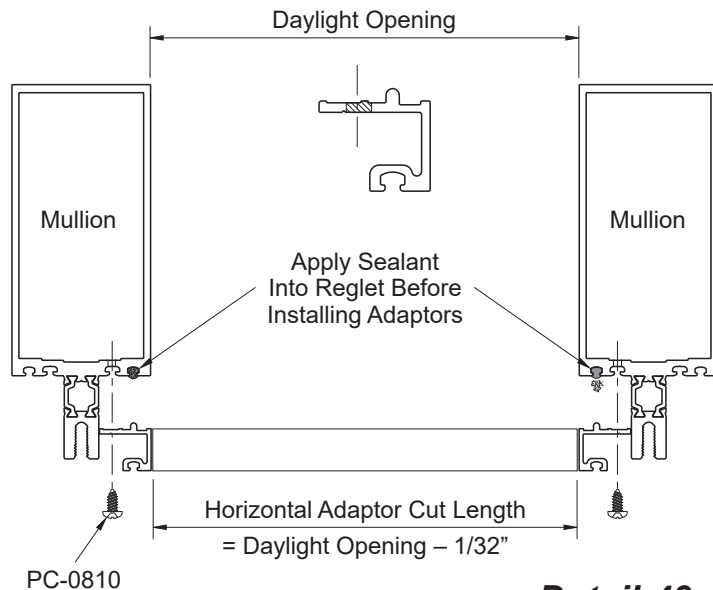

**Detail 49**

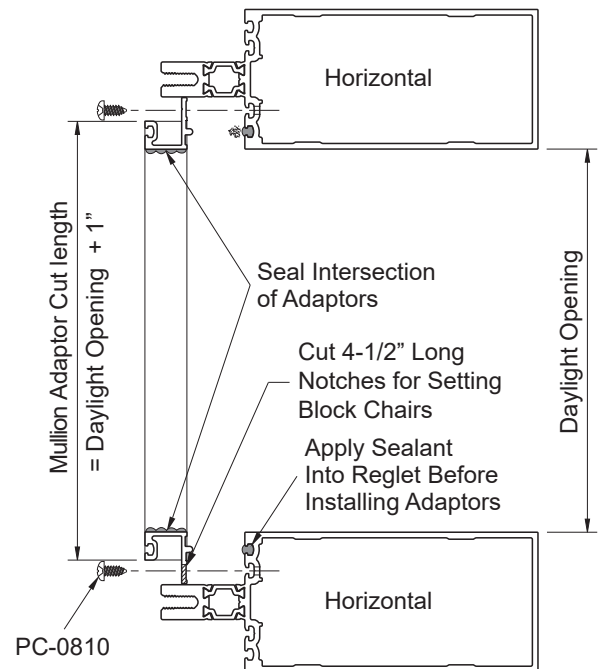

- Cut glazing adaptors to:  
Mullion Cut Length = D.L.O. plus(+) 1".  
Horizontal Cut Length = D.L.O. minus(-) 1/32".

- Predrill each adaptor along the "V"-groove with 0.189" dia. holes 2" from each end and 24" O.C.
- Dry fit adaptors and match drill 0.141" dia. holes on the mullion to receive PC-0810 fasteners.
- Clean the area around the mullion glazing reglet and the glazing adaptor with a cleaner approved by the sealant manufacturer.
- Apply sealant into the glazing reglet of the mullion and the ends of the horizontal adaptors.
- Install the adaptors with PC-0810 screws at each hole location. Install the mullion adaptors first; make sure they are centered along the day light opening.
- Tool sealant at all adaptor intersections and seal all screw heads.

See **Detail 49 & 50**.

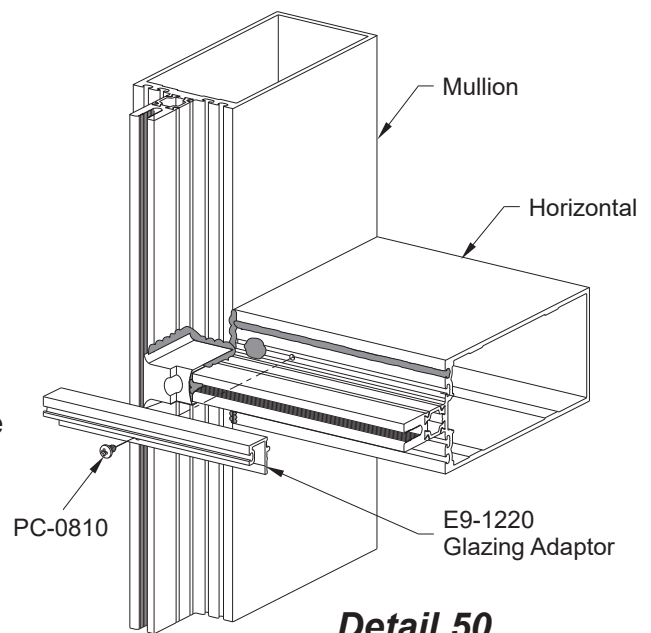

**Detail 50**

**GLAZING****STEP 23****INSTALL INTERIOR GLAZING GASKETS**

- Cut E2-0120 interior glazing gaskets to size:
  - Vertical Gasket = Daylight Opening + 1-1/2".
  - Horizontal Gasket = Daylight Opening + 1/4" per each foot of opening width.
- Install vertical gaskets first, centered along the daylight opening.
- Install horizontal glazing gaskets next.
  - Insert the glazing gasket into the reglet at each end first.
  - Snap the rest of the glazing gasket into the reglet starting at the center and work towards each end.

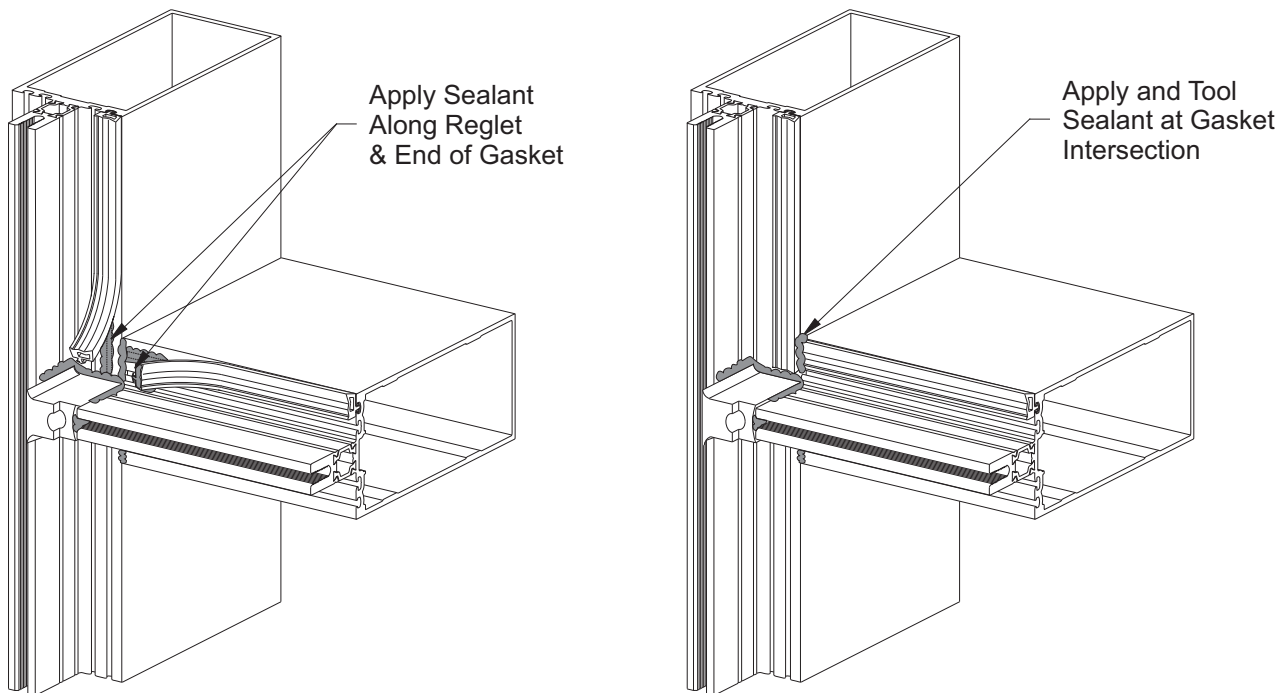
**Detail 51**

- Pull the last 3" of each gasket away from the reglet.
  - With gasket end held out of the way, run a 2-3" bead of sealant into the reglet at the ends.
  - Apply sealant at the ends of the horizontal gaskets.
  - Reinsert the ends of the gaskets pressing them firmly against the face of the mullions.
  - Apply and tool sealant at the intersection of the vertical and horizontal gaskets.
- See **Detail 51**.

## GLAZING

### STEP 24

### INSTALL SETTING BLOCK CHAIRS AND SETTING BLOCKS

**Note:** For correct placement of setting block chairs and setting blocks, see **Detail 53** on **Page 56**. Consult YKK AP for setting block requirements on units that exceed 60" x 90" or 40 sq. ft.

-Install the setting block chair at 1/4 points as shown in **Detail 52**.

-Apply a small amount of silicone sealant to the tongue of the horizontal to keep the setting block chair correctly positioned prior to the glass being set.

-Place the setting block on setting block chair.

See **Detail 52**.

Glazing	Setting Block Chair	Setting Block
1"	E1-3603	E2-0513
1-1/2"	E1-3604	E2-3601
2"	E1-3604	E2-3602

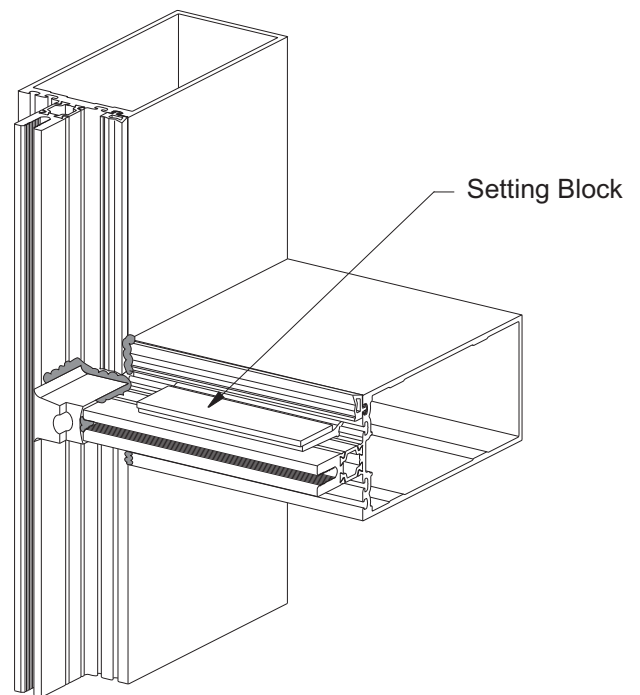
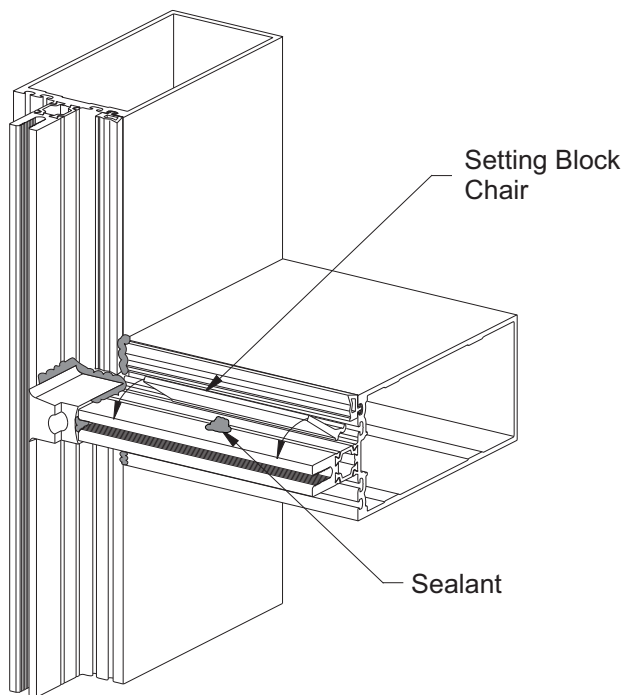

**Detail 52**

**GLAZING**

**STEP 25  
INSTALL SIDE BLOCKS**

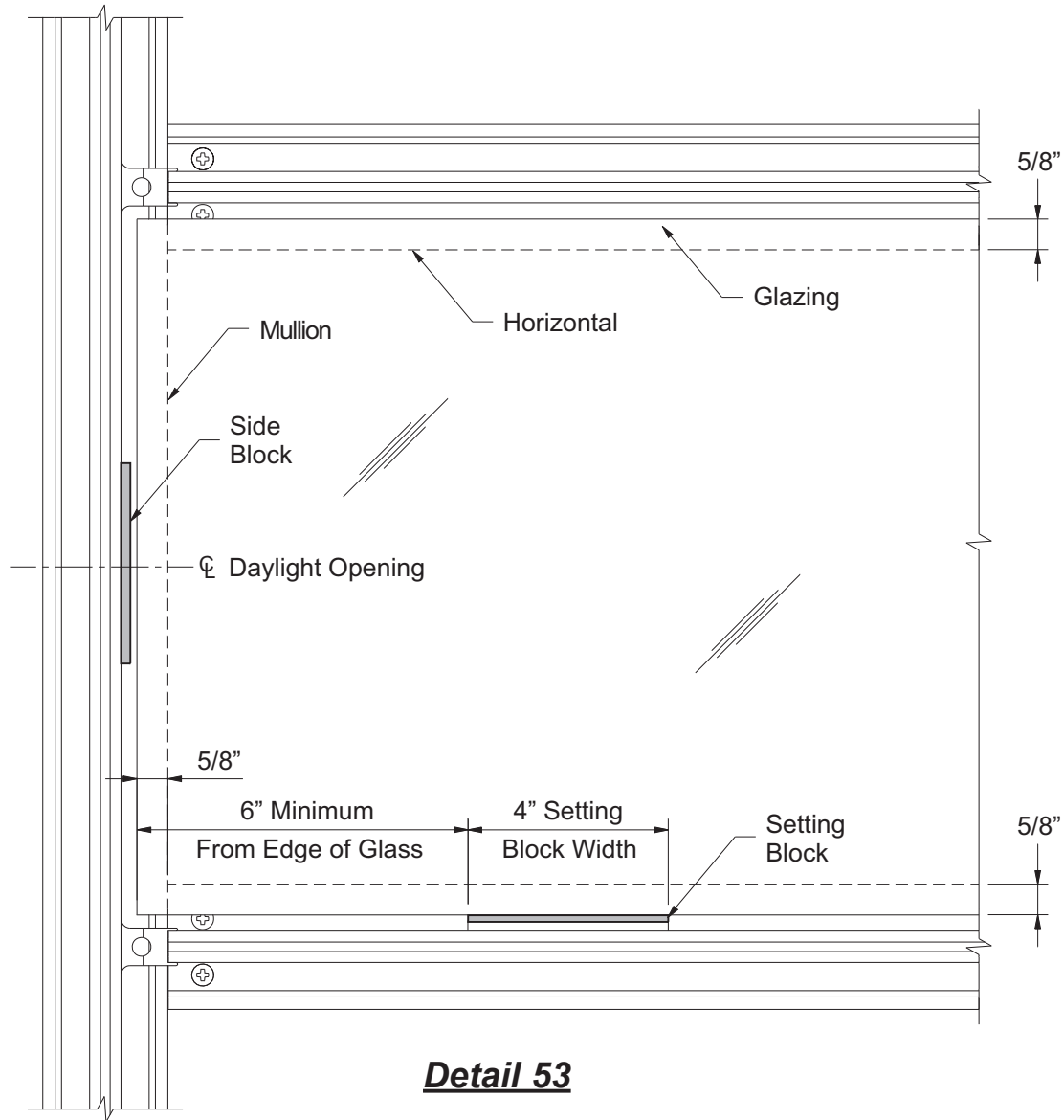

-Install side blocks, E2-0133, centered along the daylight opening on both sides of glazing material.  
See **Detail 53**.

## GLAZING

### STEP 26 INSTALL EXTERIOR GLAZING GASKETS

- Cut E2-0120 exterior vertical glazing gaskets to the same length as the vertical pressure plates. Note that pressure plates used on the corner mullion will have E2-0354 gaskets covering the corner trim.
  - Cut E2-0120 exterior horizontal glazing gaskets to daylight opening plus 1/4" per foot of opening width.
  - Install vertical glazing gaskets onto the vertical pressure plates.
  - Install horizontal gaskets by pushing each end into the reglet of the pressure plate. Next press center of gasket into reglet; then push gasket into reglet working from center towards the ends.
- Caution:** Do not stretch the gaskets.

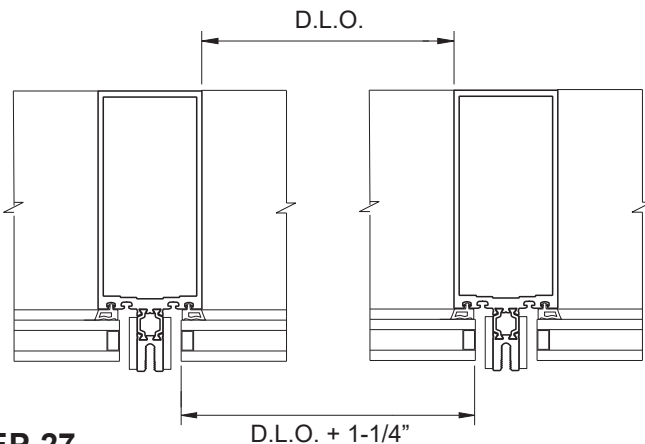

**Detail 54**

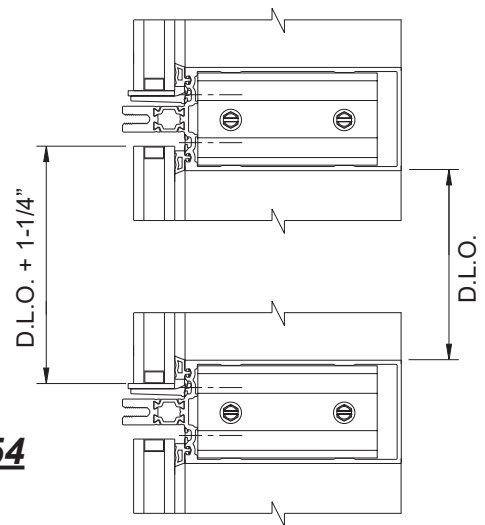

### STEP 27 INSTALL GLASS

**Glass and Spandrel Size = Daylight Opening + 1-1/4" Horizontally and Vertically.**

- As each lite is installed, attach a temporary retaining clip, E1-3612, in the middle of each horizontal and 4" from glass edge at each end using HD-2516-W3-SS fasteners.
- Reuse the temporary retaining clips.
- Apply sealant to the face of the joint plugs just prior to installing vertical pressure plates. Do not allow sealant to skin over prior to installing pressure plates.

**Note:** Sealant must form a complete seal between the exterior gasket, pressure plate, thermal isolator, and the joint plug.

See **Detail 54 & 55.**

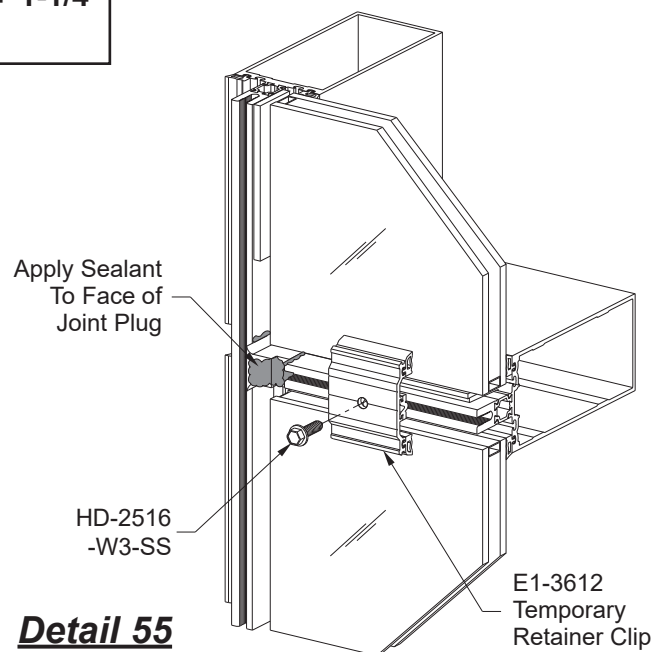

**Detail 55**

## GLAZING

### STEP 28 PRESSURE PLATE LAYOUT AND ASSEMBLY

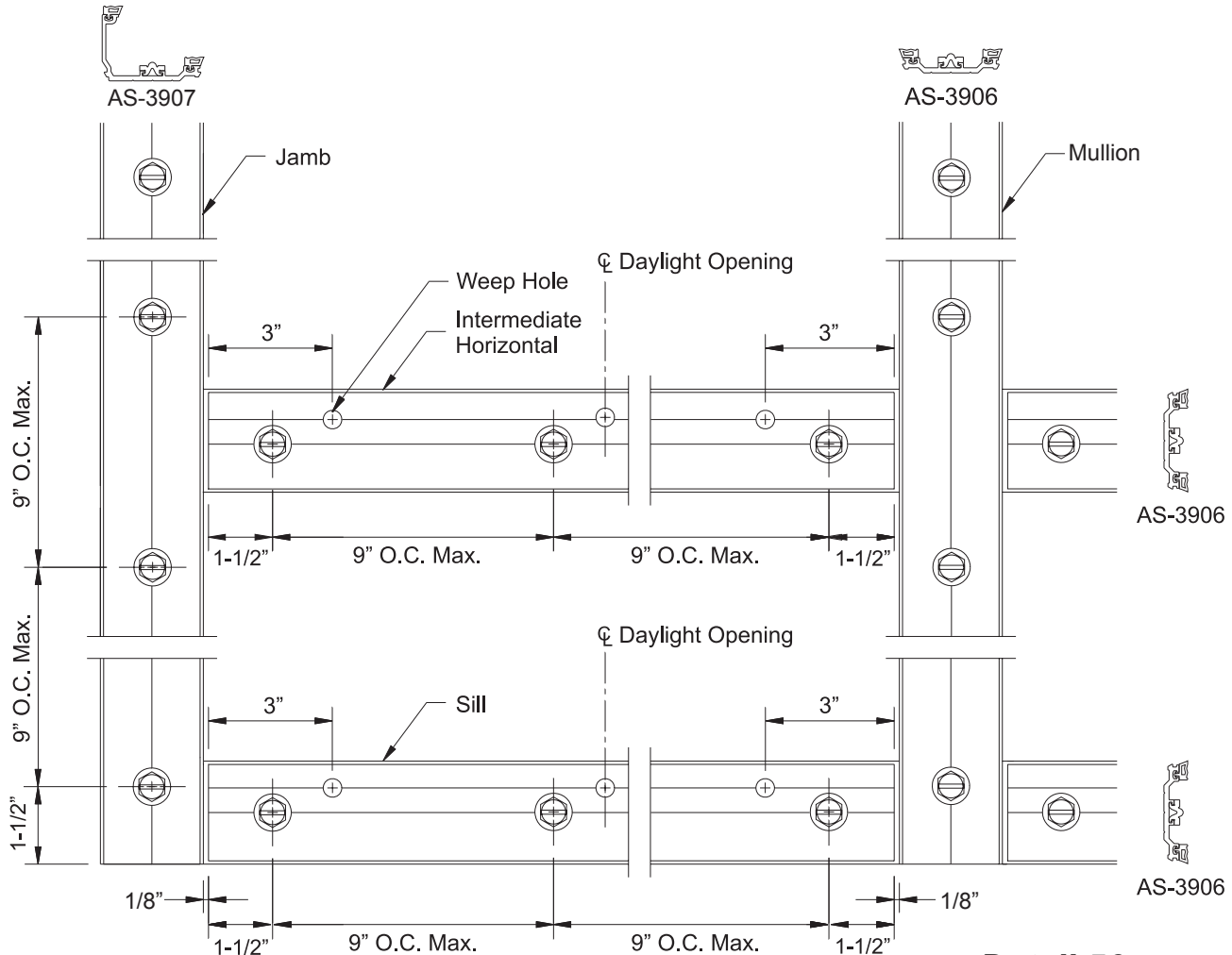

***Detail 56***

-Pressure plate stock lengths are factory punched with 0.281" diameter holes at 9" O.C. maximum. After cutting, additional holes may be required to have fasteners 1-1/2" from each end. Seal over holes less than 1-1/2" from the ends.

See **Detail 56**.

-Install vertical pressure plates using HD-2516-W3-SS screws. Initially torque screws to 30 inch-pounds with a torque limiting screw gun. Work from the bottom up.

**Note:** The vertical gasket **MUST** clear the tongue of the horizontal mullion.

-Torque all vertical pressure plate screws to 50-inch pounds. Do not over-torque.

-Install vertical face cover E9-1206 using a mallet and a clean scrap piece of lumber. Start at one end and work down the vertical.

See **Detail 59** on **Page 60**.

-Center and install horizontal pressure plates in opening, leaving a 1/8" gap at the ends.

-Starting at the center of each pressure plate, tighten each retainer screw to 50 inch-pounds.

## GLAZING

### STEP 29 INSTALL FLAT DOOR JAMB SUBFRAME FOR 25T/35T/50T DOORS

Vertical pressure plates at the door jamb are installed first to ensure proper sealant application.

-Install a perimeter pressure plate (or a pressure plate with pocket filler) onto the mullion in a bed of sealant on the substrate using HD-2516-W3-SS fasteners. See **Detail 57**.

-Install the BE9-1526 flat subframe onto the mullion also in a bed of sealant using fasteners as indicated on the approved shop drawings or engineering calculations. Set the exterior face of the subframe is 3/8" behind the face of the vertical pressure plate. This will ensure a 1/4" inset behind the face cover once installed. See **Detail 58 & 58A**.

**Note:** A minimum 1/4" shim space is required at the door jamb.

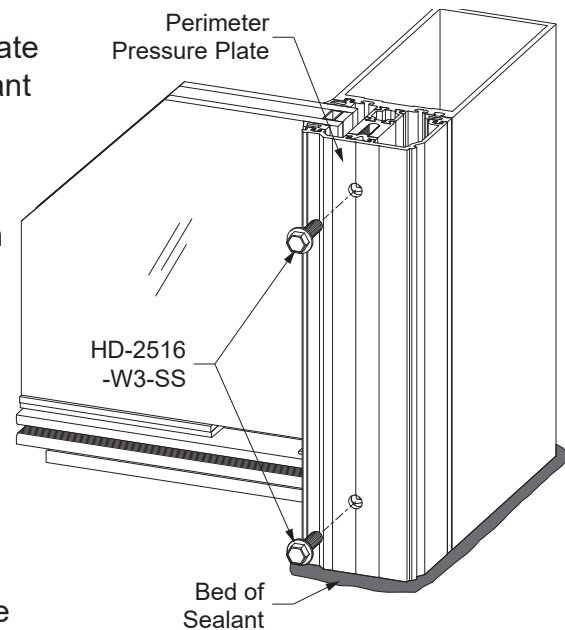

**Detail 57**

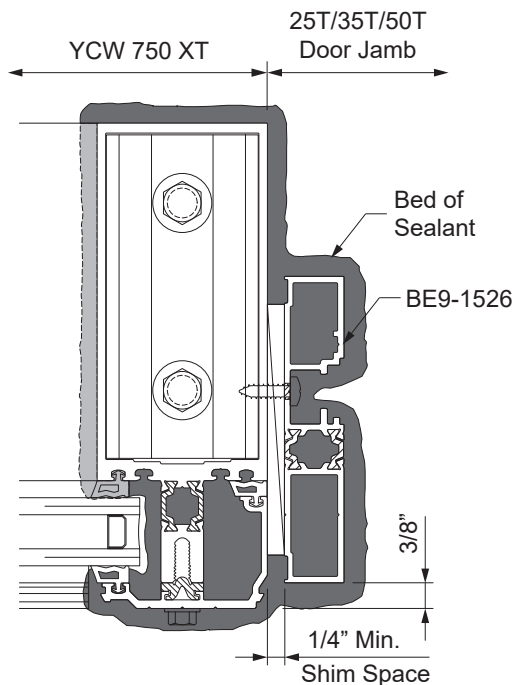

**Detail 58**

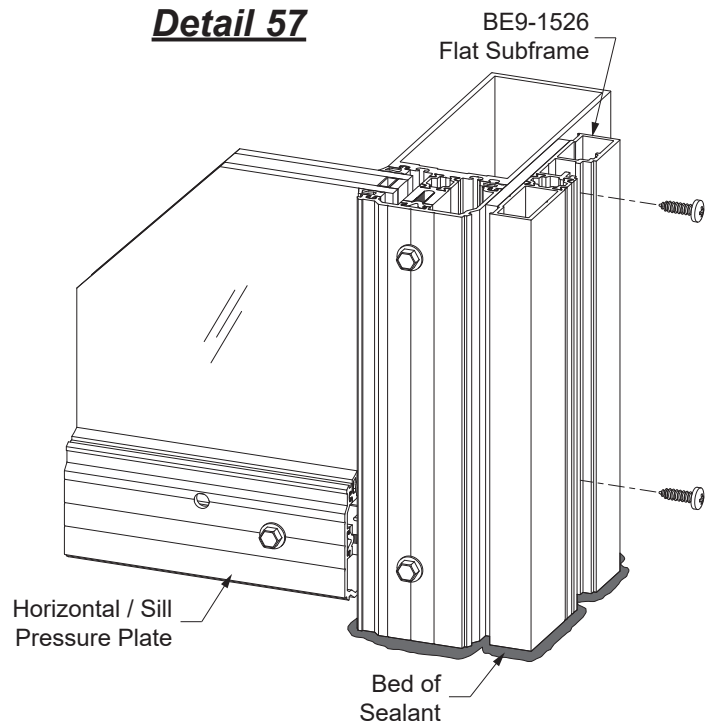

**Detail 58A**

**GLAZING**

**STEP 30  
INSTALL EXTERIOR FACE COVERS**

- Apply and tool sealant to completely seal between the ends of the horizontal pressure plates and vertical covers. See **Detail 59**.
- Install horizontal face cover E9-1206.
- Snap on horizontal face covers using a mallet and a clean scrap piece of lumber. Start at one end and work across the horizontal. See **Detail 60**.

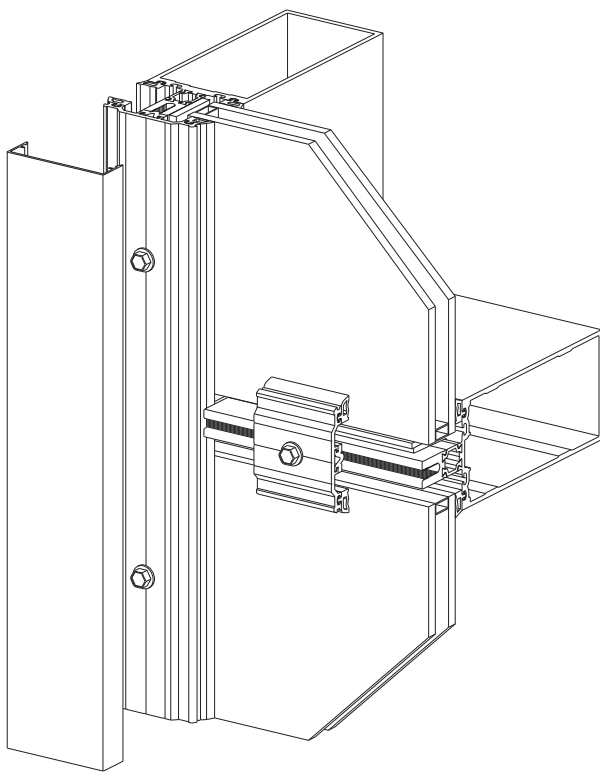

**Detail 59**

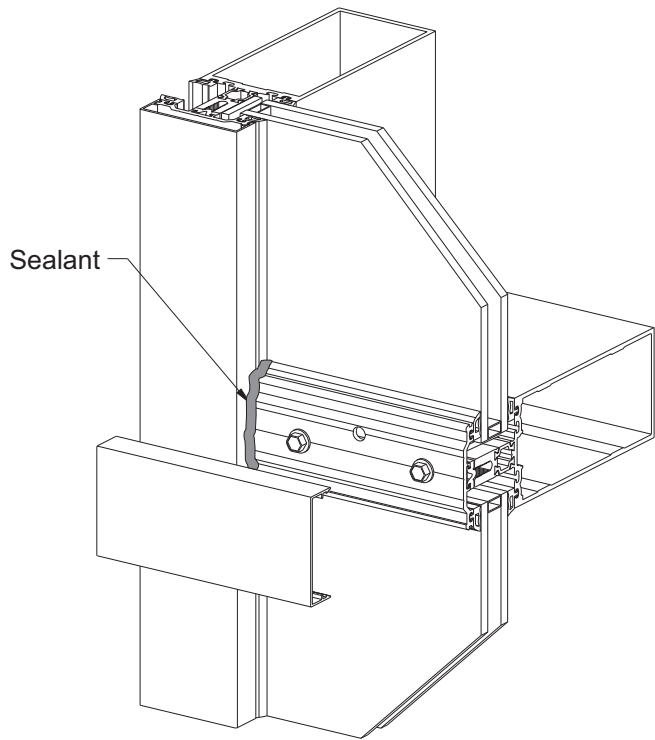

**Detail 60**

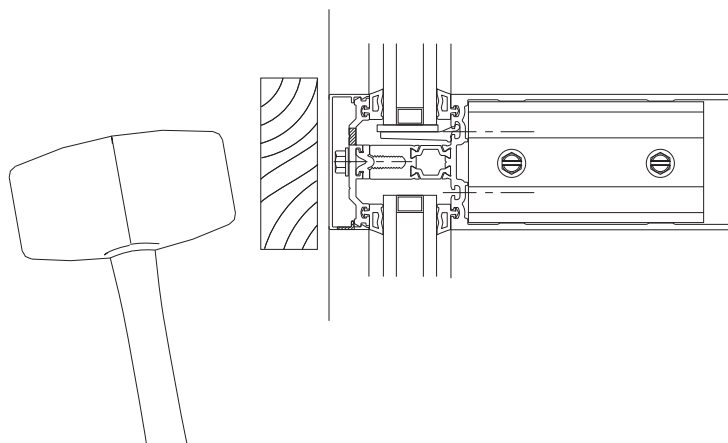



## DOOR SUBFRAME INSTALLATION

### STEP 31 INSTALL DOOR STOP FOR 25T/35T/50T DOORS

- After face cover installation, apply sealant at both the interior and exterior joint space between the mullion and the subframe,
- Snap on the AS-1539 door stop.

See **Detail 61**.

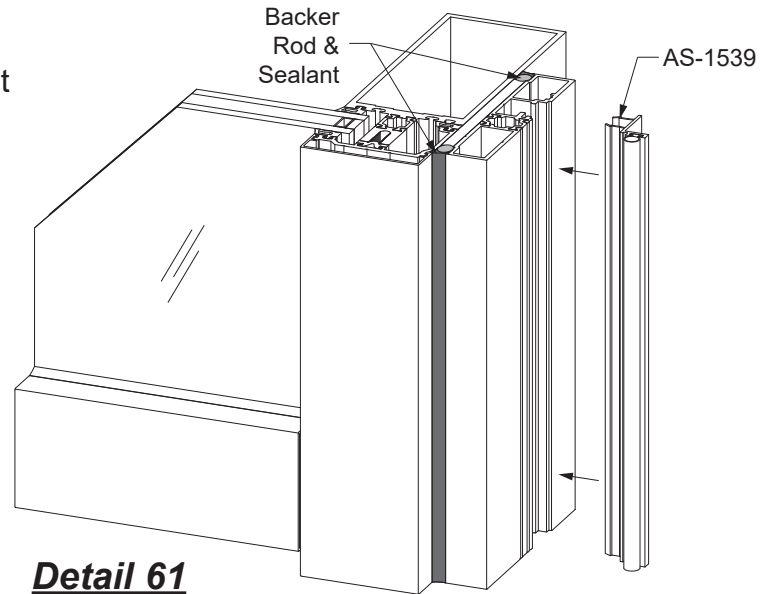

### STEP 32 FASTEN DOOR SUBFRAME AT TRANSOM

Horizontals at the door transom are largely the same as regular horizontals. For YCW 750 XT, the transom bar can be fastened into the perimeter pressure plate or the horizontal mullion itself.

See **Detail 62**.

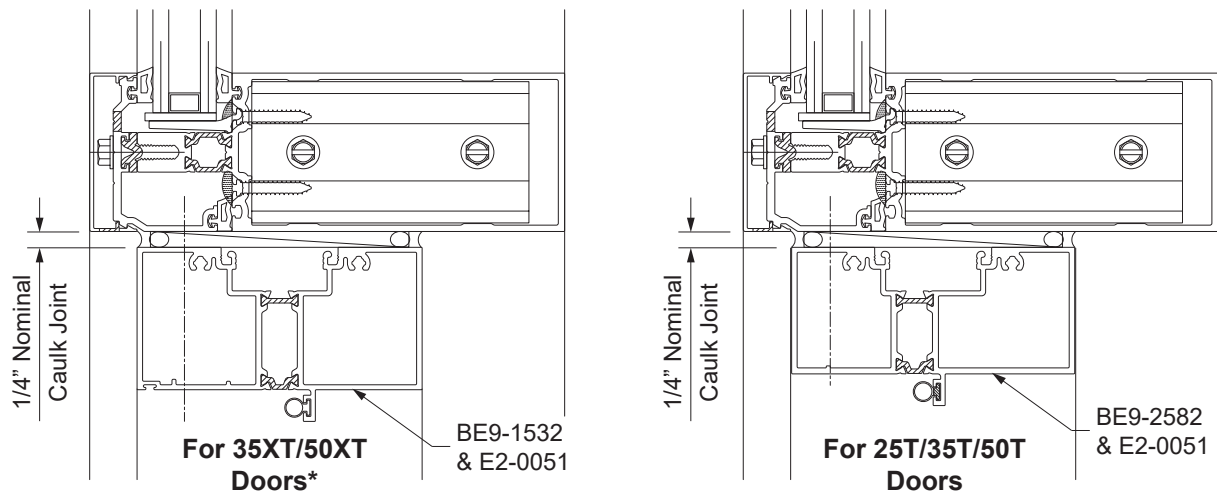

**\*Note:** 35XT/50XT Doors to be discontinued after April 30, 2024.

**Detail 62**



101 Marietta Street NW  
Suite 2100  
Atlanta Georgia 30303  
[www.ykkap.com](http://www.ykkap.com)