

**YCW Veneer Wall System**

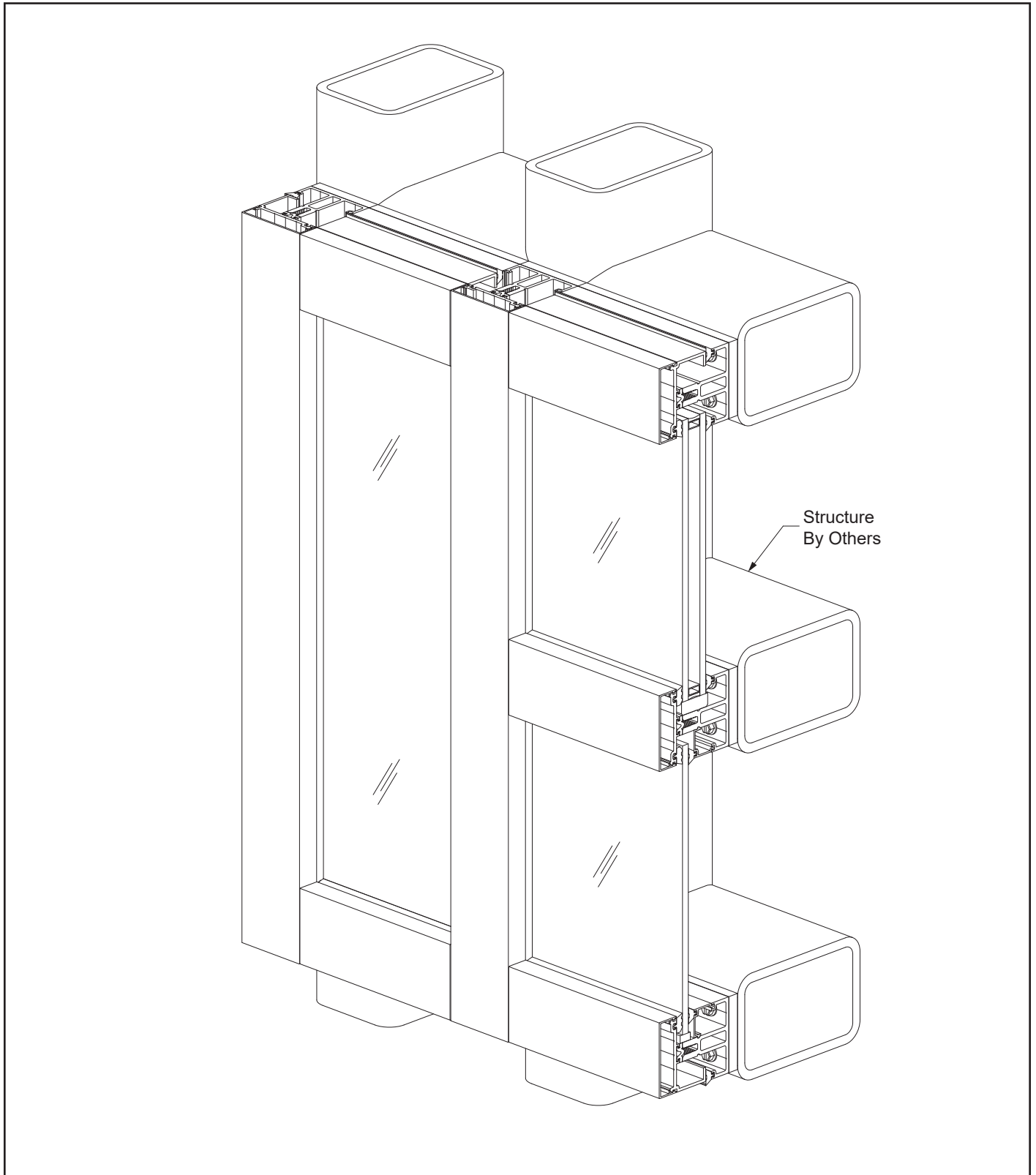

**Installation Manual**



TABLE OF CONTENTS

Installation Notes ..... Page ii

PARTS DESCRIPTION

YCW Veneer Wall Members ..... Pages 1 & 2
YCW Veneer Wall Accessories ..... Page 3
YCW Veneer Wall Fasteners ..... Page 4

FRAME FABRICATION

Anchoring Methods..... Page 5
Fabricate Mullions ..... Page 6
Fabricate Horizontals..... Pages 7 & 8
Fabricate Pressure Plates ..... Page 9
Fabricate Face Covers ..... Page 10

FRAME INSTALLATION

Install Framing ..... Pages 11 to 13
Apply Perimeter Sealant..... Page 14
Install Joint Plugs..... Page 15

















GLAZING

Install Glazing Adaptors..... Page 16
Install Interior Glazing Gaskets ..... Page 17
Install Setting & Side Blocks ..... Page 18
Install Exterior Glazing Gaskets ..... Page 19
Install Glass ..... Page 19
Pressure Plate Layout and Assembly ..... Pages 20 & 21
Install Exterior Face Covers ..... Pages 22 & 23











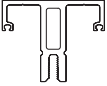



## Installation Notes

1. Do not drop, roll or drag boxes of aluminum framing. Move and stack boxes with proper support to prevent distortion. If fork lifts are used be especially careful about striking the boxes when lifting or moving.
2. Store in a dry, out of the way area. If rain exposure, condensation or any water contact is likely, then all packaging material should be removed. Wet packaging materials will discolor and may stain aluminum finishes and paints.
3. All materials should be checked for quality and quantity upon receipt, YKK AP must be notified immediately of any discrepancies in shipment. Check to make sure that you have the required shims, sealants, supplies and tools necessary for the installation.
4. Carefully check the openings and surrounding conditions that will receive your material. Remember, if the construction is not per the construction documents, it is your responsibility to notify the general contractor in writing. Any discrepancies must be brought to the general contractor's attention before you proceed with the installation.
5. Gather your shop drawings, materials, packing list, and this installation manual. Carefully review parts location, the sequence it goes therein, when you glaze it and how you seal it. Installation instructions are of a general nature and may not cover every condition you will encounter. The shop drawings and/or installation manuals were prepared specifically for the product.
6. Any material substitutions must be of equal or greater quality.
7. Make certain that material samples have been sent for compatibility testing for all manufacturer's sealants involved. Make certain sealants have been installed in strict accordance with the manufacturer's recommendations and specifications.
8. Remember to isolate, in an approved manner, all aluminum from uncured masonry or other incompatible materials.
9. System-to-structure fasteners are not supplied by YKK AP. Fasteners called out on shop drawings are to indicate minimum sizes for design loading.
10. If any questions arise concerning YKK AP products or their installation, contact YKK AP for clarification before proceeding.
11. YKK AP storefront and/or curtain wall framing is typically completed before drywall, flooring and other products which may still be in process. Take the extra time to wrap and protect the work produced.
12. Cutting tolerances are plus zero, minus one thirty second unless otherwise noted.
13. Check our website, [www.ykkap.com](http://www.ykkap.com), for the latest installation manual update prior to commencing work.















2" FRAMING MEMBERS

	<b>2" x 1" Vertical/Horizontal Mullion</b> For 1/4" Glazing	<b>E9-1661</b>		<b>2" Perimeter Pressure Plate</b> For 1" Glazing	<b>AS-1616</b>
	<b>2" x 1-1/2" Vertical / Horizontal Mullion</b> For 1" & 1/4" Glazing	<b>E9-1650</b>		<b>2" Perimeter Pressure Plate w/ Tape</b> For 1" Glazing	<b>AS-1667</b>
	<b>4" x 1-1/2" Vertical / Horizontal Mullion</b> For 1" & 1/4" Glazing	<b>E9-1664</b>		<b>4" Perimeter Pressure Plate</b> For 1" Glazing	<b>AS-1655</b>
	<b>2" Pressure Plate</b> For 1" & 1/4" Glazing	<b>AS-1601</b>		<b>Glazing Adaptor</b> For 1/4" Glazing	<b>E9-1651</b>
	<b>4" Pressure Plate</b> For 1" & 1/4" Glazing	<b>AS-1654</b>		<b>2" x 5/8" Face Cover</b>	<b>E9-1602</b>
	<b>2" Perimeter Pressure Plate</b> For 1/4" Glazing	<b>AS-1662</b>		<b>2" x 1" Face Cover</b>	<b>E9-1617</b>
	<b>2" Perimeter Pressure Plate</b> For 1/4" Glazing	<b>AS-1663</b>		<b>4" x 5/8" Face Cover</b>	<b>E9-1653</b>
	<b>2" Perimeter Pressure Plate w/ Tape</b> For 1/4" Glazing	<b>AS-1666</b>		<b>4" x 3/4" Face Cover</b>	<b>E9-1660</b>





2-1/2" FRAMING MEMBERS

 <p><b>2-1/2" x 1" Vertical/Horizontal Mullion</b> For 1/4" Glazing</p>	<p><b>E9-1260</b></p>	 <p><b>2-1/2" x 1-3/4" Face Cover</b></p>	<p><b>E9-1229</b></p>
 <p><b>2-1/2" Pressure Plate</b></p>	<p><b>AS-1216</b></p>	 <p><b>2-1/2" x 2" Face Cover</b></p>	<p><b>E9-1291</b></p>
 <p><b>2-1/2" Perimeter Pressure Plate</b> For 1" Glazing</p>	<p><b>AS-1217</b></p>	 <p><b>2-1/2" x 2-3/8" Face Cover</b></p>	<p><b>E9-1219</b></p>
 <p><b>2-1/2" Pressure Plate</b> For 1/4" Glazing</p>	<p><b>AS-3572</b></p>	 <p><b>2-1/2" x 2" Round Face Cover</b></p>	<p><b>E9-1293</b></p>
 <p><b>2-1/2" Pressure Plate for Deep Cover</b></p>	<p><b>AS-3574</b></p>	 <p><b>2-1/2" x 4-3/8" Face Cover</b></p>	<p><b>E9-1233</b></p>
 <p><b>2-1/2" Perimeter Pressure Plate for Deep Cover</b> For 1" Glazing</p>	<p><b>AS-3576</b></p>	 <p><b>2-1/2" x 5-1/4" Face Cover</b></p>	<p><b>E9-1230</b></p>
 <p><b>Glazing Adaptor</b> For 1/4" Glazing</p>	<p><b>E9-1261</b></p>	 <p><b>2-1/2" x 5-7/8" Face Cover</b></p>	<p><b>E9-3503</b></p>
 <p><b>2-1/2" x 3/4" Face Cover</b></p>	<p><b>E9-1206</b></p>		

ACCESSORIES

 <p><b>Splice Sleeve</b> For E9-1206 Face Cover</p>	<p><b>E1-1202</b></p>	 <p><b>Side Block</b> For 2" Framing</p>	<p><b>E2-0133</b></p>
 <p><b>Splice Sleeve</b> For E9-1602 Face Cover</p>	<p><b>E1-1252</b></p>	 <p><b>Side Block</b> For 1/4" Glazing, 2" Framing</p>	<p><b>E2-0624</b></p>
 <p><b>Joint Plug</b> For 1" Glazing, 2" Framing</p>	<p><b>E2-0138</b></p>	 <p><b>Interior Dart Gasket</b></p>	<p><b>E2-0136</b></p>
 <p><b>Joint Plug</b> For 1/4" Glazing, 2" Framing</p>	<p><b>E2-0285</b></p>	 <p><b>Setting Block</b> For 1" Glazing, 2" Framing</p>	<p><b>E2-0134</b></p>
 <p><b>Joint Plug</b> For 2-1/2" Framing</p>	<p><b>E2-0205</b></p>	 <p><b>Exterior Dart Gasket</b></p>	<p><b>E2-0139</b></p>
 <p><b>Setting Block</b> For 1" Glazing, 2-1/2" Framing</p>	<p><b>E2-0104</b></p>	 <p><b>Isolator Tape</b> (For AS-3576 Perimeter Pressure Plate)</p>	<p><b>E2-0239</b></p>
 <p><b>Side Block</b> For 2-1/2" Framing</p>	<p><b>E2-0105</b></p>	 <p><b>Setting Block</b> For 1/4" Glazing</p>	<p><b>E2-0623</b></p>

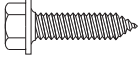
## FASTENERS

	<p><b>#8 x 3/8" PHMSM</b> Type AB, Zinc Plated Steel For Attachment of Glazing Adaptor E9-1604</p>	<p><b>PC-0806</b></p>		<p><b>#8 x 1/2" PHMSM Type F</b> Stainless Steel For Attachment of Face Cover Splice Sleeves</p> <p><b>PF-0808 -SS</b></p>
	<p><b>#8 x 1/2" FHSMS</b> Type AB, Stainless Steel Undercut For Attachment of Face Cover Splice Sleeve</p>	<p><b>FC-0808 -SS</b></p>		<p><b>1/4"-20 x 1" HWHMS</b> Type CA, Stainless Steel For Attachment of Pressure Plate to Mullion</p> <p><b>HD-2516 -W3-SS</b></p>
	<p><b>#8 x 1/2" PHMSM</b> Type AB, Stainless Steel For attachment of Deep Face Cover at Exposed Location</p>	<p><b>PC-0808 -SS</b></p>		



## FRAME FABRICATION

**Fabrication of YCW Veneer varies depending on the size and spacing of the anchor bolts specified on the approved shop drawings:**

**Note:** If YKK AP does not prepare the shop drawings for the project, a qualified engineer must approve all anchors, their arrangement, and mullion selection.

All anchors must be attached to structurally sound material that will accommodate the anchor reactions.

**Installation Sequence:** Install an end vertical first, then butt all the horizontals to that end vertical. Butt the next vertical to the installed horizontal followed by the next bay of horizontals.

When using stick build construction, check overall frame width every fifth mullion as the wall is installed to prevent the buildup of cumulative tolerance errors.

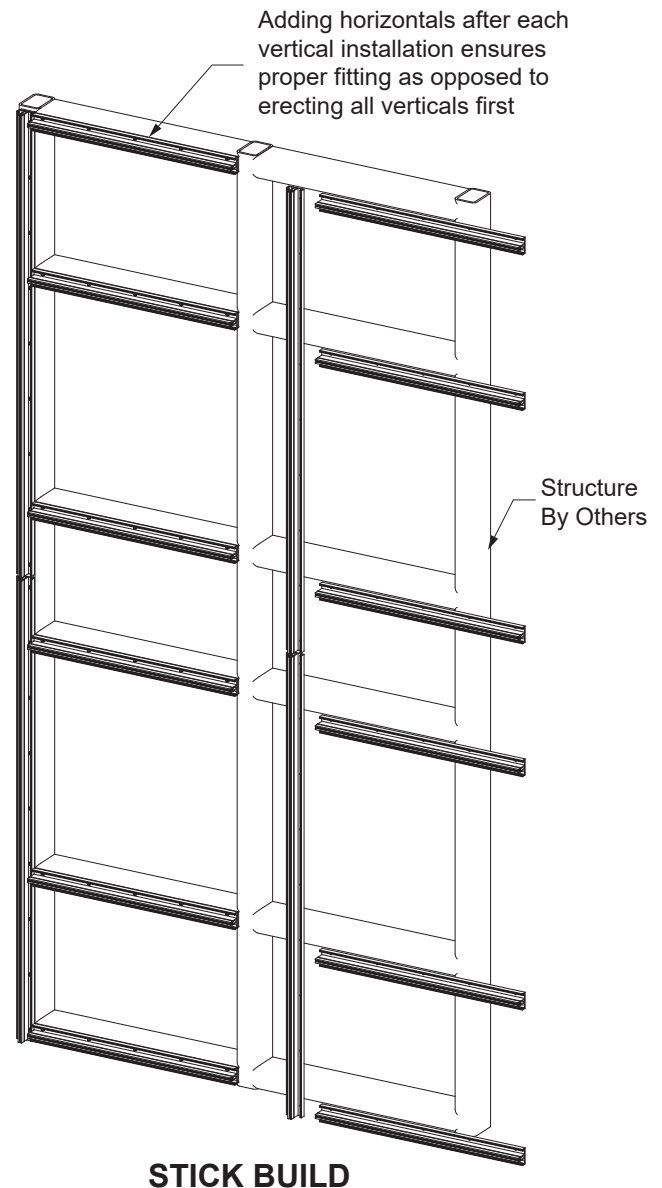

## FRAME FABRICATION

### STEP 1 FABRICATE MULLIONS

-Cut vertical mullions to dimensions as shown on the approved shop drawings.  
Allow for 1/2" perimeter caulk joint around the frame (if adjacent to the building substrate).

-Refer to the approved shop drawings and or P.E. calculations for anchor bolt sizes.  
At each end, drill the anchor holes along the V-grooves at 1-1/2" from each end and spaced according to the P.E. calculations. Stagger the placement of the anchor holes for installation on concrete substrates.

See **Detail 1**.

**Note:** To avoid interference with joint plug installation, anchor holes should not be where the horizontals would intersect.

For Steel, Wood, or  
Aluminum Substrates

For Concrete  
Substrates

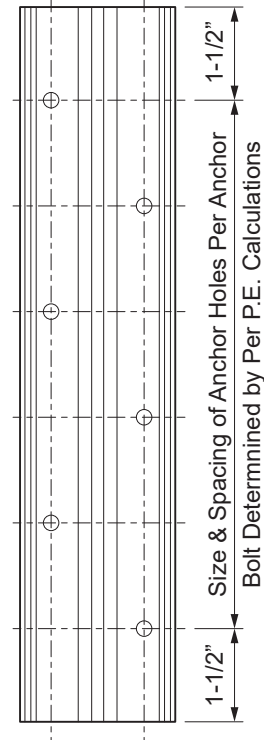
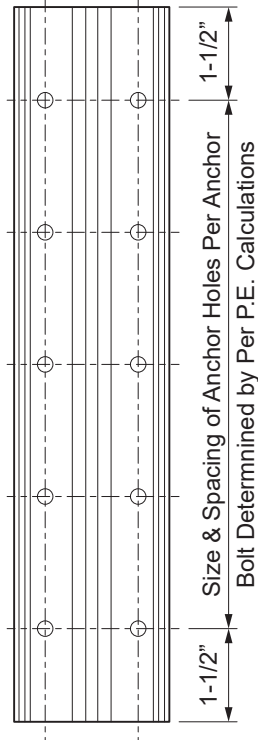
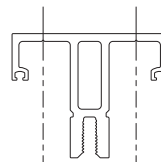
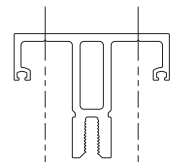

**Detail 1**

FRAME FABRICATION

**STEP 2**  
**FABRICATE HORIZONTALS**

-Cut horizontals according to the Daylight Openings as shown on the approved shop drawings. At each end, drill the anchor holes along the V-grooves at 1-1/2" from each end and spaced according to the P.E. calculations. Stagger the placement of the anchor holes for installation on concrete substrates.

See **Detail 2** below for 2" wide veneer and **Detail 2A** on next page for 2-1/2" wide veneer.

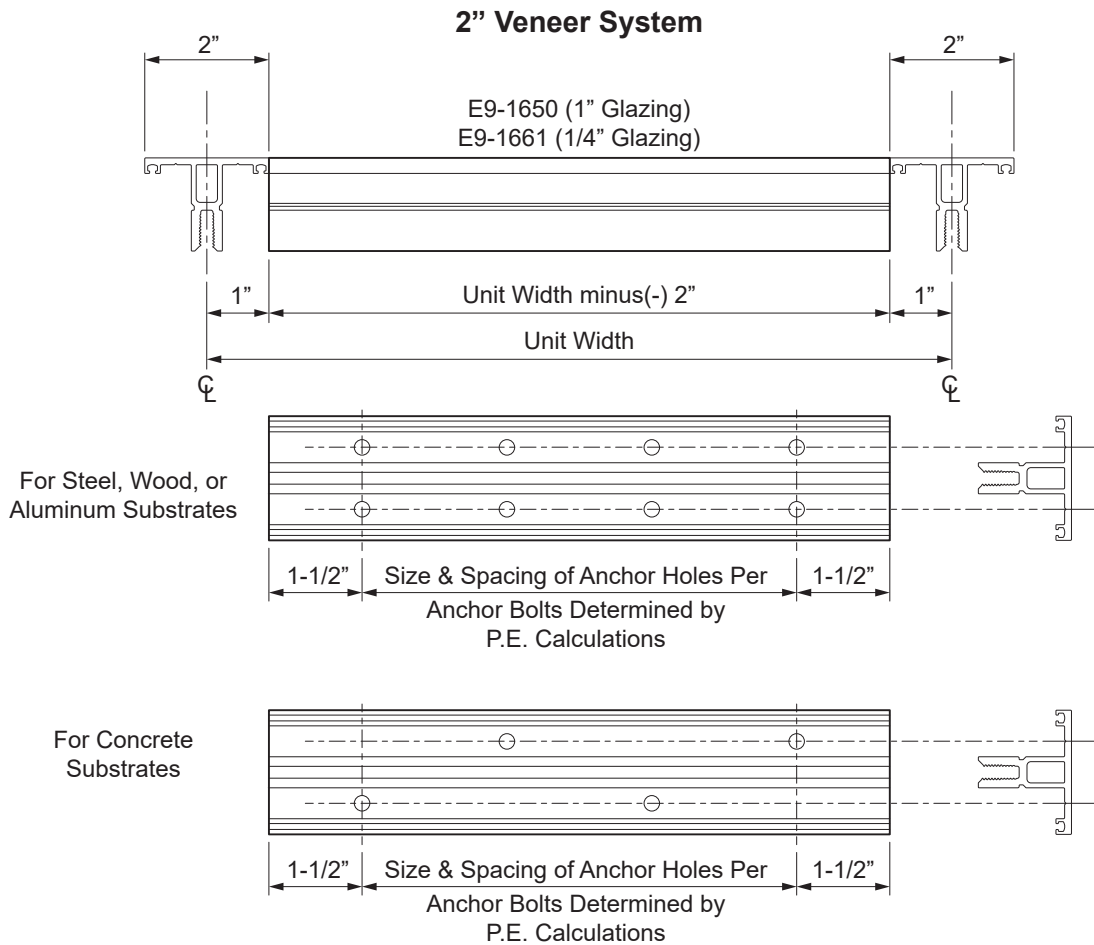

**Detail 2**  
2" Wide Framing

**FRAME FABRICATION**

**STEP 2 (Continued)  
FABRICATE HORIZONTALS**

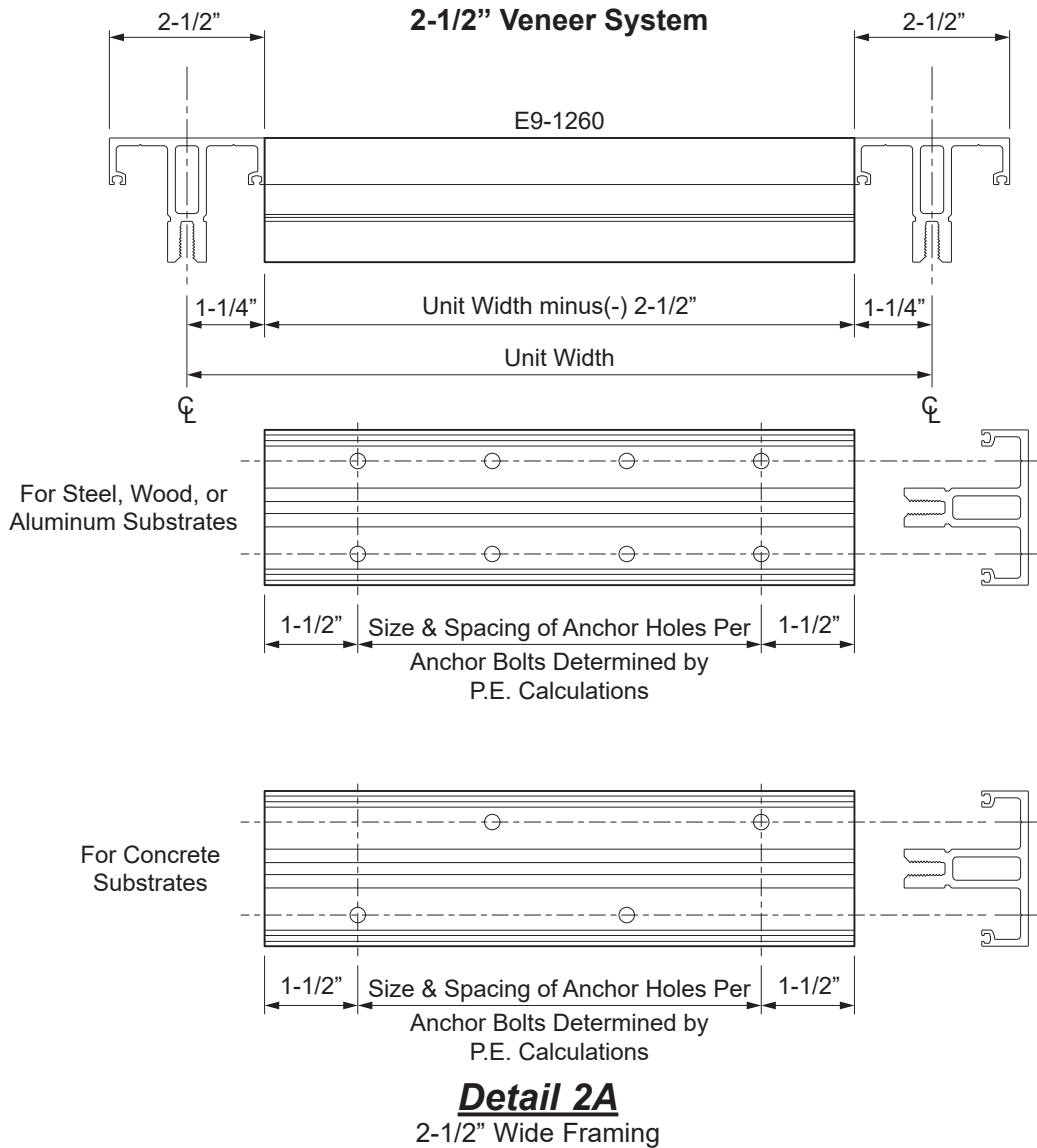

FRAME FABRICATION

STEP 3  
FABRICATE PRESSURE PLATES

Horizontal Pressure Plates:

- Cut horizontal pressure plates to the daylight opening between verticals minus(-) 1/4".
  - Pressure plate stock lengths have 0.281" dia. holes factory drilled every 9".
  - After cutting, drill additional holes if required to ensure that end holes are 1-1/2" from each end.
  - If factory drilled holes are less than 1-1/2" from the ends, they must be sealed and not used.
  - Drill two 0.313" (5/16") diameter weep holes 3" from each end and one at the centerline of the pressure plate. Weep holes are always drilled above the thermal isolator.
- See **Detail 3**.

**Note:** If the space between the weep holes exceeds 3', additional weep holes should be drilled to ensure that there is no more than 3' between the weep holes.

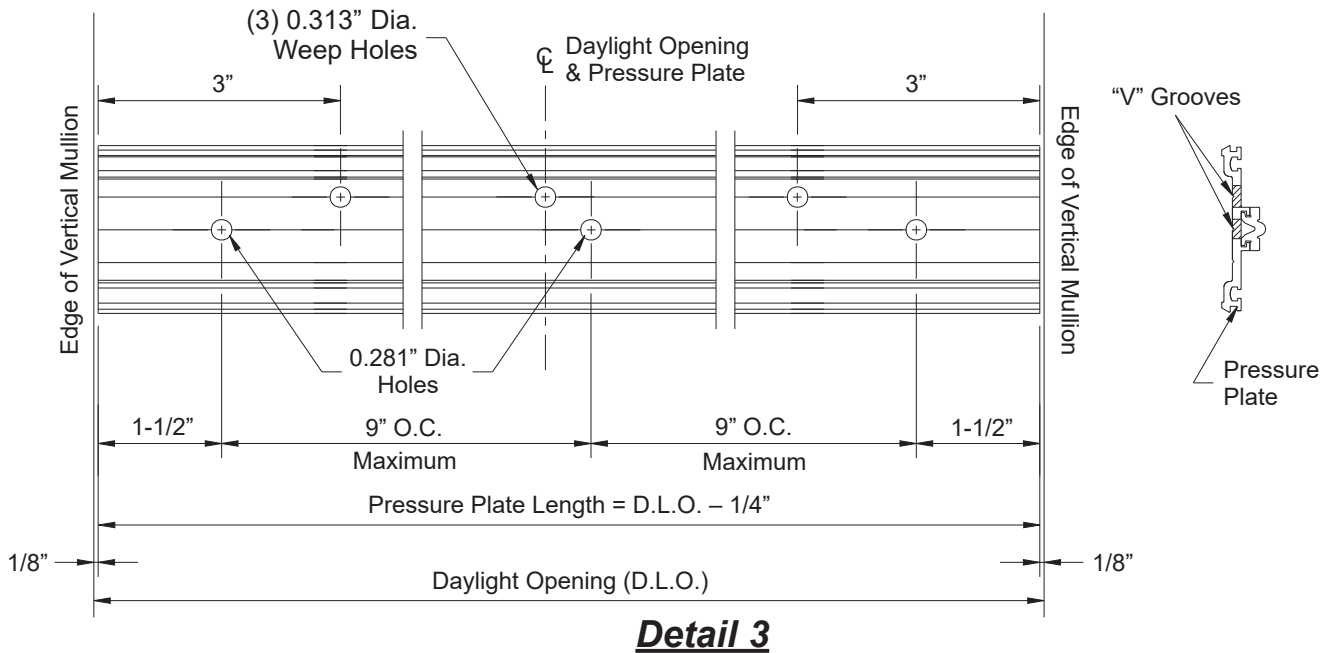

Vertical Pressure Plates:

- Cut vertical and jamb pressure plates to the same length as the vertical mullions.
- Drill additional attachment holes if required to ensure that end holes are 1-1/2" from each end.

**Note:** For expansion and contraction of exterior pressure plates and face covers, refer to the **YCW 750 OG Installation Manual**.

**FRAME FABRICATION**

**STEP 4  
FABRICATE FACE COVERS**

**Horizontal Face Covers:**

- Cut horizontal face covers to the daylight opening between verticals minus(-) 1/16".
  - Drill two 0.313" diameter weep holes at 1/3 points of cover as shown below.
- See **Detail 4**.

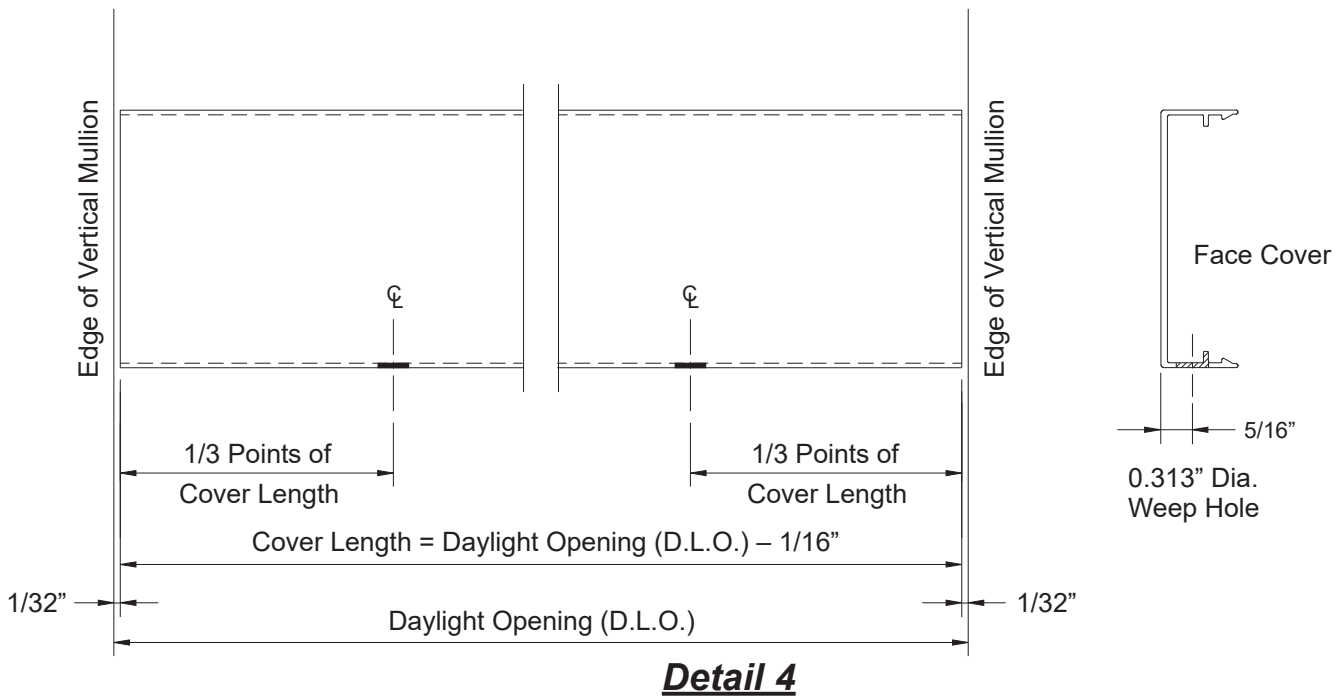

**Vertical Face Covers:**

- Cut vertical face covers to the same length as the mullions.

FRAME INSTALLATION

STEP 5  
INSTALL FRAMING

Install First Vertical Mullion

-Anchor the first vertical mullion onto the substrate using anchor fasteners as specified by the P.E. calculations. The shim space between the mullion and the substrate is to be a maximum of 3/8".

See **Detail 5**.

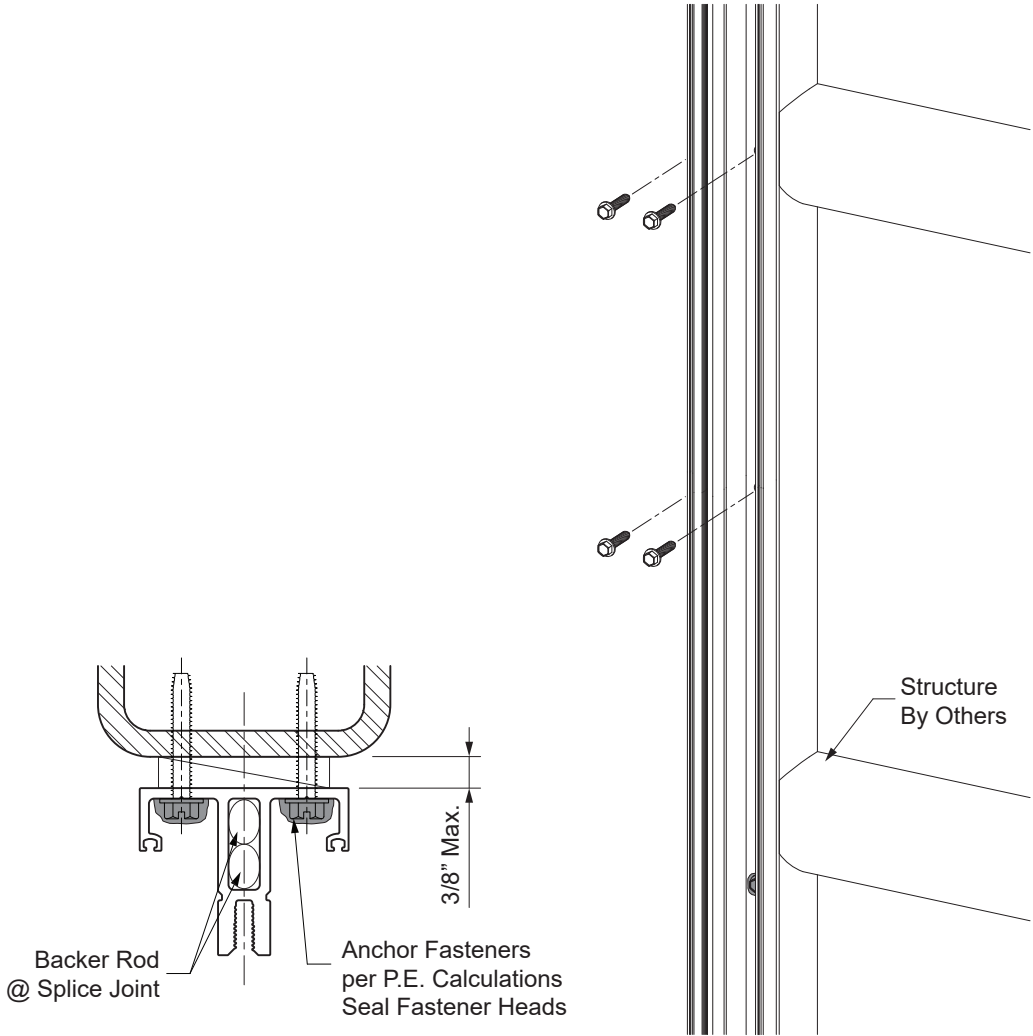

**Detail 5**

**FRAME INSTALLATION**

**STEP 5 (Continued)  
INSTALL FRAMING**

**Install Horizontals**

-Prior to installing each horizontal, apply sealant to the end of the horizontal that is to be placed against the installed mullion as shown in **Detail 6**.

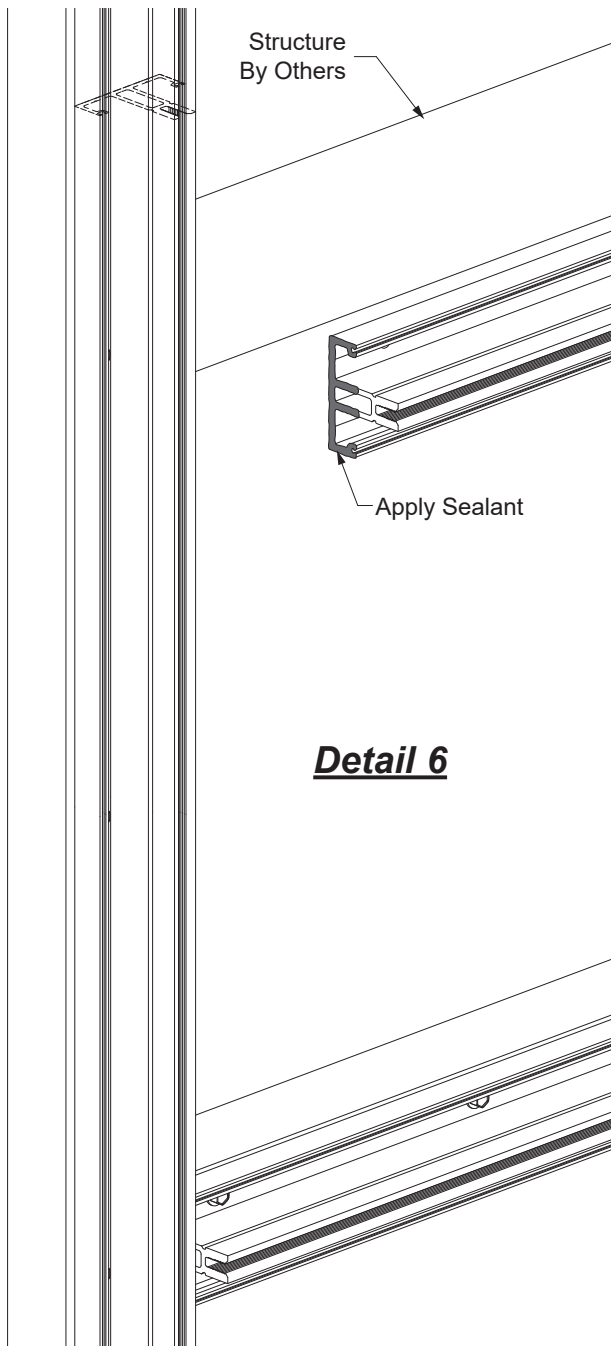

-Anchor the horizontal tight against the mullion using the fasteners as specified by the P.E. calculations.

-Tool sealant to the joint between the horizontal and the vertical mullion.

See **Detail 7**.

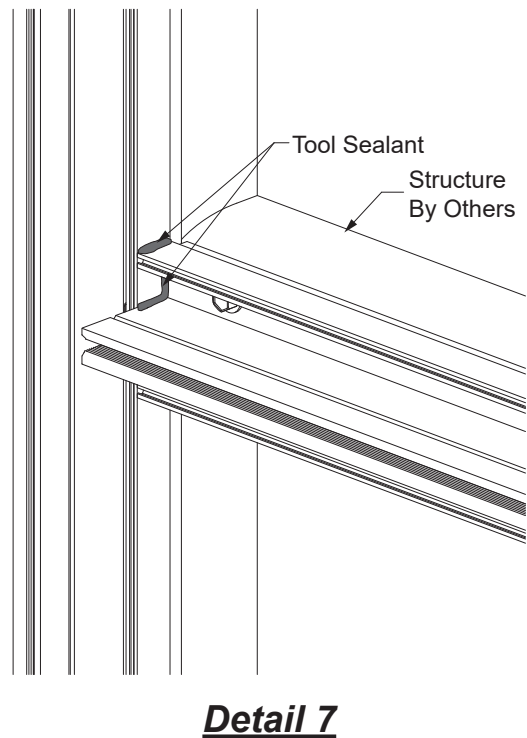



## FRAME INSTALLATION

### STEP 5 (Continued) INSTALL FRAMING

#### Install Next Mullion

- Prior to installing the next mullion, apply sealant to the ends of all the installed horizontals as shown in **Detail 8**.
- Immediately anchor the next mullion onto the substrate and against the installed horizontals.
- Tool sealant to the joint between the horizontals and the mullion as previously shown in **Detail 7**.

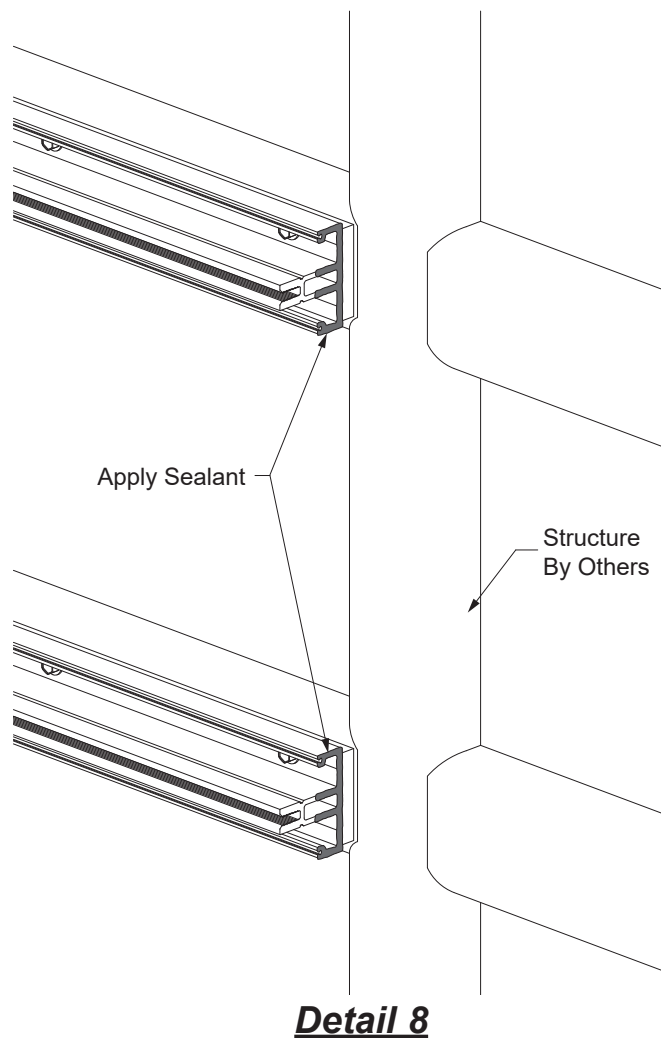

- Continue installing the framing, repeating the process on **Pages 11** through **13** until all the verticals and horizontals are installed.

**FRAME INSTALLATION**

**STEP 6  
APPLY PERIMETER SEALANT**

- Clean the area around the perimeter of the frame with cleaner and method approved by sealant manufacturer.
- Push in backer rod between the perimeter of the frame and the substrate inward about 1/4".
- Apply sealant to the perimeter of the frame.
- Tool the sealant to ensure a water tight joint.

See **Detail 9**.

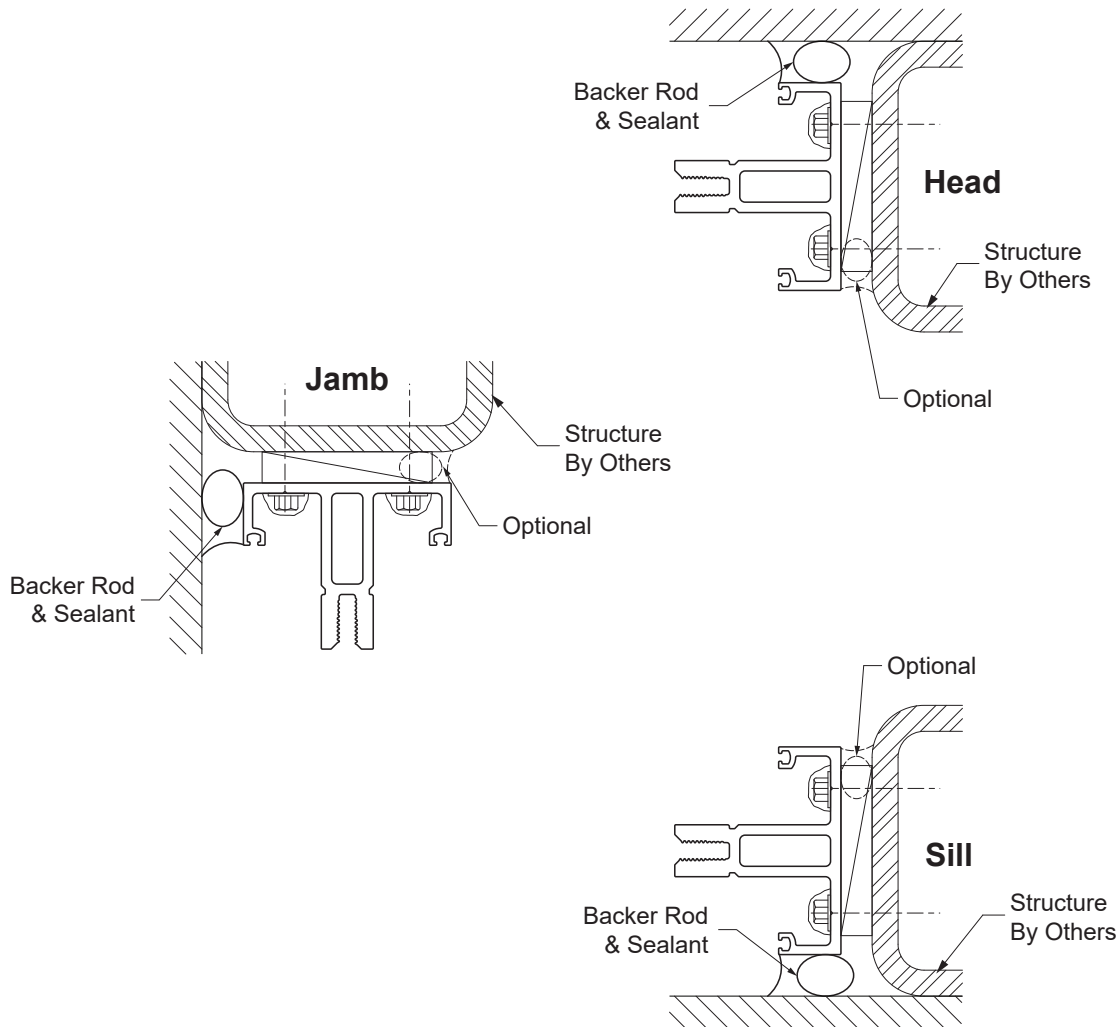

**Detail 9**

## FRAME INSTALLATION

### STEP 7 INSTALL JOINT PLUGS

The tongue of each head, horizontal and sill must be sealed to the tongue of the vertical and jamb mullions at each end with joint plugs:

- E2-0138 for 2" wide system, 1" Glazing
- E2-0285 for 2" wide system, 1/4" Glazing
- E2-0205 for 2-1/2" wide system

- Clean the area around the mullion tongue ends with an approved cleaner.
- Apply and tool sealant to the joint where the horizontal meets the vertical.
- Apply sealant to the three contact sides of the joint plug.
- Install joint plug as shown with the long leg of the joint plug against the vertical tongue.
- Press the joint plug firmly against the face of the mullion.
- Tool the sealant to ensure a watertight seal.

See **Detail 10**.

**Note:** For 2" framing, it will necessary to fill the cavity behind the joint plugs with sealant.  
See **Detail 10A**.

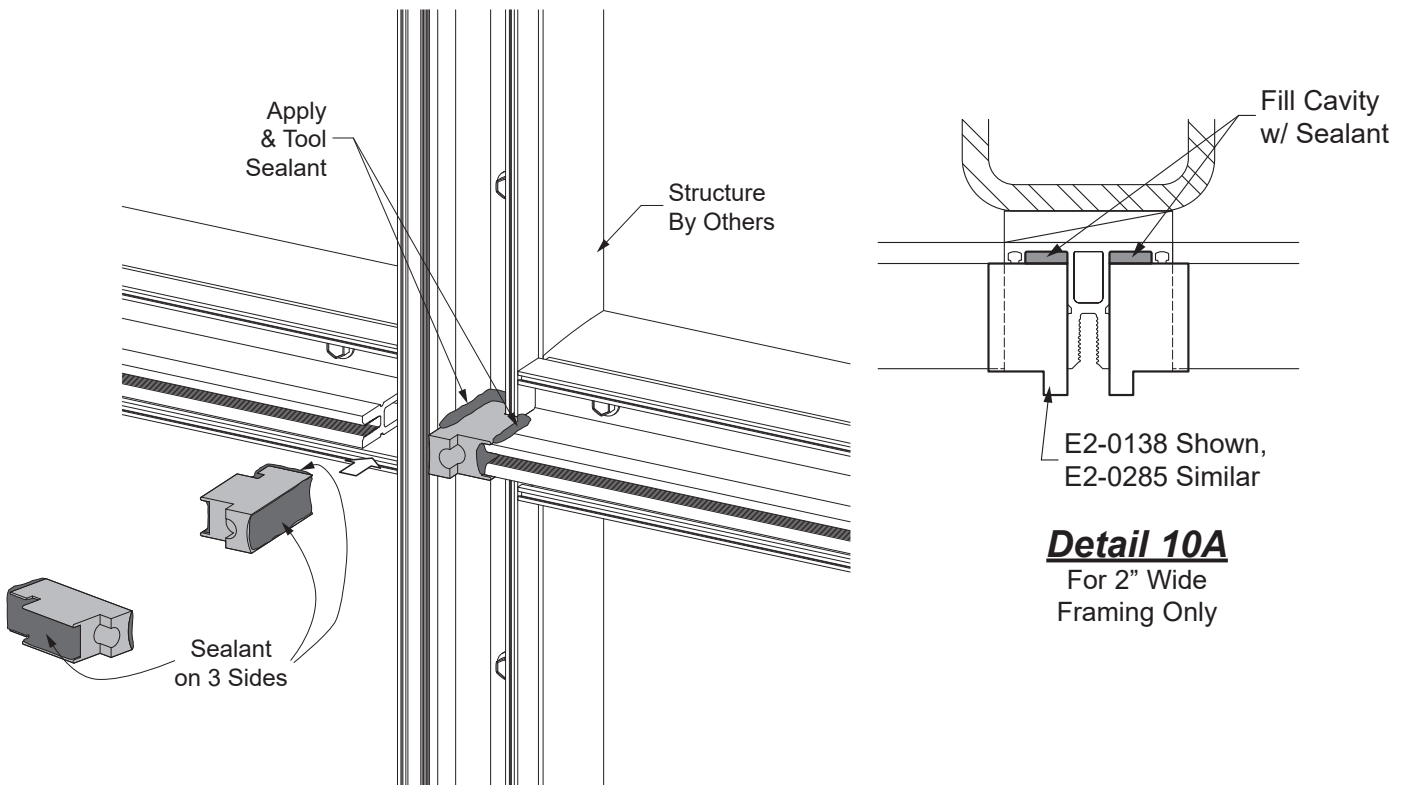

**Detail 10**  
E2-0205 Joint Plug  
Shown, Others Similar

**Detail 10A**  
For 2" Wide  
Framing Only

**GLAZING**

**STEP 8 (OPTIONAL)  
INSTALL GLAZING ADAPTORS**

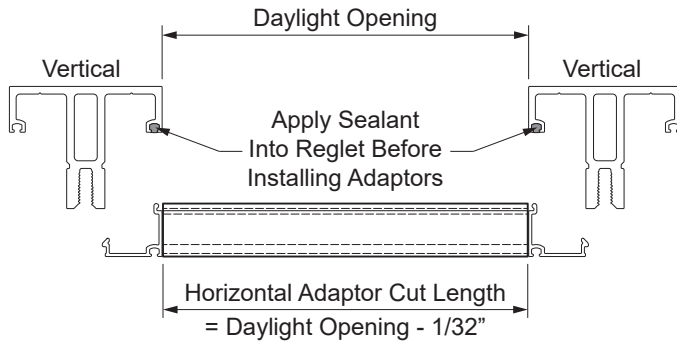

**Detail 11**

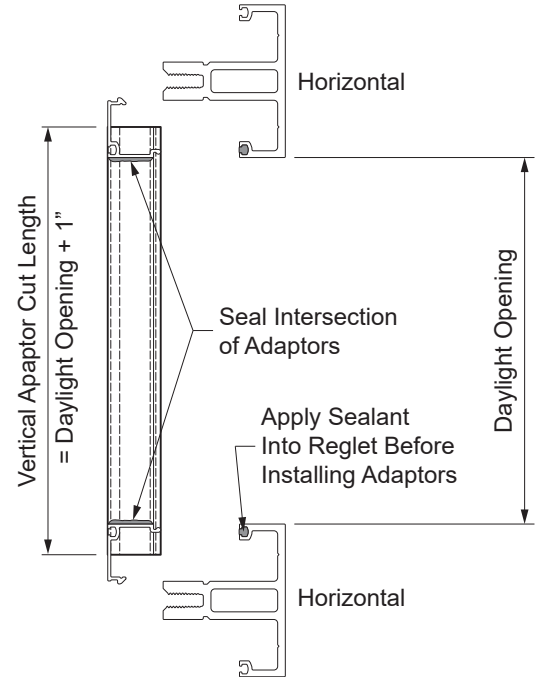

- Cut glazing adaptors to:  
Vertical Cut Length = D.L.O. plus(+) 1".  
Horizontal Cut Length = D.L.O. minus(-) 1-32"

See **Detail 11**.

- Clean the glazing reglets and the glazing adaptors with a cleaner approved by the sealant manufacturer.
- Apply sealant into the glazing reglet of the mullions, the horizontal members, and the ends of the horizontal glazing adaptors.
- Snap in the vertical adaptors into the mullion first, centered on the vertical D.L.O.
- Snap in the horizontal glazing adaptors. Tool sealant at all the adaptor intersections.

See **Detail 12**.

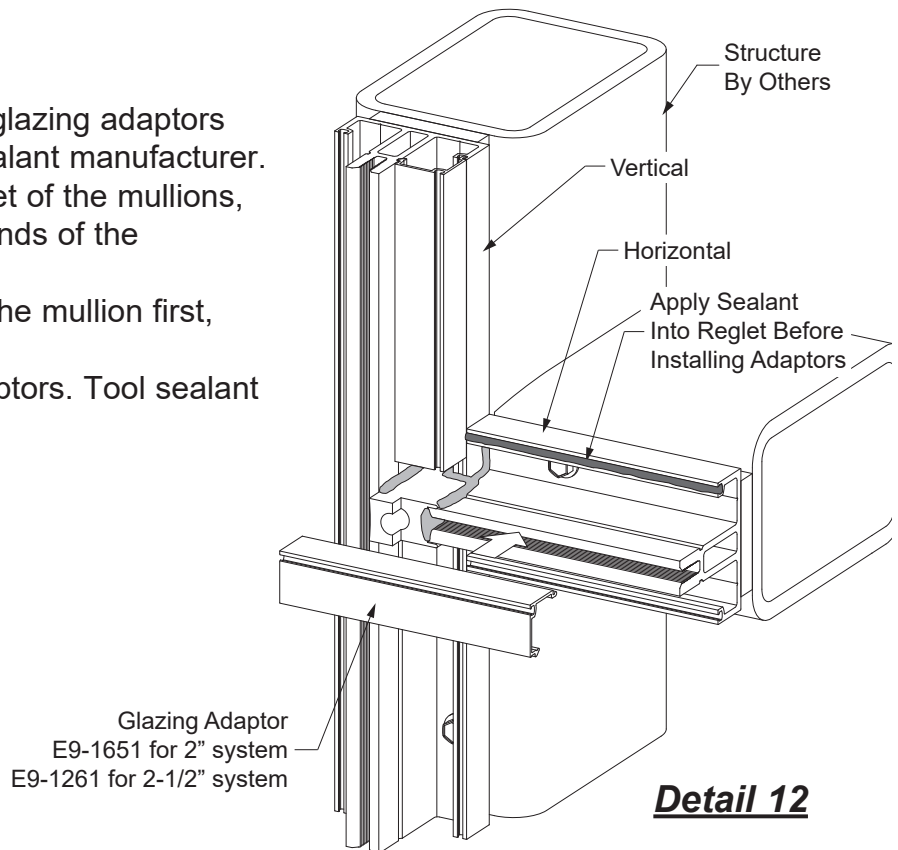

**Detail 12**

## GLAZING

### STEP 9 INSTALL JOINT PLUGS

- Cut interior glazing gaskets to size:
  - Vertical Gasket = Daylight Opening + 1"
  - Horizontal Gasket = Daylight Opening + 1/4" per each foot of opening width
- Install vertical gaskets first, centered along the daylight opening.
- Install horizontal glazing gaskets next.
  - Insert the glazing gasket into the reglet at each end first.
  - Snap the rest of the glazing gasket into the reglet starting at the center and work towards each end.

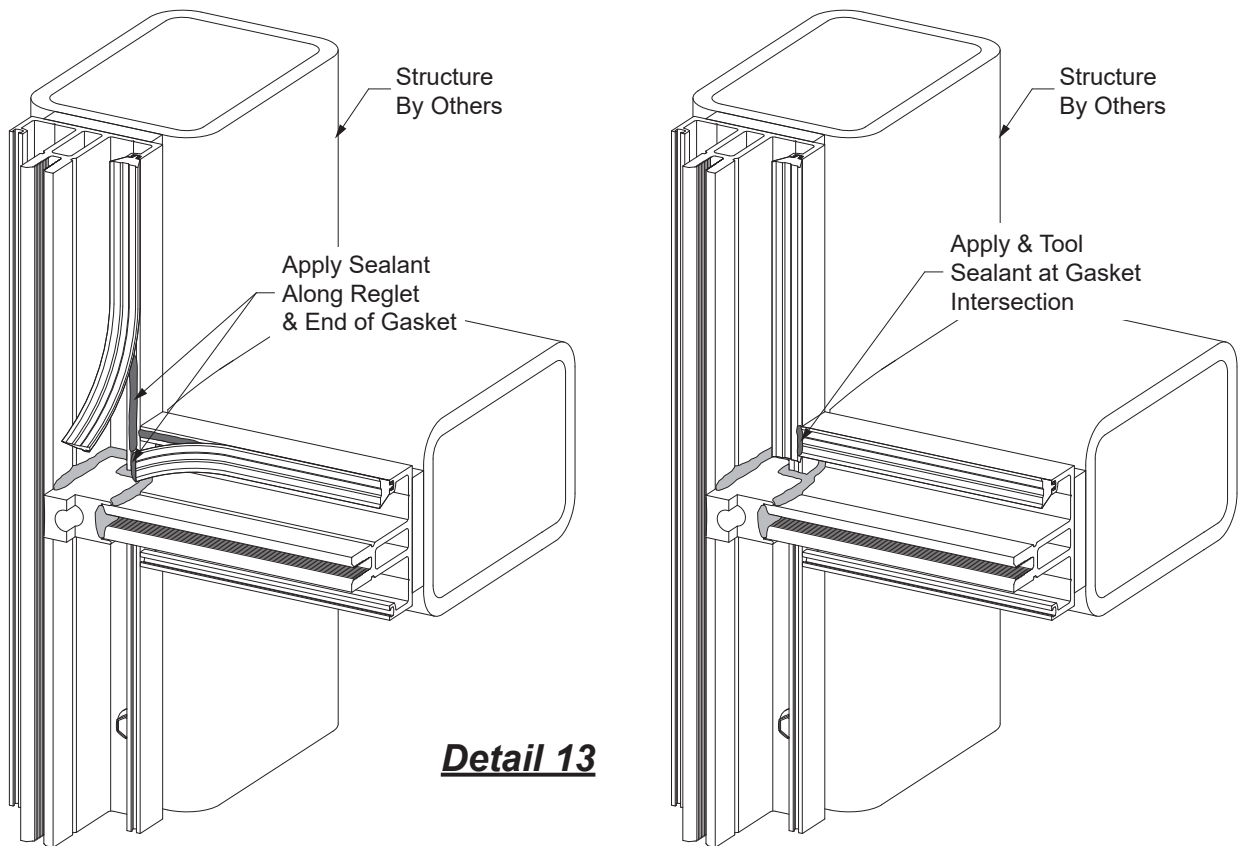

- Pull the last 3" of each gasket away from the reglet.
- With gasket end held out of the way, run a 2-3" bead of sealant into the reglet at the ends.
- Apply sealant at the ends of the horizontal gaskets.
- Reinsert the ends of the gasket pressing them firmly against the face of the mullions.
- Apply and tool sealant at the intersection of the vertical and horizontal gaskets.

See **Detail 13**.

**GLAZING**

**STEP 10  
INSTALL SETTING & SIDE BLOCKS**

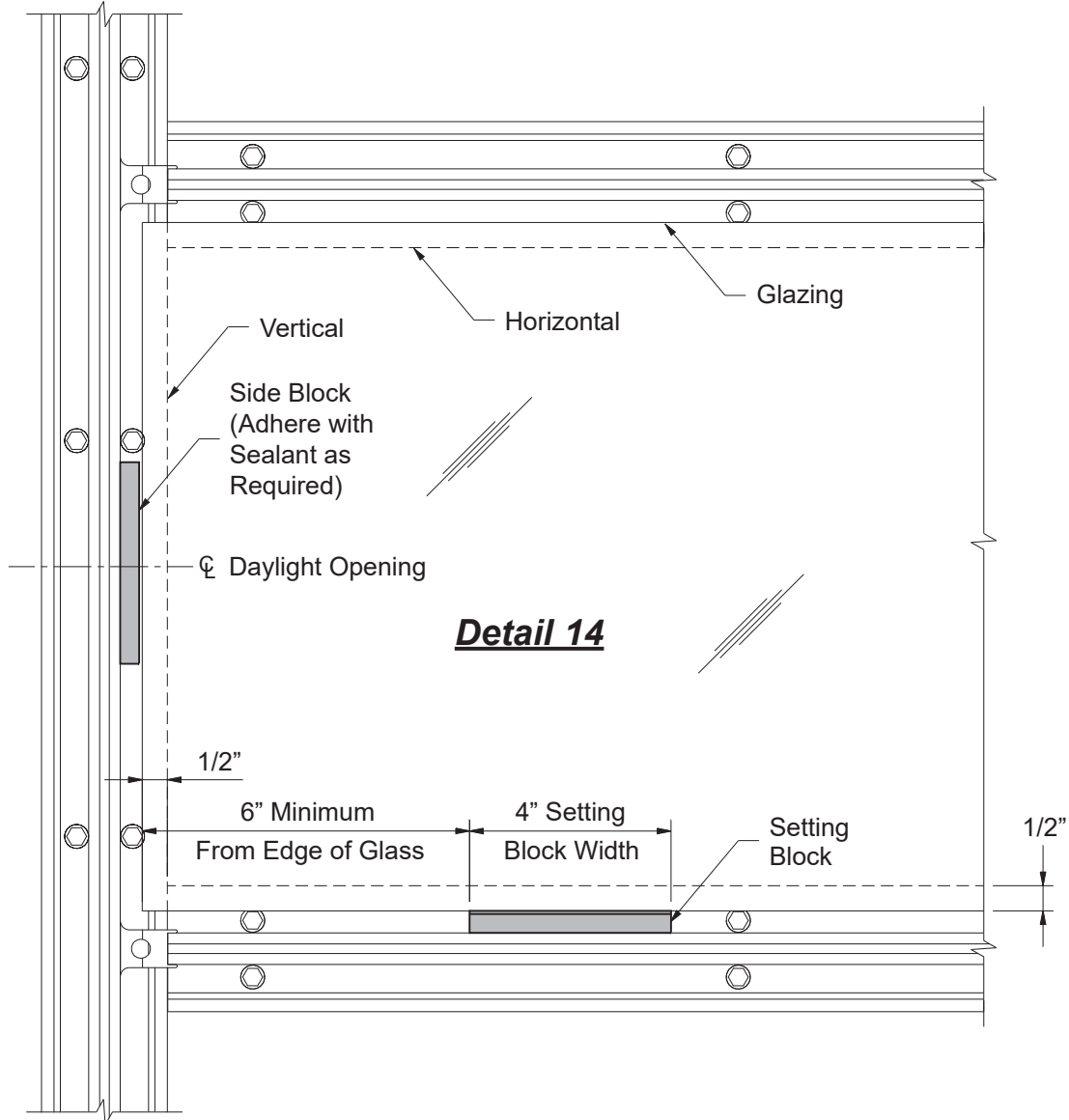

-Install setting blocks at 1/4 points of D.L.O. or minimum of 6" from edge of glass, whichever is greater:

- E2-0104 for 2-1/2" framing
- E2-0134 for 2" framing, 1" glazing
- E2-0623 for 2" framing, 1/4" glazing

Consult YKK AP for setting block requirements on units that exceed 60" x 90" or 40 sq. ft.

-Install side blocks, centered along the daylight opening on both sides of glazing material:

- E2-0105 for 2-1/2" (adhere with sealant)
- E2-0133 for 2" framing, 1" glazing
- E2-0624 for 2" framing, 1/4" glazing

See **Detail 14**.

## GLAZING

### STEP 11 INSTALL EXTERIOR GLAZING GASKETS

- Preload exterior vertical glazing gaskets to the same length as the vertical pressure plates.
- Preload exterior horizontal glazing gaskets to daylight opening plus 1/4" per foot of opening width.
- Install vertical glazing gaskets onto the vertical pressure plates.
- Install horizontal gaskets by pushing each end into the reglet of the pressure plate. Next, press center of gasket into reglet; then push gasket into reglet working from center towards the ends.

**Caution:** Do not stretch the gaskets.

See **Detail 15**.

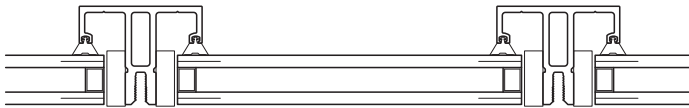

**Detail 15**

### STEP 12 INSTALL GLASS

**Glass and Spandrel Size = Daylight Opening + 1" Horizontally and Vertically.**

- As each lite is installed, attach a temporary retaining clip, E1-1294, in the middle of each horizontal and 4" from glass edge at each end using HD-2516-W3-SS fasteners.
- The temporary retaining clips can be re-used.
- Apply sealant to the face of the joint plugs just prior to installing vertical pressure plates. Do not allow sealant to skim over prior to installing pressure plates.

**Note:** Sealant must form a complete seal between the exterior gasket, pressure plate, thermal isolator, and the joint plug.

See **Detail 16**.

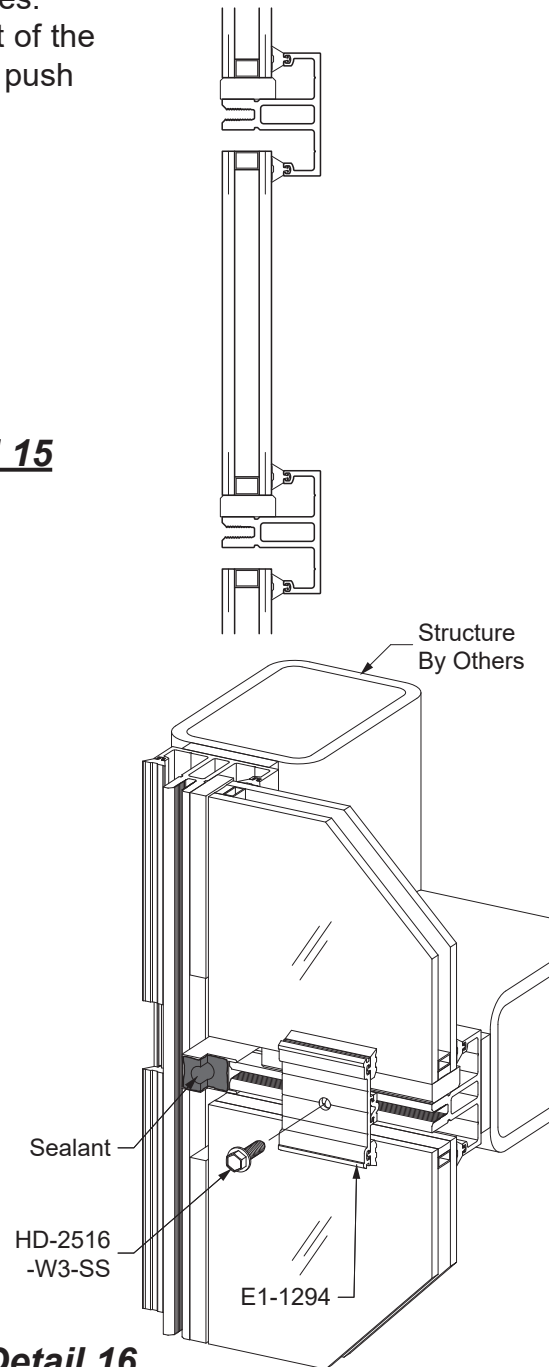

**Detail 16**

## GLAZING

### STEP 13 PRESSURE PLATE LAYOUT AND ASSEMBLY

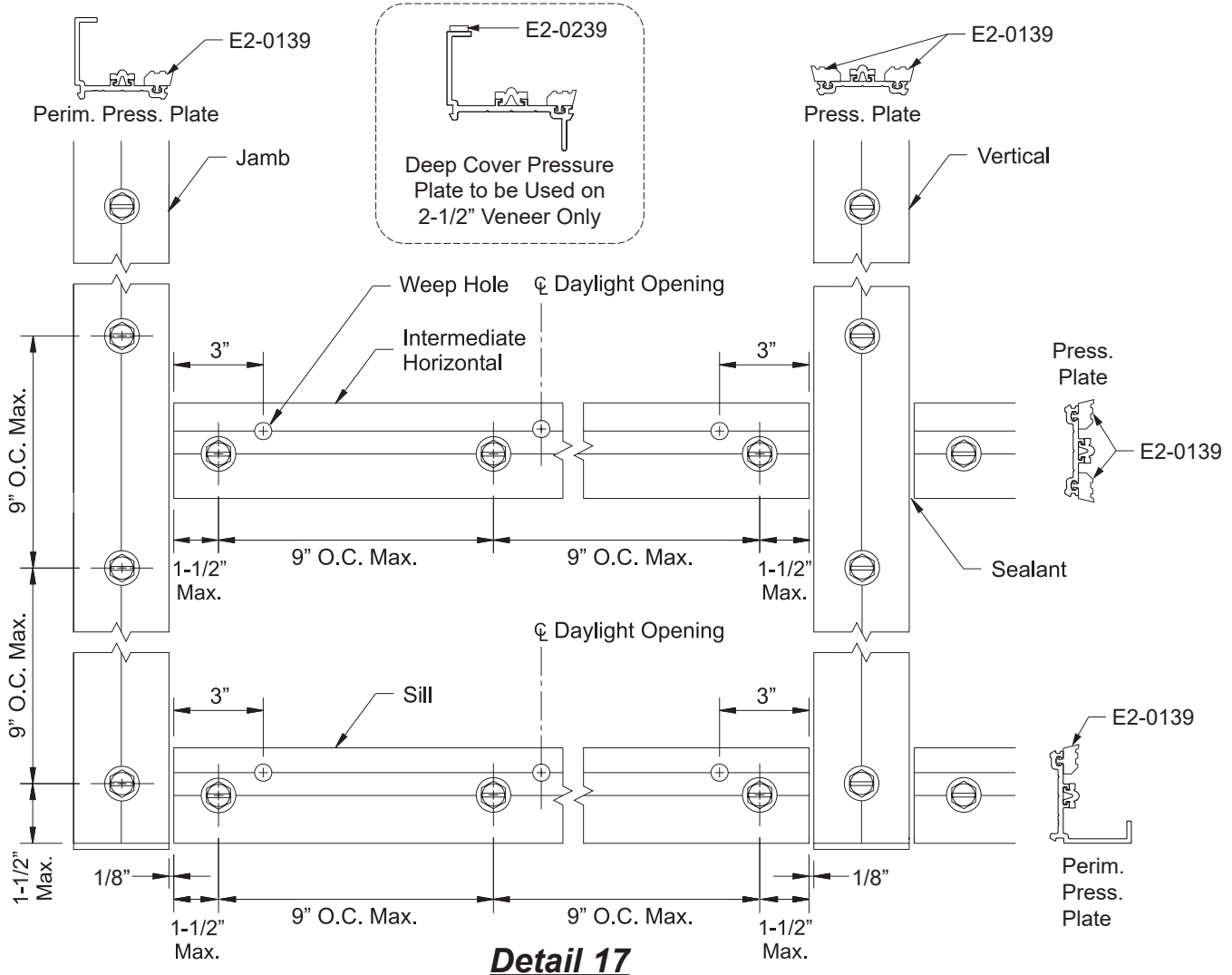

-Pressure plate stock lengths are factory punched with 0.281" diameter holes at 9" o.c. maximum. After cutting, additional holes may be required to have bolts at 1-1/2" of each end. Seal over any pressure plate holes less than 1-1/2" from the ends.

See **Detail 17**.

-For 2-1/2" wide veneer with deep covers, install isolator tape, E2-0239 onto the back leg of the perimeter pressure plates.

-Cut the vertical exterior glazing gasket E2-0139 to length of pressure plate, and the horizontal gasket to the daylight opening. Attach glazing gaskets to the pressure plate.



## GLAZING

### STEP 13 (Continued)

#### PRESSURE PLATE LAYOUT AND ASSEMBLY

- Install vertical pressure plates using HD-2516-W3-SS bolts. Initially torque bolts to 30 inch-pounds with a speed wrench or torque limiting screw gun. Work from the bottom up.
- Torque all vertical pressure plate bolts to 50 inch-pounds.
- Snap on exterior vertical covers using a mallet and a clean scrap piece of lumber. See **Detail 18** on **Page 22**. Start at one end and work block and mallet down the vertical.
- Center and install horizontal pressure plates in opening, leaving a 1/8" gap at the ends.
- Starting at the center of each pressure plate, initially torque each fastener to 30 inch-pounds. Then, tighten all of the fasteners to 50 inch-pounds.

**GLAZING**

**STEP 14  
INSTALL EXTERIOR FACE COVERS**

- Seal the gap at the end of the horizontal pressure plate to the vertical face cover.
- Snap on horizontal cover, working the mallet across the horizontal.

See **Detail 19**.

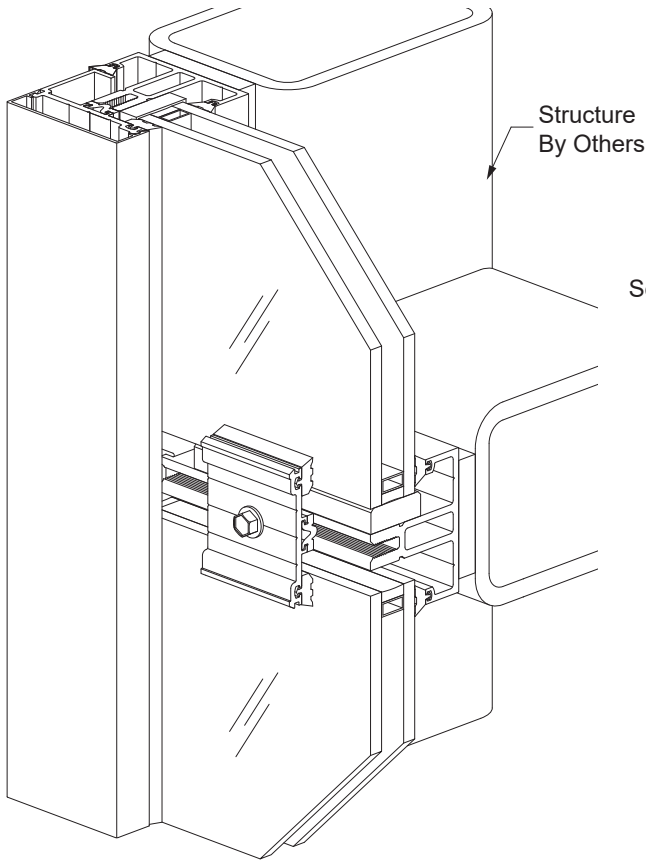

**Detail 18**

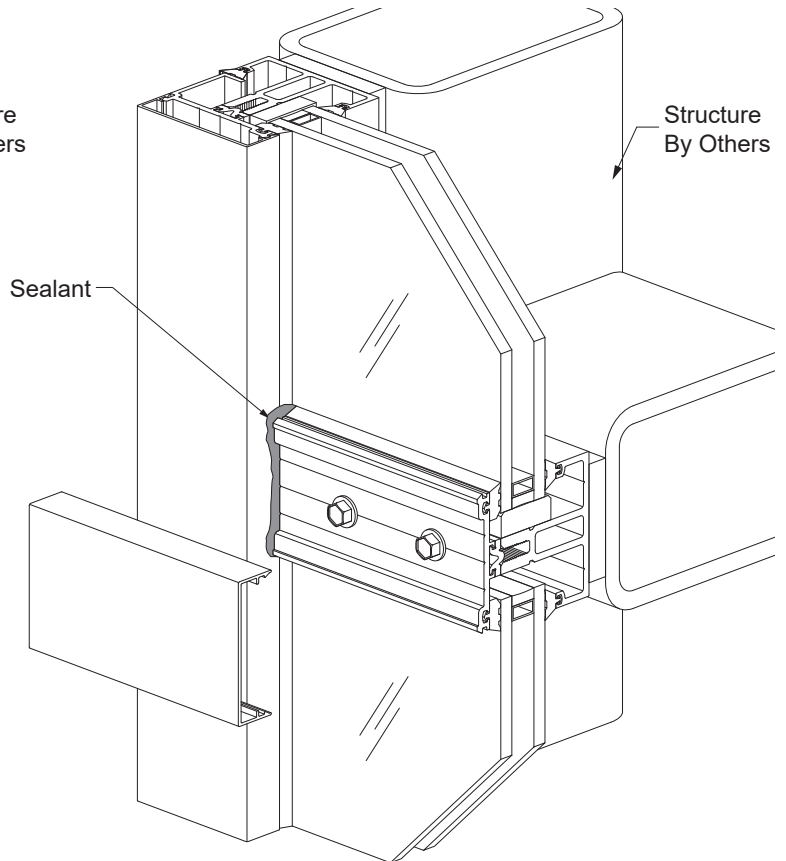

**Detail 19**

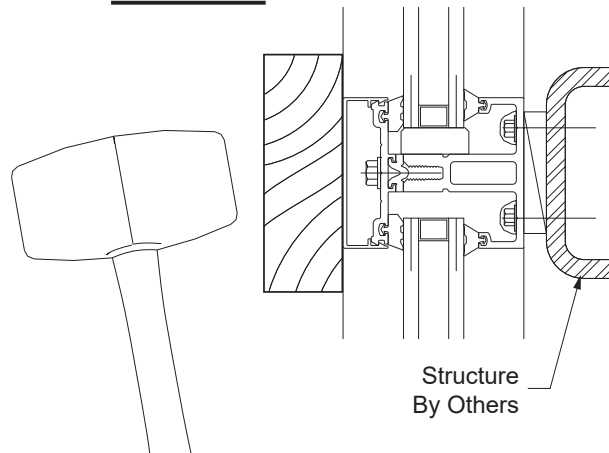

## GLAZING

### STEP 14A

### INSTALL OPTIONAL DEEP FACE COVERS (2-1/2" WIDE SYSTEM ONLY)

Installation of a deep vertical cover is similar to that of the standard face cover, except a fastener is required to keep the cover from possibly sliding down over time. Typically, the face cover is fastened with one PC-0808-SS screw at a horizontal to be concealed by the horizontal face cover, unless otherwise specified on the approved shop drawings.

-For concealed fastener locations, drill a 0.189" diameter hole into the side of the face cover, 7/16" from the snap interface of the cover. Snap on the deep cover at its intended location. Using the clear hole as a pilot hole, drill a 0.141" diameter tap hole into the leg on the deep pressure plate. Secure the face cover in place with a PC-0808-SS.

**Note:** FC-0808-SS can be used in lieu of a PC-0808-SS.

-If the face cover requires it to be fastened at an exposed location, drill a 0.189" diameter countersunk hole into the side of the cover. Snap on the deep cover at its intended location. Using the clear hole as a pilot hole, drill a 0.141" diameter tap hole into the leg on the deep pressure plate. Secure the face cover in place with an FC-0808-SS screw.

See **Detail 20**.

-Continue to install the horizontal pressure plate and face cover as specified on **Pages 20 thru 22**.

Installation of horizontal deep face covers is similar except the screw is always on the top of the face cover with its head set in sealant.

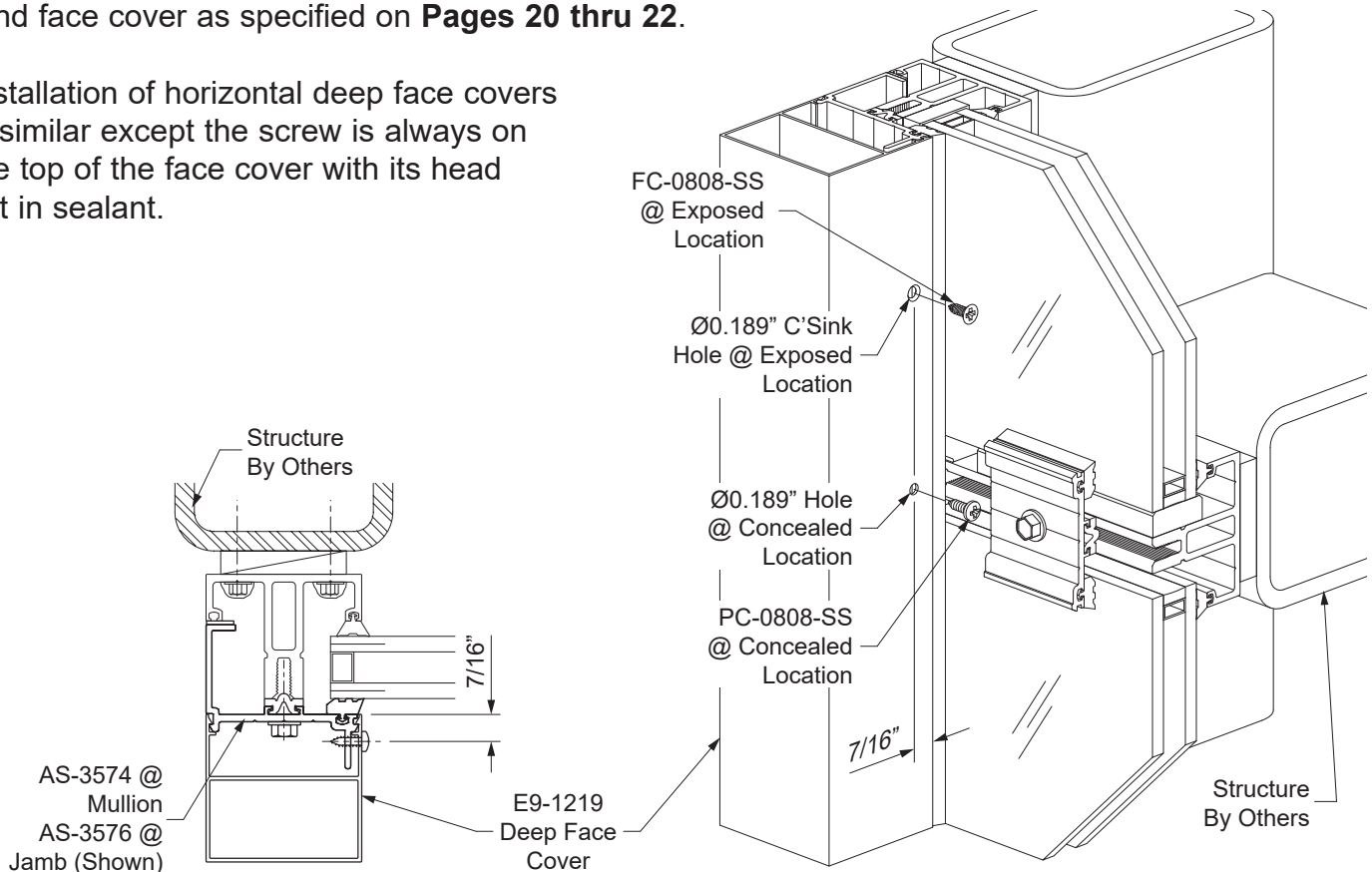

**Detail 20**



101 Marietta Street NW  
Suite 2100  
Atlanta, Georgia 30303  
[www.ykkap.com](http://www.ykkap.com)