

YVS 400 TU Window System

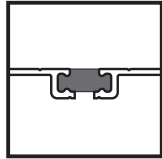

**ThermaBond Plus®
Poured & Debridged
Technology**

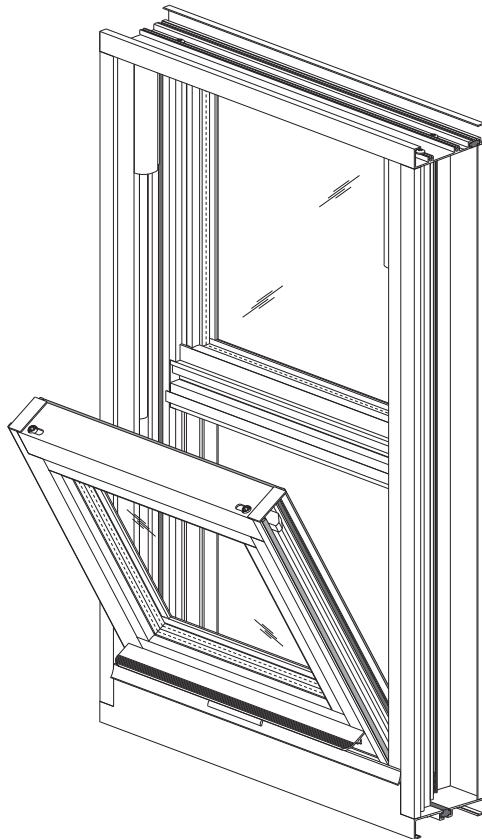

SINGLE HUNG

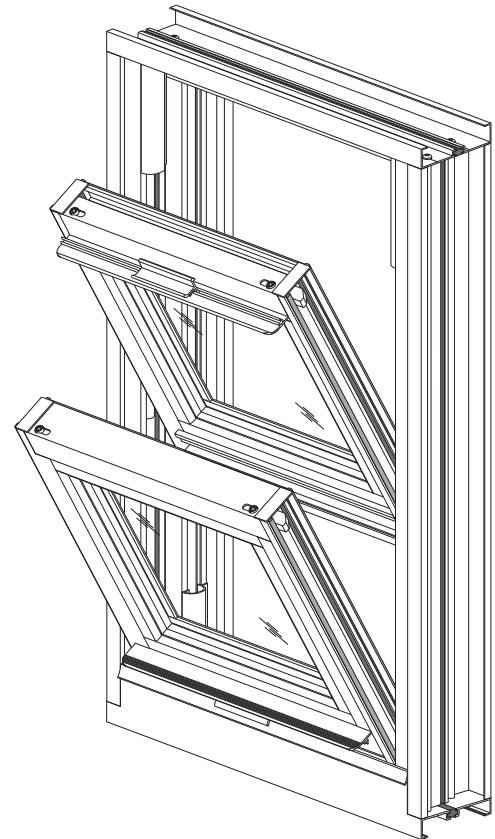

DOUBLE HUNG

YVS 400 TU SYSTEM DESCRIPTION

- 4" Overall Depth
- ThermaBond Plus™ Poured & Debridged Thermal Break
- Variations: Single Hung, Double Hung & Fixed Windows
- 1/8" & 1 1/16" Glazing
- Optional Screens

YVS 400 TU PERFORMANCE FEATURES

- AAMA/NWWDA 101/I.S.2-97
- Factory Mitered & Sealed
- H-AW50 Rating (Single/Double Hung)

Installation Manual

TABLE OF CONTENTS

Installation Notes Page ii & iii

INSTALLATION

Determine Window Reference Point Page 1
Determine Type of Anchors To Be Used Pages 1 & 2
Installation Options and Procedures Pages 3 & 4
Installation of Stacking Mullions Page 5

CLEANING

Cleaning Exterior of Window Page 6

RE-GLAZING

Re-Glazing Hung Windows Pages 7 & 8
Calculating Glass Sizes Page 9

BALANCE ADJUSTMENT / REPLACEMENT

Determine Balance Type Page 10
Balance Adjustment Page 11
Balance Replacement Page 12

INSTALLATION NOTES

1. Do not drop, roll or drag boxes of aluminum framing. Move and stack boxes with proper support to prevent distortion. If fork lifts are used, be especially careful about striking the boxes when lifting or moving.
2. Store in a dry, out of the way area. If rain exposure, condensation or any water contact is likely, then all packaging material should be removed. Wet packaging materials will discolor and may stain aluminum finishes and paints.
3. All materials should be checked for quantity and quality upon receipt, YKK AP must be notified immediately of any discrepancies in shipment.
4. Check to make sure that you have the required shims, sealants, supplies, and tools necessary for the installation (not supplied by YKK AP).
5. Carefully check the openings and surrounding conditions that will receive your material. Remember, if the construction is not per the construction documents, it is your responsibility to notify the general contractor in writing. Any discrepancies must be brought to the general contractor's attention before you proceed with the installation.
6. Collect your shop drawings, materials, packing list, and this installation manual. Carefully review parts location, the sequence of installation, when you glaze it, and how you seal it. Installation instructions are of a general nature and may not cover every condition you will encounter. The shop drawings and/or installation manuals were prepared specifically for the product.
7. Any material substitutions must be of equal or greater quality.
8. Make certain that material samples have been sent for compatibility testing for all manufacturer's sealants involved. Make certain that sealants and backer rod have been installed in strict accordance with the manufacturer's recommendations and specifications.
9. Remember to isolate, in a approved manner, all aluminum from uncured masonry or other incompatible materials.
10. System-to-structure fasteners are not supplied by YKK AP. Fasteners called out on shop drawings are to indicate minimum sizes for design loading.
11. If any questions arise concerning YKK AP products or their installation, contact YKK AP for clarification before proceeding.

INSTALLATION NOTES

12. YKK AP window installation is typically completed before drywall, flooring and other products which may still be in process. Take the extra time to wrap and protect the work produced.
13. YKK AP Model YVS 400 TU windows are pre-finished, prefabricated, preassembled, and preglazed products, and must be protected against damage.
14. Concrete, mortar, plaster, muriatic acid and other alkaline and acid based construction and cleaning materials may be very harmful to window finishes and should be removed with water and mild soap immediately or permanent damage or staining of the finishes will occur. A spot test is recommended before any cleaning agent is used, and abrasive type cleaners must never be used.
15. Windows are never to be used as ladders, step stools, scaffolds, scaffold supports, or as pass through openings for materials.
16. All work must start from, and be referenced to benchmarks, offset lines and/or column centerlines established by the architectural drawings and the general contractor.
17. All windows must be installed plumb, square, level and true, and in accordance with approved shop drawings and these installation instructions.
18. Install all windows in accordance with their mark and type per approved shop drawings.
19. The glass has been specified by shop drawings and YKK AP is not responsible for conformance with local building codes other than to provide the approved glass. It is the installers' responsibility to ensure final compliance of the glazing with all applicable codes.
20. Check our website, www.ykkap.com, for the latest installation manual update prior to commencing work.

INSTALLATION

STEP 1 DETERMINE WINDOW REFERENCE POINT

Establish the window reference lines or the exterior/interior plane of the windows to be installed using either bench marks, offset lines, or column centerlines provided by the general contractor and referenced on the shop drawings. Use the established reference points to determine the installation points for each window opening at the head, jambs, and sill.

STEP 2 DETERMINE THE TYPE OF WINDOW ANCHORS TO BE USED

The type of window anchoring used will depend upon the job conditions and the installer's preference. No. 10 fasteners are to be the minimum size used; consult the shop drawings and engineering calculations as the project conditions may require larger fasteners.

Location of fasteners:

- A maximum of 3" from the corner of all box trim and receptors.
- At 15" on center for balance of fasteners.

See **DETAILS 1, 2, & 3.**

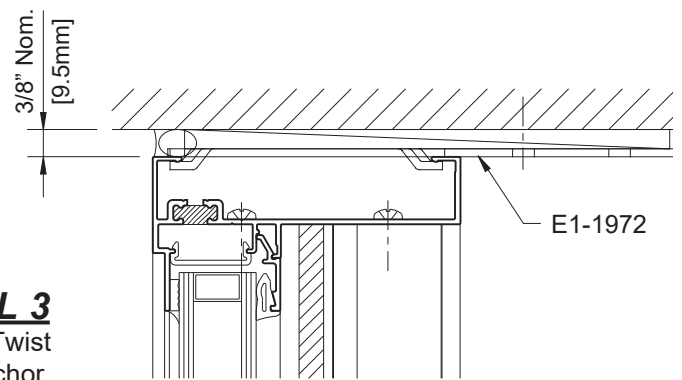
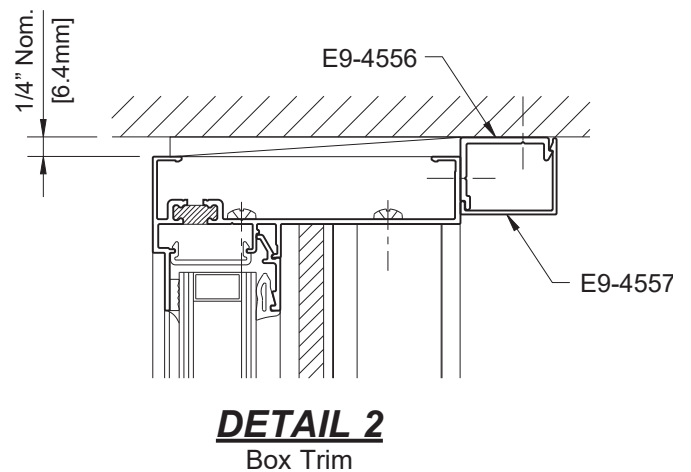
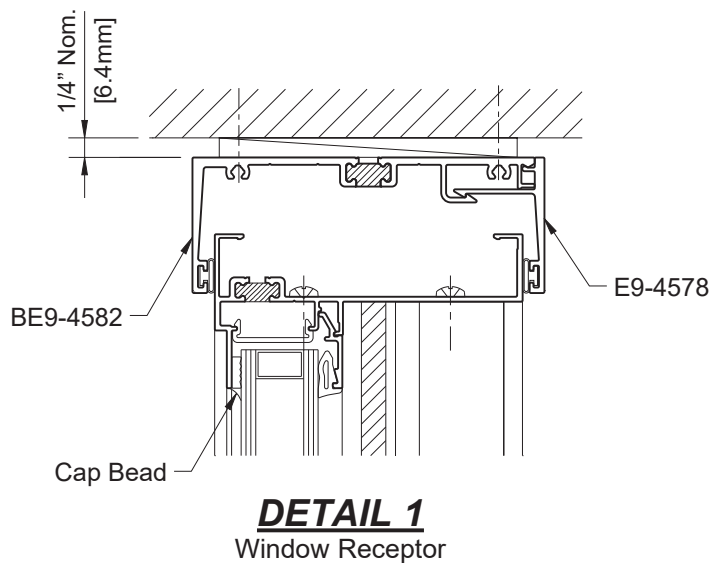

Refer to **Window Accessories Installation** manual for additional information and details.

INSTALLATION

STEP 2 (Continued)

DETERMINE THE TYPE OF WINDOW ANCHORS TO BE USED

Refer to the specific fastener manufacturer's recommendations for proper edge distance and spacing for masonry applications.

CAUTION: Do not fasten ceiling support angles, blind pockets, drapery tracks, convactor covers or stools to the windows or the receptors. The window system is not designed to support the additional load and must be free to expand and contract under normal thermal cycling conditions.

STEP 3

VENTILATOR INSTALLATION AND ADJUSTMENT

All sliding sashes and components must be checked for proper alignment, margins, and operation.

-If necessary adjust the balances as shown in **STEP 9**.

-All hardware must be cleaned and lubricated as necessary to provide smooth operation.

INSTALLATION

STEP 4 INSTALLATION OPTIONS AND PROCEDURES

OPTION 1: Anchor with standard box trim:

1. Install the frame plumb, square, level and true.
 - Refer to **Step 2** or structural calculations for fastener size and location.
 - Shim as required along the frame.
2. Install backer rod and seal with a quality perimeter sealant.

See **DETAILS 4** through **6**.

Note: When installing YVS 400 TU windows with 3/8" caulk joint, box trim members E9-4556 & E9-4557 must be oriented as shown in **DETAIL 7**.

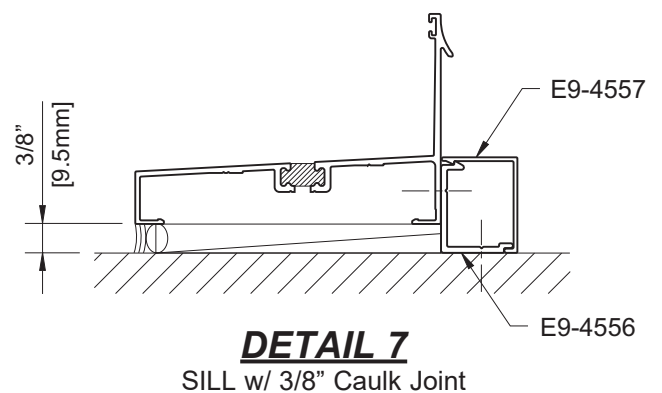
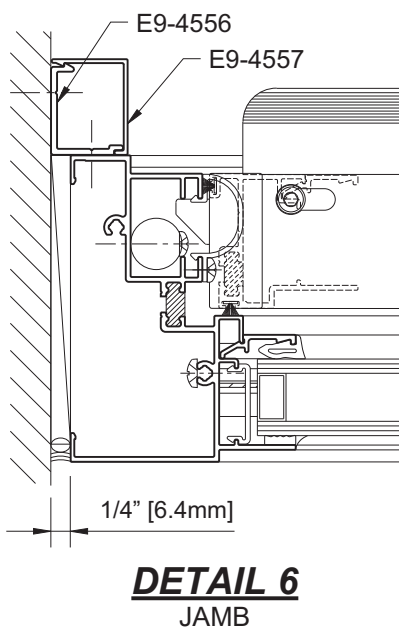
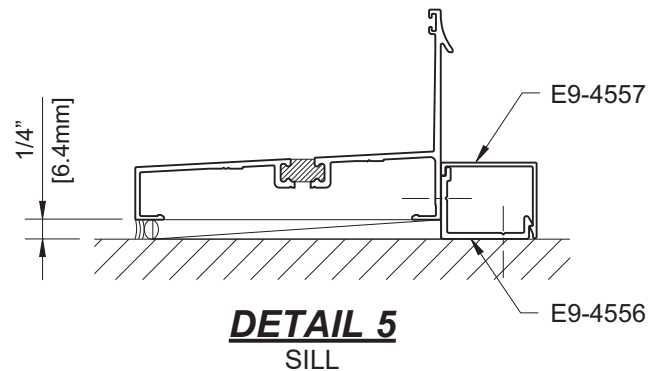
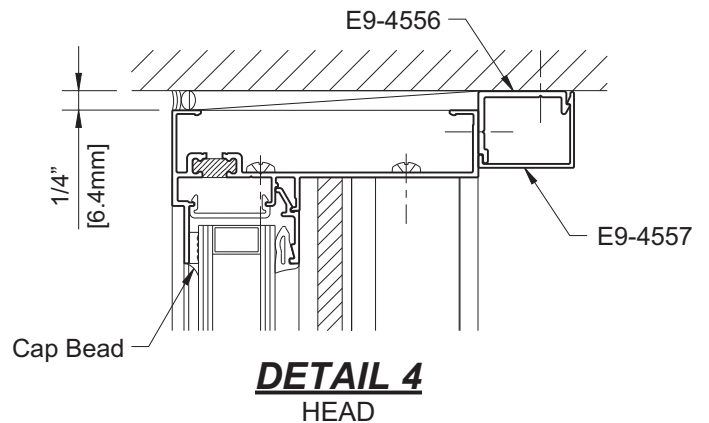

INSTALLATION

STEP 4 (Continued) INSTALLATION OPTIONS AND PROCEDURES

OPTION 2: Install window receptor system at the head only or at the head & jambs:

1. Refer to **Step 2** or structural calculations to determine the size and location of fasteners (minimum #10 fasteners).
2. Shim and secure the exterior leg of receptor(s) using the required fasteners.
3. When receptors are used at both the head and the jamb, the head receptor will run through and sill starter, BE9-4585, should be used as shown.
4. Seal the intersection of receptors and all fasteners in sill starter.
5. Install the window frame into the opening.
6. Shim the sill and jambs of the window to ensure that they are installed plumb, square, level and true.
7. Snap in interior receptor leg(s).
8. Install backer rod and perimeter sealant as shown. Tool the sealant to ensure a water tight joint.

See **DETAILS 8** through **10**.

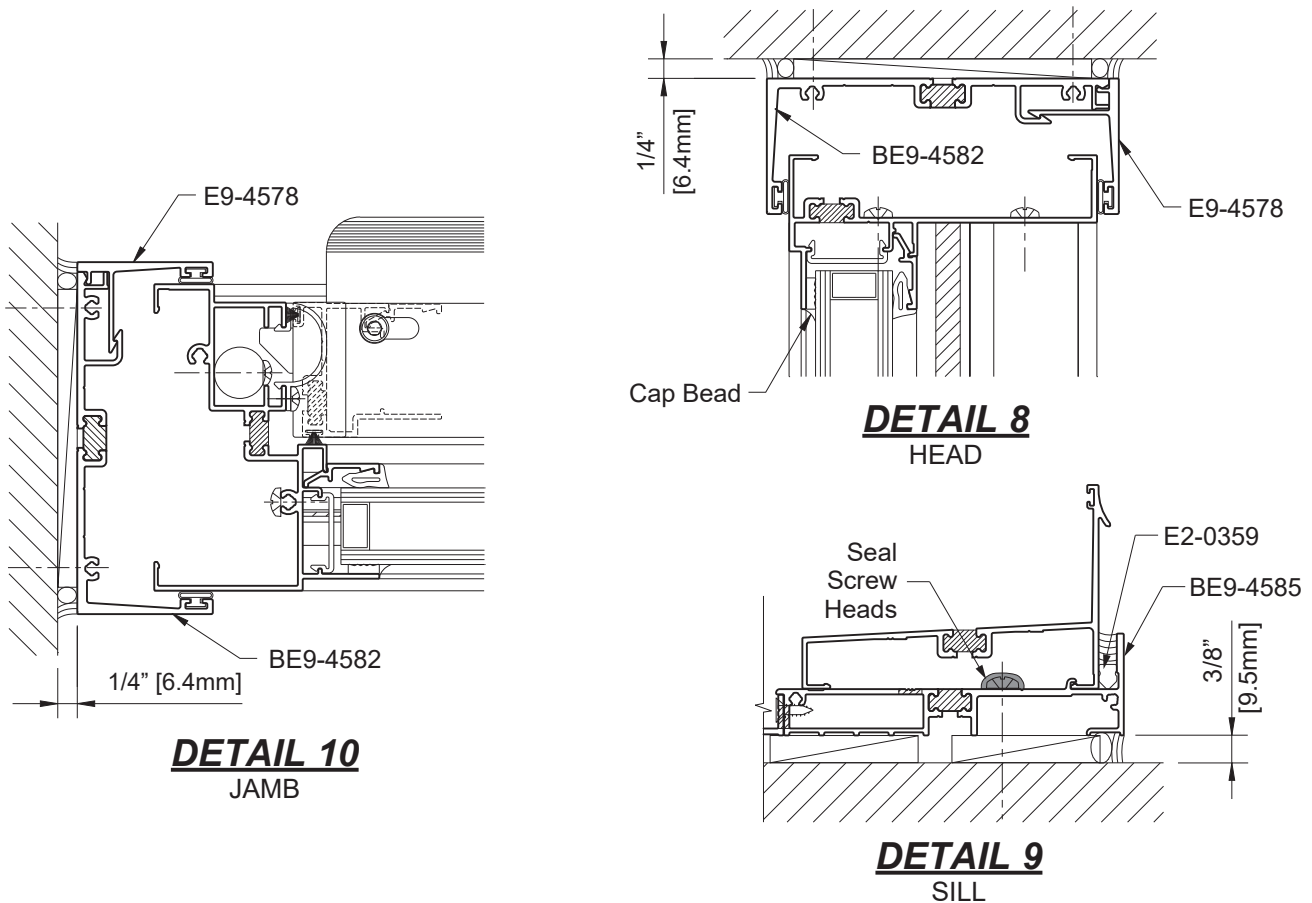

INSTALLATION

STEP 5 INSTALLATION OF STACKING MULLIONS

Refer to the **Window Accessories Installation Manual** for installation of optional stacking mullions.

CLEANING

STEP 6 CLEANING EXTERIOR OF WINDOW

1. Raise the lower sash 6" to 8".
2. Unlatch the tilt latch on both sides of the window top rail by loosening the allen head cap screws using a 3/16" allen wrench and sliding the cap screws towards the center of the sash. See **Picture 1**.
3. Carefully pull the top of the sash toward you.
4. If your window is equipped with SafSupport™ support arms you will need to disconnect them by lifting the locking tab, slightly raising the shoe, and pulling the arm toward the center of the window. Remember to hold on to the tilted sash at all times. See **Picture 2**.
5. Now lay the sash flat and clean the exterior side of the glass with normal glass cleaning product.
6. For double hung windows, you must lower the top sash 6" to 8" and repeat **Steps 6.1** thru **6.4**.
7. For single hung windows (fixed top lite), you must use a squeegee to reach the outside of the top sash. Remember to always protect yourself from falling out of the window while cleaning the top glass lite.
8. When finished cleaning, return all sash to their closed and locked position by reversing the procedure outlined above.



PICTURE 1



PICTURE 2

NOTE: DO NOT ATTEMPT TO REMOVE SASH FOR CLEANING!

RE-GLAZING

STEP 7 RE-GLAZING HUNG WINDOWS

1. Make sure the sash is closed and in the locked position.
2. Carefully remove all loose glass shards.
3. Remove interior wedge gaskets, glass stops and all remaining glass.
4. Remove all exterior glazing tape from glazing legs.
5. Wipe down the entire glass pocket with a 50% isopropyl alcohol/water mixture.
6. Dry the glazing area with a clean, soft cloth.
7. Install exterior glazing tape flush with the edge of the sash glazing leg; run the horizontal strips through and butt the vertical strips. Do not stretch the glazing tape when installing as it will shrink back causing a gap.
8. Peel off the tape adhesive backing to expose the interior side of the glazing tape.
9. Apply a toe bead using Tremco Tremsil® 600 sealant or equal around the perimeter of the exterior glazing tape. Make sure that the sealant fully contacts the glazing tape.

See **DETAILS 11 & 12.**

NOTE: Always replace with glass of the same thickness so the window will operate the same. Always use new exterior glazing tape. The glass stops and interior wedge gaskets maybe re-used but should be replaced if you see any damage.

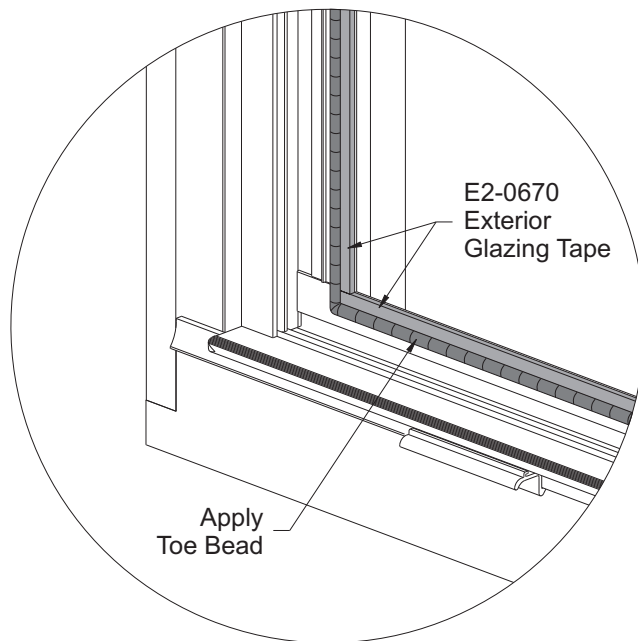

DETAIL 11

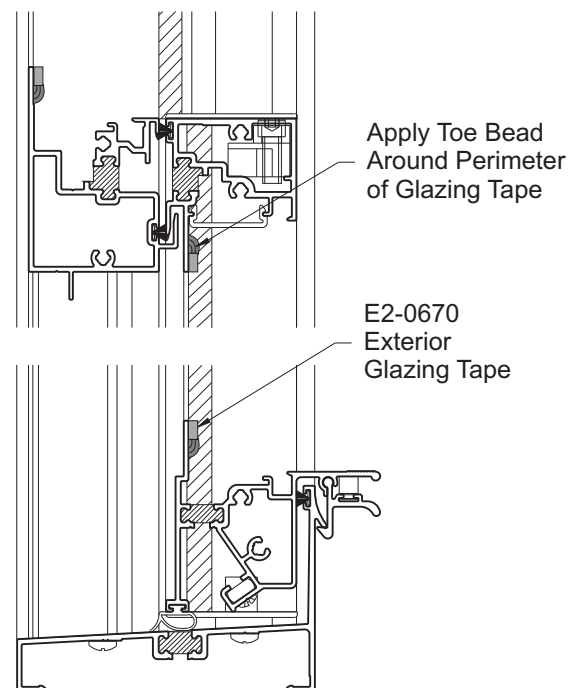

DETAIL 12

RE-GLAZING

**STEP 7 (Continued)
RE-GLAZING HUNG WINDOWS**

10. Place setting blocks on the sill of the sash and install new glass into the opening.
11. Insert horizontal and vertical glass stops and re-install the interior wedge gaskets.

See **DETAIL 13**.

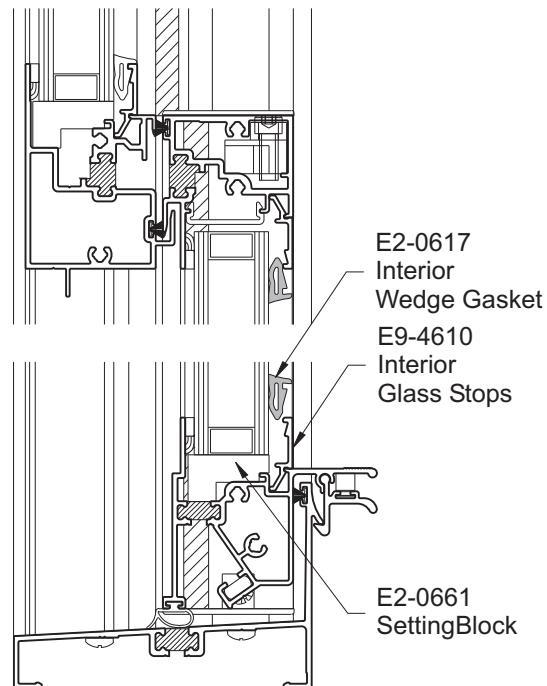

DETAIL 13

NOTE: Contact your local YKK AP service center if you have any questions concerning the proper replacement of glass in the YVS 400 TU hung window.

CALCULATING GLASS SIZES

ELEVATION		SINGLE HUNG	DOUBLE HUNG
FIXED GLASS SIZE	GLASS W	FW – 4 7/8" [123.8mm]	N/A
	GLASS H	FH/2 – 2 7/8" [73.0mm]	N/A
VENT GLASS SIZE	GLASS W	FW – 6 1/2" [165.1mm]	FW – 6 1/2" [165.1mm]
	GLASS H	FH/2 – 4" [101.6mm]	FH/2 – 4" [101.6mm]

BALANCE ADJUSTMENT / REPLACEMENT

STEP 8 DETERMINE BALANCE TYPE

NOTE: Replacing and/or adjusting the balances in your window can be hazardous and should only be attempted after completely reading the instructions and understanding each step. If you have any questions, please contact our nearest service center shown on our website www.ykkap.com.

1. First determine the type of balance you have by looking in the jamb of the window.
See **Picture 3**.
2. You will see one of three types of balances.
See **Picture 4**.
3. If you are having problems with block & tackle or UltraLift® type balances, you must replace the balance because they are not adjustable (See **Step 10 Balance Replacement**).
4. AlumaTilt® balances are adjustable by means of a winding tool.

NOTE: Never attempt to remove a spiral balance by removing the attaching screw before disconnecting the balance from the shoe.



PICTURE 3



PICTURE 4

BALANCE ADJUSTMENT / REPLACEMENT

STEP 9 SPIRAL BALANCE ADJUSTMENT

1. To start the adjustment process raise the sash to its highest point and then lower it approximately 12" and complete **Steps 6.2** thru **6.6** of the cleaning process.
2. Remove the plastic safety clip from the top of the balance shoe on both sides of the window.
See **Picture 5**.
3. Now remove the sash by lifting the tilt bar from the shoe one side at a time.
See **Picture 6**.
4. Using the winding tool hook, firmly grasp the lower roll pin on the spiral rod end and pull downward and toward you allowing the top roll pin to disconnect from the shoe.
See **Picture 7**.

NOTE: Do not allow the balance spiral rod to turn.

5. If your sash is drifting downward and/or hard to open, you must add turns to the spiral rod by turning the winding tool counter-clockwise. If your sash is hard to close and/or easy to open, then wind your spiral clockwise.
See **Picture 8**.

**NOTE: One or two turns is usually sufficient.
If you have two balances on each side,
both must be adjusted.**

6. Re-install the sash in the shoe, replace the safety clip, close and lock the sash in its normal, locked position.



PICTURE 5



PICTURE 6



PICTURE 7

BALANCE ADJUSTMENT / REPLACEMENT

**STEP 10
BALANCE REPLACEMENT**



PICTURE 8



PICTURE 9



PICTURE 10

1. To replace the balances follow **Steps 9.1** thru **9.4** of balance adjustment procedure.
2. Relax the tension on the balance and remove the attachment screw at the top of the balance.
See **Picture 9**.
3. Always replace the balances with balances of the same type and size unless directed otherwise by YKK AP. Use the same mounting hole for attachment screws.
4. Reconnect block and tackle balances to the shoe by slipping the clip into the shoe assembly.
See **Picture 10**.
5. Reconnect UltraLift® balances by pulling the rod down with the winding tool using the bottom roll pin and inserting the top roll pin into the tilt shoe.
See **Picture 7**.
6. Reconnect AlumiTilt® balances the same way as UltraLift® balances except that the balance must be wound before it is reconnected. A complete revolution counts a one wind. Contact YKK AP to determine how many winds are required.
7. Re-install the sash in the shoe, replace the safety clip, close and lock the sash in its normal, locked position.



101 Marietta Street NW
Suite 2100
Atlanta, Georgia 30303
www.ykkap.com