

## YFW 400 TU/TUH Window System

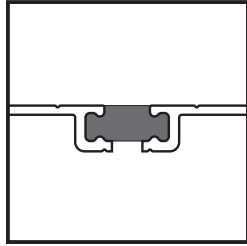

**ThermaBond Plus®**  
Poured & Debridged  
Technology

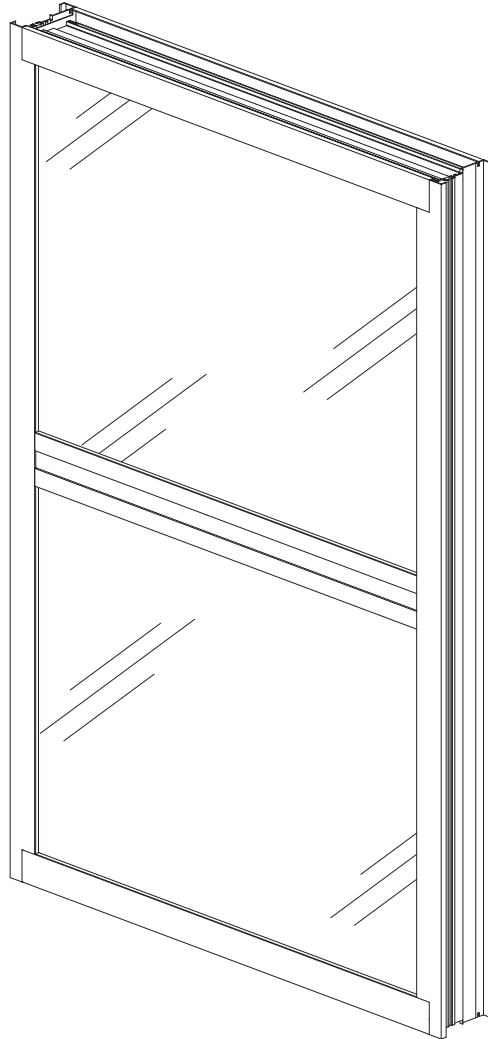

### YFW 400 TU SYSTEM DESCRIPTION

- 4" Overall Depth
- ThermaBond Plus® Poured & Debridged Thermal Break
- Integral Vertical and Horizontal Mullions (Non-Impact & Blast)
- Vertical & Horizontal Stacking Mullions (Non-Impact & Blast)

### YFW 400 TU/TUH PERFORMANCE FEATURES

- AAMA Performance Grade:  
– AW-PG100-FW

## Installation Manual



**TABLE OF CONTENTS**

Installation Notes ..... Page ii & iii  
Hardware ..... Page 1 & 2

**INSTALLATION**

Determine Window Reference Point ..... Page 3  
Determine Type of Anchors To Be Used ..... Page 3  
Installation Options and Procedures ..... Pages 4 & 5  
Installation of Vertical & Horizontal Stacking Mullions ..... Page 6

**RE-GLAZING**

Re-Glazing Fixed Windows ..... Pages 6 to 8  
Calculating Glass Sizes ..... Page 9  
Glazing Tables ..... Page 9

**INSTALLATION NOTES**









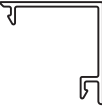
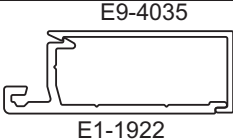

1. Do not drop, roll or drag boxes of aluminum framing. Move and stack boxes with proper support to prevent distortion. If fork lifts are used, be especially careful about striking the boxes when lifting or moving.
2. Store in a dry, out of the way area. If rain exposure, condensation or any water contact is likely, then all packaging material should be removed. Wet packaging materials will discolor and may stain aluminum finishes and paints.
3. All materials should be checked for quantity and quality upon receipt, YKK AP must be notified immediately of any discrepancies in shipment.
4. Check to make sure that you have the required shims, sealants, supplies, and tools necessary for the installation (not supplied by YKK AP).
5. Carefully check the openings and surrounding conditions that will receive your material. Remember, if the construction is not per the construction documents, it is your responsibility to notify the general contractor in writing. Any discrepancies must be brought to the general contractor's attention before you proceed with the installation.
6. Collect your shop drawings, materials, packing list, and this installation manual. Carefully review parts location, the sequence of installation, when you glaze it, and how you seal it. Installation instructions are of a general nature and may not cover every condition you will encounter. The shop drawings and/or installation manuals were prepared specifically for the product.
7. Any material substitutions must be of equal or greater quality.
8. Make certain that material samples have been sent for compatibility testing for all manufacturer's sealants involved. Make certain that sealants and backer rod have been installed in strict accordance with the manufacturer's recommendations and specifications.
9. Remember to isolate, in a approved manner, all aluminum from uncured masonry or other incompatible materials.
10. System-to-structure fasteners are not supplied by YKK AP. Fasteners called out on shop drawings are to indicate minimum sizes for design loading.
11. If any questions arise concerning YKK AP products or their installation, contact YKK AP for clarification before proceeding.

## INSTALLATION NOTES

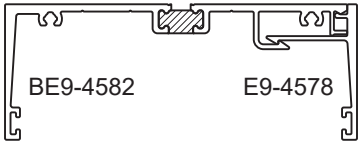
12. YKK AP window installation is typically completed before drywall, flooring and other products which may still be in process. Take the extra time to wrap and protect the work produced.
13. YKK AP Model YFW 400 TU/TUH windows are pre-finished, prefabricated, preassembled, products, shipped pre-glazed or open for field glazing and must be protected against damage.
14. Concrete, mortar, plaster, muriatic acid and other alkaline and acid based construction and cleaning materials may be very harmful to window finishes and should be removed with water and mild soap immediately or permanent damage or staining of the finishes will occur. A spot test is recommended before any cleaning agent is used, and abrasive type cleaners must never be used.
15. Windows are never to be used as ladders, step stools, scaffolds, scaffold supports, or as pass through openings for materials.
16. All work must start from, and be referenced to benchmarks, offset lines and/or column centerlines established by the architectural drawings and the general contractor.
17. All windows must be installed plumb, square, level and true, and in accordance with approved shop drawings and these installation instructions.
18. Install all windows in accordance with their mark and type per approved shop drawings.
19. The glass has been specified by shop drawings and YKK AP is not responsible for conformance with local building codes other than to provide the approved glass. It is the installers' responsibility to ensure final compliance of the glazing with all applicable codes.
20. Check our website, [www.ykkap.com](http://www.ykkap.com), for the latest installation manual update prior to commencing work.





**HARDWARE & ACCESSORIES**

NAME	DETAIL	DESCRIPTION	MATERIAL
GLASS STOP E9-5730		For non-impact and Small Missile applications.	ALUMINUM
GLASS STOP E9-5731		Anchored to frame for Large Missile and blast applications.	ALUMINUM
GLASS STOP COVER E9-5732		Use with glass stop E9-5731.	ALUMINUM
ANCHOR CLIP E1-1922 and COVER E9-4035	 E9-4035 E1-1922	Used to anchor frame to structure.	ALUMINUM
STRAP ANCHOR E1-1921 / BE9-8567 and COVER E9-8431	 BE9-8567 (Continuous) E1-1921 (2" Long Clips) E9-8431	Used to anchor frame to structure.	ALUMINUM
HEAD / JAMB RECEPTOR BE9-4582 and SNAP COVER E9-4578	 BE9-4582      E9-4578	Used to anchor frame to structure. Used with E2-0051 airtight gasket.	ALUMINUM
TWIST STRAP ANCHOR E1-1972		Used to anchor frame to structure.	GALVANIZED STEEL
SETTING BLOCK E2-0104		Used to block glass for proper glazing.	BLACK EPDM
WEDGE GASKET E2-0672		Push-in gasket used for primary window glazing	BLACK EPDM
GLAZING TAPE E2-0670		Used to space between glazing and frame prior to application of cap bead.	POLYURETHANE FOAM
AIRTIGHT GASKET E2-0051		Used with BE9-4582 head/jamb receptor and E9-4578 snap cover.	SANTOPRENE

## HARDWARE & ACCESSORIES

NAME	DETAIL	DESCRIPTION	MATERIAL
GLAZING SPACER E2-0350		Used with E9-5731 to hold glass in place prior to cap bead for impact and blast applications.	BLACK EPDM

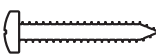
## FASTENERS

PART NUMBER	DETAIL	DESCRIPTION	MATERIAL
PC1020-SS		<b>#10 X 1-1/4" PHMS</b> Type AB, for frame assembly.	STAINLESS STEEL
PS1010-SS		<b>#10 X 5/8" PPH</b> Type AB, Self-drilling, #3 point, for attachment of E9-5731 glass stop. Use for field glazing.	SERIES 410 STAINLESS STEEL
PC1008-SS		<b>#10 X 1/2" PHSMS</b> Type AB, for attachment of E9-5731 glass stop. Use for shop glazing.	STAINLESS STEEL



## INSTALLATION

### STEP 1 DETERMINE WINDOW REFERENCE POINT

Establish the window reference lines or the exterior/interior plane of the windows to be installed using either bench marks, offset lines, or column centerlines provided by the general contractor and referenced on the shop drawings. Use the established reference points to determine the installation points for each window opening at the head, jambs, and sill.

### STEP 2 DETERMINE THE TYPE OF WINDOW ANCHORS TO BE USED

The type of window anchoring used will depend upon the job conditions and the installer's preference. No. 10 fasteners are to be the minimum size used; consult the shop drawings and engineering calculations as the project conditions may require larger fasteners.

Location of fasteners:

- A maximum of 3" from the corner of all box trim and receptors.
- At 15" on center for balance of fasteners.

See **DETAILS 1, 2, 3, & 4.**

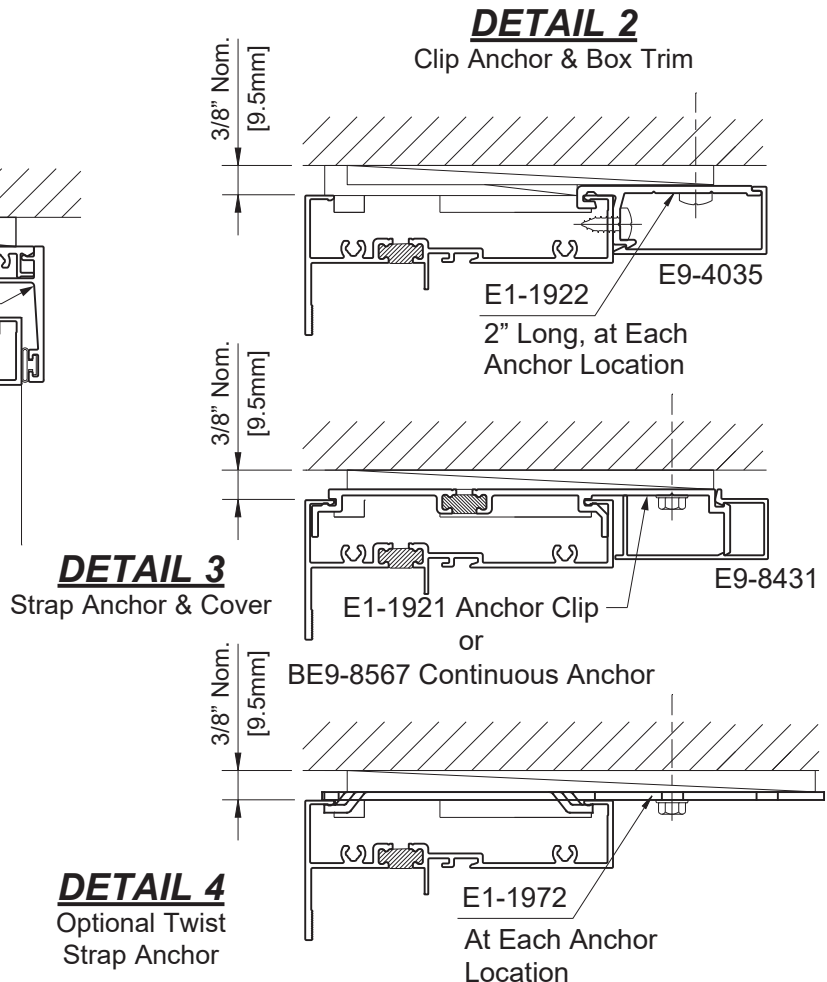
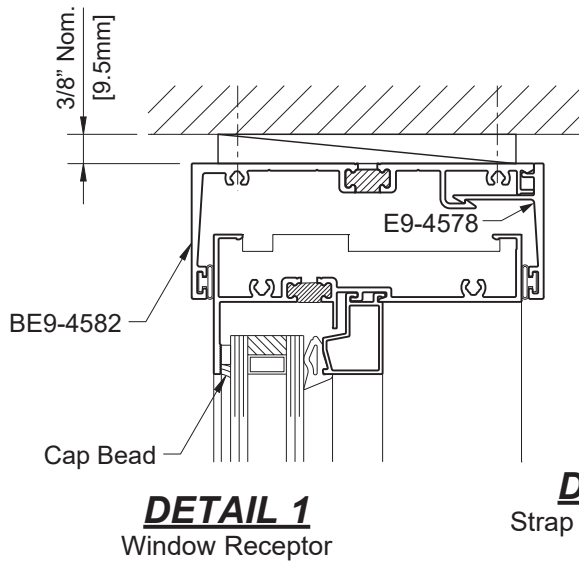

## INSTALLATION

### STEP 2 (Continued)

Refer to the specific fastener manufacturer's recommendations for proper edge distance and spacing for masonry applications.

**CAUTION:** Do not fasten ceiling support angles, blind pockets, drapery tracks, convactor covers or stools to the windows or the receptors. The window system is not designed to support the additional load and must be free to expand and contract under normal thermal cycling conditions.

### STEP 3 INSTALLATION OPTIONS AND PROCEDURES

**Install window receptor system at the head only or at the head & jambs:**

1. Refer to **Step 2** or structural calculations to determine the size and location of fasteners (minimum #10 fasteners).
2. Shim and secure the exterior leg of receptor(s) using the required fasteners.
3. When receptors are used at both the head and the jamb, the head receptor will run through and sill starter, BE9-4585, should be used as shown.
4. Seal the intersection of receptors and all fasteners in sill starter.
5. Install the window frame into the opening.
6. Shim the sill and jambs of the window to ensure that they are installed plumb, square, level and true.
7. Snap in interior receptor leg(s).
8. Install backer rod and apply perimeter sealant as shown.  
Tool the sealant to ensure a water tight joint.

See **DETAILS 5** through **7** on **Page 5**.

## INSTALLATION

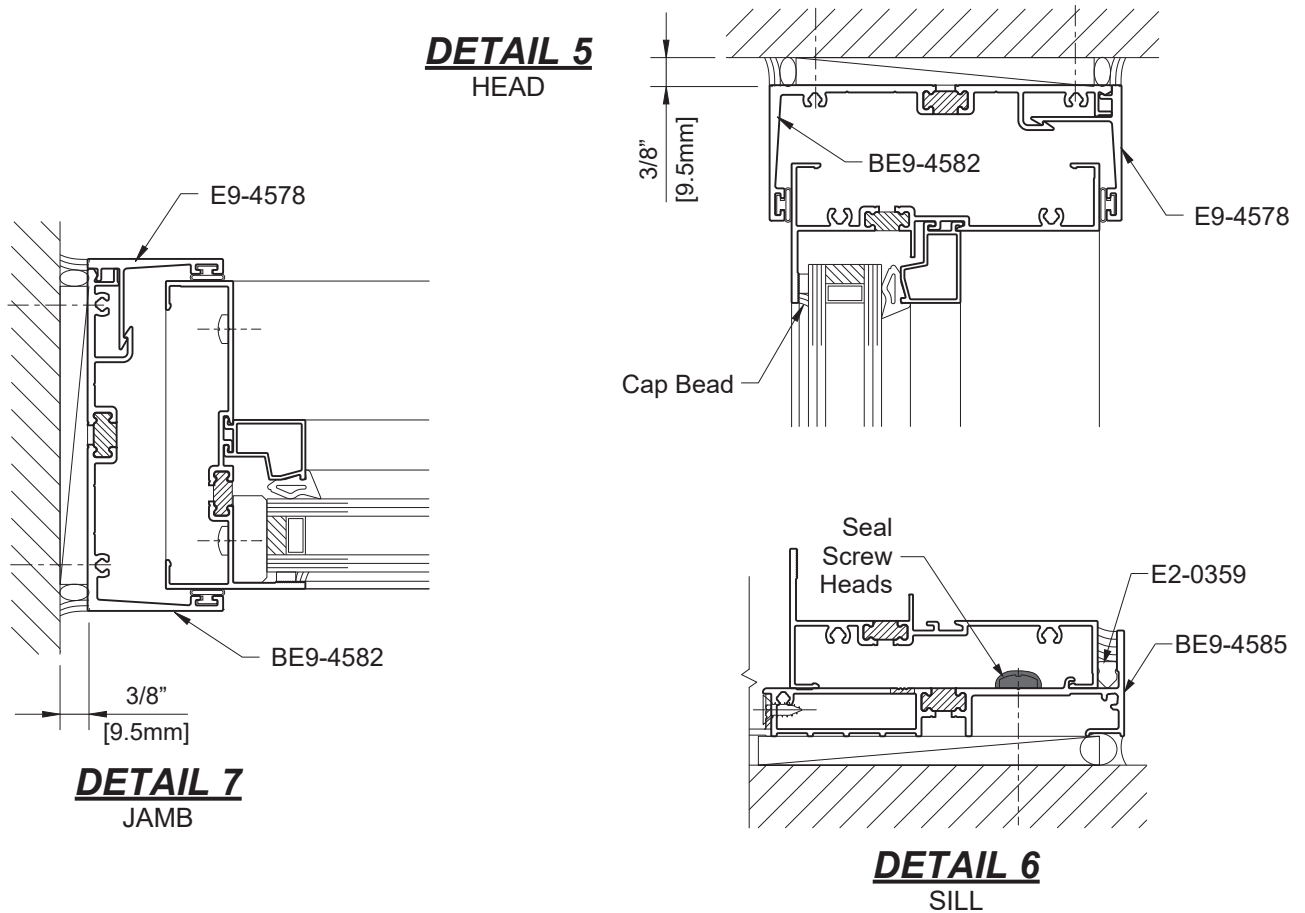

Refer to **Window Accessories Installation** manual for additional information and details.

**INSTALLATION****STEP 4  
INSTALLATION OF STACKING MULLIONS**

Refer to the **Window Accessories Installation Manual** for installation of optional stacking mullions.

**GLAZING / RE-GLAZING****STEP 5  
GLAZING / RE-GLAZING****Optional Weep Hole Baffles when using Sill Flashing:**

- Prior to field glazing fixed lites, adhere a weep baffle (E2-0772) with sealant, over the weep hole in the sill, centered on the weep hole.
- Tool the excess sealant after application.

See **Detail 8**.

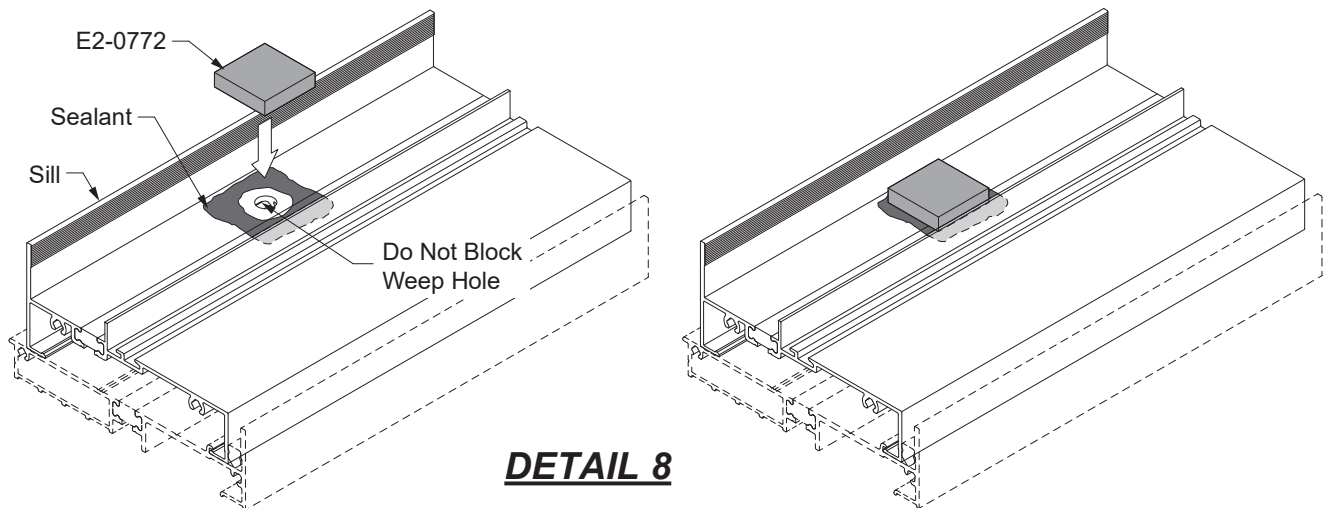

## GLAZING / RE-GLAZING

### STEP 5 (Continued)

#### GLAZING / RE-GLAZING

**Note:** If window was shipped unglazed, please begin with number 4.

1. Carefully remove all loose glass shards.
2. Remove interior wedge gaskets, glass stops and all remaining glass.
3. Remove all exterior glazing tape from glazing legs.
4. Wipe down the entire glass pocket with a 50% isopropyl alcohol/water mixture.
5. Dry the glazing area with a clean, soft cloth.
6. Apply and tool sealant (Tremco Tremsil® 600 or equivalent) to the interior corners of the frame as shown in **Detail 9**.
7. Wipe the sealant off where the glazing tape, E2-0670, is to be adhered.
8. Install exterior glazing tape 1/8" inward from the edge of the glazing leg; run the horizontal strips through and butt the vertical strips. Do not stretch the glazing tape when installing as it will shrink back causing a gap.
9. Peel off the tape adhesive backing to expose the interior side of the glazing tape.

See **DETAILS 9 & 10**.

**Note:** Always replace with glass of the same thickness.

Always use new exterior glazing tape. The glass stops and interior wedge gaskets maybe re-used but should be replaced if you see any damage.

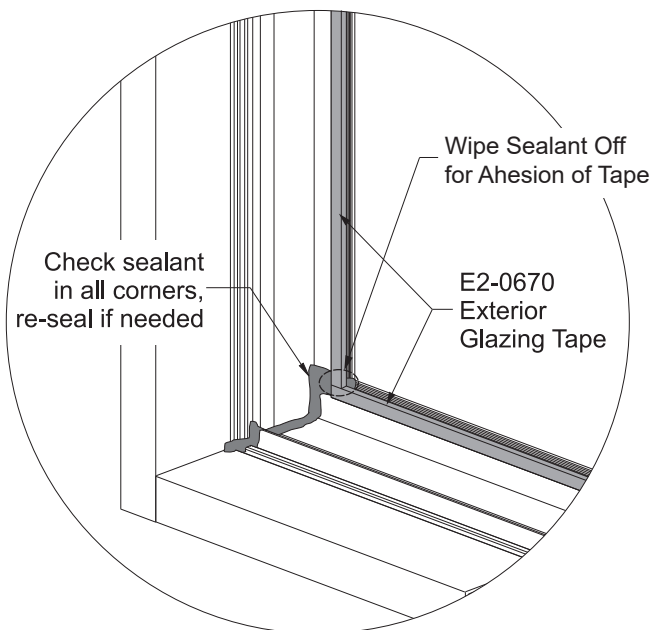

**DETAIL 9**

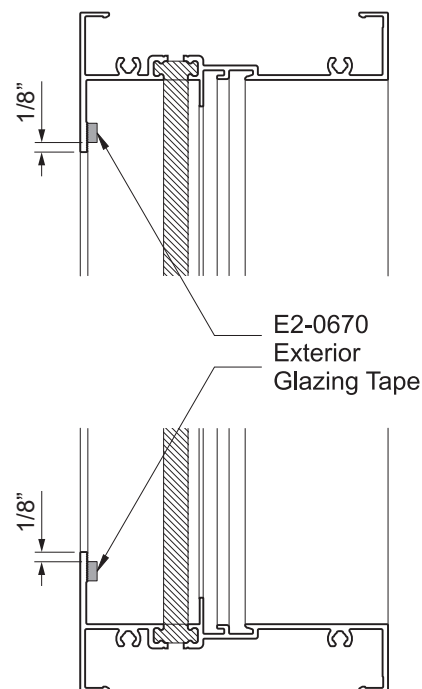

**DETAIL 10**

**GLAZING / RE-GLAZING**

**STEP 5 (Continued)  
RE-GLAZING**

10. Place setting blocks on the sill of the window and install new glass into the opening.
11. Insert horizontal and vertical glass stops and re-install the interior wedge gaskets for non-impact and Small Missile applications.
12. Fasten glass stop in place, snap on cover, and insert glazing spacer. Follow with silicone sealant. for Large Missile and blast applications.
13. Apply a cap bead using Tremco Tremsil® 600 sealant or equal around the perimeter of the exterior glazing tape. Make sure that the sealant fully contacts the glazing tape. The cap bead should cover at least 50% of the external glazing leg.

See **DETAILS 11 and 12.**

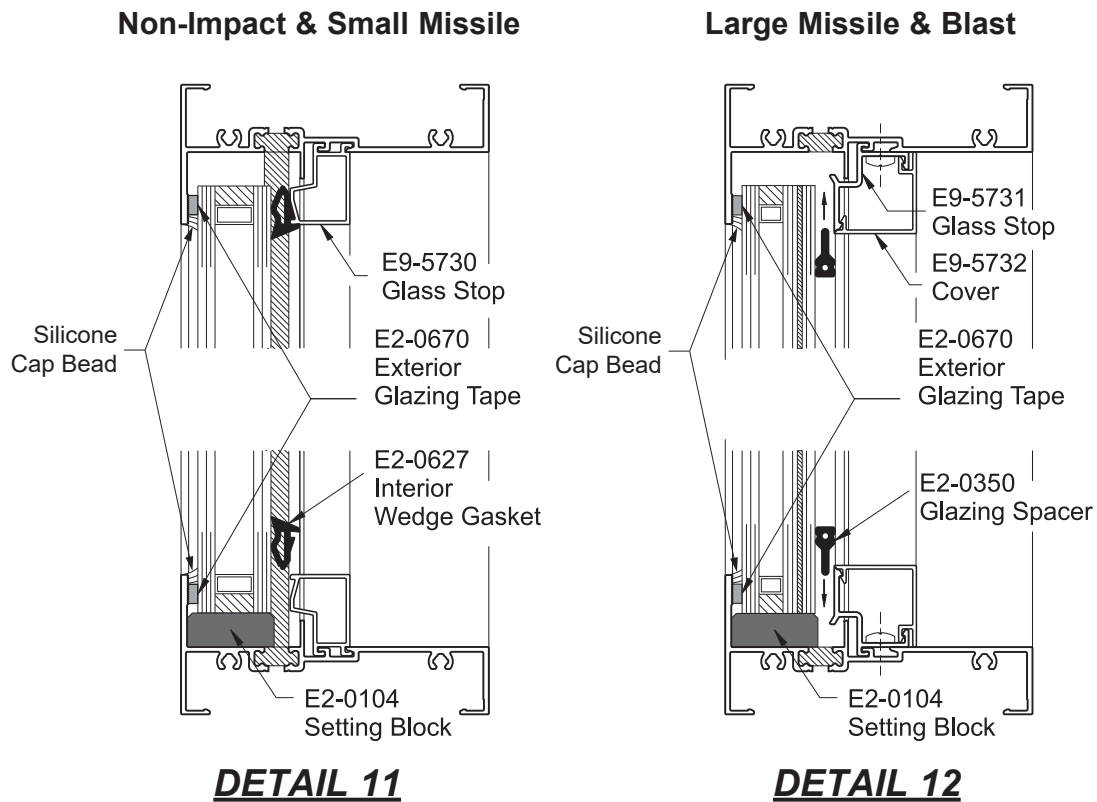

**NOTE: Contact your local YKK AP service center if you have any questions concerning the proper replacement of glass in the YFW 400 TU/TUH fixed window.**

**CALCULATING GLASS SIZES**

<b>ELEVATION</b>				
		<b>FIXED GLASS SIZE</b>	<b>GLASS W</b>	FW – 2-5/8" [66.7mm]
	<b>GLASS H</b>	FH – 2-5/8" [66.7mm]	h1,h2 – 2-5/16" [58.8mm]	FH – 2-5/8" [66.7mm]

**GLAZING TABLES**

**NON-IMPACT GLAZING**

GLASS/PANEL DEPTH	EXTERIOR		INTERIOR	
	F.C.	BACKER TAPE	F.C.	WEDGE GASKET
15/16"	1/8"	E2-0670	5/16"	E2-0160
1"			1/4"	E2-0672
11/16"			3/16"	E2-0671
1 1/8"			1/8"	E2-0630

**IMPACT & BLAST GLAZING**

GLASS/PANEL DEPTH	GLAZING TYPE	EXTERIOR		INTERIOR	
		F.C.	BACKER TAPE	F.C.	GASKET/SPACER
1"(NOMINAL)	LARGE MISSILE	1/8"	E2-0670	1/4"	E2-0350
1"(NOMINAL)	SMALL MISSILE			1/4"	E2-0672
1"(NOMINAL)	BLAST			1/4"	E2-0350



101 Marietta Street NW  
Suite 2100  
Atlanta, Georgia 30303  
[www.ykkap.com](http://www.ykkap.com)