

YVS 410 TUH Window System

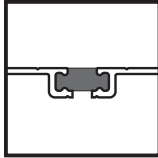

**ThermaBond Plus®
Poured & Debridged
Technology**

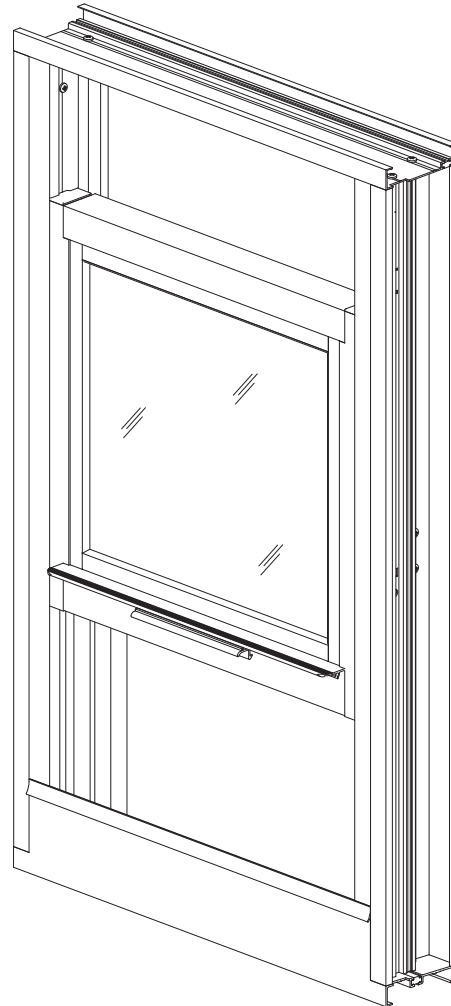

SINGLE HUNG

YVS 410 TUH SYSTEM DESCRIPTION

- 4" Overall Depth
- ThermaBond Plus™ Poured & Debridged Thermal Break
- Variations: Side Load Single Hung
- 1" Large & Small Missile Glazing
- Optional Screens

YVS 410 TUH PERFORMANCE FEATURES

- TAS 201-202-203, +80/-120 PSF
- Factory Notched, Butted, Mechanically Fastened & Sealed
- Large & Small Missile Single Hung

Installation Manual

This page intentionally left blank.

TABLE OF CONTENTS

Installation Notes Page ii & iii

INSTALLATION

Determine Window Reference Point Page 1
Determine Type of Anchors To Be Used Pages 1 & 2
Installation Options and Procedures Page 2
Installation of Stacking Mullions Page 3

CLEANING

Cleaning Exterior of Window Page 3

RE-GLAZING

Re-Glazing Hung Windows Pages 4 & 5
Calculating Glass Sizes Page 6

BALANCE REPLACEMENT

Determine Balance Type Page 7
Balance Replacement Page 8

INSTALLATION NOTES

1. Do not drop, roll or drag boxes of aluminum framing. Move and stack boxes with proper support to prevent distortion. If fork lifts are used, be especially careful about striking the boxes when lifting or moving.
2. Store in a dry, out of the way area. If rain exposure, condensation or any water contact is likely, then all packaging material should be removed. Wet packaging materials will discolor and may stain aluminum finishes and paints.
3. All materials should be checked for quantity and quality upon receipt, YKK AP must be notified immediately of any discrepancies in shipment.
4. Check to make sure that you have the required shims, sealants, supplies, and tools necessary for the installation (not supplied by YKK AP).
5. Carefully check the openings and surrounding conditions that will receive your material. Remember, if the construction is not per the construction documents, it is your responsibility to notify the general contractor in writing. Any discrepancies must be brought to the general contractor's attention before you proceed with the installation.
6. Collect your shop drawings, materials, packing list, and this installation manual. Carefully review parts location, the sequence of installation, when you glaze it, and how you seal it. Installation instructions are of a general nature and may not cover every condition you will encounter. The shop drawings and/or installation manuals were prepared specifically for the product.
7. Any material substitutions must be of equal or greater quality.
8. Make certain that material samples have been sent for compatibility testing for all manufacturer's sealants involved. Make certain that sealants and backer rod have been installed in strict accordance with the manufacturer's recommendations and specifications.
9. Remember to isolate, in a approved manner, all aluminum from uncured masonry or other incompatible materials.
10. System-to-structure fasteners are not supplied by YKK AP. Fasteners called out on shop drawings are to indicate minimum sizes for design loading.
11. If any questions arise concerning YKK AP products or their installation, contact YKK AP for clarification before proceeding.

INSTALLATION NOTES

12. YKK AP window installation is typically completed before drywall, flooring and other products which may still be in process. Take the extra time to wrap and protect the work produced.
13. YKK AP Model YVS 410 TUH windows are pre-finished, prefabricated, preassembled, and preglazed products, and must be protected against damage.
14. Concrete, mortar, plaster, muriatic acid and other alkaline and acid based construction and cleaning materials may be very harmful to window finishes and should be removed with water and mild soap immediately or permanent damage or staining of the finishes will occur. A spot test is recommended before any cleaning agent is used, and abrasive type cleaners must never be used.
15. Windows are never to be used as ladders, step stools, scaffolds, scaffold supports, or as pass through openings for materials.
16. All work must start from, and be referenced to benchmarks, offset lines and/or column centerlines established by the architectural drawings and the general contractor.
17. All windows must be installed plumb, square, level and true, and in accordance with approved shop drawings and these installation instructions.
18. Install all windows in accordance with their mark and type per approved shop drawings.
19. The glass has been specified by shop drawings and YKK AP is not responsible for conformance with local building codes other than to provide the approved glass. It is the installers' responsibility to ensure final compliance of the glazing with all applicable codes.
20. Check our website, www.ykkap.com, for the latest installation manual update prior to commencing work.
21. For additional information, refer to the **Window Products Maintenance Manual**.

This page intentionally left blank.

INSTALLATION

STEP 1 DETERMINE WINDOW REFERENCE POINT

Establish the window reference lines or the exterior/interior plane of the windows to be installed using either bench marks, offset lines, or column centerlines provided by the general contractor and referenced on the shop drawings. Use the established reference points to determine the installation points for each window opening at the head, jambs, and sill.

STEP 2 DETERMINE THE TYPE OF WINDOW ANCHORS TO BE USED

The type of window anchoring used will depend upon the job conditions. Quarter-inch diameter fasteners are to be the minimum size used; consult the shop drawings and engineering calculations. Refer to FPA FL12878, drawing YKK061 for additional information.

Location of fasteners:

- A maximum of 4" from the corner of all box trims.
- Refer to FPA or Engineer of Record for fastener spacing.

*Refer to FPA for additional approved box trims.

See **DETAILS 1, 2, 3, & 4.**

Refer to **Window Accessories Installation** manual for additional information and details.

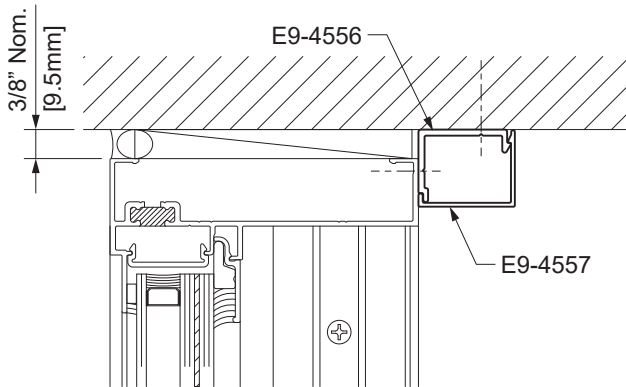

DETAIL 1
Box Trim *

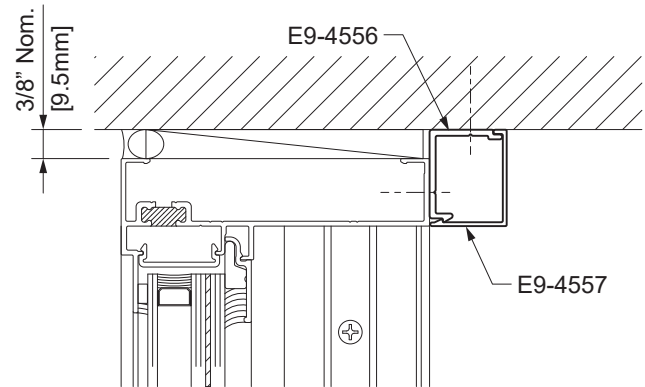

DETAIL 2
Box Trim *

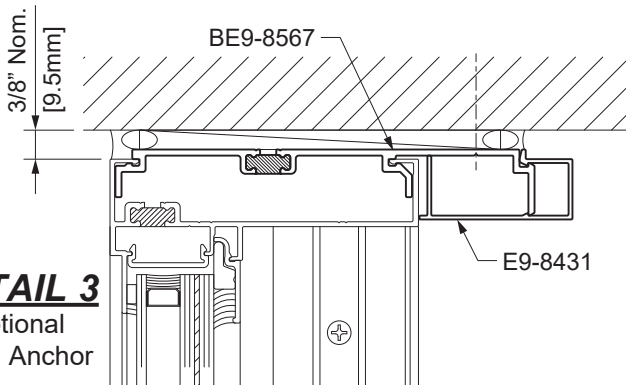

DETAIL 3
Optional
Strap Anchor

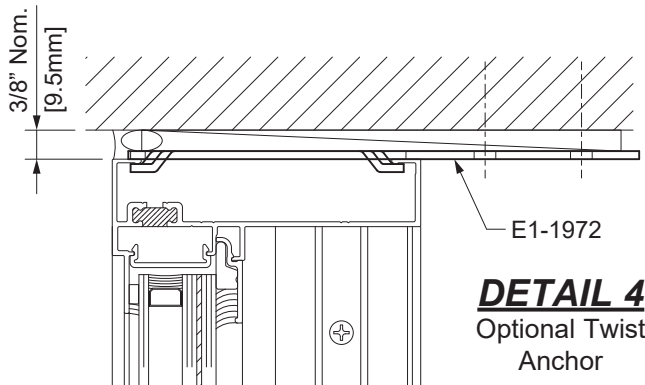

DETAIL 4
Optional Twist
Anchor

INSTALLATION

STEP 2 (Continued)

DETERMINE THE TYPE OF WINDOW ANCHORS TO BE USED

Refer to the specific fastener manufacturer's recommendations for proper edge distance and spacing for masonry applications.

CAUTION: Do not fasten ceiling support angles, blind pockets, drapery tracks, convactor covers or stools to the windows or the receptors. The window system is not designed to support the additional load and must be free to expand and contract under normal thermal cycling conditions.

STEP 3

VENTILATOR INSTALLATION AND ADJUSTMENT

All sliding sashes and components must be checked for proper alignment, margins, and operation.

- All hardware must be cleaned and lubricated as necessary to provide smooth operation.
- Refer to **Window Products Maintenance Manual** for additional maintenance requirements and glass replacement.

STEP 4

INSTALLATION OPTIONS AND PROCEDURES

OPTION 1: Anchor with standard box trim:

1. Install the frame plumb, square, level and true.
 - Refer to **Step 2** or structural calculations for fastener size and location.
 - Shim as required along the frame.
2. Install backer rod and seal with a quality perimeter sealant.

See **DETAILS 1** through **4**.

Note: When installing YVS 410 TUH windows with 3/8" caulk joint, box trim members E9-4556 & E9-4557 must be oriented as shown in **DETAILS 1 & 2**. (Refer to FPA for additional approved box trim.)

INSTALLATION

STEP 5 INSTALLATION OF STACKING MULLIONS

Refer to the **Window Accessories Installation Manual** for installation of optional stacking mullion.

CLEANING

STEP 6 CLEANING EXTERIOR OF WINDOW

This window requires cleaning from the exterior.

NOTE: DO NOT ATTEMPT TO REMOVE SASH FOR CLEANING!

RE-GLAZING

STEP 7 RE-GLAZING HUNG WINDOWS

1. Make sure the sash is closed and in the locked position.
2. Carefully remove all loose glass shards.
3. Remove interior wedge gaskets, glass stops, structural sealant, and all remaining glass.
4. Remove all exterior glazing tape from glazing legs.
5. Wipe down the entire glass pocket with a 50% isopropyl alcohol/water mixture.
6. Dry the glazing area with a clean, soft cloth.
7. Install exterior glazing tape, E2-0670, on all four sides:
 - Leave a 1/8" gap between the edge of the tape and the edge of the ventilator.
 - Make certain that the corners of the tape do not overlap as this will prevent full contact around the perimeter of the glass.
8. Peel off the tape adhesive backing 3" to 4" at each corner and fold them towards the inside of the vent.
9. Place setting blocks at quarter points on the sill of the sash and install new glass into the opening.

See **DETAILS 5, 6, 7 & 8.**

NOTE: Always replace with glass of the same thickness so the window will operate the same. Always use new exterior glazing tape. The setting blocks, glass stops, and interior wedge gaskets maybe re-used but should be replaced if you see any damage.

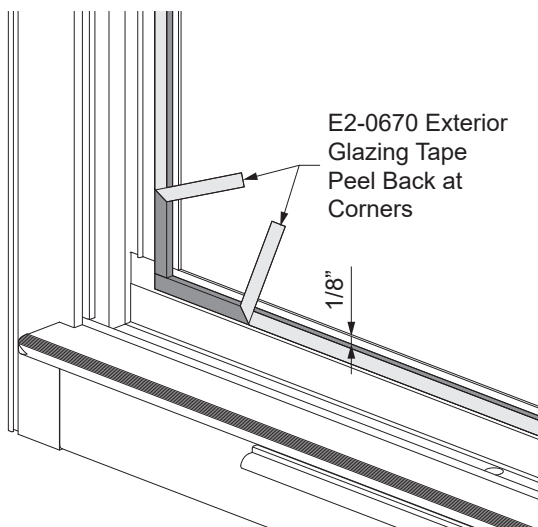

DETAIL 5

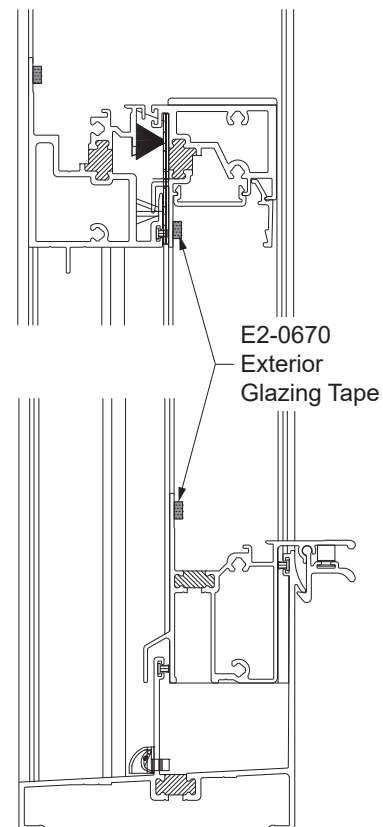

DETAIL 6

RE-GLAZING

STEP 7 (Continued) RE-GLAZING HUNG WINDOWS

10. Remove glazing tape backing from all sides by gently pulling the tape from between the glass and vent. Press the glass firmly against the tape surface.
11. For small missile: Insert horizontal and vertical glass stops and re-install the E2-0617 continuous interior wedge gaskets.
For large missile: Insert horizontal and vertical glass stops, reinstall the continuous E2-0668 spacer, and apply structural silicone sealant. Tool the sealant as required.
12. Apply a cap bead using Tremco Tremsil® 600 sealant or equal around the perimeter of the exterior glazing tape. Make sure that the sealant fully contacts the glazing tape and glass.

See **DETAILS 7 & 8.**

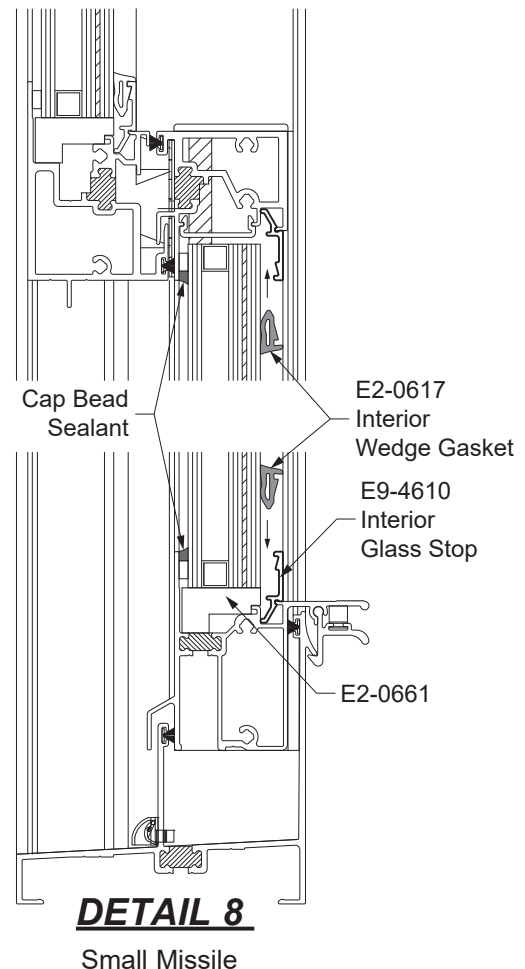
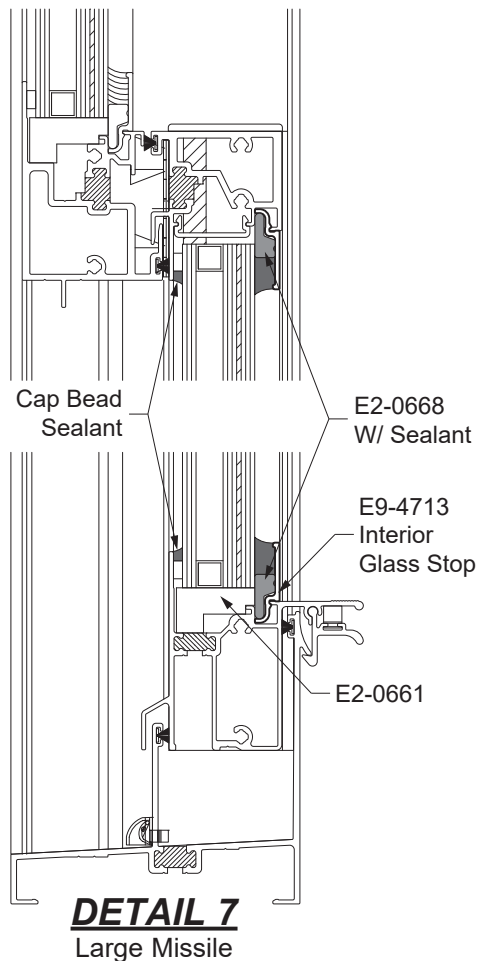

NOTE: Contact your local YKK AP service center if you have any questions concerning the proper replacement of glass in the YVS 410 TUH hung window.

CALCULATING GLASS SIZES

HUNG WINDOW-STANDARD JAMB TYPE (W/ B&T BALANCE)

		SINGLE HUNG
ELEVATION		
FIXED GLASS SIZE	GLASS W	FW - 4 ¹ / ₈ " [104.8]
	GLASS H	FH/2 - 3 ¹ / ₄ " [82.6]
VENT GLASS SIZE	GLASS W	FW - 6 ¹ / ₈ " [155.6]
	GLASS H	FH/2 - 4 ³ / ₈ " [111.1]

HUNG WINDOW-OPTION JAMB TYPE (W/ ULTRA-LIFT)

		SINGLE HUNG
ELEVATION		
FOR OPTION JAMB		
FIXED GLASS SIZE	GLASS W	FW - 5 ¹ / ₂ " [139.7]
	GLASS H	FH/2 - 3 ¹ / ₄ " [82.6]
VENT GLASS SIZE	GLASS W	FW - 7 ¹ / ₂ " [190.5]
	GLASS H	FH/2 - 4 ³ / ₈ " [111.1]

BALANCE REPLACEMENT

STEP 8 DETERMINE BALANCE TYPE

NOTE: Replacing the balances in your window can be hazardous and should only be attempted after completely reading the instructions and understanding each step. If you have any questions, please contact our nearest service center shown on our website www.ykkap.com.

1. First determine the type of balance you have by looking in the jamb of the window.
See **Picture 1**.
2. You will see one of two types of balances.
See **Picture 2**.
3. If you are having problems with block & tackle or UltraLift® type balances, you must replace the balance because they are not adjustable. Always replace both balances.
4. (See **Step 9 Balance Replacement**).

NOTE: Never attempt to remove a spiral balance by removing the attaching screw before disconnecting the balance from the shoe.



PICTURE 1

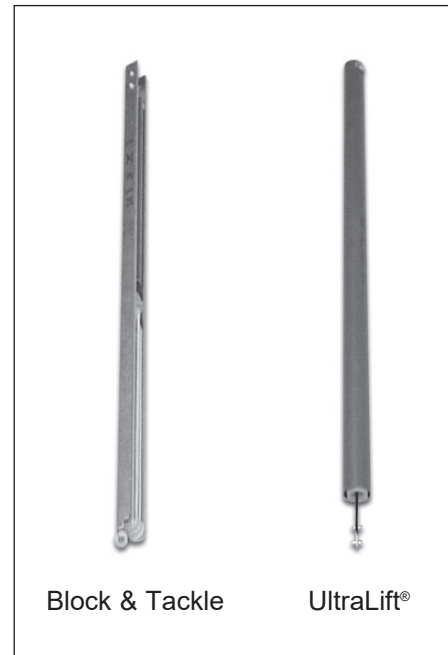

PICTURE 2

BALANCE REPLACEMENT**STEP 9
BALANCE REPLACEMENT****PICTURE 3****PICTURE 4****PICTURE 5****PICTURE 6**

1. Relax the tension on the balance and remove the attachment screw at the top of the balance.
See **Picture 5**.
2. Always replace the pair of balances with balances of the same type and size unless directed otherwise by YKK AP. Use the same mounting hole for attachment screws.
3. Reconnect block and tackle balances to the shoe by slipping the clip into the shoe assembly.
See **Picture 6**.
4. Reconnect UltraLift[®] balances by pulling the rod down with the winding tool using the bottom roll pin and inserting the top roll pin into the shoe.
See **Picture 3 & 4**.
5. Replace the safety clip, close and lock the sash in its normal, locked position.

This page intentionally left blank.



101 Marietta Street NW
Suite 2100
Atlanta, Georgia 30303
www.ykkap.com