

Note: It is recommended to perform this procedure on a workbench before installing the windows into the frame opening.

STEP 1 PREPARE THE WINDOW AND FACTORY MULLION FOR INSTALLATION

- Cut off the nail fin on the window where the factory mullion is to be installed. Ensure it is flush with the window frame.
 - Also cut off the exterior corner cavity on that same side, first at the groove and then at the face of the jamb.
- See **Detail 1**.

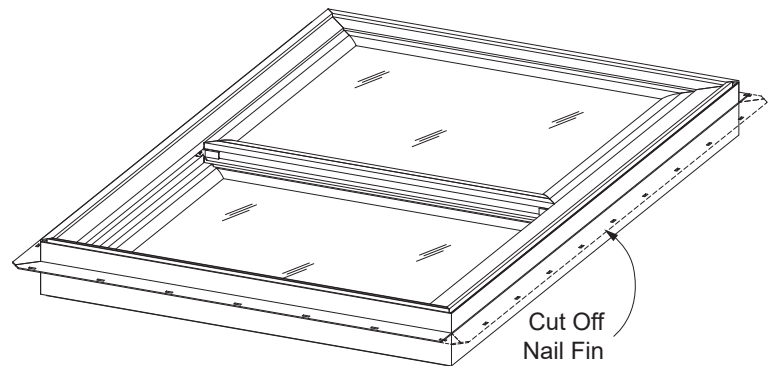
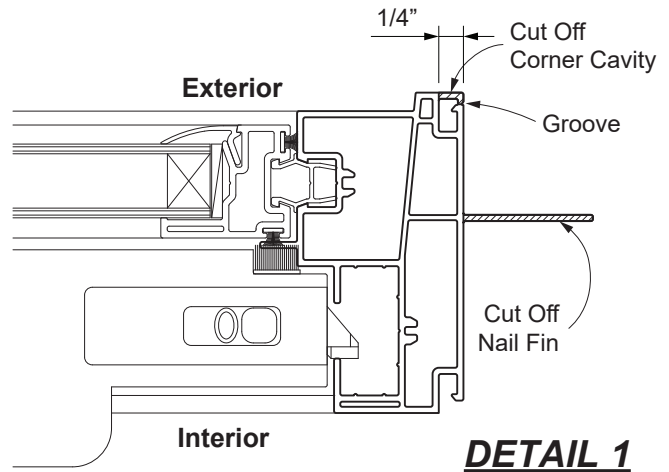

- Cut the factory mullion halves to window frame height minus (-) 1".
 - Drill 0.189" diameter clear holes into the mullion rear half, at 1-1/2" from each end and at 9" maximum on center.
 - For each screw hole drill a 0.354" diameter access hole.
- See **Detail 2**.

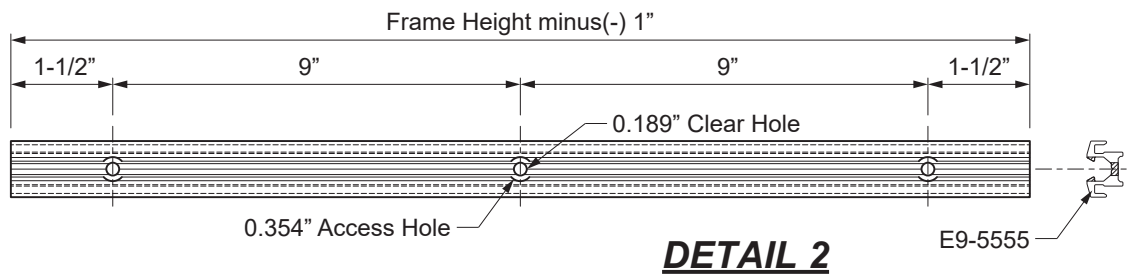

STEP 1 (Continued) PREPARE THE WINDOW AND FACTORY MULLION FOR INSTALLATION

-Cut two V-gaskets (2K-21083) also to window frame height minus (-) 1".

-Insert the V-gaskets into the reglets on each factory mullion front, taking care to ensure the proper orientation as shown in **Detail 2**.

-Apply continuous sealant to the engagement areas of the exterior factory mullion as shown in **Detail 3**.

Window Interior

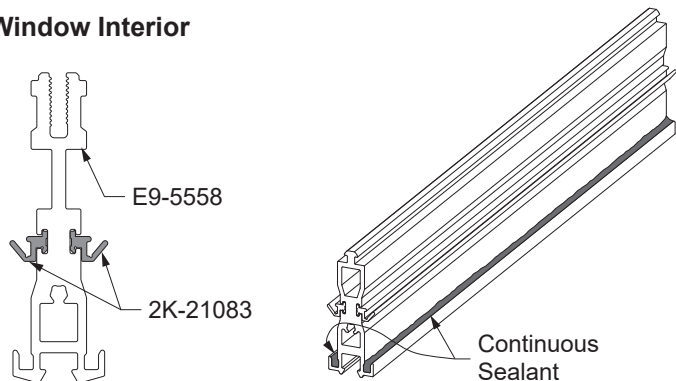

DETAIL 3

DETAIL 4

STEP 2 INSTALL THE EXTERIOR FACTORY MULLION TO THE 1ST WINDOW

-Hook the exterior factory mullion onto the window jamb, centered along the frame height, and rotate it into position. Keep the mullion supported until both exterior and interior mullion halves are installed.

See **Detail 5**.

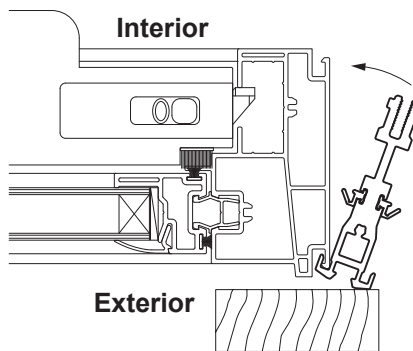

DETAIL 5

STEP 3 INSTALL THE EXTERIOR FACTORY MULLION TO THE 1ST WINDOW

-Hook the other window onto the exterior factory mullion, and rotate it into place, keeping both windows supported.

See **Detail 6**.

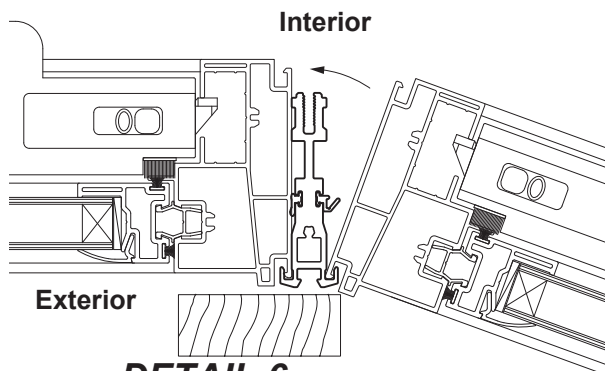

DETAIL 6

STEP 4 PREPARE THE INTERIOR MULLION FOR INSTALLATION

-Apply continuous sealant to the engagement areas of the interior factory mullion as shown in **Detail 7**.

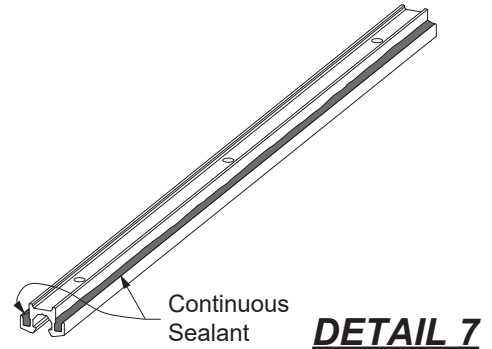

STEP 5 INSTALL THE INTERIOR FACTORY MULLION

-Fasten the interior factory mullion into place with FF-0812-SS, centered on the window frame height, ensuring proper engagement with both windows and the exterior factory mullion. See **Detail 8**.

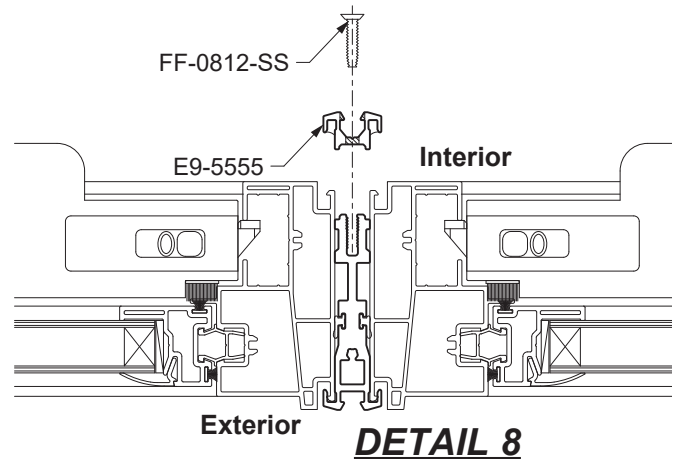

STEP 6 APPLY SEALANT AND SIKA TAPE

-At the ends of the mullions, fill the gap between them with sealant, and apply sika tape over the gap as shown in **Detail 9**.

STEP 7 INSTALL THE VINYL SNAP COVERS

-Cut the PE5-7084 snap covers to the window frame height.
-Snap them into both the exterior and interior of the factory mullion. See **Detail 9**.

